

SINAMICS S120/SIMODRIVE 611/
SIMOVERT MASTERDRIVES MC
SIMAG H2 Hollow-Shaft Measuring System

SIEMENS

SIEMENS

SINAMICS S120, SIMODRIVE, SIMOVERT MASTERDRIVES

SIMAG H2 Hollow-Shaft Measuring System

Configuration Manual

Foreword

Description of the Encoder

1

Mounting

2

Dimension Drawings

3

Appendix

A

Safety Guidelines

This manual contains notices you have to observe in order to ensure your personal safety, as well as to prevent damage to property. The notices referring to your personal safety are highlighted in the manual by a safety alert symbol, notices referring only to property damage have no safety alert symbol. These notices shown below are graded according to the degree of danger.



Danger

indicates that death or severe personal injury **will** result if proper precautions are not taken.



Warning

indicates that death or severe personal injury **may** result if proper precautions are not taken.



Caution

with a safety alert symbol, indicates that minor personal injury can result if proper precautions are not taken.

Caution

without a safety alert symbol, indicates that property damage can result if proper precautions are not taken.

Notice

indicates that an unintended result or situation can occur if the corresponding information is not taken into account.

If more than one degree of danger is present, the warning notice representing the highest degree of danger will be used. A notice warning of injury to persons with a safety alert symbol may also include a warning relating to property damage.

Qualified Personnel

The device/system may only be set up and used in conjunction with this documentation. Commissioning and operation of a device/system may only be performed by **qualified personnel**. Within the context of the safety notes in this documentation qualified persons are defined as persons who are authorized to commission, ground and label devices, systems and circuits in accordance with established safety practices and standards.

Prescribed Usage

Note the following:



Warning

This device may only be used for the applications described in the catalog or the technical description and only in connection with devices or components from other manufacturers which have been approved or recommended by Siemens. Correct, reliable operation of the product requires proper transport, storage, positioning and assembly as well as careful operation and maintenance.

Trademarks

All names identified by ® are registered trademarks of the Siemens AG. The remaining trademarks in this publication may be trademarks whose use by third parties for their own purposes could violate the rights of the owner.

Disclaimer of Liability

We have reviewed the contents of this publication to ensure consistency with the hardware and software described. Since variance cannot be precluded entirely, we cannot guarantee full consistency. However, the information in this publication is reviewed regularly and any necessary corrections are included in subsequent editions.

Foreword

Information on the documentation

This document is part of the Technical Customer Documentation which has been developed for the SIMODRIVE, SIMOVERT MASTERDRIVES MC and SINAMICS S120 drive converter systems. All of the documents are available individually. The documentation list, which includes all Advertising Brochures, Catalogs, Overviews, Short Descriptions, Operating Instructions and Technical Descriptions with Order No., ordering address and price can be obtained from your local Siemens office.

This document does not purport to cover all details or variations in equipment, nor to provide for every possible contingency to be met in connection with installation, operation or maintenance.

We would also like to point-out that the contents of this document are neither part of nor modify any prior or existing agreement, commitment or contractual relationship. The sales contract contains the entire obligations of Siemens. The warranty contained in the contract between the parties is the sole warranty of Siemens. Any statements contained herein neither create new warranties nor modify the existing warranty.

Technical Support

If you have any questions, please contact the following Hotline:

Tel.: +49 (0) 180 5050–222
Fax: +49 (0) 180 5050–223
Internet: <http://www.siemens.com/automation/support-request>

Please send any questions about the documentation (e.g. suggestions for improvement, corrections) to the following fax number or email address:

Fax: +49 (0) 9131 98–63315
Fax form: Refer to the correction sheet at the end of the document
E-mail: motioncontrol@siemens.com

Information on Products

Up-to-date information about our products is available on the Internet at:

<http://www.siemens.com/motioncontrol>

You can find information on SINAMICS at:

<http://www.siemens.com/sinamics>

Danger and warning information



Danger

Commissioning shall not start until it has been absolutely ensured that the machine in which the components described here are to be installed complies with Directive 98/37/EC.

Only suitable qualified personnel may commission this device and the synchronous motors.

This personnel must carefully observe the technical customer documentation associated with this product and be knowledgeable about and carefully observe the danger and warning information.

Operational electrical equipment and motors have parts and components which are at hazardous voltage levels.

Dangerous mechanical movement may occur in the system during operation.

All work on the electrical system may only be carried-out when the system has been disconnected from the power supply and locked-out so that it cannot be accidentally restarted.



Warning

The successful and safe operation of this equipment and motors depends on correct transport, proper storage and installation, as well as careful operation and maintenance.

The specifications in the Catalogs and quotations also apply to special variants of the devices and motors.

In addition to the danger and warning information/instructions in the technical customer documentation supplied, the applicable domestic, local and plant-specific regulations and requirements must be carefully taken into account.



Caution

For synchronous motors, voltages are present at the motor terminals when the rotor is rotating (as a result of the permanent magnets).

The motors can have surface temperatures of over +100° C.

For this reason, temperature-sensitive parts (cables or electronic components, for example) may not be placed on or attached to the motor.

When connecting-up cables, please observe that they

- are not damaged
 - are not subject to tensile stress
 - cannot be touched by rotating components.
-

ESDS instructions



Caution

ElectroStatic-Sensitive Devices (ESDS) are individual components, integrated circuits, or modules that can be damaged by electrostatic fields or discharges.

ESDS regulations for handling boards and equipment:

When handling components that can be destroyed by electrostatic discharge, it must be ensured that personnel, the workstation and packaging are well grounded!

Personnel in ESD zones with conductive floors may only touch electronic components if they are

- grounded through an ESDS bracelet and
- wearing ESDS shoes or ESDS shoe grounding strips.

Electronic boards may only be touched when absolutely necessary.

Electronic boards may not be brought into contact with plastics and articles of clothing manufactured from man-made fibers.

Electronic boards may only be placed on conductive surfaces (table with ESDS surface, conductive ESDS foam rubber, ESDS packing bag, ESDS transport containers).

Electronic boards may not be brought close to data terminals, monitors or television sets. Minimum clearance to screens > 10 cm).

Measurements may only be carried-out on electronic boards and modules if

- the measuring instrument is grounded (e.g. via a protective conductor) or
 - before making measurements with a potential-free measuring device, the measuring head is briefly discharged (e.g. by touching an unpainted blank piece of metal on the control cabinet).
-

Standards, regulations

The appropriate standards, regulations are directly assigned to the functional requirements.

Table of contents

	Foreword	iii
1	Description of the Encoder	1-1
1.1	Features	1-1
1.2	Technical data	1-3
1.3	Sensor head	1-6
1.4	Measuring wheel	1-7
1.5	Connecting kit	1-7
1.6	Disassembly tool (optional)	1-8
2	Mounting	2-1
2.1	General	2-1
2.2	Mounting the measuring wheel	2-2
2.3	Mounting/adjusting the sensor head	2-4
2.4	Mounting, connecting kit	2-5
2.5	Adapter kit	2-6
3	Dimension Drawings	3-1
A	Appendix	A-1
A.1	References	A-1
	Index	Index-1

Description of the Encoder

1.1 Features

Field of application

SIMAG H2 is an incremental measuring system (encoder system) to sense rotational angles and rotational velocities.

SIMAG H2 is used for hollow-shaft applications with 1FE1 and 1PH2 direct drives, third-party spindles. It is also used as autonomous spindle encoder.

SIMAG H2 can be used with the following SIEMENS drive systems:

- SIMODRIVE 611 digital
- SIMODRIVE 611 analog (in this case, only in conjunction with a measuring wheel with a pole number of $2n$)
- SIMOVERT MASTERDRIVES
- SINAMICS S120

Design

The SIMAG H2 measuring system consists of the following components:

- Measuring wheel
- Sensor head with connecting cable 1x and feeler gauge (0.20 mm)
- Connecting kit comprising a flange-mounted socket, straight or angled
- Adapter kit (optional)
Using this adapter kit, the mechanical system of the SIMAG H2 can be adapted to other measuring systems without having to modify the mechanical system of the particular machine.
Adapter kits are available for the following measuring systems:
 - SIZAG 2
 - SIMAG H

1.1 Features

The magnetic division on the measuring wheel is used as unit of measurement. Different internal diameters are available for each outer diameter. The internal diameter can be re-worked.

The measuring wheel is retained using a shaft nut. Alternatively, it is possible to screw it against a shaft shoulder (this isn't possible for all measuring wheel versions) or the measuring wheel can also be shrunk on.

The non-contact sensor head scans the incremental and reference tracks on the measuring wheel and amplifies the signals.

The encoder is connected to the flange-mounted socket using standard motor signal cables (refer to Chapter "Dimension Drawings").

Notice

SIMAG H2 is piece of measuring equipment.

Only appropriately qualified personnel may mount this encoder system.

Any type of damage will have a severe negative impact on the function and/or make the system unusable. We will not assume any responsibility for damage that is caused by incorrect handling.

Only remove the encoder components from their packaging where they are to be actually installed!

The ESDS handling rules must be carefully maintained (refer to Foreword).

All of the work must be carried-out with the system in a no-voltage condition.

It should be ensured that suitable HF grounding is provided.

In order to secure a high degree of noise immunity, the sensor head and the flange-mounted socket must be conductively mounted onto a grounded metal body or assembly.

Output signals

The mounted and adjusted measuring system supplies the following signals:

- Two sinusoidal incremental signals with 1 Vpp shifted through 90°
- A squarewave reference signal for each revolution

Connecting

Pre-fabricated signal cables are available to connect the measuring system to SIMODRIVE, SIMOVERT MASTERDRIVES and SINAMICS drive converters.

For the order designation, refer to Catalog, Chapter Connection systems.

1.2 Technical data

Table 1-1 Technical data, SIMAG H2 Hollow-Shaft Measuring System

Property	Description/Technical data
SIMAG H2 Hollow-Shaft Measuring System	
Pitch precision of the measuring wheel, 1 mm pole pitch	±96" for pole number = 192 ±72" for pole number = 256 ±46" for pole number = 400 ±38" for pole number = 480 ±23" for pole number = 800
Storage temperature	-20 °C...+70 °C (packed)
Operating temperature	-20 °C...+120 °C
Degree of protection per DIN EN 60529 (IEC 60529)	IP67 (when installed)
Permissible bending radius	Connecting cable for the cable assembly: Bending radius > 25 mm once Bending radius > 60 mm, several times
Permissible cable length	Max. 50 m depending on the closed-loop control used (for the cables that can be used refer to the Connection Systems section of the Catalog)
Vibration (50 to 2000 Hz)	Max. 200 m/s ²
Shock (11 ms)	Max. 1000 m/s ²
Axial assignment measuring wheel – sampling head	Nominal size 3 mm (refer to "Mounting drawing, SIMAG H2" figure). Permissible axial tolerance: ±1 mm relative to the nominal size. The permissible axial tolerance must be adhered to under all operating conditions (temperature, vibration, etc.).
Radial assignment measuring wheel – sampling head	Pole pitch 1 mm: Nominal size can be adjusted using a feeler gauge: 0.2 mm (refer to "Mounting drawing, SIMAG H2" figure). Permissible radial tolerance: +0.1 mm relative to the nominal size The permissible radial tolerance must be adhered to under all operating conditions (temperature, vibration etc.).
Maximum permissible speed	6FX2001-6RB12-3□□□: 33000 RPM 6FX2001-6RB12-4□□□: 25000 RPM 6FX2001-6RB12-5□□□: 16000 RPM 6FX2001-6RB12-6□□□: 13000 RPM 6FX2001-6RB12-7□□□: 8000 RPM
Power supply	5 VDC ± 5%
Current consumption (typical)	30 mA
Output signals	Sinusoidal 1 V _{pp} if signal cable is terminated with 120 Ω
Other	The measuring system components are resistant to commercially available coolants and lubricants.

Description of the Encoder

1.2 Technical data

Property	Description/Technical data		
Measuring wheel, Da 60.72 mm			
Inner diameter ¹⁾		40 ^{H6} mm	
Outer diameter D1		60.72 mm	
Thickness		15 mm	
Pulse number per revolution		192	
Moment of inertia, approx.		1.0 x 10 ⁻⁴ kgm ²	
Approx. weight		0.20 kg	
Measuring wheel, Da 81.14 mm			
Inner diameter ¹⁾	45 ^{H6} mm	60 ^{H6} mm	65 ^{H6} mm
Outer diameter D1	81.14 mm	81.14 mm	81.14 mm
Thickness	15 mm	15 mm	15 mm
Pulse number per revolution	256	256	256
Moment of inertia, approx.	3.8 x 10 ⁻⁴ kgm ²	2.8 x 10 ⁻⁴ kgm ²	2.2 x 10 ⁻⁴ kgm ²
Approx. weight	0.35 kg	0.25 kg	0.20 kg
Measuring wheel, Da 126.92 mm			
Inner diameter ¹⁾	65 ^{H6} mm	85 ^{H6} mm	100 ^{H6} mm
Outer diameter D1	126.92 mm	126.92 mm	126.92 mm
Thickness	15 mm	15 mm	15 mm
Pulse number per revolution	400	400	400
Moment of inertia, approx.	25 x 10 ⁻⁴ kgm ²	21 x 10 ⁻⁴ kgm ²	16 x 10 ⁻⁴ kgm ²
Approx. weight	1.0 kg	0.75 kg	0.5 kg
Measuring wheel, Da 152.39 mm			
Inner diameter ¹⁾	80 ^{H6} mm	110 ^{H6} mm	
Outer diameter D1	152.39 mm	152.39 mm	
Thickness	15 mm	15 mm	
Pulse number per revolution	480	480	
Moment of inertia, approx.	54 x 10 ⁻⁴ kgm ²	42 x 10 ⁻⁴ kgm ²	
Approx. weight	1.5 kg	1.0 kg	
Measuring wheel, Da 254.25 mm			
Inner diameter ¹⁾	150 ^{H6} mm		
Outer diameter D1	254.25 mm		
Thickness	15 mm		
Pulse number per revolution	800		
Moment of inertia, approx.	420 x 10 ⁻⁴ kgm ²		
Approx. weight	3.9 kg		
Sampling head with cable			
Housing material	Aluminum		
Signal cable outlet	45°		

- 1) The measuring wheels can be post-machined (by increasing the inner diameter or by drilling holes/tapping threads); refer to "Mounting types" table

Error due to eccentricity, see next page.

Error due to eccentricity

Additional error when mounted:

$$\pm |\Delta\varphi| [^\circ] = \frac{1296 \cdot \text{Eccentricity}^2 [\mu\text{m}]}{\text{Pole number} \cdot \text{Pole pitch} [\text{mm}]}$$

²⁾ Max. permissible eccentricity at room temperature: 20 μm

Output signals

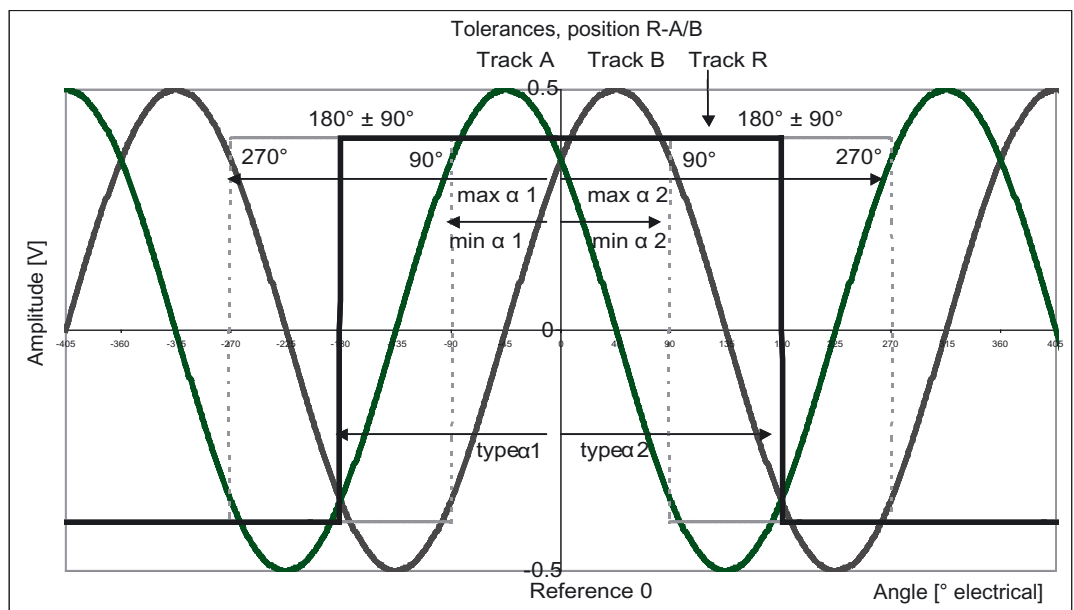

Figure 1-1 Encoder signals for a clockwise direction or rotation

1.3 Sensor head

Table 1-2 Signal tolerances (at the measuring system outputs with a 120 Ω termination)

Parameters	Name	Comments	Min.	Typ.	Max.	Units
Signal size	A-*A; B-*B	V _B = 5 V f ≤ 20 kHz	0.75	1	1.20	V _{pp}
Ratio	(A-*A)/(B-*B)		0.9	1.0	1.1	-
DC component (offset)	V _{off} (A-*A); V _{off} (B-*B)		-15	0	+15	mV
Phase shift between track A and track B	β		89	90	91	Degrees
Wanted signal	R-R*		0.4	-	1.2	V
DC component (offset)	V _{off} (R-R*)		-300	-450	-600	mV
Clear signal range R signal	α1; α2		90	180	270	Degrees

1.3 Sensor head

- Compact sensor head for mounting on the bearing endshield of a motor or a spindle
- It is adjusted using a feeler gauge

Table 1-3 Order No., sensor head

Order No.	Version
6FX2001-6AA12-1CA0	Sensor head with 0.2 m cable, pre-fabricated
6FX2001-6AA12-1FA0	Sensor head with 0.5 m cable, pre-fabricated
6FX2001-6AA12-3AA0	Sensor head with 2.0 m cable, pre-fabricated
6FX2001-6AA12-2AA5	Sensor head with 1.0 m cable, open conductor ends

1.4 Measuring wheel

- Magnetic material on a steel hub
- One track for each of the incremental signals as well as for the zero signal
- Pole pitch of the incremental track, 1 mm
- Number of poles (resolution) of the incremental track depending on the outer diameter
- Various inner diameters (refer to the table)
- Mounting types (refer to Chapter "Mounting the measuring wheel")
- The inner diameter can be machined, e.g. by turning on a lathe
- It is not possible to machine the outer diameter D1.

Table 1-4 Measuring wheel versions (for an assignment of the dimensions, refer to Chapter "Dimension Drawings")

Order No. Measuring wheel 6FX2001-6RB12-	Pole number	Outer diameter D1 [mm]	Inner diameter	
			D2 [mm]	D2 max. [mm]
3EA0	192	60.72	40	45
4EF0	256	81.14	45	65
4GA0	256	81.14	60	65
4GF0	256	81.14	65	65
5GF0	400	126.92	65	100
5JF0	400	126.92	85	100
5LA0	400	126.92	100	100
6JA0	480	152.39	80	126
6MA0	480	152.39	110	126
7SA0	800	254.25	150	220

1.5 Connecting kit

Flange-mounted sockets in the following versions are available as connecting kit:

Table 1-5 Order No., connecting kit

Order No.	Version
6FX2001-6FA12-0GA0	Straight
6FX2001-6FA12-0WA0	Angled

1.6 Disassembly tool (optional)

A special tool is required to remove the insulating insert from the flange-mounted socket.
Order Nos.: 6FX2001-6FK12-0AA0

Mounting

2.1 General

Mounting overview

The encoder system is mounted in three steps:

- The measuring wheel is mounted onto the spindle shaft (refer to Chapter "Mounting the measuring wheel")
- The sensor head is mounted/adjusted (refer to Chapter "Mounting/adjusting, sensor head")
- Mounting the connecting kit (refer to Chapter "Connecting kit")

Dimension data and tolerances

All of the dimension data, tolerances and designations in this Chapter refer to the dimension drawings (refer to Chapter "Dimension Drawings").

Notice

SIMAG H2 is piece of measuring equipment.

Only appropriately qualified personnel may mount this encoder system.

Any type of damage will have a severe negative impact on the function and/or make the system unusable.

Only remove the encoder components from their packaging where they are to be actually installed! The ESDS handling rules must be carefully maintained (refer to Foreword).

All of the work must be carried-out with the system in a no-voltage condition.

We will not assume any responsibility for damage that is caused by incorrect handling.

Mounting space of the measuring system

Caution

The space/area in which the measuring system is mounted must be free of chips and dust.

It must be guaranteed that no foreign objects can attach themselves to the area between the measuring wheel and sensor head. Otherwise, there is a danger that the measuring wheel and/or sensor head could be damaged.

If necessary, appropriately cover the measuring system.

External fields

Current flowing through motor windings and power cables generates magnetic fields.

In order to avoid negative effects on the measuring accuracy of the encoder system, a minimum clearance of 10 mm should be maintained between the motor windings/power cables and sensor head at all sides.

2.2 Mounting the measuring wheel

Notice

Permanent magnets, magnetic holders for dial gauges etc. must be kept away from the measuring wheel; only use non-magnetic tools!

Note

The eccentricity of the mounted measuring wheel influences the accuracy of of the total system (refer to Chapter "Technical data").

Tolerances, motor shaft

Permissible running tolerances as well as position tolerances of the holes, refer to Fig. "Dimension drawing, bearing endshield and shaft (SIMAG H2)".

Mounting types

The measuring wheel can be attached to the shaft in the following ways:

1. Shrink fit
2. Axially screwed
3. Axially clamped

Table 2-1 Mounting types; designation of the diameter, refer to Fig. "Overview tables, SIMAG H2"

Application	Diameters D2, D2max, D5	Information
Shrink fit (retaining type)	D2/D5 Press fit, e.g. H6/r6 or H6/s6	<ul style="list-style-type: none"> • Inductive heating is not permissible • Max. measuring wheel temperature 150° C
Screws (retaining type)	D2max Removing material beyond D2max is not permissible	<ul style="list-style-type: none"> • Mounting holes/removal threads should be provided on the customer side • Screws and washers are not included in the scope of supply • Carefully note the tightening torque (refer to Table SIMAG H2 rotary-encoder system)
Shaft nut (retaining type)	—	<ul style="list-style-type: none"> • The shaft nut is not included in the scope of supply • Tightening torque: MD = f(F_{clamp}), F_{clamp} = 20 kN according to the manufacturers data
Increasing D2 on a lathe	Customer-specific diameter It is not permissible to remove material beyond D2max	<ul style="list-style-type: none"> • Mounting over D3 with clamping clip • Maintain radial eccentricity 0.02 mm from D1 to D2
Play	D2/D5 Max. permissible play: 0.02 mm	—

2.3 Mounting/adjusting the sensor head

Notice

SIMAG H2 is piece of measuring equipment.

The sensor head must be screwed to a grounded metal body or assembly through a good electrical connection

The sensor head is adjusted using the feeler gauge provided.

It is not permissible to adjust the sensor head using the encoder signals.

Before and during installation/mounting, all of the parts and mounting surfaces must be free of any dirt.

The tightening torques must be carefully maintained (refer to the Table in Fig. "SIMAG H2 rotary encoder system").

Mounting and installation steps

The mounting location must be free of any accumulated dirt.

Numbers in brackets, refer to Fig. "SIMAG H2 rotary encoder system".

1. Mount the measuring wheel (1) to the shaft either using screws, shaft nuts or by shrinking it to the shaft collar (refer to Table "Mounting types").
2. Screw the sensor head (2) with two screws M4 (4), washers DIN 125 (3) to the bearing endshield, slightly tighten the screws.
The metal piece on the sensor head must face toward the measuring wheel.
3. Adjust the air gap using the feeler gauge supplied (7). A minimum air gap must be maintained (refer to Fig. "Mounting drawing, SIMAG H2"). Position the sensor head with slight pressure against the feeler gauge and measuring wheel; tighten the screws (4) and secure so that they cannot become loose.
4. Remove the feeler gauge.
5. When mounting the rotary encoder in spindles/motors, the insulating body of the cable should be guided through the mounting hole for the flange-mounted socket (5).
6. Mounting/disassembling the flange-mounted socket (5) is described in the associated mounting instructions of the connecting kit (refer to Chapter "Connecting kit").

2.4 Mounting, connecting kit

Notice

The flange-mounted socket must be screwed to a grounded metal body/assembly with a good electrical connection. Remove any paint from the mounting surface.

In order to guarantee disturbance-free operation, the pre-assembled conductor ends may not be disassembled.

Dimensions of the flange-mounted socket and mounting holes, refer to Chapter "Dimension Drawings".

EMC Directive

Notice

The general Directives for EMC correct cable routing must be carefully observed.

Mounting and installation steps

Prerequisite: The measuring wheel and sensor head have been mounted.

1. Insert the insulating insert into the flange-mounted socket. Make sure that it reliably engages.
2. Insert the flange-mounted socket in the mounting hole and retain using the four M2.5 screws supplied (for the tightening torques, refer to the Table in Fig. "SIMAG H2 rotary encoder system").
3. Route the temperature sensor cable to the motor temperature sensor terminals; if required, shorten the cable and connect to the motor temperature sensor.
4. **When connecting-up the temperature sensor cable, carefully observe the polarity!** Refer to the product documentation of the motor manufacturer.
Conductor color and polarity of the cable: Refer to the connection assignment, connecting socket, Chapter "Technical data".

Note

A special tool is required to remove the insulating insert (refer to Chapter "Disassembly tool" (optional)).

Cable installation

When routing the signal and temperature encoder cables the following should be carefully observed:

- Cables should be routed so that they are not strained in any way
- They should not be routed over sharp edges
- They should be kept away from rotating parts
- They should be firmly retained (cable ties)
- Do not exceed the permissible bending radii (refer to Chapter "Technical data").

2.5 Adapter kit

The adapter kit allows the SIMAG H2 to be mounted in existing mounting assemblies of other measuring systems. Adapter kits are available for SIMAG H and SIZAG 2.

Table 2-2 Order No., adapter kit for SIMAG H

Components	Order No.
Adapter plate	6FX2001-6AK12-0HA0
Adapter ring 45 mm	6FX2001-6RK12-4EF0
Adapter ring 60 mm	6FX2001-6RK12-4GA0

Table 2-3 Order No., adapter kit for SIZAG 2

Components	Order No.
Adapter plate	6FX2001-6AK12-0SA0

Dimension Drawings

System rotary encoder SIMAG H2

Table 1
Item 6/7 not drawn

Item	Designation	Quantity	MLFB/Standard	Tightening torque	Delivery
1	Sensor wheel	1	Versions	---	Yes
2	Sensor head	1	Versions	---	Yes
3	Washer	2	DIN 125-A4.3-140HV-St	---	No
4	Screw	2	DIN free, M4x25 (Lmin)	1,8 Nm	No
5	Flange-mounted socket	1	Versions	---	Yes
6	Screw	4	M2.5x8 (thread grooving)	0,4 Nm	Yes
7	Feeler gauge	1	0.2 mm thick	---	Yes

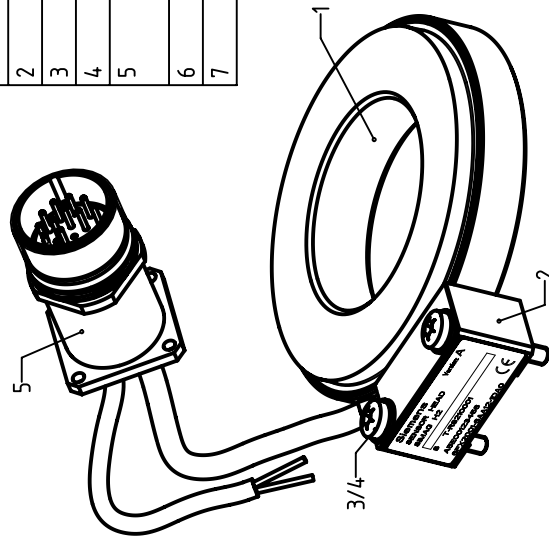

Figure 3-1 SIMAG H2 rotary encoder system

A5E00258237 ac
Sheet 1+

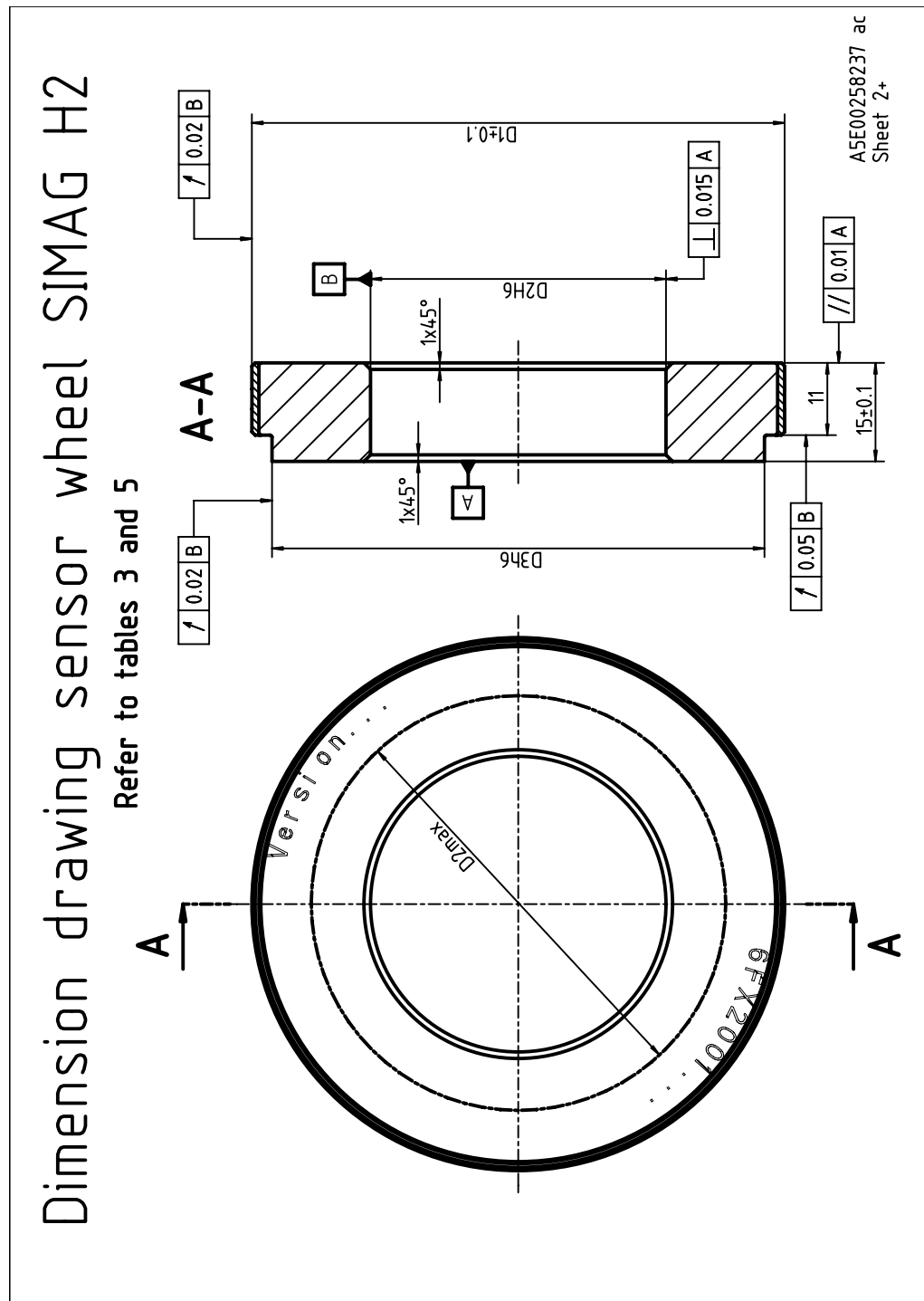

Figure 3-2 SIMAG H2 dimension drawing, measuring wheel

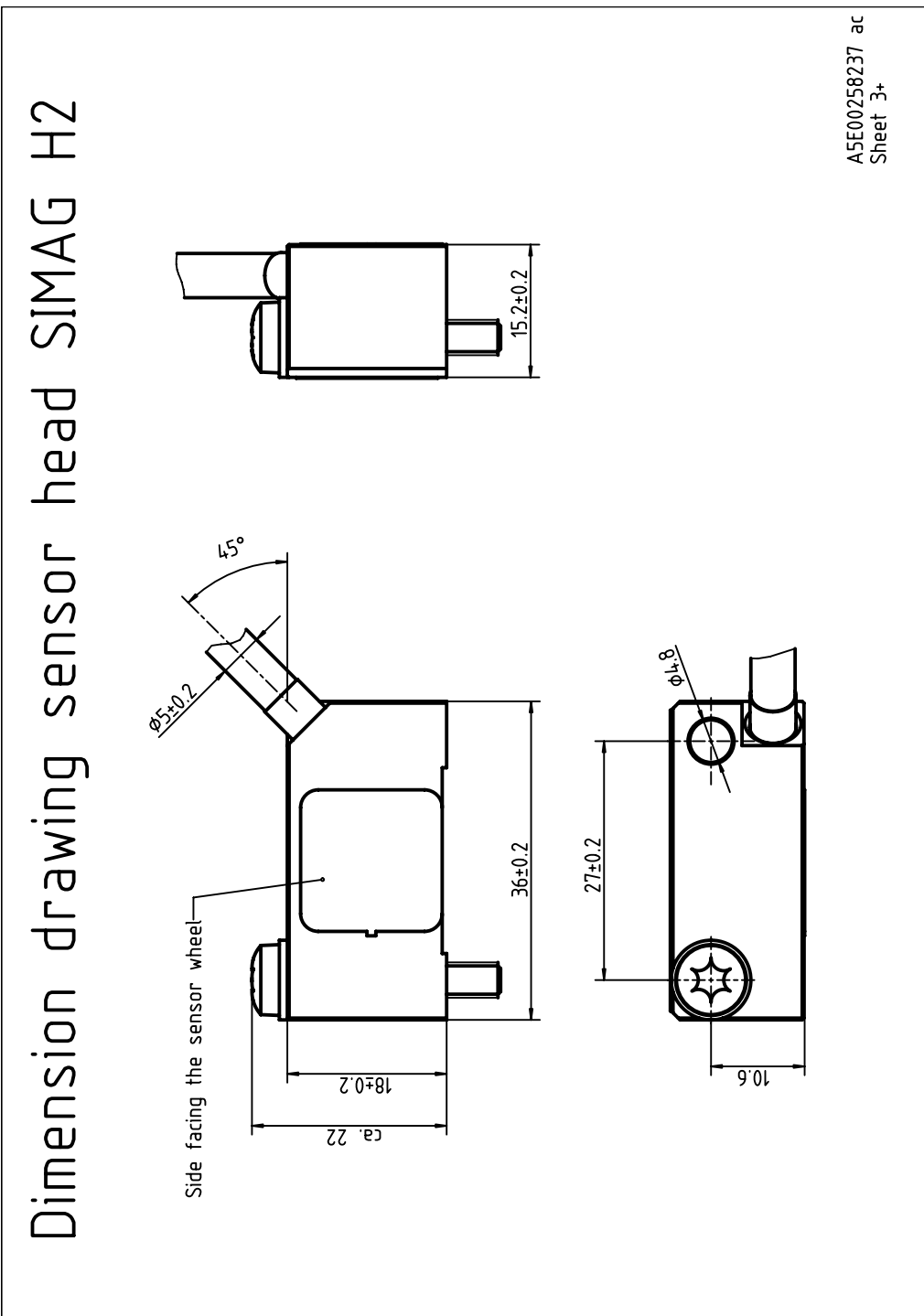

Figure 3-3 SIMAG H2 dimension drawing, sensor head

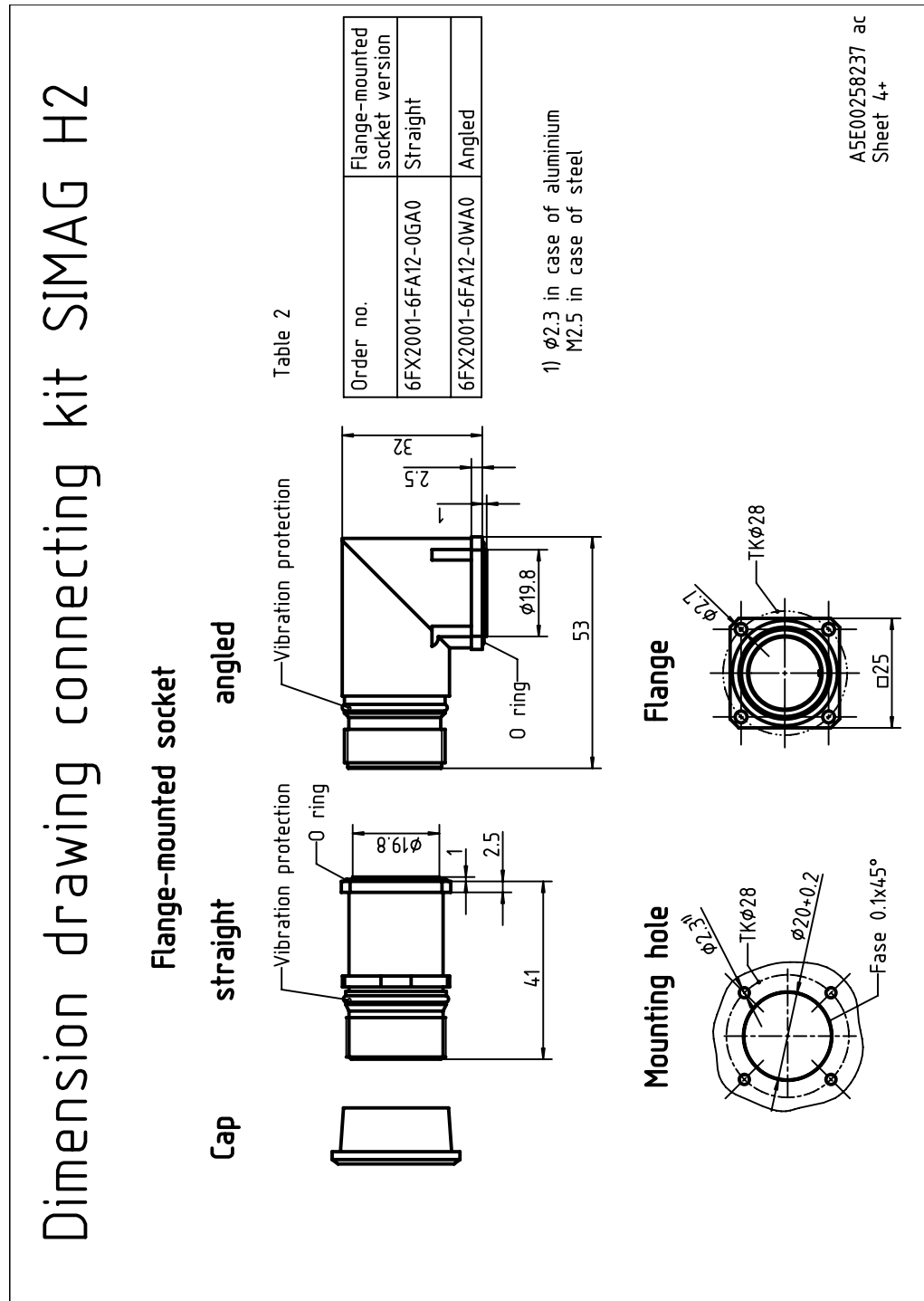

Figure 3-4 SIMAG H2 dimension drawing, connecting kit

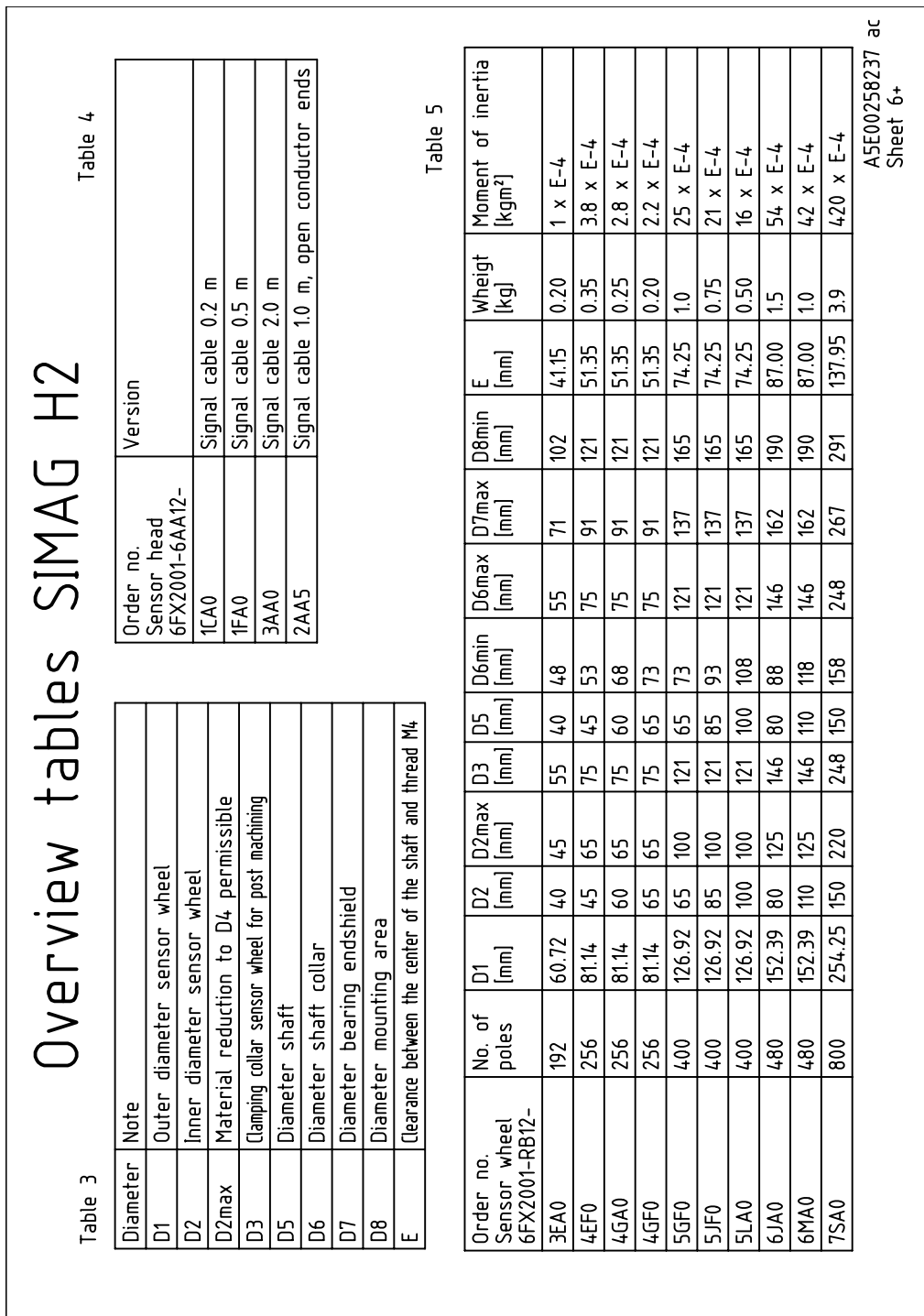
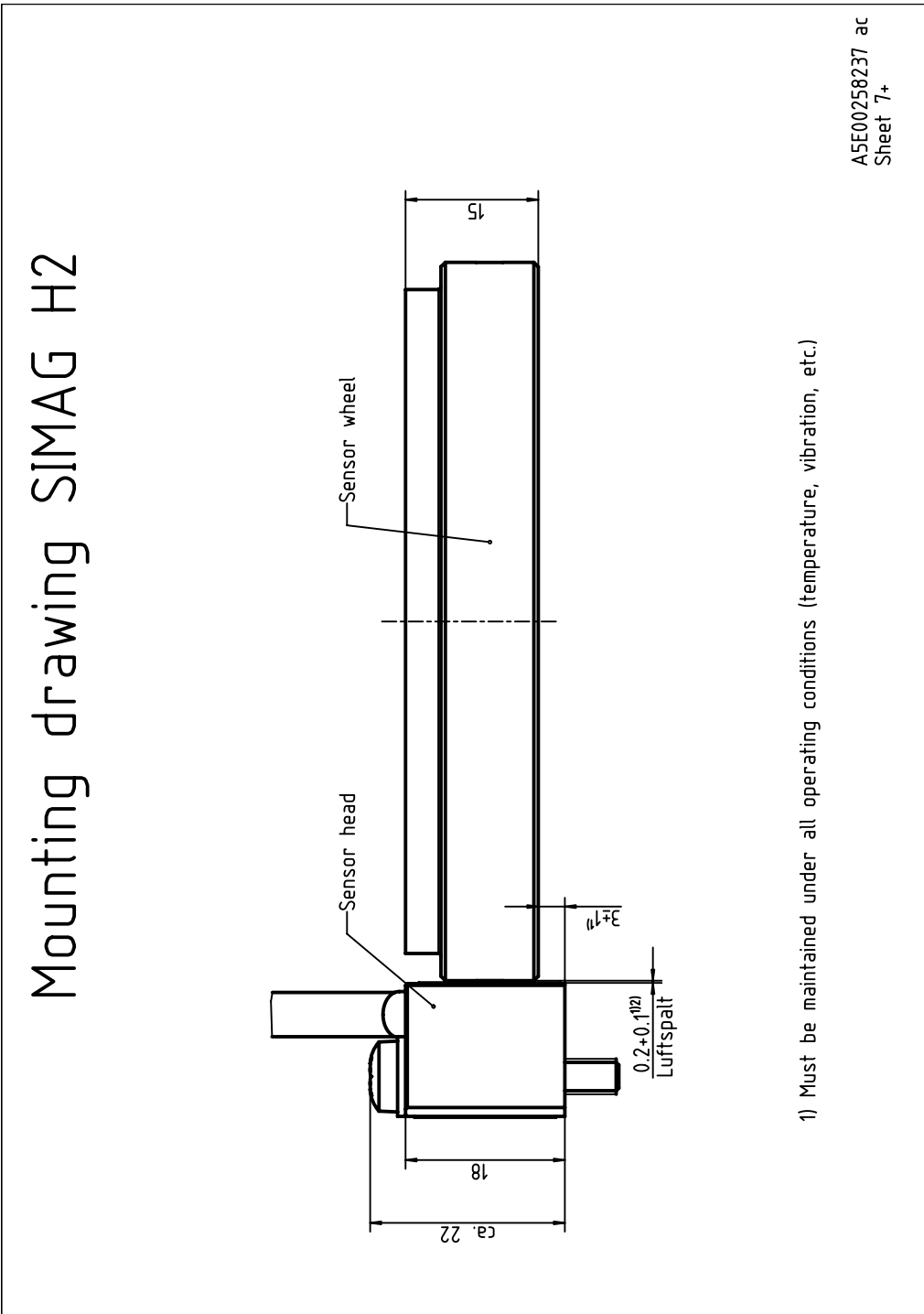

Figure 3-6 Overview tables, SIMAG H2



A5E00258237 ac
Sheet 7+

Figure 3-7 Mounting drawing, SIMAG H2

Assignment diagram SIMAG H2 (standard/special version)

10-conductor signal cable
AWG 28

Table 6

Signal name	Socket pin 17 pole	Conductor color
A+ (A)	1	yellow
A- (A*)	2	green
B+ (B)	11	brown
B- (B*)	12	white
R+ (R)	3	grey
R- (R*)	13	pink
P encoder	10	red
M encoder	7	blue
P sense	16	--
M sense	15	--

Pin 7 connected to pin 15 in the socket
Pin 10 connected to pin 16 in the socket

The black and purple conductors (cut)
remain free and are not assigned

2/8-conductor temperature cable
AWG 24

Table 7

Signal name	Pin Socket	Conductor color	2 conductor	8 conductor
KTY 84+	8	brown	Yes	Yes
KTY 84-	9	white	Yes	Yes
PTC	4	blue	No	Yes
PTC	14	red	No	Yes
NTC K227	4	green	No	Yes
NTC K227	5	yellow	No	Yes
NTC PT3-51F	5	pink	No	Yes
NTC PT3-51F	6	grey	No	Yes

Diagram of the pins:
View on the connector side

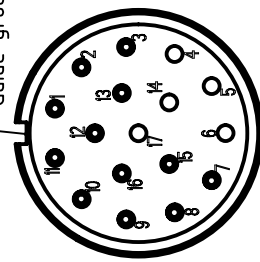

A5E00258237 ac
Sheet 8-

Figure 3-8 Assignment diagram, SIMAG H2

Appendix

A.1 References

An overview of publications that is updated monthly is provided in a number of languages in the Internet at:

<<http://www.siemens.com/motioncontrol>>
through "Support", "Technical Documentation", "Documentation Overview"

General Documentation

/D 21.2/	SINAMICS S120 Catalog SINAMICS S120 Servo Control Drive System
/NC 60/	SINUMERIK and SIMODRIVE Catalog Automation Systems for Machine Tools
/DA65.3/	SIMOVERT MASTERDRIVES Catalog Synchronous and Induction Motors for SIMOVERT MASTERDRIVES

Electronic Documentation

/CD1/	DOC ON CD The SINUMERIK System (includes all SINUMERIK 840D/810D and SIMODRIVE 611D)
/CD2/	DOC ON CD The SINAMICS System

Manufacturer/Service Documentation

/PJAL/	Configuration Manual, Synchronous Motors SINAMICS S120, SIMODRIVE 611, SIMOVERT MASTERDRIVES Synchronous Motors General Section
/PFK7S/	Configuration Manual, Synchronous Motors SINAMICS S120 1FK7 Synchronous Motors
/PFT6S/	Configuration Manual, Synchronous Motors SINAMICS S120 1FT6 Synchronous Motors
/APH7S/	Configuration Manual, Induction Motors SINAMICS S120 Servo Control/Vector Control Induction Motors 1PH7
/PMH2/	Configuration Manual, Hollow-Shaft Measuring System SINAMICS S120, SIMODRIVE 611, SIMOVERT MASTERDRIVES, SIMAG H2 Hollow-Shaft Measuring System
/PJM2/	Configuration Manual, Synchronous Motors SIMODRIVE 611, SIMOVERT MASTERDRIVES Synchronous Motors General Section, 1FT5, 1FT6, 1FK6, 1FK7
/PFK7/	Configuration Manual, Synchronous Motors SIMODRIVE 611, SIMOVERT MASTERDRIVES 1FK7 Synchronous Motors
/PFT6/	Configuration Manual, Synchronous Motors SIMODRIVE 611, SIMOVERT MASTERDRIVES 1FT6 Synchronous Motors

/PFK6/	Configuration Manual, Synchronous Motors SIMODRIVE 611, SIMOVERT MASTERDRIVES 1FK6 Synchronous Motors
/PFS6/	Configuration Manual, Synchronous Motors SIMOVERT MASTERDRIVES 1FS6 Synchronous Motors, Explosion-Protected
/PFU/	Configuration Manual, Synchronous Motors SINAMICS S120, SIMOVERT MASTERDRIVES, MICROMASTER SIEMOSYN Synchronous Motors 1FU8
/ASAL/	Configuration Manual, Induction Motors SIMODRIVE 611, SIMOVERT MASTERDRIVES Induction Motors General Section
/APH2/	Configuration Manual, Induction Motors SIMODRIVE 611 1PH2 Induction Motors
/APH4/	Configuration Manual, Induction Motors SIMODRIVE 611 1PH4 Induction Motors
/APH7/	Configuration Manual, Induction Motors SIMODRIVE 611 1PH7 Induction Motors
/PPM/	Configuration Manual, Hollow-Shaft Motors SIMODRIVE 611 Hollow Shaft Motors for Main Spindle Drives 1PM6 and 1PM4

/PJFE/	Configuration Manual, Synchronous Build-in Motors SIMODRIVE 611 Synchronous Motors for Main Spindle Drives 1FE1 Synchronous Build-in Motors
/PJTM/	Configuration Manual, Build-in Torque Motors SIMODRIVE 611 Build-in Torque Motors 1FW6
/PJLM/	Configuration Manual, Linear Motors SIMODRIVE 611 Linear Motors 1FN1 and 1FN3
/PMS/	Configuration Manual, ECO Motor Spindle SIMODRIVE 611 ECO Motor Spindle 2SP1
/APL6/	Configuration Manual, Induction Motors SIMOVERT MASTERDRIVES Induction Motors 1PL6
/APH7M/	Configuration Manual, Induction Motors SIMOVERT MASTERDRIVES VC/MC Induction Motors 1PH7
/PKTM/	Configuration Manual, Complete Torque Motors SIMOVERT MASTERDRIVES Complete Torque Motors 1FW3

Index

A

Adjusting the sensor head, 2-4

D

Danger and warning information, v
Design, 1-1
Dimension drawings, 3-1

E

Encoder signals, 1-5
ESDS instructions, vi

F

Field of application, 1-1

H

Hotline, iv

I

Installation
 Connecting kit, 2-5
 Measuring wheel, 2-3
 Sensor head, 2-4

O

Order No.
 Connecting kit, 1-7
 Sensor head, 1-6
Order Nos.
 Adapter kit, 2-6
 Measuring wheel, 1-7
 Special tool, 1-8
Output signals, 1-2, 1-5

S

Signal tolerances, 1-6

T

Technical data, 1-3

To
 SIEMENS AG
 A&D MC BMS
 Postfach 3180
 D-91050 Erlangen
 Tel.: +49 (0) 180 / 5050 - 222 (Service Support)
 Fax: +49 (0) 9131 / 98 – 63315 (Documentation)
 email: motioncontrol@siemens.com

From	
Name _____	
Company/Department _____	
Address _____	
Postal code: _____	Town: _____
Telephone: _____	/
Telefax: _____	/

Suggestions
Corrections
For Publication/Manual: SIMAG H2 Hollow-Shaft Measuring System
Manufacturer/Service Documentation
Configuration Manual
Order No.: 6SN1197-0AB31-0BP3
Edition: 09.2005
If you come across any printing errors in this document, please let us know using this form. We would also be grateful for any suggestions and recommendations for improvement.

Suggestions and/or corrections



Siemens AG
Automation & Drives
Motion Control Systems
Postfach 3180, D - 91050 Erlangen
Federal Republic of Germany

www.siemens.com/motioncontrol

© Siemens AG 2004-2005
Subject to change without prior notice
Order No.: 6SN1197-0AB31-0BP3

Printed in the Federal Republic of Germany