

**FANUC Series 30*i*-MODEL B**  
**FANUC Series 31*i*-MODEL B**  
**FANUC Series 32*i*-MODEL B**

**MAINTENANCE MANUAL**

- No part of this manual may be reproduced in any form.
- All specifications and designs are subject to change without notice.

The products in this manual are controlled based on Japan's "Foreign Exchange and Foreign Trade Law". The export of Series 30*i*-B, Series 31*i*-B5 from Japan is subject to an export license by the government of Japan. Other models in this manual may also be subject to export controls.

Further, re-export to another country may be subject to the license of the government of the country from where the product is re-exported. Furthermore, the product may also be controlled by re-export regulations of the United States government.

Should you wish to export or re-export these products, please contact FANUC for advice.

The products in this manual are manufactured under strict quality control. However, when some serious accidents or losses are predicted due to a failure of the product, make adequate consideration for safety.

In this manual we have tried as much as possible to describe all the various matters.

However, we cannot describe all the matters which must not be done, or which cannot be done, because there are so many possibilities.

Therefore, matters which are not especially described as possible in this manual should be regarded as "impossible".

This manual contains the program names or device names of other companies, some of which are registered trademarks of respective owners. However, these names are not followed by ® or ™ in the main body.

# SAFETY PRECAUTIONS

This section describes the safety precautions related to the use of CNC units. It is essential that these precautions be observed by users to ensure the safe operation of machines equipped with a CNC unit (all descriptions in this section assume this configuration).

CNC maintenance involves various dangers. CNC maintenance must be undertaken only by a qualified technician.

Users must also observe the safety precautions related to the machine, as described in the relevant manual supplied by the machine tool builder.

Before checking the operation of the machine, take time to become familiar with the manuals provided by the machine tool builder and FANUC.

## Contents

DEFINITION OF WARNING, CAUTION, AND NOTE.....s-1  
 WARNINGS RELATED TO CHECK OPERATION .....s-2  
 WARNINGS RELATED TO REPLACEMENT .....s-3  
 WARNINGS RELATED TO PARAMETERS.....s-3  
 WARNINGS, CAUTIONS, AND NOTES RELATED TO DAILY MAINTENANCE.....s-4

## DEFINITION OF WARNING, CAUTION, AND NOTE

This manual includes safety precautions for protecting the maintenance personnel (herein referred to as the user) and preventing damage to the machine. Precautions are classified into Warnings and Cautions according to their bearing on safety. Also, supplementary information is described as a Note. Read the Warning, Caution, and Note thoroughly before attempting to use the machine.

**⚠ WARNING**  
 Applied when there is a danger of the user being injured or when there is a danger of both the user being injured and the equipment being damaged if the approved procedure is not observed.

**⚠ CAUTION**  
 Applied when there is a danger of the equipment being damaged, if the approved procedure is not observed.

**NOTE**  
 The Note is used to indicate supplementary information other than Warning and Caution.

\* Read this manual carefully, and store it in a safe place.

## WARNINGS RELATED TO CHECK OPERATION

### WARNING

- 1 When checking the operation of the machine with the cover removed
  - (1) The user's clothing could become caught in the spindle or other components, thus presenting a danger of injury. When checking the operation, stand away from the machine to ensure that your clothing does not become tangled in the spindle or other components.
  - (2) When checking the operation, perform idle operation without workpiece. When a workpiece is mounted in the machine, a malfunction could cause the workpiece to be dropped or destroy the tool tip, possibly scattering fragments throughout the area. This presents a serious danger of injury. Therefore, stand in a safe location when checking the operation.
- 2 When checking the machine operation with the power magnetics cabinet door opened
  - (1) The power magnetics cabinet has a high-voltage section (carrying a  mark). Never touch the high-voltage section. The high-voltage section presents a severe risk of electric shock. Before starting any check of the operation, confirm that the cover is mounted on the high-voltage section. When the high-voltage section itself must be checked, note that touching a terminal presents a severe danger of electric shock.
  - (2) Within the power magnetics cabinet, internal units present potentially injurious corners and projections. Be careful when working inside the power magnetics cabinet.
- 3 Never attempt to machine a workpiece without first checking the operation of the machine. Before starting a production run, ensure that the machine is operating correctly by performing a trial run using, for example, the single block, feedrate override, or machine lock function or by operating the machine with neither a tool nor workpiece mounted. Failure to confirm the correct operation of the machine may result in the machine behaving unexpectedly, possibly causing damage to the workpiece and/or machine itself, or injury to the user.
- 4 Before operating the machine, thoroughly check the entered data. Operating the machine with incorrectly specified data may result in the machine behaving unexpectedly, possibly causing damage to the workpiece and/or machine itself, or injury to the user.
- 5 Ensure that the specified feedrate is appropriate for the intended operation. Generally, for each machine, there is a maximum allowable feedrate. The appropriate feedrate varies with the intended operation. Refer to the manual provided with the machine to determine the maximum allowable feedrate. If a machine is run at other than the correct speed, it may behave unexpectedly, possibly causing damage to the workpiece and/or machine itself, or injury to the user.
- 6 When using a tool compensation function, thoroughly check the direction and amount of compensation. Operating the machine with incorrectly specified data may result in the machine behaving unexpectedly, possibly causing damage to the workpiece and/or machine itself, or injury to the user.



## WARNINGS RELATED TO REPLACEMENT

### WARNING

- 1 Before exchanging, be sure to shut off externally supplied power. Otherwise, electrical shocks, breakdown, and blowout may occur.  
If a control unit is turned off but other units are not, it is likely that power may be supplied to servo units, resulting in the units being damaged and workers getting an electrical shock when the units are exchanged.
- 2 In order to prevent damage that may be caused by static electricity, wear a grounding wrist strap or take a similar protective measure before starting to touch a printed-circuit board or unit or attach a cable.  
Static electricity from human bodies can damage electrical circuits.
- 3 Voltage lingers in servo and spindle amplifiers for a while even after power has been turned off, resulting in workers possibly getting an electrical shock when the workers touch them. Before starting to exchange these amplifiers, wait for 20 minutes after power has been turned off.
- 4 When replacing a unit, ensure that the new unit has the same parameters and settings as the old one. (For details, refer to the manual for the machine.)  
Otherwise, unpredictable machine movement could damage the workpiece or the machine itself or cause injury.
- 5 If you notice an apparent hardware fault, such as abnormal noise, abnormal odor, smoke, ignition, or abnormal heat, in the hardware while power is being supplied to it, shut it off at once. These faults can cause fire, breakdown, blowout, and malfunction.
- 6 The radiating fins of control units, servo amplifiers, spindle amplifiers, and other devices can remain very hot for a while after power has been turned off, making you get burned if you touch them. Before starting to work on them, wait and make sure they are cool.
- 7 When exchanging heavy stuff, you should do so together with two or more people.  
If the replacement is attempted by only one person, the old or new unit could slip and fall, possibly causing injury.
- 8 Be careful not to damage cables. Otherwise, electrical shocks can occur.
- 9 When working, wear suitable clothes with safety taken into account. Otherwise, injury and electrical shocks can occur.
- 10 Do not work with your hands wet. Otherwise, electrical shocks and damage to electrical circuits can occur.

## WARNINGS RELATED TO PARAMETERS

### WARNING

- 1 When machining a workpiece for the first time after modifying a parameter, close the machine cover. Never use the automatic operation function immediately after such a modification. Instead, confirm normal machine operation by using functions such as the single block function, feedrate override function, and machine lock function, or by operating the machine without mounting a tool and workpiece. If the machine is used before confirming that it operates normally, the machine may move unpredictably, possibly damaging the machine or workpiece, and presenting a risk of injury.

**⚠ WARNING**

- 2 The CNC and PMC parameters are set to their optimal values, so that those parameters usually need not be modified. When a parameter must be modified for some reason, ensure that you fully understand the function of that parameter before attempting to modify it. If a parameter is set incorrectly, the machine may move unpredictably, possibly damaging the machine or workpiece, and presenting a risk of injury.

**WARNINGS, CAUTIONS, AND NOTES RELATED TO DAILY MAINTENANCE****⚠ WARNING**

When using the controller unit, display unit, MDI unit, or machine operator's panel, prevent these units from directly exposing to chips or coolants. Even if direct exposure to coolants is prevented, coolants containing sulfur or chlorine at a high activation level, oil-free synthetic-type coolants, or water-soluble coolants at a high alkali level particularly have large effects on the control unit and peripheral units, possibly causing the following failures.

- Coolants containing sulfur or chlorine at a high activation level  
Some coolants containing sulfur or chlorine are at an extremely high activity level. If such a coolant adheres to the CNC or peripheral units, it reacts chemically with a material, such as resin, of equipment, possibly leading to corrosion or deterioration. If it gets in the CNC or peripheral units, it corrodes metals, such as copper and silver, used as component materials, possibly leading to a defective component.
- Synthetic-type coolants having a high permeability  
Some synthetic-type coolants whose lubricating component is, for example, PAG (polyalkylene glycol) have an extremely high permeability. If such a coolant is used even in equipment having a high closeness, it can readily flow into the CNC or peripheral units through, for example, gaskets. It is likely that, if the coolant gets in the CNC or a peripheral unit, it may deteriorate the insulation and damage the components.
- Water-soluble coolants at a high alkali level  
Some coolants whose pH is increased using alkanolamine are so strong alkali that its standard dilution will lead to pH10 or higher. If such a coolant spatters over the surface of the CNC or peripheral unit, it reacts chemically with a material, such as resin, possibly leading to corrosion or deterioration.

**⚠ WARNING**

Battery replacement

Do not replace batteries unless you have been well informed of maintenance work and safety.

When opening the cabinet and replacing batteries, be careful not to touch any high-voltage circuit (marked with **⚠** and covered with an electric shock prevention cover).

When the electric shock prevention cover has been removed, you will get an electric shock if you touch any high-voltage circuit.

**⚠ WARNING****Fuse replacement**

Before replacing a blown fuse, it is necessary to remove the cause of the blown fuse.

So, do not replace fuses unless you have been well informed of maintenance work and safety.

When opening the cabinet and replacing fuses, be careful not to touch any high-voltage circuit (marked with  and covered with an electric shock prevention cover).

When the electric shock prevention cover has been removed, you will get an electric shock if you touch any high-voltage circuit.

**⚠ CAUTION**

Handle the batteries gently. Do not drop them or give a strong impact to them.

**NOTE**

Each control unit uses batteries, because it must hold data, such as programs, offset values, and parameters even when AC power for it is off.

Back up the data (programs, offset values, and parameters) regularly.

If the battery voltage becomes low, a low battery voltage alarm is displayed on the machine operator's panel or screen.

Once the battery voltage alarm has been displayed, replace the batteries within one week. Otherwise, the memory contents may be lost. The time when the battery for the absolute pulse coder is to be replaced depends on the machine configuration including the detector type. For details, contact the machine tool builder.

For the battery replacement procedure, see Chapter 3 or 4. Recollect or discard old batteries in the way your local autonomous community specifies.



# PREFACE

---

The manual consists of the following chapters:

## Description of this manual

- 1. DISPLAY AND OPERATION**  
This chapter covers those items, displayed on the screen, that are related to maintenance. A list of all supported operations is also provided at the end of this chapter.
- 2. CONTROL UNIT HARDWARE**  
This chapter describes the hardware configuration, printed circuit boards and their mounting positions, and LED display and installation of the control unit.
- 3. REPLACING CONTROL UNIT MAINTENANCE PARTS**  
This chapter describes the replacement of maintenance parts of the control unit.
- 4. MAINTENANCE OF THE OTHER UNITS**  
This chapter describes the basics of maintenance of other units.
- 5. INPUT AND OUTPUT OF DATA**  
This chapter describes the input/output of data, including programs, parameters, and tool compensation data, as well as the input/output procedures for conversational data.
- 6. INTERFACE BETWEEN CNC AND PMC**  
This chapter describes the PMC specifications, the system configuration, and the signals used by the PMC.
- 7. EMBEDDED ETHERNET FUNCTION**  
This chapter describes the embedded Ethernet.
- 8. DIGITAL SERVO**  
This chapter describes the servo tuning screen and how to adjust the reference position return position.
- 9. AC SPINDLE**  
This chapter describes the spindle tuning screen.
- 10. TROUBLESHOOTING**  
This chapter describes the procedures to be followed in the event of certain problems occurring, for example, if the power cannot be turned on or if manual operation cannot be performed. Countermeasures to be applied in the event of alarms being output are also described.
- 11. MOTOR/DETECTOR/AMPLIFIER PREVENTIVE MAINTENANCE**  
This chapter describes the basic information about the preventive maintenance of motors, detectors, and amplifiers.

## APPENDIX

- A. ALARM LIST
- B. LIST OF MAINTENANCE PARTS
- C. BOOT SYSTEM
- D. MEMORY CARD SLOT
- E. LED DISPLAY
- F. MAINTENANCE OF PERSONAL COMPUTER FUNCTIONS (BOOT-UP AND IPL)
- G. MAINTENANCE OF STAND-ALONE TYPE UNIT
- H. ETHERNET DISPLAY FUNCTION
- J. MEMORY CLEAR
- K. USB FUNCTION MAINTENANCE

This manual does not provide a parameter list. If necessary, refer to the separate PARAMETER MANUAL.

## Applicable models

This manual can be used with the following models. The abbreviated names may be used.

Model name	Abbreviation	
FANUC Series 30i-B	30i -B	Series 30i
FANUC Series 31i-B5	31i -B5	Series 31i
FANUC Series 31i-B	31i -B	
FANUC Series 32i-B	32i -B	Series 32i

### NOTE

Some function described in this manual may not be applied to some products.  
For details, refer to the DESCRIPTIONS manual (B-64482EN).

## Related manuals of Series 30i- MODEL B Series 31i- MODEL B Series 32i- MODEL B

The following table lists the manuals related to Series 30i-B, Series 31i-B, Series 32i-B. This manual is indicated by an asterisk(\*).

Table 1 Related manuals

Manual name	Specification	
DESCRIPTIONS	B-64482EN	
CONNECTION MANUAL (HARDWARE)	B-64483EN	
CONNECTION MANUAL (FUNCTION)	B-64483EN-1	
OPERATOR'S MANUAL (Common to Lathe System/Machining Center System)	B-64484EN	
OPERATOR'S MANUAL (For Lathe System)	B-64484EN-1	
OPERATOR'S MANUAL (For Machining Center System)	B-64484EN-2	
MAINTENANCE MANUAL	B-64485EN	*
PARAMETER MANUAL	B-64490EN	
<b>Programming</b>		
Macro Executor PROGRAMMING MANUAL	B-63943EN-2	
Macro Compiler PROGRAMMING MANUAL	B-66263EN	
C Language Executor PROGRAMMING MANUAL	B-63943EN-3	
<b>PMC</b>		
PMC PROGRAMMING MANUAL	B-64513EN	
<b>Network</b>		
PROFIBUS-DP Board CONNECTION MANUAL	B-63993EN	
Fast Ethernet / Fast Data Server OPERATOR'S MANUAL	B-64014EN	
DeviceNet Board CONNECTION MANUAL	B-64043EN	
FL-net Board CONNECTION MANUAL	B-64163EN	
CC-Link Board CONNECTION MANUAL	B-64463EN	
<b>Operation guidance function</b>		
MANUAL GUIDE <i>i</i> (Common to Lathe System/Machining Center System) OPERATOR'S MANUAL	B-63874EN	
MANUAL GUIDE <i>i</i> (For Machining Center System) OPERATOR'S MANUAL	B-63874EN-2	
MANUAL GUIDE <i>i</i> (Set-up Guidance Functions) OPERATOR'S MANUAL	B-63874EN-1	
<b>Dual Check Safety</b>		
Dual Check Safety CONNECTION MANUAL	B-64483EN-2	

## Related manuals of SERVO MOTOR series

The following table lists the manuals related to SERVO MOTOR series

Manual name	Specification
FANUC AC SERVO MOTOR $\alpha i$ series DESCRIPTIONS	B-65262EN
FANUC AC SERVO MOTOR $\beta i s$ series DESCRIPTIONS	B-65302EN
FANUC SYNCHRONOUS BUILT-IN SERVO MOTOR $D i S$ series DESCRIPTIONS	B-65332EN
FANUC LINEAR MOTOR $L i S$ series DESCRIPTIONS	B-65382EN
FANUC AC SPINDLE MOTOR $\alpha i$ series DESCRIPTIONS	B-65272EN
FANUC AC SPINDLE MOTOR $\beta i$ series DESCRIPTIONS	B-65312EN
FANUC BUILT-IN SPINDLE MOTOR $B i l$ series DESCRIPTIONS	B-65292EN
FANUC SYNCHRONOUS BUILT-IN SPINDLE MOTOR $B i S$ series DESCRIPTIONS	B-65342EN
FANUC - NSK SPINDLE UNIT series DESCRIPTIONS	B-65352EN
FANUC SERVO AMPLIFIER $\alpha i$ series DESCRIPTIONS	B-65282EN
FANUC SERVO AMPLIFIER $\beta i$ series DESCRIPTIONS	B-65322EN
FANUC AC SERVO MOTOR $\alpha i$ series FANUC AC SERVO MOTOR $\beta i$ series FANUC LINEAR MOTOR $L i S$ series FANUC SYNCHRONOUS BUILT-IN SERVO MOTOR $D i S$ series PARAMETER MANUAL	B-65270EN
FANUC AC SPINDLE MOTOR $\alpha i / \beta i$ series BUILT-IN SPINDLE MOTOR $B i$ series PARAMETER MANUAL	B-65280EN
FANUC AC SERVO MOTOR $\alpha i s / \alpha i$ series AC SPINDLE MOTOR $\alpha i$ series SERVO AMPLIFIER $\alpha i$ series MAINTENANCE MANUAL	B-65285EN
FANUC AC SERVO MOTOR $\beta i s$ series AC SPINDLE MOTOR $\beta i$ series SERVO AMPLIFIER $\beta i$ series MAINTENANCE MANUAL	B-65325EN
FANUC SERVO AMPLIFIER $\beta i$ series MAINTENANCE MANUAL	B-65395EN
FANUC SERVO GUIDE OPERATOR'S MANUAL	B-65404EN
FANUC AC SERVO MOTOR $\alpha i s / \alpha i / \beta i s$ series SERVO TUNING PROCEDURE (BASIC)	B-65264EN

## Related manuals of FANUC PANEL $i$

The following table lists the manuals related to FANUC PANEL  $i$ .

Manual name	Specification
FANUC PANEL $i$ CONNECTION AND MAINTENANCE MANUAL	B-64223EN

## Related manuals of FANUC I/O Unit

The following table lists the manuals related to FANUC I/O Unit.

Manual name	Specification
FANUC I/O Unit-MODEL A CONNECTION AND MAINTENANCE MANUAL	B-61813E
FANUC I/O Unit-MODEL B CONNECTION AND MAINTENANCE MANUAL	B-62163E
Handy Machine Operator's Panel CONNECTION MANUAL	B-63753EN

## Training

- FANUC runs FANUC Training Center to train those who will be involved in the connection, maintenance, and operation of FANUC products. It is recommended to attend the class so you will be able to use the products effectively.

Visit the following web site for detailed descriptions of its curriculum.

<http://www.fanuc.co.jp/>





# TABLE OF CONTENTS

<b>SAFETY PRECAUTIONS</b> .....	<b>s-1</b>
DEFINITION OF WARNING, CAUTION, AND NOTE .....	s-1
WARNINGS RELATED TO CHECK OPERATION .....	s-2
WARNINGS RELATED TO REPLACEMENT .....	s-3
WARNINGS RELATED TO PARAMETERS .....	s-3
WARNINGS, CAUTIONS, AND NOTES RELATED TO DAILY MAINTENANCE .....	s-4
<b>PREFACE</b> .....	<b>p-1</b>
<b>1 DISPLAY AND OPERATION</b> .....	<b>1</b>
1.1 FUNCTION KEYS AND SOFT KEYS .....	1
1.1.1 Soft Key Structure .....	1
1.1.2 General Screen Operations .....	1
1.1.3 Function Keys .....	2
1.1.4 Soft Keys .....	3
1.2 SYSTEM CONFIGURATION SCREEN .....	9
1.2.1 Display Method .....	9
1.2.2 Hardware Configuration Screen .....	10
1.2.3 Software Configuration Screen .....	11
1.2.4 Outputting System Configuration Data .....	13
1.3 DIAGNOSIS FUNCTION .....	13
1.3.1 Displaying Diagnosis Screen .....	13
1.3.2 Contents Displayed .....	13
1.4 CNC STATE DISPLAY .....	44
1.5 OPERATING MONITOR .....	46
1.5.1 Display Method .....	46
1.5.2 Parameters .....	47
1.6 WAVEFORM DIAGNOSIS DISPLAY .....	48
1.6.1 Waveform Diagnosis Graph Screen .....	48
1.6.2 Waveform Diagnosis Parameter Screen .....	49
1.6.3 Tracing Data .....	58
1.6.4 Outputting Data .....	59
1.7 COLOR SETTING SCREEN .....	65
1.7.1 Screen Display .....	65
1.7.2 Operations for Color Setting .....	65
1.7.3 Parameter .....	66
1.7.4 Notes .....	68
1.8 POWER MATE CNC MANAGER FUNCTION .....	68
1.8.1 Screen Display .....	69
1.8.2 Inputting and Outputting Parameters .....	73
1.8.3 Parameters .....	74
1.8.4 Notes .....	76
1.9 SERVO GUIDE MATE .....	77
1.9.1 Wave Display .....	77
1.9.1.1 Y-time graph .....	78
1.9.1.2 XY graph .....	95
1.9.1.3 Circle graph .....	105
1.9.1.4 Fourier graph .....	114
1.9.1.5 Bode graph .....	120

	1.9.1.6	Parameters.....	129
<b>1.10</b>		<b>MAINTENANCE INFORMATION SCREEN.....</b>	<b>131</b>
	1.10.1	Displaying the Maintenance Information Screen.....	131
	1.10.2	Operating the Maintenance Information Screen.....	132
	1.10.3	Half-Size Kana Input on the Maintenance Information Screen.....	133
	1.10.4	Warnings That Occurs on the Maintenance Information Screen.....	134
	1.10.5	Parameter.....	134
	1.10.6	Overview of the History Function.....	135
	1.10.6.1	Alarm history.....	136
	1.10.6.2	External operator message history.....	138
	1.10.6.3	Operation history.....	142
	1.10.6.4	Operation history signal selection.....	148
	1.10.6.5	Outputting all history data.....	153
<b>1.11</b>		<b>SYSTEM ALARM HISTORY SCREEN.....</b>	<b>156</b>
	1.11.1	System Alarm History List Screen.....	156
	1.11.2	System Alarm History Detail Screen.....	157
	1.11.3	Outputting System Alarm History.....	158
	1.11.4	Parameter.....	158
<b>2</b>		<b>CONTROL UNIT HARDWARE.....</b>	<b>159</b>
<b>2.1</b>		<b>EXAMPLE OF HARDWARE CONFIGURATION.....</b>	<b>159</b>
	2.1.1	Example of the Hardware Configuration of the LCD-mounted Type Control Unit.....	159
	2.1.2	Example of the Hardware Configuration of the Stand-alone Type Control Unit.....	160
<b>2.2</b>		<b>HARDWARE OVERVIEW.....</b>	<b>161</b>
	2.2.1	LCD-mounted Type Control Unit Overview.....	161
	2.2.2	Stand-alone Type Control Unit Overview.....	162
<b>2.3</b>		<b>TOTAL CONNECTION DIAGRAMS.....</b>	<b>163</b>
	2.3.1	Control Unit Connection Diagram.....	163
	2.3.2	Connection Diagram of a Display Unit for the Stand-Alone Type Control Unit.....	167
<b>2.4</b>		<b>HARDWARE OF LCD-MOUNTED TYPE CONTROL UNIT.....</b>	<b>171</b>
	2.4.1	LCD-mounted Type Control Unit (8.4" LCD Unit and 10.4" LCD Unit A).....	171
	2.4.2	LCD-mounted Type Control Unit (10.4" LCD Unit B and 15" LCD Unit).....	180
	2.4.3	LCD-mounted Type Control Unit (with Personal Computer Function with Windows®CE) Hardware.....	188
<b>2.5</b>		<b>HARDWARE OF STAND-ALONE TYPE CONTROL UNIT.....</b>	<b>198</b>
	2.5.1	Stand-alone Type Control Unit.....	198
	2.5.2	Display Unit for Stand-alone Type Control Unit.....	203
	2.5.2.1	Display Unit (10.4" LCD unit A).....	203
	2.5.2.2	Display unit (10.4" LCD unit B and 15" LCD unit).....	206
	2.5.2.3	Display unit for automotive manufacture.....	211
	2.5.3	Display Unit for Stand-Alone Type Control Unit (with Personal Computer Function with Windows®CE).....	219
<b>2.6</b>		<b>HARDWARE OF OPTIONAL BOARDS.....</b>	<b>226</b>
	2.6.1	Fast Ethernet Board.....	226
	2.6.2	Additional axis board.....	228
	2.6.3	HSSB interface board.....	229
	2.6.4	PROFIBUS-DP Board.....	230
	2.6.5	DeviceNet Board.....	233
	2.6.6	CC-Link Board.....	239
<b>2.7</b>		<b>ENVIRONMENTAL REQUIREMENTS OUTSIDE THE CABINET.....</b>	<b>241</b>
	2.7.1	Environmental Conditions outside the Cabinet.....	241
	2.7.2	Installation Conditions of the Control Unit.....	241
<b>2.8</b>		<b>CAUTIONS RELATED TO GROUNDING AND NOISE.....</b>	<b>242</b>

2.8.1	Separating Cables .....	242
2.8.2	Noise Suppressor.....	244
2.8.3	Cable Clamp and Shield Processing.....	245
2.8.4	Lightning Surge Absorber.....	247
<b>3</b>	<b>REPLACING CONTROL UNIT MAINTENANCE PARTS .....</b>	<b>249</b>
3.1	CAUTIONS FOR REPLACEMENT .....	249
3.1.1	Optional Information File.....	250
3.1.2	Attaching and Detaching Units .....	250
3.1.3	Tightening Torque for Fastening Units and Ground Terminals .....	251
3.1.4	Packing .....	251
3.2	REPLACING THE MAIN BOARD .....	253
3.2.1	LCD-mounted Type Control Unit .....	253
3.2.2	Stand-alone Type Control Unit .....	255
3.3	REPLACING THE DISPLAY CONTROL BOARD FOR THE DISPLAY UNIT .....	256
3.4	REPLACING LCD UNITS .....	257
3.4.1	LCD-mounted Type Control Unit (8.4" LCD Unit and 10.4" LCD Unit) .....	257
3.4.2	Display Unit for Stand-alone Type Control Unit (10.4" LCD Unit).....	258
3.5	MOUNTING AND DEMOUNTING CARD PCBS .....	259
3.6	MOUNTING AND DEMOUNTING FROM/SRAM MODULE .....	261
3.7	ATTACHING A COMPACT FLASH CARD ONTO, AND DETACHING IT FROM, A PRINTED CIRCUIT BOARD .....	262
3.8	INSERTING AND EXTRACTING OPTIONAL BOARDS .....	263
3.9	REPLACING FUSES .....	265
3.9.1	LCD-mounted Type Control Unit .....	266
3.9.2	LCD-mounted Type Control Unit (Personal Computer Function with Windows <sup>®</sup> CE) .....	267
3.9.3	Stand-alone Type Control Unit .....	267
3.9.4	Display Unit for Stand-alone Type Control Unit .....	268
3.9.4.1	Display unit (10.4" LCD unit A) .....	268
3.9.4.2	Display unit (10.4" LCD unit B and 15" LCD unit) .....	268
3.9.4.3	Display unit for Automotive manufacture .....	269
3.9.5	Replacing the Fuse on the Display Unit for the Stand-Alone Type Control Unit (with PC Functions Supporting Windows <sup>®</sup> CE) .....	269
3.10	REPLACING THE MEMORY BACKUP BATTERY IN THE CONTROL UNIT .....	270
3.10.1	Replacing a Lithium Battery .....	270
3.10.2	Replacing a Commercial D-size Alkaline Dry Cells .....	273
3.11	REPLACING A FAN .....	274
3.11.1	LCD-mounted Type Control Unit .....	274
3.11.2	Stand-alone Type Control Unit .....	275
3.11.3	Display Unit for Automotive.....	276
3.11.4	Display Unit for Stand-alone Type Control Unit (Personal Computer Function with Windows <sup>®</sup> CE) .....	277
3.12	REPLACING THE PROTECTION COVER.....	278
3.13	REPLACING THE TOUCH PANEL PROTECTION SHEET .....	279
3.14	TOUCH PANEL CALIBRATION .....	280
3.15	REPLACING THE BACKUP UNIT .....	284
<b>4</b>	<b>MAINTENANCE OF THE OTHER UNITS .....</b>	<b>285</b>
4.1	CAUTIONS COMMON TO THE OTHER UNITS .....	285

4.2	UNITS SUPPORTING I/O Link <i>i</i> .....	285
4.2.1	Items Common to Units Supporting I/O Link <i>i</i> .....	285
4.2.2	I/O Module for Connector Panel [Supporting I/O Link <i>i</i> ].....	286
4.2.3	I/O Module for Operator's Panel (Supporting Matrix Input) [Supporting I/O Link <i>i</i> ].....	289
4.2.4	Connection of I/O Module for Operator's Panel and I/O Module for Power Magnetics Cabinet [Supporting I/O Link <i>i</i> ].....	290
4.2.5	I/O Module Type-2 for Connector Panel [Supporting I/O Link <i>i</i> ] .....	291
4.2.6	Terminal Type I/O Module [Supporting I/O Link <i>i</i> ] .....	293
4.2.7	I/O Link Connection Unit [Supporting I/O Link <i>i</i> ] .....	298
4.2.8	Standard Machine Operator's Panel [Supporting I/O Link <i>i</i> ] .....	300
4.3	UNITS SUPPORTING I/O Link.....	302
4.3.1	I/O Link-AS- <i>i</i> Converter .....	302
4.4	SEPARATE DETECTOR INTERFACE UNIT .....	310
4.5	Analog Input Separate Detector Interface Unit .....	311
4.6	PANEL <i>i</i> .....	312
4.6.1	Replacing the Battery .....	312
4.6.2	Replacing the Fan.....	314
4.6.2.1	Replacing the fan in the PANEL <i>i</i> .....	314
4.6.2.2	Replacing the fan for the HDD.....	315
4.6.3	Replacing the Touch Panel Protection Sheet.....	315
4.7	REPLACING BATTERY FOR ABSOLUTE PULSECODERS.....	316
4.7.1	Overview .....	316
4.7.2	Replacing Batteries.....	316
4.7.3	Replacing the Batteries in a Separate Battery Case.....	317
4.7.4	Replacing the Battery Built into the Servo Amplifier .....	317
<b>5</b>	<b>INPUT AND OUTPUT OF DATA.....</b>	<b>319</b>
5.1	SETTING PARAMETERS FOR INPUT/OUTPUT.....	319
5.2	INPUTTING/ OUTPUTTING DATA.....	320
5.2.1	Confirming the Parameters Required for Data Output.....	321
5.2.2	Outputting CNC Parameters.....	322
5.2.3	Outputting Pitch Error Compensation Amount.....	323
5.2.4	Outputting Custom Macro Variable Values .....	323
5.2.5	Outputting Tool Compensation Amount .....	323
5.2.6	Outputting Part Program .....	323
5.2.7	Inputting CNC Parameters .....	324
5.2.8	Inputting Pitch Error Compensation Amount.....	325
5.2.9	Inputting Custom Macro Variable Values.....	326
5.2.10	Inputting Tool Compensation Amount.....	326
5.2.11	Inputting Part Programs.....	326
5.3	AUTOMATIC DATA BACKUP .....	327
<b>6</b>	<b>INTERFACE BETWEEN CNC AND PMC.....</b>	<b>332</b>
6.1	WHAT IS PMC?.....	332
6.1.1	Basic Configuration of PMC.....	332
6.1.2	I/O Signals of PMC .....	332
6.1.3	PMC Signal Addresses .....	333
6.1.4	Communication Method for External I/O Device .....	335
6.2	MULTI-PMC FUNCTION .....	336
6.2.1	Execution Order and Execution Time Percentage.....	337
6.2.2	Setting I/O Address for I/O Link <i>i</i> and I/O Link.....	338
6.2.3	Interface Between CNC and PMC .....	339

6.2.4	Multi-Path PMC Interface .....	340
6.2.5	System Relay Addresses (R9000, Z0).....	341
<b>6.3</b>	<b>PMC SPECIFICATIONS .....</b>	<b>346</b>
6.3.1	Basic Specifications .....	346
6.3.2	Addresses.....	350
<b>6.4</b>	<b>OPERATING THE PMC SCREEN.....</b>	<b>352</b>
6.4.1	Transition of the PMC Screens.....	354
<b>6.5</b>	<b>PMC DIAGNOSIS AND MAINTENANCE SCREENS ([PMC MAINTE]) ....</b>	<b>355</b>
6.5.1	Monitoring PMC Signal Status ([STATUS] Screen) .....	355
6.5.2	Checking PMC Alarms ([PMC ALARM] Screen).....	356
6.5.3	Setting and Displaying Variable Timers ([TIMER] Screen).....	357
6.5.4	Setting and Displaying Counter Values ([COUNTR] Screen).....	359
6.5.5	Setting and Displaying Keep Relays ([KEEP RELAY] Screen).....	360
6.5.6	Setting and Displaying Data Tables ([DATA] Screen).....	361
6.5.7	Data Input/Output ([I/O] Screen) .....	367
6.5.8	Displaying i/o devices connection status ([I/O DEVICE] screen) .....	370
6.5.9	Signal Trace Function ([TRACE] Screen) .....	372
6.5.10	Setting of Trace Parameter ([TRACE SETING] Screen).....	373
6.5.11	Execution of Trace .....	376
6.5.11.1	Operation after execution of trace .....	377
6.5.11.2	Automatic start of trace setting .....	380
6.5.12	MONITORING I/O DIAGNOSIS ([I/O DGN] SCREEN) .....	380
<b>6.6</b>	<b>LADDER DIAGRAM MONITOR AND EDITOR SCREENS</b>	
	<b>([PMC LADDER]).....</b>	<b>384</b>
6.6.1	Displaying a Program List ([LIST] Screen) .....	385
6.6.2	Monitoring Ladder Diagrams ([LADDER] Screen).....	386
6.6.3	Editing Ladder Programs.....	389
6.6.3.1	NET EDITOR screen.....	391
6.6.4	PROGRAM LIST EDITOR Screen .....	393
6.6.5	Collective Monitor Function .....	394
6.6.5.1	COLLECTIVE MONITOR function.....	395
<b>6.7</b>	<b>LIST OF ADDRESSES .....</b>	<b>398</b>
<b>7</b>	<b>EMBEDDED ETHERNET FUNCTION .....</b>	<b>435</b>
7.1	EMBEDDED ETHERNET PORT AND PCMCIA ETHERNET CARD.....	435
7.2	SETTING UP THE EMBEDDED ETHERNET FUNCTION .....	437
7.2.1	Setting of the FOCAS2/Ethernet.....	437
7.2.1.1	Operation on the FOCAS2/Ethernet setting screen .....	438
7.2.1.2	Example of setting the FOCAS2/Ethernet function.....	440
7.2.2	Setting of the FTP File Transfer Function.....	440
7.2.2.1	Operation on the FTP file transfer setting screen .....	441
7.2.2.2	Related NC parameters .....	443
7.2.2.3	Example of setting the FTP file transfer function.....	443
7.2.3	Setting Up the DNS/DHCP Function.....	444
7.2.3.1	Setting up DNS.....	444
7.2.3.2	Setting up DHCP .....	445
7.2.3.3	Related NC parameters .....	447
7.2.4	Setting of the Unsolicited Messaging Function.....	448
7.2.4.1	Overview .....	448
7.2.4.2	Setting of the FOCAS2/Ethernet function .....	449
7.2.4.3	Mode selection.....	452
7.2.4.4	Setting on the CNC screen.....	454
7.2.4.5	Setting on the personal computer.....	457
7.2.4.6	Execution methods.....	457

7.2.4.7	Related NC parameters .....	463
7.2.5	Backing Up and Restoring Communication Parameters .....	464
7.3	SWITCHING BETWEEN THE EMBEDDED ETHERNET DEVICES .....	466
7.4	EMBEDDED ETHERNET OPERATIONS.....	466
7.4.1	FTP File Transfer Function .....	466
7.4.1.1	Displaying and operating the file list.....	469
7.5	RESTART OF THE EMBEDDED ETHERNET .....	470
7.6	MAINTENANCE SCREEN FOR EMBEDDED ETHERNET FUNCTION ...	471
7.7	LOG SCREEN OF THE EMBEDDED ETHERNET FUNCTION .....	474
<b>8</b>	<b>DIGITAL SERVO .....</b>	<b>479</b>
8.1	INITIAL SETTING SERVO PARAMETERS.....	479
8.2	FSSB SETTING SCREEN.....	489
8.3	SERVO TUNING SCREEN.....	501
8.3.1	Parameter Setting .....	501
8.3.2	Displaying Servo Tuning Screen.....	501
8.4	ADJUSTING REFERENCE POSITION (DOG METHOD) .....	502
8.5	DOGLESS REFERENCE POSITION SETTING .....	505
8.6	$\alpha$ i SERVO WARNING INTERFACE .....	506
8.7	$\alpha$ i SERVO INFORMATION SCREEN.....	509
<b>9</b>	<b>AC SPINDLE .....</b>	<b>514</b>
9.1	SERIAL INTERFACE AC SPINDLE .....	515
9.1.1	Outline of Spindle Control .....	515
9.1.1.1	Method A of gear change for machining center system (bit 2 (SGB) of Parameter No.3705 = 0) .....	516
9.1.1.2	Method B of gear change for machining center system (bit 2 (SGB) of Parameter No.3705 = 1) .....	516
9.1.1.3	Lathe system .....	516
9.1.2	Spindle Setting and Tuning Screen .....	517
9.1.2.1	Display method.....	517
9.1.2.2	Spindle setting screen .....	517
9.1.2.3	Spindle tuning screen.....	519
9.1.2.4	Spindle monitor screen .....	520
9.1.2.5	Correspondence between operation mode and parameters on spindle tuning screen .....	522
9.1.3	Automatic Setting of Standard Parameters.....	524
9.1.4	Warning Interface.....	525
9.1.5	Spindle Information Screen.....	527
<b>10</b>	<b>TROUBLESHOOTING .....</b>	<b>532</b>
10.1	CORRECTIVE ACTION FOR FAILURES.....	532
10.1.1	Investigating the Conditions under which Failure Occurred.....	533
10.2	NO MANUAL OPERATION NOR AUTOMATIC OPERATION CAN BE EXECUTED .....	534
10.3	JOG OPERATION CANNOT BE DONE .....	537
10.4	HANDLE OPERATION CANNOT BE DONE .....	540
10.5	AUTOMATIC OPERATION CANNOT BE DONE .....	544
10.6	CYCLE START LED SIGNAL HAS TURNED OFF.....	549
10.7	NOTHING IS DISPLAYED ON THE LCD WHEN THE POWER IS TURNED ON .....	550

10.8	INPUT FROM AND OUTPUT TO I/O DEVICES CANNOT BE PERFORMED, INPUT/OUTPUT CANNOT BE PERFORMED PROPERLY .....	551
10.9	IN A CONNECTOR PANEL I/O UNIT, DATA IS INPUT TO AN UNEXPECTED ADDRESS .....	553
10.10	IN A CONNECTOR PANEL I/O UNIT, NO DATA IS OUTPUT TO AN EXPANSION UNIT .....	554
10.11	ALARM SR0085 TO SR0087 (READER/PUNCHER INTERFACE ALARM) .....	555
10.12	ALARM PS0090 (REFERENCE POSITION RETURN IS ABNORMAL) ....	559
10.13	ALARM DS0300 (REQUEST FOR REFERENCE POSITION RETURN) ..	560
10.14	ALARM SV0401 (V READY OFF) .....	561
10.15	ALARM SV0404 (V READY ON) .....	563
10.16	ALARM SV0462 (SEND CNC DATA FAILED) ALARM SV0463 (SEND SLAVE DATA FAILED) .....	563
10.17	ALARM SV0417 (DIGITAL SERVO SYSTEM IS ABNORMAL) .....	564
10.18	ALARM OH0700 (OVERHEAT: CONTROL UNIT) .....	564
10.19	ALARM OH0701 (OVERHEAT: FAN MOTOR) .....	565
10.20	ALARM SV5134 (FSSB: OPEN READY TIME OUT) ALARM SV5137 (FSSB: CONFIGURATION ERROR) ALARM SV5197 (FSSB: OPEN TIME OUT) .....	565
10.21	ALARM SV5136 (FSSB: NUMBER OF AMPS IS SMALL) .....	566
10.22	SERVO ALARMS .....	566
10.23	SPINDLE ALARMS .....	566
10.24	SYSTEM ALARMS .....	566
	10.24.1 Overview .....	566
	10.24.2 Operations on the System Alarm Screen .....	568
	10.24.3 System Alarms Detected by Hardware .....	571
	10.24.4 System Alarms 114 to 160 (Alarms on the FSSB) .....	572
10.25	SYSTEM ALARMS RELATED TO THE PMC AND I/O Link .....	575
	System alarms 197, 199 (PMC general) .....	576
	System alarm 196 (PMC watchdog) .....	578
	System alarm 195 (related to the I/O Link) .....	579
	System alarm 194 (related to the I/O Link <i>i</i> ) .....	580
10.26	LEDS ON UNITS SUPPORTING I/O LINK <i>i</i> .....	584
	10.26.1 Meanings of LEDs on units supporting I/O Link <i>i</i> .....	584
	10.26.2 Unit's LED on I/O Link <i>i</i> .....	586
	10.26.3 Unit's LED on I/O Link .....	590
<b>11</b>	<b>MOTOR/DETECTOR/AMPLIFIER PREVENTIVE MAINTENANCE ...</b>	<b>593</b>
11.1	LIST OF MANUALS RELATED TO MOTORS AND AMPLIFIERS .....	594
11.2	PREVENTIVE MAINTENANCE OF MOTORS AND DETECTORS .....	595
	11.2.1 Warnings, Cautions, and Notes on Preventive Maintenance of Motors and Detectors .....	595
	11.2.2 Preventive Maintenance of a Motor (Common to All Models) .....	597
	11.2.2.1 Main inspection items .....	597
	11.2.2.2 Periodic cleaning of a motor .....	599
	11.2.2.3 Notes on motor cleaning .....	600
	11.2.2.4 Notes on the cutting fluid (informational) .....	600
	11.2.3 Preventive Maintenance of a Built-in Spindle Motor and Spindle Unit .....	600

11.2.3.1	Routine inspection of the FANUC-NSK spindle unit .....	601
11.2.3.2	Maintenance of the FANUC-NSK spindle unit .....	601
11.2.3.3	Test run of the FANUC-NSK spindle unit .....	602
11.2.3.4	Storage method of the FANUC-NSK spindle unit .....	602
11.2.4	Preventive Maintenance of a Linear Motor .....	602
11.2.4.1	Appearance inspection of the linear motor (magnet plate) .....	602
11.2.5	Maintenance of a Detector.....	603
11.2.5.1	Alarms for built-in detectors ( $\alpha$ i and $\beta$ i Pulsecoders) and troubleshooting actions.....	603
11.2.5.2	Alarms for separate detectors and troubleshooting actions .....	604
11.2.5.3	Detailed troubleshooting methods .....	604
11.2.5.4	Maintenance of $\beta$ iS motor Pulsecoders .....	606
11.3	<b>PREVENTIVE MAINTENANCE OF SERVO AMPLIFIERS .....</b>	<b>607</b>
11.3.1	Warnings, Cautions, and Notes on Preventive Maintenance of Servo Amplifiers.....	607
11.3.2	Preventive Maintenance of a Servo Amplifier .....	610
11.3.3	Maintenance of a Servo Amplifier .....	611
11.3.3.1	Display of the servo amplifier operation status .....	611
11.3.3.2	Replacement of a fan motor.....	613

## APPENDIX

<b>A</b>	<b>ALARM LIST .....</b>	<b>617</b>
A.1	ALARM LIST (CNC).....	617
A.2	ALARM LIST (PMC) .....	681
A.2.1	Messages That May Be Displayed on the PMC Alarm Screen .....	681
A.2.2	PMC System Alarm Messages .....	690
A.2.3	Operation Errors .....	695
A.2.4	I/O Communication Error Messages .....	710
A.3	ALARM LIST (SERIAL SPINDLE) .....	715
A.4	ERROR CODES (SERIAL SPINDLE).....	727
<b>B</b>	<b>LISTS OF UNITS, PRINTED CIRCUIT BOARDS, AND CONSUMABLES.....</b>	<b>730</b>
B.1	UNITS AND PRINTED CIRCUIT BOARDS FOR LCD-MOUNTED TYPE CONTROL UNIT.....	730
B.2	UNITS AND PRINTED CIRCUIT BOARDS FOR STAND-ALONE TYPE CONTROL UNIT.....	731
B.3	PRINTED CIRCUIT BOARDS COMMON TO LCD-MOUNTED AND STAND-ALONE TYPE CONTROL UNITS.....	735
B.4	PRINTED CIRCUIT BOARDS AND UNITS UNIQUE TO PERSONAL COMPUTER FUNCTION WITH Windows® CE .....	736
B.4.1	Personal computer function with Windows® CE for LCD-mounted type Control Unit.....	736
B.4.2	Personal computer function with Windows® CE for Stand-alone type Control Unit.....	737
B.5	MDI UNIT .....	740
B.6	OTHER UNITS .....	740
B.7	Consumables.....	742
<b>C</b>	<b>BOOT SYSTEM.....</b>	<b>744</b>
C.1	OVERVIEW .....	744



C.1.1	Displaying the Power ON Sequence .....	745
C.1.2	Starting the Boot System .....	745
C.1.3	System Files and User Files .....	746
<b>C.2</b>	<b>SCREEN CONFIGURATION AND OPERATING PROCEDURE .....</b>	<b>747</b>
C.2.1	USER DATA LOADING/SYSTEM DATA LOADING Screen.....	748
C.2.2	SYSTEM DATA CHECK Screen.....	750
C.2.3	SYSTEM DATA DELETE Screen .....	752
C.2.4	SYSTEM DATA SAVE Screen.....	754
C.2.5	SRAM DATA UTILITY Screen .....	755
C.2.6	MEMORY CARD FORMAT Screen.....	757
C.2.7	LOAD BASIC SYSTEM .....	758
C.2.8	Cautions.....	758
<b>C.3</b>	<b>ERROR MESSAGES AND REQUIRED ACTIONS .....</b>	<b>759</b>
<b>D</b>	<b>MEMORY CARD SLOT.....</b>	<b>761</b>
D.1	OVERVIEW .....	761
D.2	MEMORY CARD TYPES (FUNCTIONS) .....	761
D.3	HARDWARE CONFIGURATION .....	763
<b>E</b>	<b>LED DISPLAY .....</b>	<b>764</b>
E.1	OVERVIEW .....	764
E.2	7-SEGMENT LED INDICATIONS (TURNED ON) .....	764
E.3	7-SEGMENT LED INDICATIONS (BLINKING).....	766
<b>F</b>	<b>MAINTENANCE OF PERSONAL COMPUTER FUNCTIONS</b>	
	<b>(BOOT-UP AND IPL) .....</b>	<b>767</b>
F.1	OVERVIEW .....	767
F.2	CHANGING START SEQUENCES .....	769
F.3	EXPLANATION OF SCREENS .....	770
F.3.1	BOOT Screen .....	770
F.3.1.1	User data manipulation.....	771
F.3.1.2	SRAM operation.....	772
F.3.1.3	File operation .....	773
F.3.2	IPL Screen .....	773
F.3.2.1	Functions on the IPL screen .....	774
F.4	OTHER SCREENS.....	774
F.4.1	CNC Alarm Screen.....	774
F.4.2	Status Screen (Personal Computer Functions with WindowsXP only).....	775
F.4.3	Option Setting Screen.....	775
F.4.3.1	Option setting screen (Personal Computer Functions with WindowsXP).....	776
F.4.3.2	Option setting screen (Personal Computer Functions with WindowsCE).....	777
<b>G</b>	<b>MAINTENANCE OF STAND-ALONE TYPE UNIT.....</b>	<b>782</b>
G.1	OVERVIEW .....	782
G.2	OPERATION.....	782
G.3	OPERATION OF EACH FUNCTION .....	783
<b>H</b>	<b>ETHERNET DISPLAY FUNCTION .....</b>	<b>786</b>
H.1	OVERVIEW .....	786
H.2	EXAMPLE OF NETWORK CONFIGURATION.....	788
H.3	DISPLAY UNIT NUMBER SETTING AND CONFIRMATION .....	790
H.3.1	Display Unit Number Setting .....	790

	H.3.2	Display Unit Number Confirmation .....	791
H.4		<b>NODE NUMBER SETTING AND CONFIRMATION .....</b>	<b>792</b>
	H.4.1	Method of Node Number Setting .....	792
	H.4.2	Method of Node Number Confirmation .....	792
H.5		<b>CHANGING START SEQUENCES .....</b>	<b>793</b>
H.6		<b>NCBOOT32E.exe .....</b>	<b>794</b>
	H.6.1	Boot Screen .....	795
	H.6.2	File Storage Location Selection.....	796
	H.6.3	User Data Operation.....	796
	H.6.4	S-RAM Operation .....	797
	H.6.5	File Operation.....	798
	H.6.6	IPL Screen .....	799
	H.6.7	CNC Alarm Screen.....	800
	H.6.8	Status Screen .....	800
	H.6.9	Option Setting Screen.....	801
	H.6.10	Changer Screen.....	802
H.7		<b>STARTING OF THE CNC SCREEN DISPLAY FUNCTION .....</b>	<b>803</b>
<b>I</b>		<b>IPL MONITOR .....</b>	<b>805</b>
	I.1	OVERVIEW .....	805
	I.2	STARTING OF THE IPL MONITOR .....	805
	I.3	IPL MENU.....	806
<b>J</b>		<b>MEMORY CLEAR .....</b>	<b>808</b>
	J.1	OVERVIEW .....	808
	J.2	OPERATION METHOD .....	808
	J.3	DATA TYPES TO BE CLEARED.....	809
<b>K</b>		<b>USB FUNCTION MAINTENANCE .....</b>	<b>811</b>
	K.1	USB FUNCTION MAINTENANCE SCREEN .....	811
	K.2	USB FUNCTION LOG SCREEN .....	813

# 1 DISPLAY AND OPERATION

This chapter describes how to display various screens by the function keys. The screens used for maintenance are respectively displayed.

- 1.1 FUNCTION KEYS AND SOFT KEYS ..... 1
- 1.2 SYSTEM CONFIGURATION SCREEN ..... 9
- 1.3 DIAGNOSIS FUNCTION ..... 13
- 1.4 CNC STATE DISPLAY ..... 44
- 1.5 OPERATING MONITOR..... 46
- 1.6 WAVEFORM DIAGNOSIS DISPLAY ..... 48
- 1.7 COLOR SETTING SCREEN ..... 65
- 1.8 POWER MATE CNC MANAGER FUNCTION ..... 68
- 1.9 SERVO GUIDE MATE ..... 77
- 1.10 MAINTENANCE INFORMATION SCREEN ..... 131
- 1.11 SYSTEM ALARM HISTORY SCREEN ..... 156

## 1.1 FUNCTION KEYS AND SOFT KEYS

Operations and soft key display status for each function key are described below:

### 1.1.1 Soft Key Structure

The function keys are used to select the type of screen (function) to be displayed. When a soft key (section select soft key) is pressed immediately after a function key, the screen (section) corresponding to the selected function can be selected.

### 1.1.2 General Screen Operations

**- Procedure**

- 1 By pressing a function key on the MDI panel, the chapter selection soft keys that belong to the function are displayed.

Example 1)

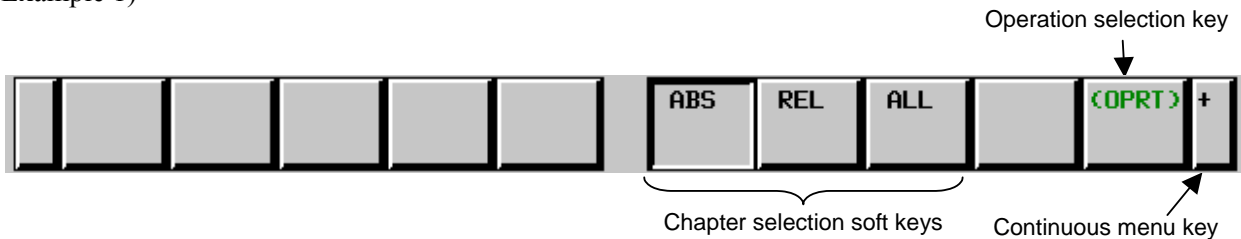

- 2 When one of the chapter selection soft keys is pressed, the screen of the chapter is displayed. If the soft key of a desired chapter is not displayed, press the continuous menu key. In a chapter, a further choice may be made from multiple chapters.
- 3 When the screen of a desired chapter is displayed, press the operation selection key to display operations to be performed.
- 4 Select a desired operation with the operation selection soft key. Depending on the operation to be executed, an auxiliary menu of soft keys is displayed. Perform an operation according to the indications on the auxiliary menu.

Example 2)

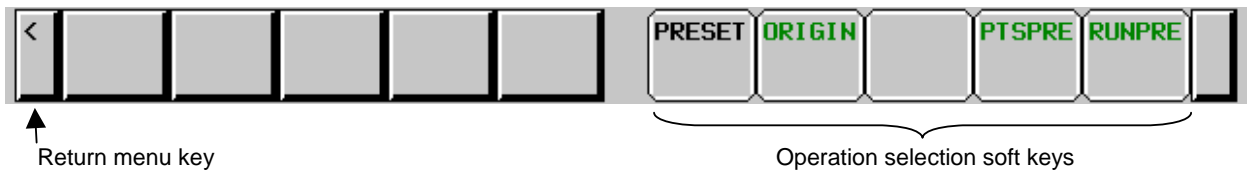

Example 3)

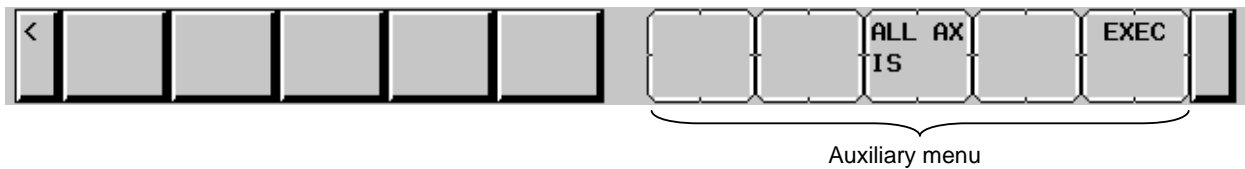

5 To return to the display of chapter selection soft keys, press the return menu key.

A general screen display procedure is provided above. The actual display procedure varies from one screen to another.

For details, see each description of operation.

**- Button design change depending on soft key state**

The soft keys assume one of the following states, depending on the selection target:

- Chapter selection soft keys
- Operation selection soft keys
- Auxiliary menu of operation selection soft keys

Depending on the state, the button images of the soft keys change.

From the button images, which state the soft keys are assuming can be known.

Example)

- Chapter selection soft keys



- Operation selection soft keys



- Auxiliary menu of operation selection soft keys

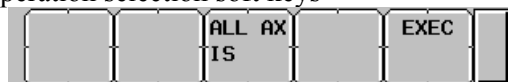

### 1.1.3 Function Keys

Function keys are provided to select the type of screen to be displayed. The following function keys are provided on the MDI panel:

Press this key to display the position screen.



Press this key to display the program screen.



Press this key to display the offset/setting screen.



Press this key to display the system screen.



Press this key to display the message screen.



Press this key to display the graphics screen.



Press this key to display the custom screen 1 (conversational macro screen or C Language Executor screen).



Press this key to display the custom screen 2 (conversational macro screen or C Language Executor screen).



## 1.1.4 Soft Keys

By pressing a soft key after a function key, the corresponding screen of the function can be displayed.

The chapter selection soft keys of each function are described below.

The horizontal four keys on the right-hand side are assigned to chapter selection soft keys. When multiple pages are used for chapter selection soft keys, [+] is displayed on the continuous menu key (rightmost soft key). Press the continuous menu key to switch between chapter selection soft keys.

### NOTE

- 1 Press function keys to switch between screens that are used frequently.
- 2 Some soft keys are not displayed depending on the option configuration.

If position indications are provided on the left half of the screen when a key other than the function key



is pressed, the left half of the soft keys is displayed as follows at all times:

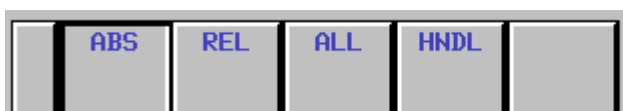

**Position display screen**

The chapter selection soft keys that belong to the function key  and the function of each screen are described below.

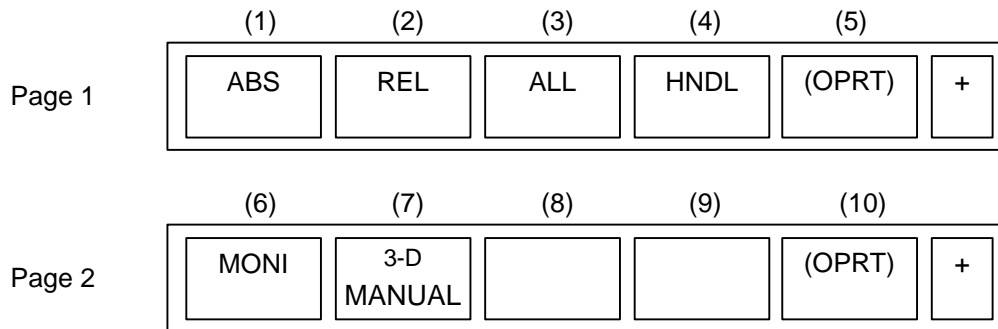
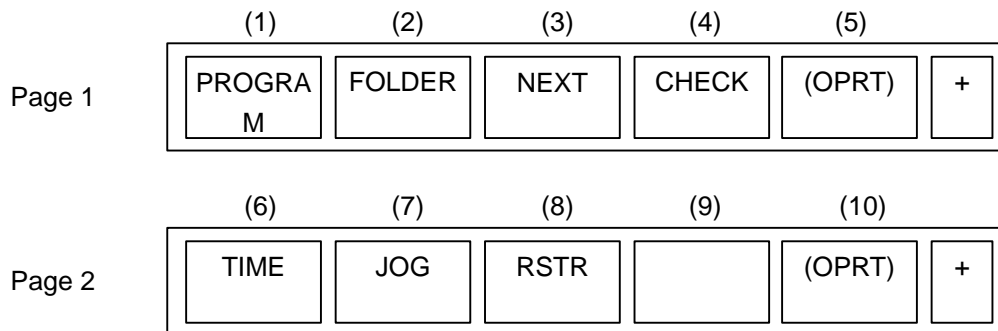

**Table 1.1.4 (a) Position display screen**

No.	Chapter menu	Description
(1)	ABS	Selects the absolute coordinate display screen.
(2)	REL	Selects the relative coordinate display screen.
(3)	ALL	Selects the overall coordinate display screen.
(4)	HNDL	Selects the operation screen for manual handle operation.
(6)	MONI	Selects the screen for displaying the servo axis load meter, serial spindle load meter, and speedometer.
(7)	3-D MANUAL	Displays a handle pulse interrupt amount in three-dimensional manual feed.

**Program screen**

The chapter selection soft keys that belong to the function key  and the function of each screen are described below.

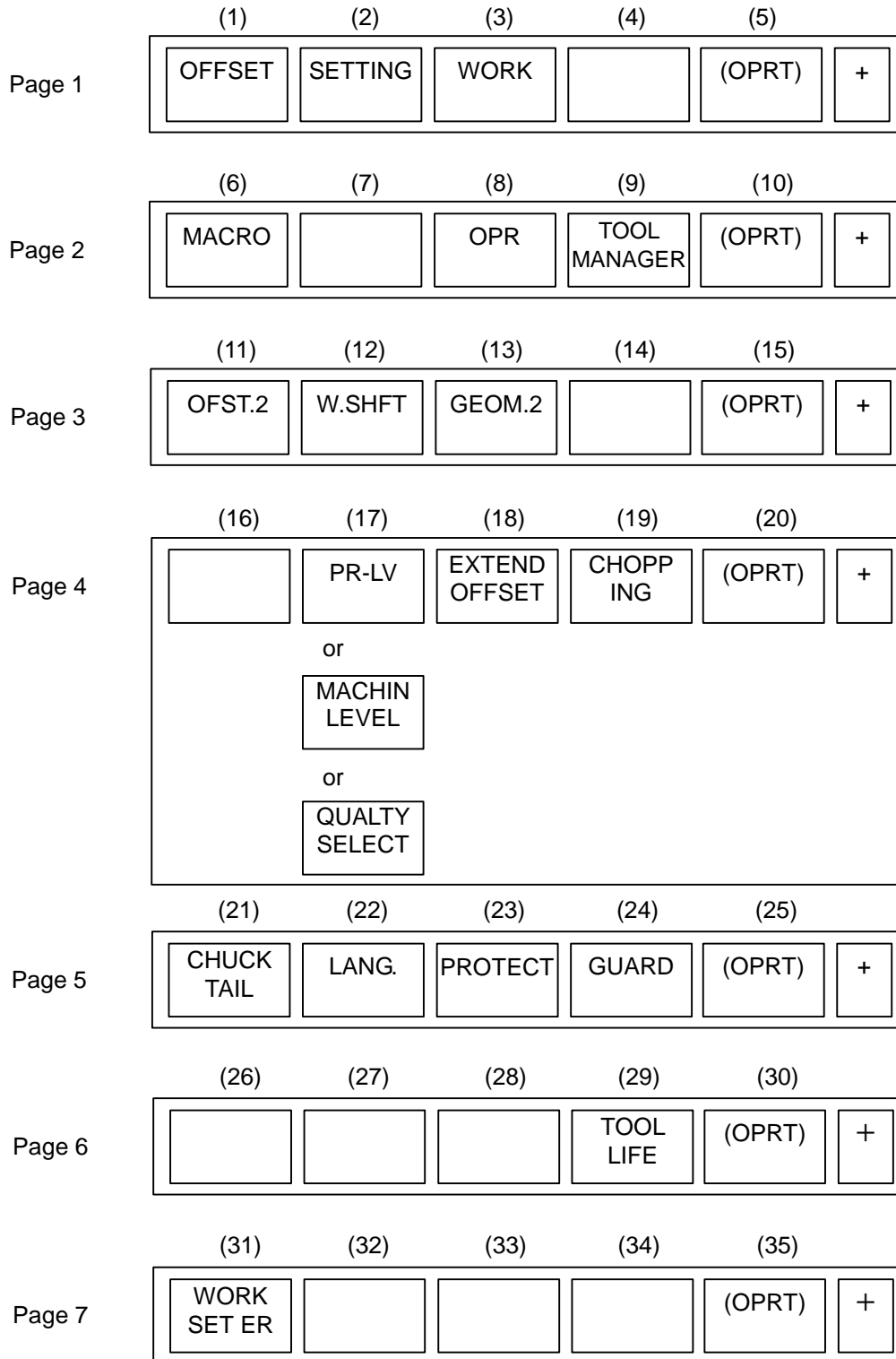

**Table 1.1.4 (b) Program**

No.	Chapter menu	Description
(1)	PROGRAM	Selects the screen for displaying a list of part programs currently registered.
(2)	FOLDER	Selects the screen for displaying a list of part programs currently registered.
(3)	NEXT	Selects the screen for displaying the command values of the block currently executed and the next block to be executed among the command values.
(4)	CHECK	Selects the screen for displaying programs, position data, modal information, and so forth simultaneously.
(6)	TIME	Selects the screen for displaying executed program operation time.
(7)	JOG	Selects the screen for executing, in the JOG mode, data specified in the program format from the MDI.
(8)	RSTR	Selects the operation screen for restarting an interrupted program operation.

**Offset/setting screen**

The chapter selection soft keys that belong to the function key  and the function of each screen are described below.



**Table 1.1.4 (c) Offset**

No.	Chapter menu	Description
(1)	OFFSET	Selects the screen for setting tool offset values.
(2)	SETTING	Selects the screen for setting the setting parameters.

No.	Chapter menu	Description
(3)	WORK	Selects the screen for setting a workpiece coordinate system offset.
(6)	MACRO	Selects the screen for setting macro variables.
(8)	OPR	Selects the screen for operating some operation switches on the machine operator's panel as soft switches.
(9)	TOOL MANAGER	Selects the screen for setting data related to tool management.
(11)	OFST.2	Selects the screen for setting a Y-axis offset.
(12)	W.SHFT	Selects the screen for setting a workpiece coordinate system shift value.
(13)	GEOM.2	Selects the screen for setting a second geometry offset.
(17)	PR-LV	Selects the screen for setting a precision level.
	MACHIN LEVEL	Selects the screen for setting a precision level or smoothing level.
	QUALTY SELECT	
(18)	EXTEND OFFSET	Selects the screen for setting the offsets of the fourth and fifth axes.
(21)	CHUCK TAIL	Selects the chuck tail stock barrier screen.
(22)	LANG.	Selects the screen for setting a display language.
(23)	PROTECT	Selects the screen for setting data protection.
(24)	GUARD	Selects the screen for setting wrong operation prevention.
(29)	TOOL LIFE	Selects the screen for operations and setting related to tool life management.
(31)	WRK ERR COMP	Selects the screen for setting errors related to workpiece mounting position.

**System screen**

The chapter selection soft keys that belong to the function key  and the function of each screen are described below.

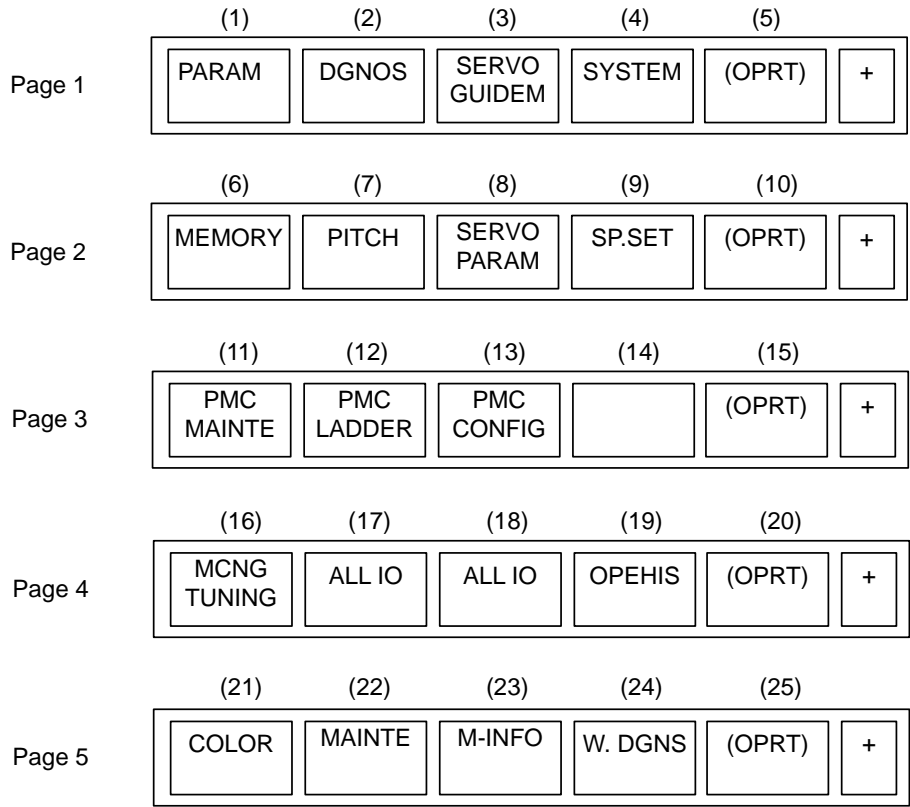



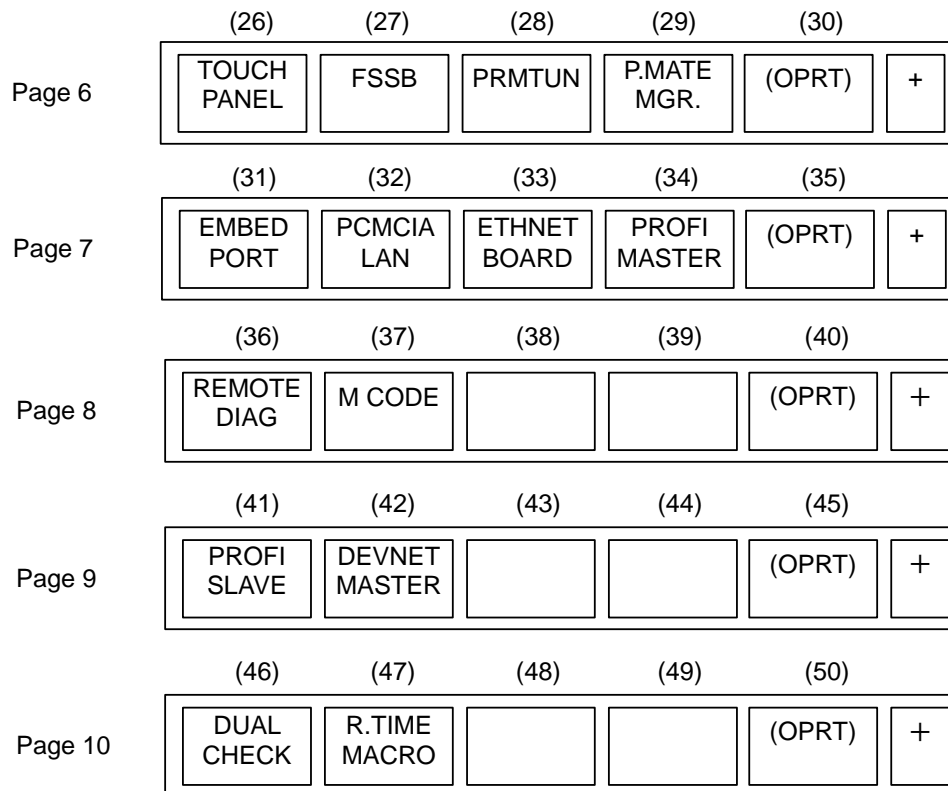



Table 1.1.4 (d) System

No.	Chapter menu	Description
(1)	PARAM	Selects the screen for setting parameters.
(2)	DGNOS	Selects the screen for displaying CNC state.
(3)	SERVO GUIDEM	Selects the screen for displaying the servo guide mate.
(4)	SYSTEM	Selects the screen for displaying the current system status.
(6)	MEMORY	Selects the screen for displaying the contents of memory.
(7)	PITCH	Selects the screen for setting pith error compensation.
(8)	SERVO PARAM	Selects the screen for setting the servo-related parameters.
(9)	SP.SET	Selects the screen for spindle-related setting.
(11)	PMC MAINTEN	Selects the screen related to PMC maintenance such as PMC signal state monitoring and tracing, and PMC parameter display/editing.
(12)	PMC LADDER	Selects the screen related to ladder display/editing.
(13)	PMC CONFIG	Displays the screen for displaying/editing data other than ladders that makes up a sequence program and for setting the PMC function.
(16)	MCNG TUNING	Displays the screen for setting the parameter set for emphasis on speed (LV1), emphasis on precision (LV10), or smoothing level (LV1 or LV10).
(17)	ALL IO	Selects the screen for data input and output.
(18)	ALL IO	Selects the screen for data input to and output from the memory card.
(19)	OPEHIS	Selects the screen for displaying the history of operations performed by the operator and issued alarms.
(21)	COLOR	Selects the screen for setting colors to be used on the screen.
(22)	MAINTEN	Selects the screen for setting maintenance items to be managed periodically.
(23)	M-INFO	Selects the screen for displaying information about maintenance performed.
(24)	W.DGNS	Selects the screen for displaying data such as servo positional deviation values, torque values, machine signals, and so forth as graphs.
(26)	TOUCH PANEL	Selects the screen for setting a touch panel.
(27)	FSSB	Selects the screen for making settings related to the high-speed serial servo bus (FSSB: FANUC Serial Servo Bus).
(28)	PRMTUN	Selects the screen for setting parameters necessary for start-up and tuning.

No.	Chapter menu	Description
(31)	EMBED PORT	Selects the screen for making settings related to the embedded Ethernet (embedded port).
(32)	PCMCIA LAN	Selects the screen for making settings related to the embedded Ethernet (PCMCIA Ethernet card).
(33)	ETHNET BOARD	Selects the screen for making settings related to the fast Ethernet/fast data server.
(34)	PROFI MASTER	Selects the screen for making settings related to the profibus master function.
(37)	M CODE	Selects the screen for setting an M code group.
(41)	PROFI SLAVE	Selects the screen for making settings related to the profi-bus slave function.
(42)	DEVNETMASTER	Selects the screen for making settings related to the DeviceNet master function.
(46)	DUAL CHECK	Selects the screen for making settings related to the dual check safety function.
(47)	R.TIME MACRO	Selects the screen for making settings related to the real-time custom macro function.

**Message screen**

The chapter selection soft keys that belong to the function key  and the function of each screen are described below.

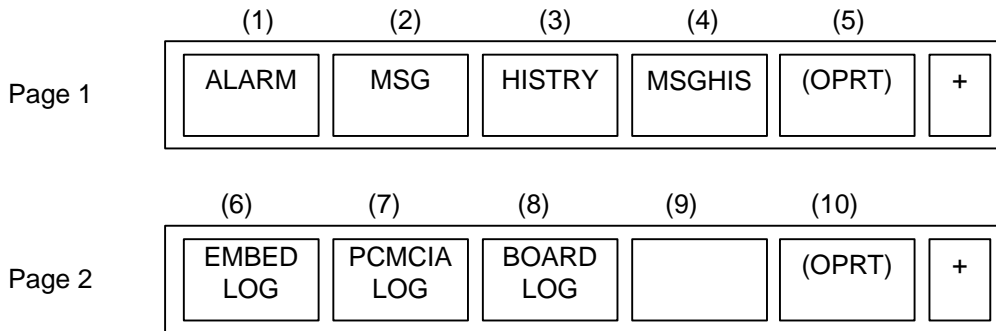

**Table 1.1.4 (e) Message**

No.	Chapter menu	Description
(1)	ALARM	Selects the alarm message screen.
(2)	MSG	Selects the operator message screen.
(3)	HISTRY	Selects the screen for displaying the details of alarms issued so far.
(4)	MSGHIS	Selects the external operator message screen.
(6)	EMBED LOG	Selects the screen for displaying error messages related to the embedded Ethernet (embedded port).
(7)	PCMCIA LOG	Selects the screen for displaying error messages related to the embedded Ethernet (PCMCIA Ethernet card).
(8)	BOARD LOG	Selects the screen for displaying error messages related to the fast Ethernet/fast data server.

**Graphic screen**

The chapter selection soft keys that belong to the function key  and the function of each screen are described below.

When the graphic display function is enabled:

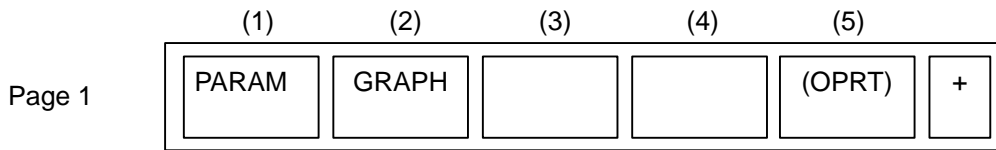

Table 1.1.4 (f) Graphic

No.	Chapter menu	Description
(1)	PARAM	Selects the screen for setting graphic parameters.
(2)	GRAPH	Selects the screen for graphically displaying the tool path.

When the dynamic graphic display function is enabled:

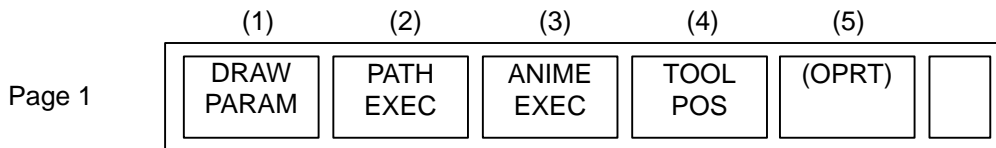





Table 1.1.4 (g) Graphic



No.	Chapter menu	Description
(1)	DRAW PARAM	Selects the screen for setting drawing parameters.
(2)	PATH EXEC	Selects the screen for drawing tool paths.
(3)	ANIME EXEC	Selects the screen for drawing animation.
(4)	TOOL POS	Selects the screen for displaying tool positions.

## 1.2 SYSTEM CONFIGURATION SCREEN

After the system has started normally, you can find the types of installed printed circuit boards and software types by displaying a system configuration screen.

### 1.2.1 Display Method

- 1 Press function key .
- 2 Press soft key [SYSTEM].
- 3 Two types of system configuration screen, the hardware screen and software screen, are provided, and you can switch between these screens by using the   page keys.

When all information cannot be displayed on one page of the screen, you can switch to the next page by using the   keys.

## 1.2.2 Hardware Configuration Screen

- Screen display

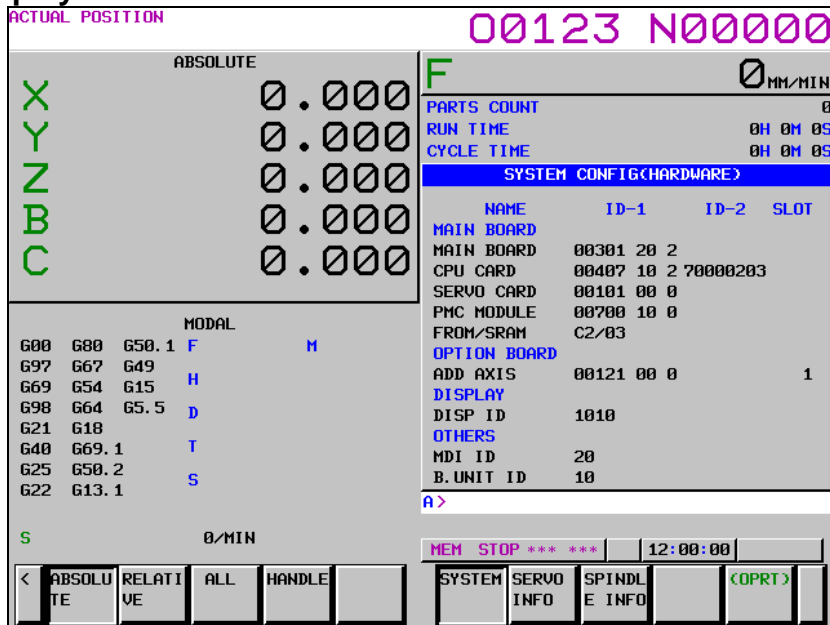

- Displayed information

The following explains the displayed information:

1. NAME
  - MAIN BOARD
    - Displays information on the main board, and cards and modules on the main board.
  - OPTION BOARD
    - Displays information on the board installed in the option slot.
  - DISPLAY
    - Displays information on the display unit.
  - OTHERS
    - Displays information on other components (such as an MDI and a basic unit).
2. SLOT
  - Displays the number of the slot in which the option board is inserted.

## 1.2.3 Software Configuration Screen

### - Screen display

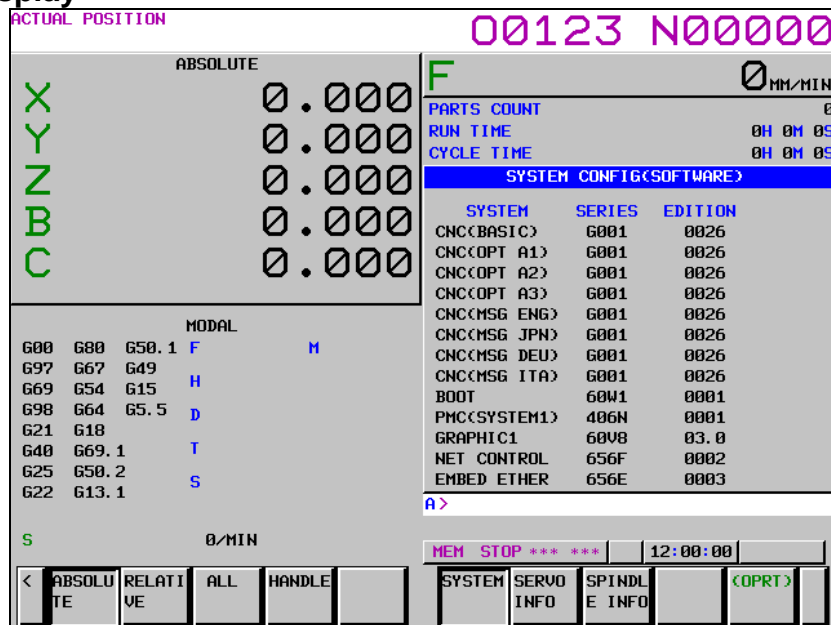

### - Displayed information

The following explains the displayed information:

- SYSTEM : Software type
- SERIES : Software series
- EDITION : Software edition

### - Displayed systems and corresponding software types

The following lists the correspondence between displayed systems and software:

System	Software type
CNC(BASIC)	CNC basic software
CNC(OPT A1)	Option assembly A1
CNC(OPT A2)	Option assembly A2
CNC(OPT A3)	Option assembly A3
CNC(MSG ENG)	Language indication (English)
CNC(MSG JPN)	Language indication (Japanese)
CNC(MSG DEU)	Language indication (German)
CNC(MSG FRA)	Language indication (French)
CNC(MSG CHT)	Language indication (Chinese (traditional characters))
CNC(MSG ITA)	Language indication (Italian)
CNC(MSG KOR)	Language indication (Korean)
CNC(MSG ESP)	Language indication (Spanish)
CNC(MSG NLD)	Language indication (Dutch)
CNC(MSG DAN)	Language indication (Danish)
CNC(MSG PTG)	Language indication (Portuguese)
CNC(MSG PLK)	Language indication (Polish)
CNC(MSG HUN)	Language indication (Hungarian)
CNC(MSG SVE)	Language indication (Swedish)
CNC(MSG CSY)	Language indication (Czech)
CNC(MSG CHS)	Language indication (Chinese (simplified characters))
CNC(MSG RUS)	Language indication (Russian)
CNC(MSG TRK)	Language indication (Turkish)

System	Software type
BOOT	Boot system
PMC(SYSTEM)	PMC function
PMC(LADDER1)	PMC ladder for path 1
PMC(LADDER2)	PMC ladder for path 2
PMC(LADDER3)	PMC ladder for path 3
PMC(LAD DCS)	Dual check safety PMC ladder
CLB(SYSTEM)	System software for C language board
CLB(USER)	User software for C language board
SERVO	Digital servo software (up to ten programs displayed)
SPINDLE-1	Spindle 1
SPINDLE-2	Spindle 2
SPINDLE-3	Spindle 3
SPINDLE-4	Spindle 4
SPINDLE-5	Spindle 5
SPINDLE-6	Spindle 6
SPINDLE-7	Spindle 7
SPINDLE-8	Spindle 8
SPINDLE-9	Spindle 9
SPINDLE-10	Spindle 10
SPINDLE-11	Spindle 11
SPINDLE-12	Spindle 12
SPINDLE-13	Spindle 13
SPINDLE-14	Spindle 14
SPINDLE-15	Spindle 15
SPINDLE-16	Spindle 16
GRAPHIC	Graphic function
GRAPHIC1	Graphic function
GRAPHIC2	Graphic function
MACRO EXE1	Macro executor 1
MACRO EXE2	Macro executor 2
MACRO EXE3	Macro executor 3
MACRO EXE4	Macro executor 4
MACRO EXE5	Macro executor 5
MACRO EXE6	Macro executor 6
MACRO EXE7	Macro executor 7
MACRO EXE8	Macro executor 8
MACRO EXE9	Macro executor 9
MACRO EXE10	Macro executor 10
MACRO EXE11	Macro executor 11
MACRO EXE12	Macro executor 12
MACRO EXE13	Macro executor 13
MACRO EXE14	Macro executor 14
MACRO EXE15	Macro executor 15
MACRO EXE16	Macro executor 16
MACRO EXE17	Macro executor 17
MACRO EXE18	Macro executor 18
MACRO EXE19	Macro executor 19
MACRO EXE20	Macro executor 20
CEXELIB	Library for C Language Executor
CEXEAPL	Application for C Language Executor
MGI(LIB)	Library for MANUAL GUIDE i
MGI(SYSTEM)	System software for MANUAL GUIDE i
MGI(MACRO M)	Macro software for MANUAL GUIDE i (M series)
MGI(MACRO T)	Macro software for MANUAL GUIDE i (T series)

System	Software type
EMBED ETHER	Control software for embedded Ethernet function
PROFI SOFT	Software for PROFIBUS function
PROFI MASTER	Control software for PROFIBUS master function
PROFI SLAVE	Control software for PROFIBUS slave function
DEVNT SOFT	Software for DeviceNet function
DEVNT MASTER	Control software for DeviceNet master function
DEVNT SLAVE	Control software for DeviceNet slave function
ETHERNET	Control software for fast Data Server
CMB(SYSTEM)	Customers' board system software
CMB(USER)	Customers' board user software
USB SOFT	Control software for USB function

- Display of macro executor  
The series and edition are displayed for each number specified at the time of P-CODE macro creation.  
Up to 20 types of macro executor are displayed.

## 1.2.4 Outputting System Configuration Data

Data displayed on the system configuration screen can be output to an input/output device.

- (1) Press function key .
- (2) Press the EDIT switch on the machine operator's panel.
- (3) Press soft key [SYSTEM] to display the system configuration screen.
- (4) Press soft key [(OPRT)] and select soft key [PUNCH].
- (5) Press soft key [EXCE].
- (6) Data is output to the output device selected by parameter No. 20.

Data is output to a file named SYS\_CONF.TXT.

## 1.3 DIAGNOSIS FUNCTION

### 1.3.1 Displaying Diagnosis Screen

- (1) Press function key .
- (2) Press soft key [DGNOS], then a diagnosis screen is displayed.

### 1.3.2 Contents Displayed

#### Causes when the machine does not travel in spite of giving a command

Diagnosis	0	CNC internal state 1
[Data type] Bit		
NAME		Internal state when "1" is displayed
INPOSITION CHECK		In-position check is being done.
FEEDRATE OVERRIDE 0%		Feedrate override is 0%.
JOG FEED OVERRIDE 0%		Jog feedrate override is 0%.
INTER/START LOCK ON		Interlock/start lock is on.
SPEED ARRIVAL ON		The system is waiting for the speed arrival signal to turn on.

WAIT REVOLUTION	The system is waiting for the spindle one-rotation signal in threading.
STOP POSITION OCDER	The system is waiting for the rotation of the position coder in spindle feed per revolution.
FEED STOP	A feed stop was made.

Diagnosis    
When a dwell is being executed, "1" is displayed.

Diagnosis    
[Data type] Bit  
NAME Internal state when "1" is displayed  
FOREGROUND READING Data is being input in the foreground.  
BACKGROUND READING Data is being input in the background.

### Reader/puncher interface output state

Diagnosis    
When data is being output through the reader/puncher interface, "1" is indicated.

### State of TH alarm

Diagnosis    
[Data type] 2-word axis  
The position where the TH alarm occurred in foreground input is indicated by the number of characters from the beginning of the block.

Diagnosis    
[Data type] 2-word axis  
The character code of the character at which the TH alarm occurred in foreground input is indicated.

Diagnosis    
[Data type] 2-word axis  
The position where the TH alarm occurred in background input is indicated by the number of characters from the beginning of the block.

Diagnosis    
[Data type] 2-word axis  
The character code of the character at which the TH alarm occurred in background input is indicated.

### Display language of the CNC screen

Diagnosis    
[Data type] Byte

The number of the current display language of the CNC screen is indicated.  
The correspondence between languages and numbers is show below.

0	:	English
1	:	Japanese
2	:	German
3	:	French
4	:	Chinese (traditional characters)
5	:	Italian
6	:	Korean
7	:	Spanish
8	:	Dutch



- 9 : Danish
- 10 : Portuguese
- 11 : Polish
- 12 : Hungarian
- 13 : Swedish
- 14 : Czech
- 15 : Chinese (simplified characters)
- 16 : Russian
- 17 : Turkish

**Details of serial Pulsecoder**

		#7	#6	#5	#4	#3	#2	#1	#0
Diagnosis	200	OVL	LV	OVC	HCA	HVA	DCA	FBA	OFA

- #0 **OFA** Overflow alarm
- #1 **FBA** Disconnection alarm
- #2 **DCA** Discharge alarm
- #3 **HVA** Overvoltage alarm
- #4 **HCA** Abnormal current alarm
- #5 **OVC** Over current alarm
- #6 **LV** Insufficient voltage alarm
- #7 **OVL** Overload alarm

		#7	#6	#5	#4	#3	#2	#1	#0
Diagnosis	201	ALD	PCR		EXP				

- #4 **EXP**
- #7 **ALD**

	ALD	EXP	Description
Overload alarm	0	-	Motor overheat
	1	-	Amplifier overheat
Disconnection alarm	1	0	Built-in Pulsecoder (hard)
	1	1	Disconnection of separated type Pulsecoder (hard)
	0	0	Disconnection of Pulsecoder (software)

- #6 **PCR** The one-rotation signal of the position detector was caught before a manual reference position return is performed. Since the manual reference position return grid was established, a manual reference position return is enabled.

**NOTE**  
 This bit is valid only when the operation of the manual reference position return mode is started.

		#7	#6	#5	#4	#3	#2	#1	#0
Diagnosis	202		CSA	BLA	PHA	RCA	BZA	CKA	SPH

- #0 **SPH** Serial Pulsecoder or feedback cable is faulty.  
 Counting of feedback cable is erroneous.
- #1 **CKA** Serial Pulsecoder is faulty.  
 Internal block stopped.
- #2 **BZA** Battery voltage became 0.  
 Replace the battery and set the reference position.
- #3 **RCA** Serial Pulsecoder is faulty.  
 The speed was incorrectly counted.
- #4 **PHA** Serial Pulsecoder or feedback cable is erroneous.  
 Counting of feedback cable is erroneous.
- #5 **BLA** Battery voltage is low (warning)
- #6 **CSA** Hardware of serial Pulsecoder is abnormal

		#7	#6	#5	#4	#3	#2	#1	#0
Diagnosis	203	DTE	CRC	STB	PRM				

#4 **PRM** A parameter failure was detected on the digital servo side. See the cause and measure described in diagnosis No. 352.

#5 **STB** Communication failure of serial Pulsecoder.  
Transferred data is erroneous.

#6 **CRC** Communication failure of serial Pulsecoder.  
Transferred data is erroneous.

#7 **DTE** Communication failure of serial Pulsecoder.  
There is no response for communication.

		#7	#6	#5	#4	#3	#2	#1	#0
Diagnosis	204		OFS	MCC	LDA	PMS			

#3 **PMS** Feedback is not correct due to faulty serial Pulsecoder C or feedback cable.

#4 **LDA** Serial Pulsecoder LED is abnormal

#5 **MCC** Contacts of MCC of servo amplifier is melted.

#6 **OFS** Abnormal current value result of A/D conversion of digital servo

### Details of separate serial Pulsecoder alarms

		#7	#6	#5	#4	#3	#2	#1	#0
Diagnosis	205	OHA	LDA	BLA	PHA	CMA	BZA	PMA	SPH

#0 **SPH** A soft phase data error occurred in the separate Pulsecoder.

#1 **PMA** A pulse error occurred in the separate Pulsecoder.

#2 **BZA** The battery voltage for the separate Pulsecoder is zero.

#3 **CMA** A count error occurred in the separate Pulsecoder.

#4 **PHA** A phase data error occurred in the separate linear scale.

#5 **BLA** A low battery voltage occurred in the separate Pulsecoder.

#6 **LDA** An LED error occurred in the separate Pulsecoder.

#7 **OHA** Overheat occurred in the separate Pulsecoder.

		#7	#6	#5	#4	#3	#2	#1	#0
Diagnosis	206	DTE	CRC	STB					

#5 **STB** A stop bit error occurred in the separate Pulsecoder.

#6 **CRC** A CRC error occurred in the separate Pulsecoder.

#7 **DTE** A data error occurred in the separate Pulsecoder.

### Details of invalid servo parameter alarms (on the CNC side)

When servo alarm No. 417 is issued, and diagnosis No. 203#4 = 0, its cause is indicated.

When diagnosis No. 203#4 = 1, see diagnosis No. 352.

		#7	#6	#5	#4	#3	#2	#1	#0
Diagnosis	280				DIR	PLS	PLC		MOT

#0 **MOT** The motor type specified in parameter No. 2020 falls outside the predetermined range.

#2 **PLC** The number of velocity feedback pulses per motor revolution, specified in parameter No. 2023, is zero or less. The value is invalid.

#3 **PLS** The number of position feedback pulses per motor revolution, specified in parameter No. 2024, is zero or less. The value is invalid.

#4 **DIR** The wrong direction of rotation for the motor is specified in parameter No. 2022 (the value is other than 111 or -111).

		#7	#6	#5	#4	#3	#2	#1	#0
Diagnosis	281								TDM

#0 **TDM** Four-winding motor drive (bit 7 of parameter No. 2211) or two-winding motor drive (bit 6 of parameter No. 2211) is enabled when no option for tandem control is present.

**Position error amount**

Diagnosis

$$\text{Position error} = \frac{\text{Feed rate [mm/min]} \times 100}{60 \times \text{servo loop gain [1/sec]}} \times \frac{1}{\text{Detection unit}}$$

**Machine position**

Diagnosis

**Distance from the end of the deceleration dog to the first grid point**

Diagnosis

[Data type] Real axis

[Unit of data] Machine unit

[Valid data range] 0 to ±99999999

**NOTE**

For the reference position setting without a dog, the distance from the beginning of the reference position setting without a dog to the first grid point is assumed.

**Reference counter**

Diagnosis

[Data type] 2-word axis

[Unit of data] Detection unit

[Valid data range] -99999999 to 99999999

**Motor temperature information**

Diagnosis

[Data type] Byte axis

[Unit of data] °C

[Valid data range] 0 to 255

The temperature of the coil of the servo motor is indicated. When the temperature reaches 140°C, a motor overheat alarm is issued.

Diagnosis

[Data type] Byte axis

[Unit of data] °C

[Valid data range] 0 to 255

The temperature of the printed circuit board in the Pulsecoder is indicated. When the temperature reaches 100°C (approximately 85°C for the temperature of atmosphere in the Pulsecoder), a motor overheat alarm is issued.

**NOTE**

1 Temperature information has the following error:

- 50°C to 160°C ±5°C
- 160°C to 180°C ±10°C

2 The temperature at which an overheat alarm is issued has an error of up to 5°C.

### Cause that sets bit 4 (APZ) of parameter No. 1815 to 0

You can find the cause that sets bit 4 (APZ) of parameter No. 1815 to 0 by checking diagnosis Nos. 310 and 311.

Once diagnosis No. 310 or 311 is set to 1, this setting is kept unchanged until the zero point of the absolute position detector of the corresponding axis is set again. Possible causes that set APZ to 0 are as follows:

	#7	#6	#5	#4	#3	#2	#1	#0	
Diagnosis	310		DTH	ALP		BZ2	BZ1	PR2	PR1
#0	<b>PR1</b> One of the following parameters was changed: No.1815#0, No.1815#1, No.1815#6, No.1817#3, No.1820, No.1821, No.1822, No.1823, No.1850, No.1868, No.1869, No.1874, No.1875, No.1876, No.1883, No.1884, No.2022, No.2084, No.2085, No.2179								
#1	<b>PR2</b> Bit 1 (ATS) of parameter No. 8303 was changed. Alternatively, when bit 7 (SMA) of parameter No. 8302 was set to 1, APZ of the axis to be synchronized together was set to 0.								
#2	<b>BZ1</b> A battery voltage of 0 V was detected. (Inductosyn)								
#3	<b>BZ2</b> A battery voltage of 0 V was detected. (Separate position detector)								
#5	<b>ALP</b> The zero point was set by MDI when the $\alpha$ pulse coder had not rotate one or more turns. Alternatively, the CNC could not obtain a correct value from the absolute pulse coder.								
#6	<b>DTH</b> An axis detach operation was performed by the controlled-axis detach signal DTCH <G124> or by setting bit 7 (RMV) of parameter No. 0012.								

	#7	#6	#5	#4	#3	#2	#1	#0	
Diagnosis	311		DUA	XBZ	GSG	AL4	AL3	AL2	AL1
#0	<b>AL1</b> An SV alarm (SV301 to SV305) was issued.								
#1	<b>AL2</b> When bit 1 (CRF) of parameter No. 1819 was set to 1, alarm SV0445, "SOFT DISCONNECT ALARM", SV0447, "HARD DISCONNECT(EXT)", or SV0646, "ABNORMAL ANALOG SIGNAL(EXT)", was detected.								
#2	<b>AL3</b> A battery voltage of 0 V was detected. (Built-in serial Pulsecoder)								
#3	<b>AL4</b> Alarm SV0367, "COUNT MISS(INT)", was detected.								
#4	<b>GSG</b> The status of broken-wire alarm ignore signal NDCAL (G202) changed from 1 to 0.								
#5	<b>XBZ</b> A battery voltage of 0 V or alarm SV0382, "COUNT MISS(EXT)", was detected. (Separate serial position detector)								
#6	<b>DUA</b> When bit 1 (CRF) of parameter No. 1819 was set to 1, alarm SV0421, "EXCESS ERROR(SEMI-FULL)", was detected.								

### Details of invalid servo parameter setting alarms (on the servo side)

Diagnosis	352	Detail number for invalid servo parameter setting alarm
Indicates information that can be used to identify the location (parameter) and cause of an invalid servo parameter setting alarm (servo alarm No. 417).		
This diagnosis information is valid when the following conditions are satisfied.		
<ul style="list-style-type: none"> <li>Servo alarm No. 417 has occurred.</li> <li>Bit 4 of diagnosis No. 203 (PRM) = 1</li> </ul>		
See the following table for the displayed detail numbers and the corresponding causes. For further detail information that could be used to take measures, refer to FANUC AC Servo Motor $\alpha$ s/ $\alpha$ i/ $\beta$ is series Parameter Manual (B-65270EN).		

#### • Detailed descriptions about invalid servo parameter setting alarms

Detail number	Parameter No.	Cause	Action
83	2019	Parameter settings related to learning control are illegal → See Supplementary.	Change the parameter settings so that they fall in the applicable range.

Detail number	Parameter No.	Cause	Action
0233	2023	When initialization bit 0 is set to 1, the number of velocity pulses exceeds 13100.	Correct the number of velocity pulses so that it is within 13100.
0234	2023	When a DD motor is used, a value smaller than 512 is set as the number of velocity pulses.	Set 512 or a greater number as the number of velocity pulses, or disable the DD motor. Bit 0 of parameter No. 2300=0
0243	2024	When initialization bit 0 is set to 1, the number of position pulses exceeds 13100.	Correct the number of position pulses so that it is within 13100. Use the position feedback pulse conversion coefficient (parameter No. 2185).
0434 0435	2043	The internal value of the velocity loop integral gain overflowed.	Decrease the value of the velocity loop integral gain parameter.
0443 0444 0445	2044	The internal value of the velocity loop proportional gain overflowed.	Use the function for changing the internal format of the velocity loop proportional gain (bit 6 of parameter No. 2200). Alternatively, decrease the parameter setting.
0474 0475	2047	The internal value of the observer parameter (POA1) overflowed.	Correct the setting to $(-1) \times (\text{desired value})/10$ .
0534 0535	2053	The internal value of a parameter related to dead zone compensation overflowed.	Decrease the setting to the extent that the illegal servo parameter setting alarm is not caused.
0544 0545	2054	The internal value of a parameter related to dead zone compensation overflowed.	Decrease the setting to the extent that the illegal servo parameter setting alarm is not caused.
0694 0695 0696 0699	2069	The internal value of the velocity feed-forward coefficient overflowed.	Decrease the velocity feed-forward coefficient.
0754 0755	2075	The setting for this parameter has overflowed.	This parameter is not used at present. Set 0.
0764 0765	2076	The setting for this parameter has overflowed.	This parameter is not used at present. Set 0.
0843	2084	A positive value is not set as the flexible feed gear numerator. Alternatively, the following condition exists: Feed gear numerator > denominator $\times$ 16	Set a positive value as the flexible feed gear numerator. Alternatively, satisfy the following condition: Feed gear numerator $\leq$ denominator $\times$ 16 (except for phase A-/B-specific separate detector).
0853	2085	A positive value is not set as the flexible feed gear denominator.	Set a positive value as the flexible feed gear denominator.
0883	2088	For an axis with a serial type separate detector, a value exceeding 100 is set as the machine velocity feedback coefficient.	For an axis with a serial type separate detector, the upper limit of the machine velocity feedback coefficient is 100. Correct the coefficient so that it does not exceed 100.
0884 0885 0886	2088	The internal value of the machine velocity feedback coefficient overflowed.	Decrease the machine velocity feedback coefficient. Alternatively, use the vibration-damping control function that has an equivalent effect.

Detail number	Parameter No.	Cause	Action
0994 0995 0996	2099	The internal value for N pulse suppression overflowed.	Disable the N pulse suppression function. Alternatively, decrease the parameter setting so that no overflow will occur.
1033	2103	The retract distance related to an abnormal load differs between the L and M axes (if the same-axis retract function is in use).	Set the same value for both the L and M axes.
1123	2112	Although a linear motor is used, the AMR conversion coefficient parameter is not input.	Set the AMR conversion coefficient.
1182	2118 2078 2079	The dual position feedback conversion coefficient has not been specified.	Specify the dual position feedback conversion coefficient.
1284 1285	2128	When a small value is set as the number of velocity pulses, the internal value of a parameter related to current control overflows.	Decrease the value in this parameter to the extent that the alarm is not caused.
1294 1295	2129	When a large value is set as the number of velocity pulses, the internal value of a parameter related to current control overflows.	When the value set in this parameter is resolved to the form $a \times 256 + b$ , set a smaller value in a again.
1393	2139	The AMR offset setting value of a linear motor exceeds $\pm 45$ .	Enlarge the AMR offset setting range (bit 0 of parameter N. 2270=1) to input a value within a range of $\pm 60$ .
1454 1455 1456 1459	2145	Velocity feed-forward coefficient for cutting overflowed.	Decrease the velocity feed-forward coefficient.
1493	2149	A value greater than 6 is specified in this parameter.	Only 6 or less can be specified in this parameter. Change the setting to 6 or below 6.
1503	2150	A value equal to or greater than 10 is set.	Set a value less than 10.
1786	2178	Bit 6 of No. 2212 or bit 6 of No. 2213 is set to 1, and No. 2621=0 is set.	Set bit 6 of No. 2212 or bit 6 of No. 2213 to 0.
1793	2179	A negative value or a value greater than the setting of parameter No. 1821 is set.	Set a positive value less than the setting of parameter No. 1821.
1853	2185	A negative value or a value greater than the setting of parameter No. 2023 is set.	Set a positive value less than the setting of parameter No. 2023.
2203	2220#0	If pole detection is enabled (bit 7 of No. 2213=1) and a non-binary detector is enabled (bit 0 of No. 2220=1), an illegal servo parameter setting alarm is issued when any of the following is set: - AMR conversion coefficient 1 $\leq$ 0 - AMR conversion coefficient 2 $\leq$ 0 - AMR conversion coefficient 2 $>$ 512 (The settable range is 1 (2 poles) to 512 (1024 poles).)	Set the AMR conversion coefficients correctly.
2243	2224#5	This alarm is issued when a setting is made to neglect the invalid setting of the parameter for the feed-forward timing adjustment function (bit 5 of No. 2224=1) and a command for nano interpolation is issued.	Use either one.

Detail number	Parameter No.	Cause	Action
2632	2263	When the lifting function against gravity is enabled (bit 7 of No. 2298=1) or the post-servo-off travel distance monitor function is enabled (bit 5 of No. 2278=1), the function for enabling the CNC software to post the detection unit to the servo software is not supported and the setting of the detection unit (No. 2263) is disabled.	Take one of the following actions: 1) Set a value in parameter No. 2263. 2) Disable the lifting function against gravity and the post-servo-off travel distance monitor function. 3) Use CNC software that supports the function for enabling the detection unit to be posted to the servo software.
2780	2277#5,6,7 2278#0,2,4 24096	When the first SDU unit is not used (No.24096=0), a setting is made to connect a detector (acceleration sensor, temperature detection circuit, or analog check interface unit) to the first SDU unit.	Check the FSSB setting (No.24096) or the detector setting (bits 0, 2, and 4 of No. 2278).
2781	2277#5,6,7 2278#1,3,4 24097	When the second SDU unit is not used (No.24097=0), a setting is made to connect a detector (acceleration sensor, temperature detection circuit, or analog check interface unit) to the second SDU unit.	Check the FSSB setting (No.24097) or the detector setting (bits 1, 3, and 4 of No. 2278).
2782	2277#5,6,7 2278#0,4 24096	Any of the following settings is made: • For use with the first SDU unit, both of an acceleration sensor and temperature detection circuit are enabled. • Settings are made to use the first SDU unit (No.24096>0), disable an acceleration sensor (bits 5, 6, 7 of No. 2277=0,0,0), and read acceleration data from the second unit (bit 1 of No. 2278=1).	Check the settings of the acceleration sensor and temperature detection circuit.
2783	2277#5,6,7 2278#1,4 24097	Any of the following settings is made: • For use with the second SDU unit, both of an acceleration sensor and temperature detection circuit are enabled. • Settings are made to use the second SDU unit (No.24097>0), disable an acceleration sensor (bits 5, 6, 7 of No. 2277=0,0,0), and read acceleration data from the second unit (bit 1 of No. 2278=1).	Check the settings of the acceleration sensor and temperature detection circuit.
2784	1815#1 2277#5,6,7 2278#0,1,4	At the time of full-closed system setting, a detector other than a separate position detector is connected (with the first/second SDU unit).	Modify the setting of the detector.
2785	1815#1 2277#5,6,7 2278#0,4	At the time of full-closed system setting, a detector other than a separate position detector is connected (with the first SDU unit).	Modify the setting of the detector.
2786	1815#1 2277#5,6,7 2278#1,4	At the time of full-closed system setting, a detector other than a separate position detector is connected (with the second SDU unit).	Modify the setting of the detector.

Detail number	Parameter No.	Cause	Action
2787	2278#0,#1	A setting is made to connect two temperature detection circuits.	Only one temperature detection circuit can be connected. Modify the setting so that data is read from one of the first and second SDU units.
2788	1815#1 2277#5,6,7 2278#4 2278#0,1 24096 24097	A setting is made to connect two temperature detection circuits.	Only one temperature detection circuit can be connected. Modify the setting so that data is read from one of the first and second SDU units.
3002	2300#3,#7	The $\alpha i$ CZ detection circuit and linear motor position detection circuit do not support overheat signal connection.	Replace the $\alpha i$ CZ detection circuit and linear motor position detection circuit with those circuits that support overheat signal connection. Alternatively, modify the setting so that the overheat signal is read from a DI signal (bit 3 of parameter No. 2300=0).
3012	2301#2,#7	<ul style="list-style-type: none"> <li>When bit 2 of No. 2301=1 Hardware (PS, SV) that does not support DC link voltage information output is connected, but bit 2 of No. 2301 is set to 1.</li> <li>When bit 7 of No. 2301=1 The CNC software does not support the torque control setting range extension function.</li> </ul>	<ul style="list-style-type: none"> <li>When bit 2 of No. 2301=1 Set bit 2 of No. 2301 to 0.</li> <li>When bit 7 of No. 2301=1 Use CNC software that supports the function.</li> </ul>
3553 3603	2355	The value 4 or a smaller number is set.	Set the value 5 or a greater number.
3603	2113 2360 2363 2366	The value 95 or smaller number is set.	Set the value 96 or a greater number. Alternatively, if no resonance elimination filter is used, set all of the center frequency, band width, and dumping value to 0.
3603 3663	2366	The value 4 or a smaller number is set.	Set the value 5 or a greater number.
4553	2455	A negative value is set.	Set the value 0 or a greater number.
4563	2456	A value not within 0 to 12 is set.	Set a value within 0 to 12.
8213	1821	A positive value is not set in the reference counter capacity parameter.	Set a positive value in this parameter.
8254 8255 8256	1825	A position gain of 0 is set, or the internal position gain value has overflowed.	<ul style="list-style-type: none"> <li>Set a value other than 0 (when setting = 0).</li> <li>Use the function for automatic format change for position gain setting range. (Set bit 6 of parameter No. 2209 to 1.)</li> </ul>
9053	1815#1 24096 24097	At the time of full-closed system setting, no separate detector interface unit is set.	Set a separate detector interface unit.
10010 10016 10019	2200#0	The internal value of a parameter used to detect runaway has overflowed.	Do not use the runaway detection function (specify bit 0 = 1).
10033	2004	Illegal control cycle setting This error occurs if automatic modification is carried out for the control cycle.	Correct this parameter related to interrupt cycle setting.
10053	2018#0	When a linear motor is used, the scale reverse connection bit is set.	When the linear motor is used, the scale reverse connection bit cannot be used.



Detail number	Parameter No.	Cause	Action
10062	2209#4	The amplifier used does not support the HC alarm prevention function.	When you use the current amplifier continuously, set the function bit shown to the left to 0. When using the HC alarm prevention function, use an appropriate amplifier that supports the function.
10092 10093	2004 2013#0 2014#0	Different control cycles are set within one servo CPU.	Set the same control cycle for axes controlled by one servo CPU.
		When HRV4 is enabled, a detector that does not support HRV4 is used.	Replace the detector with a detector supporting HRV4. Alternatively, disable HRV4.
		When HRV4 is enabled, a servo amplifier that does not support HRV4 is connected.	Replace the servo amplifier with a servo amplifier supporting HRV4. Alternatively, disable HRV4.
10103	2004 2013#0	HRV1 is set.	The Series 30i does not allow HRV1 setting. Set HRV2, HRV3 or HRV4.
10113	2013#0	Current cycle mismatch alarm. This alarm is issued if the specified current cycle does not match the actual setting.	An axis for which HRV3 is specified exists on the same optical cable. Review the placement of the amplifier, or disable HRV3.
10123	2013#0	Alarm for indicating the disability of HRV3 setting. This alarm is issued when the axis supports HRV3 but the other axis of the pair does not support HRV3.	Eliminate the cause of the disability in setting the other axis. Alternatively, cancel the HRV3 setting.
10133	2013#0 2014#0	When HRV4 is set, this alarm is issued if any of the following conditions is met. <ul style="list-style-type: none"> <li>Servo software not supporting HRV4 is used.</li> <li>The same FSSB system includes axes with HRV4 setting and axes with HRV2 or HRV3 setting.</li> <li>The limitation in the number of axes is not observed. (In HRV4 control, one axis/DSP is set.)</li> </ul>	Eliminate the causes listed on the left. Alternatively, cancel the HRV4 setting.
10133	2013#0 2014#0	This alarm is issued when HRV3 or HRV4 is set, but the amplifier does not support these control types.	HRV3 or HRV4 is unusable for the axis on which the alarm was issued.
10202	2277#5,6,7 2278#0,2,4	The ID of the detector connected to the first SDU unit differs from the parameter setting.	Check the detector-related parameter or the state of detector connection.
10212	2277#5,6,7 2278#1,3,4	The ID of the detector connected to the second SDU unit differs from the parameter setting.	Check the detector-related parameter or the state of detector connection.

Supplementary: Details of an illegal learning control parameter

Set parameter No. 2115 to 0, and parameter No. 2151 to 6265 to change the value of DGN No. 353 to a binary number. You can find a detailed cause from the bit position of the obtained binary number at which 1 is set.

Position	Cause
B3	The band-pass filter (No. 2512) is not in the range.

Position	Cause
B4	The profile number (No. 2511) is not in the range.
B5	The specified data period (No. 251, 2519, 2521, 2523, or 2525) is not in the range.
B6	The total number of profiles (No. 2510) is not in the range.
B7	This alarm is issued when G05 starts during a memory clear operation.
B8	This alarm is issued when the total number of profiles (No. 2510) is not 0, and the profile number (No. 2511) is 0.
B9	This alarm is issued when the automatically-set thinning shift value exceeds the range because the specified data period is too long.

Diagnosis

Diagnosis

Diagnosis

The number of times a communication error occurred during serial communication with the detector is indicated.

Data transmitted during communication is guaranteed unless another alarm occurs. However, if the counter value indicated in this diagnosis information increases in a short period, there is a high probability that serial communication is disturbed by noise. So, take sufficient measures to prevent noise.

\* For details, refer to a relevant manual on FANUC SERVO MOTOR *ai* series.

Diagnosis

This information is provided to analyze the cause of the V ready-off alarm (servo alarm SV0401).

Convert the indicated value to a binary representation, and check bits 5 to 14 of the binary representation.

When amplifier excitation is turned on, these bits are set to 1 sequentially from the lowest bit, which is bit 5. If the amplifier is activated normally, bits 5 to 14 are all set to 1.

Therefore, check the bits sequentially from the lowest bit to find the first bit that is set to 0. This bit indicates that the corresponding processing could not be completed and so the V ready-off alarm was caused.

#15	#14	#13	#12	#11	#10	#09	#08
	SRDY	DRDY	INTL		CRDY		

#07	#06	#05	#04	#03	#02	#01	#00
	*ESP						

- # 06            \*ESP    Converter emergency stop state released
- # 10            CRDY    Converter ready
- # 12            INTL    DB relay released
- # 13            DRDY    Amplifier ready (amplifier)
- # 14            SRDY    Amplifier ready (software)

\* For details, refer to a relevant manual on FANUC SERVO MOTOR *ai* series.

Diagnosis

The diagnosis information is the same as that of diagnosis No. 355. See the descriptions in diagnoses No.355 to 357.

Diagnosis 360 Cumulative value of specified pulses (NC)

[Data type] 2-word

[Unit of data] Detection unit

[Valid data range] -99999999 to 99999999

Cumulative value of move commands distributed from the CNC since power-on is indicated.

Diagnosis 361 Compensation pulses (NC)

[Data type] 2-word

[Unit of data] Detection unit

[Valid data range] -99999999 to 99999999

Cumulative value of compensation pulses (backlash compensation, pitch error compensation, and so on) distributed from the CNC since power-on is indicated.

Diagnosis 362 Cumulative value of specified pulses (SV)

[Data type] 2-word

[Unit of data] Detection unit

[Valid data range] -99999999 to 99999999

Cumulative value of move pulses and compensation pulses received by the servo system since power-on is indicated.

Diagnosis 363 Cumulative feedback (SV)

[Data type] 2-word

[Unit of data] Detection unit

[Valid data range] -99999999 to 99999999

Cumulative value of positional feedback pulses the servo system received from the pulse coder since power-on is indicated.

### Diagnosis data related to the Inductosyn absolute position detector

Diagnosis 380 Difference between the absolute position of the motor and offset data

[Data type] 2-word axis

[Unit of data] Detection unit

$$\frac{M \text{ (absolute position of the motor)} - S \text{ (offset data)}}{\lambda \text{ (pitch interval)}}$$

The remainder resulting from the division is displayed.

Diagnosis 381 Offset data from the Inductosyn

[Data type] 2-word axis

[Unit of data] Detection unit

Off set data is displayed when CNC calculates the machine position.

### Diagnosis data related to the serial spindles

	#7	#6	#5	#4	#3	#2	#1	#0
Diagnosis <span style="border: 1px solid black; padding: 2px;">400</span>	LNK							

#7 LNK Communication with the spindle control side has been established.

Diagnosis 403 Temperature of spindle motor

[Data type] Byte spindle

[Unit of data] °C

[Valid data range] 0 to 255

The temperature of the winding of the spindle motor is indicated.  
 This information can be used to determine the overheat alarm of the spindle.  
 (The temperature that causes an overheat alarm varies from motor to motor.)

**NOTE**

- 1 Temperature information has the following error:
  - 50°C to 160°C ±5°C
  - 160°C to 180°C ±10°C
- 2 The indicated temperature and the temperature causing an overheat alarm have the following error:
  - For lower than 160°C 5°C maximum
  - For 160 to 180°C 10°C maximum

		#7	#6	#5	#4	#3	#2	#1	#0
Diagnosis	408	SSA		SCA	CME	CER	SNE	FRE	CRE

- #0 **CRE** A CRC error occurred (warning).
- #1 **FRE** A framing error occurred (warning).
- #2 **SNE** The sender or receiver is not correct.
- #3 **CER** An abnormality occurred during reception.
- #4 **CME** No response was returned during automatic scanning.
- #5 **SCA** A communication alarm was issued on the spindle amplifier side.
- #7 **SSA** A system alarm was issued on the spindle amplifier side.  
 (The above conditions are major causes of alarm SP0749. These conditions are caused mainly by noise, a broken wire, a momentary failure of power, and so on.)

Diagnosis	410	Spindle load meter indication [%]
-----------	-----	-----------------------------------

[Data type] Word spindle  
 [Unit of data] %

Diagnosis	411	Spindle load meter indication [min <sup>-1</sup> ]
-----------	-----	--

[Data type] Word spindle  
 [Unit of data] min<sup>-1</sup>

Diagnosis	417	Spindle position coder feedback information
-----------	-----	---

[Data type] 2-word spindle  
 [Unit of data] Detection unit

Diagnosis	418	Positional deviation of spindle in position loop mode
-----------	-----	---

[Data type] 2-word spindle  
 [Unit of data] Detection unit

Diagnosis	425	Spindle synchronization error
-----------	-----	-------------------------------

[Data type] 2-word spindle  
 [Unit of data] Detection unit  
 When the spindles are in synchronization mode, the absolute value of the synchronization error when each spindle is set as the slave axis is indicated.

Diagnosis	445	Spindle position data
-----------	-----	-----------------------

[Data type] Word spindle  
 [Unit of data] Pulse  
 [Valid data range] 0 to 4095  
 For the serial spindle, position coder signal pulse data from the one-rotation signal is indicated as the position data of the spindle.  
 This data is valid when bit 1 of parameter No. 3117 is set to 1.  
 To display spindle position data, spindle orientation must be performed once.

## Diagnosis data related to rigid tapping

Diagnosis

[Data type] 2-word spindle  
[Unit of data] Detection unit

Diagnosis

[Data type] 2-word spindle  
[Unit of data] Detection unit

Diagnosis

[Data type] 2-word spindle  
[Unit of data] %

Diagnosis

[Data type] 2-word spindle  
[Unit of data] %

Diagnosis

[Data type] 2-word spindle  
[Unit of data] Detection unit

Diagnosis

[Data type] 2-word spindle  
[Unit of data] Detection unit

Diagnosis

[Data type] 2-word spindle  
[Unit of data] Detection unit

Diagnosis

[Data type] 2-word spindle  
[Unit of data] Detection unit

Diagnosis

[Data type] 2-word spindle  
[Unit of data] Detection unit

Diagnosis

[Data type] 2-word path

Diagnosis

[Data type] 2-word spindle  
[Unit of data] Detection unit

Diagnosis

[Data type] 2-word spindle  
[Unit of data] Detection unit

Diagnosis

[Data type] 2-word spindle  
[Unit of data] Detection unit

**Diagnosis data related to polygon machining with two spindles**

	#7	#6	#5	#4	#3	#2	#1	#0
Diagnosis	470	SC0	LGE	SCF	PSC	PEN	PSU	SPL

- #0 **SPL** Polygon synchronization with two spindles under way
- #1 **PSU** Polygon synchronization mode with two spindles being activated

**NOTE**  
 If only PSU becomes 1, but no change occurs, and the program stops in a block containing a G51.2 command, the speed of an spindle does not reach the targeted polygon synchronization speed, for example, because bit 7 (PST) of parameter No. 7603 = 0 keeps the spindle from being energized.

- #2 **PEN** Polygon synchronization mode with two spindles released
- #3 **PSC** Spindle speed being changed during polygon synchronization mode with two spindles
- #4 **SCF** Spindle speed changed during polygon synchronization mode with two spindles
- #6 **LGE** The loop gain is different between the spindles during polygon synchronization mode with two spindles.

**NOTE**  
 When the speed is changed during polygon synchronization mode, LGE is set to 1 if the spindle synchronization control loop gain used by the serial spindle control unit is different between the master spindle and polygon synchronization axis.  
 Diagnosis display indicates the loop gain because this function requires that both spindles be controlled with the same loop gain. However, no alarm is issued even if the loop gain is different between the spindles.  
 (For the serial spindle control unit, the parameters used are changed according to the state of the CTH1 and CTH2 signals.)

- #7 **SC0** Actual speed command is 0 during polygon synchronization mode with two spindles.

**NOTE**  
 Signal SC0 is not a value specified by the program. It is set to 1 under any of the following conditions:  
 1. When the S command value is adjusted according to the signals related to spindle control, SSTP<Gn029.6> and SOV0-SOV7<Gn030> and the signal related to multi-spindle control <Gn027>, the result is 0.  
 2. The S command value is smaller than the spindle control resolution (the result of multiplying the S command value by a value of 4095/(maximum spindle speed) is less than 1). The S command value is specified by SIND control <Gn032, Gn033>, and it is 0.  
 If SC0 = 1, the spindle speed becomes 0 and bit 0 of diagnosis display No. 471 becomes 1. In this case, the polygon synchronization rotation ratio is impractical, but alarm PS5018 does not occur, because it is regarded as the result of the command.

If the following status is indicated during the polygon synchronization mode, there are no abnormalities.

		#7	#6	#5	#4	#3	#2	#1	#0
Diagnosis	470	0	0	0	1	-	0	0	1

		#7	#6	#5	#4	#3	#2	#1	#0
Diagnosis	471	NPQ	PQE	QMS	NSP	SUO	QCL		SCU

Polygon turning with two spindles

Indication of causes for alarms PS5018, PS0314, and PS0218

#0 to #3 Causes for alarm PS5018

Alarm PS5018 is cleared by a reset, but the indication of its causes remains until the causes are cleared or the polygon synchronization mode is released.

SCU The specified speed is too low during polygon synchronization mode with two spindles.  
(The unit of speed calculated internally becomes 0.)

#### NOTE

SCU becomes 1 also when the specified spindle speed is 0 (diagnosis display No. 470#7 = 1). In this case, however, alarm PS5018 is not issued (because the command is 0). When diagnosis display No. 470#7 = 0 and diagnosis display No. 471#0 = 1, alarm PS5018 occurs. Normally this does not occur with speed at which the spindle can rotate.

QCL The polygon synchronization axis is clamped.

#### NOTE

QCL becomes 1, when the polygon synchronization axis receives a command with a polygon synchronization speed that is higher than the value specified in parameter No. 7621 and is clamped at that speed.

SUO The specified speed is too high during the polygon synchronization mode with two spindles.  
(It is clamped to the upper limit calculated internally.)

#### NOTE

SUO occurs, if a result of (speed specified for the master spindle)/(value specified at P) is higher than 59998. In other words, the master spindle must rotate at a speed lower than  $59998 \text{ min}^{-1}$  assuming  $P = 1$ .

#4 Causes for alarm PS0314

When alarm PS0314 occurs, the polygon synchronization mode is released, but the indication of its causes remains until the alarm PS0314 is cleared by a reset.

NSP A spindle necessary for control is not connected.  
(For example, there is not a serial spindle or the second spindle.)  
The axis settings for polygon turning are not correct.

#5 to #7 Causes for alarm PS0218

When alarm PS0218 occurs, the polygon synchronization mode is released, but the indication of its causes remains until the alarm PS0218 is cleared by a reset.

QMS When bit 1 (QDR) of parameter No. 7603 = 1, a negative value is specified at Q.

PQE In a G51.2, either P or Q has a value out of the specifiable range.  
Or, P and Q are not specified as a pair.

NPQ In a G51.2, R is specified when P and Q have not been specified at all, or none of P, Q, and R has been specified.

Indication of values specified during the polygon synchronization mode with two spindles

Diagnosis	474	<b>Rotation ratio for the master axis during the polygon synchronization mode with two spindles (P command value)</b>
-----------	-----	---

This indication is the current rotation ratio (P command value) of the master axis during the polygon synchronization mode with two spindles.

Diagnosis	475	<b>Rotation ratio for the polygon synchronization axis during the polygon synchronization mode with two spindles (Q command value)</b>
-----------	-----	--

This indication is the current rotation ratio (Q command value) of the polygon synchronization axis during the polygon synchronization mode with two spindles.

### Diagnosis data related to the small-hole peck drilling cycle

Diagnosis	520	<b>Total number of times a retraction operation has been performed during drilling since G83 was specified</b>
-----------	-----	--

Diagnosis	521	<b>Total number of times a retraction operation has been performed in response to the reception of the overload torque detection signal during drilling since G83 was specified</b>
-----------	-----	---

The total numbers of times output in Nos.520 and 521 are cleared to zero by a G83 command issued after the small-hole peck drilling cycle mode is entered.

Diagnosis	522	<b>Coordinate value of the drilling axis at which retraction operation starts (least input increment)</b>
-----------	-----	---

Diagnosis	523	<b>Difference between the coordinate value of the drilling axis at which the previous retraction operation started and the coordinate value of the drilling axis at which the current retraction operation starts (least input increment: previous value minus current value)</b>
-----------	-----	---

### Diagnosis data related to the dual position feedback function

Diagnosis	550	<b>Closed loop error</b>
-----------	-----	--------------------------

[Data type] 2-word axis

[Unit of data] Detection unit

[Valid data range] -99999999 to +99999999

Diagnosis	551	<b>Semi-closed loop error</b>
-----------	-----	-------------------------------

[Data type] 2-word axis

[Unit of data] Detection unit

[Valid data range] -99999999 to +99999999

Diagnosis	552	<b>Error between semi-closed and closed loops</b>
-----------	-----	---

[Data type] Word axis

[Unit of data] Detection unit

[Valid data range] -32768 to +32767



Diagnosis **553****Amount of dual position compensation**

[Data type] 2-word axis

[Unit of data] Detection unit

[Valid data range] -99999999 to +99999999

The data items displayed on the diagnosis screen are obtained at the following positions:

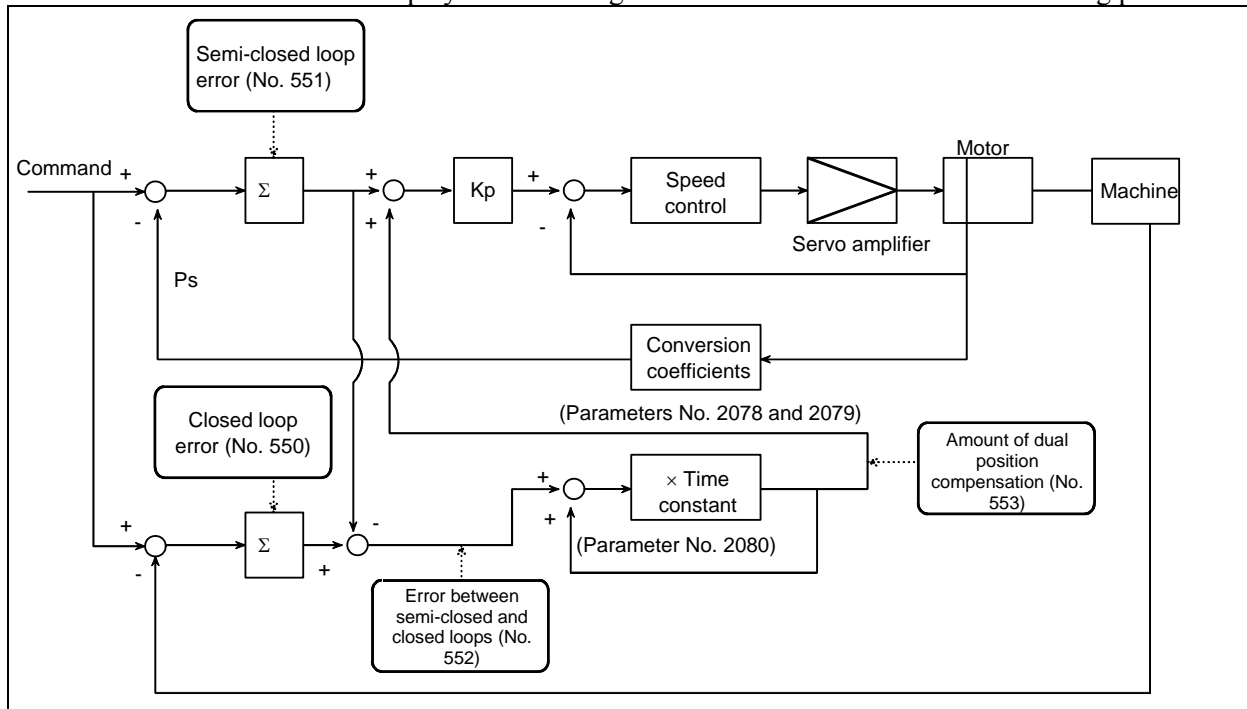

### Automatic alteration of tool position compensation

Diagnosis **0560****Manual tool compensation state number**

[Data type] Byte

[Unit of data] None

[Valid data range] 0 to 255

When incomplete operation was performed in manual tool compensation, one of the following numbers is used for notification.

- 0 : Manual tool compensation was completed normally.
- 1 : The data of T code command falls outside the allowable range.
- 2 : The offset value falls outside the range.
- 3 : The offset number falls outside the range.
- 4 : Automatic operation or axis movement is being performed in the CNC.
- 5 : The CNC is in the tool-nose radius compensation mode.
- 6 : The CNC is in a mode other than the JOG mode, HNDL (INC) mode, and REF mode.
- 7 : A CNC parameter is illegal.
- 8 : The CNC is in the 3-dimensional cutter compensation mode or tool center point control mode.

**Data for adjusting the compensation of the start position of thread cutting when the spindle speed is changed**

Diagnosis	670	Delay in acceleration/deceleration after interpolation that is calculated in the NC
Diagnosis	671	Servo delay calculated in the NC
Diagnosis	672	Delay in one-rotation signal detection that is calculated in the NC

[Data type] 2-word path

[Unit of data] Metric input: 0.00001mm

Inch input : 0.000001inch

[Valid data range] 0 to 99,999,999

Compensation amounts calculated by the NC are indicated. Use them to set adjustment parameters Nos. 1446 to 1449.

**State of high-speed HRV current control**

		#7	#6	#5	#4	#3	#2	#1	#0
Diagnosis	700						DCLNK	HOK	HON

[Data type] Bit axis

The state of high-speed HRV current control is displayed.

**#0 HON** The motor is controlled in the high-speed HRV current control mode.

**#1 HOK** This bit is set to 1 when high-speed HRV current control is enabled.

High-speed HRV current control is enabled when the following conditions are satisfied:

- Bit 0 (HR3) of parameter No. 2013 is set to 1.
- Bit 0 (HR4) of parameter No. 2014 is set to 1.
- Servo software, servo modules, and servo amplifiers suitable for high-speed HRV current control are used.
- When a separate detector interface unit is used, the separate detector interface unit is suitable for high-speed HRV current control.

**#2 DCLNK** This bit is set to 1 when voltage information can be output to the diagnosis screen.

**Thermal growth compensation along tool vector**

Diagnosis	705	Thermal growth compensation amount for each axis
-----------	-----	--

[Data type] Word axis

[Unit of data] Detection unit

[Valid data range] -32768 to +32767

The compensation amount for each axis in thermal growth compensation along the tool vector is indicated.

**Spindle error and warning states**

Diagnosis	710	Spindle error state
-----------	-----	---------------------

[Data type] Word spindle

Diagnosis	712	Spindle warning state
-----------	-----	-----------------------

[Data type] Word spindle

When an error (yellow LED ON + error number indication) or a warning occurs in a Spindle Amplifier (SP), the number is indicated on the diagnosis screen. If neither error nor warning occurs, 0 is indicated.

For spindle errors, refer to "FANUC SERVO MOTOR  $\alpha$ i series Maintenance Manual" (B-65285EN).

For warnings, see Subsection 10.1.4, "Spindle Warning Interface" in this manual.

**OVC level**

Diagnosis	750	OVC level						
-----------	-----	-----------	--	--	--	--	--	--

[Data type] Word axis

[Unit of data] %

The proportion of soft thermal (OVC) in the alarm issuance level is indicated.

**Linear inclination compensation function**

Diagnosis	751	Each axis linear inclination compensation						
-----------	-----	---	--	--	--	--	--	--

[Data type] Word axis

[Unit of data] Detection unit

[Valid data range] -32768 to +32767

Compensation of linear inclination compensation for each axis is indicated.

**DC link voltage information**

Diagnosis	752	DC link voltage information						
-----------	-----	-----------------------------	--	--	--	--	--	--

[Data type] Word axis

[Unit of data] Vrms

[Valid data range] 0 to 452 (200 Vrms input amplifier)

0 to 905 (400 Vrms input amplifier)

DC link voltage information is indicated.

**Servo motor**

Diagnosis	760	R phase current value						
-----------	-----	-----------------------	--	--	--	--	--	--

[Data type] Word axis

[Unit of data] Value 6554 is equivalent to the maximum amplifier current.

[Valid data range] -6554 to +6554

The actual R phase current value of the servo motor is indicated.

Diagnosis	761	Effective current value						
-----------	-----	-------------------------	--	--	--	--	--	--

[Data type] Word axis

[Unit of data] Value 8027 is equivalent to the maximum amplifier current.

[Valid data range] -8027 to +8027

The effective current value of the servo motor is indicated.

Diagnosis	762	Activating phase						
-----------	-----	------------------	--	--	--	--	--	--

[Data type] Word axis

[Unit of data] Value 256 is equivalent to 360 degrees.

[Valid data range] 0 to 255

The activating phase (electrical angle) of the servo motor is indicated.

**Reason why a start cannot be performed**

		#7	#6	#5	#4	#3	#2	#1	#0
Diagnosis	1006							ALM	*SP

[Data type] Bit

The reason why a start cannot be performed is displayed.

#0 \*SP The feed hold signal (\*SP) is 0.

#1 ALM An alarm occurs.

**Automatic data backup**

		#7	#6	#5	#4	#3	#2	#1	#0
Diagnosis	1016	ANG	ACM			DT3	DT2	DT1	AEX

[Data type] Bit

The execution state of backup is indicated.

#0 AEX Automatic data backup is being performed.

- #1 **DT1** Data 1 was updated in the previous backup.
- #2 **DT2** Data 2 was updated in the previous backup.
- #3 **DT3** Data 3 was updated in the previous backup.
- #6 **ACM** Automatic data backup was performed.
- #7 **ANG** An error occurred in automatic data backup.

### Fan rotation speed

Diagnosis

Diagnosis

Diagnosis

Diagnosis

[Data type] 2-word

[Unit of data] 1/min

FAN1, FAN2

The rotation speed of the fans in the CNC controller are indicated.

FAN3, FAN4

The rotation speed of the fans in the stand-alone CNC with 15" LCD display are indicated.

If there is no applicable fan, 0 is indicated.

### Custom macro / execution macro / auxiliary macro

Diagnosis

[Data type] 2-word

[Unit of data] Block

Displays the number of blocks in the macro statements executed by a custom macro/execution macro per 1024 ms.

It provides an indication of the actual processing speed of macro statements.

Diagnosis

[Data type] 2-word

[Unit of data] Block

Displays the number of blocks executed by an auxiliary macro per 1024 ms.

It provides an indication of the actual processing speed of auxiliary macros.

### Spindle revolution number history function

Diagnosis

Diagnosis

[Data type] 2-word spindle

[Unit of data] 1000 min<sup>-1</sup>

[Valid data range] 0 to 999999999

The number of revolutions of the spindle is counted and the total number of revolutions is indicated.

### Built-in 3D interference check

[Data type] Word

[Unit of data] msec

[Description] Displays the current processing time required for 3D interference check.



Detail alarm No.	Parameter number	Cause	Action
120 451 452	-	The FSSB internal status did not change to open.	Check the connection between the CNC and each amplifier. Alternatively, the servo card may be faulty.
140 450	24000 to 24095	The ATR value is inconsistent with the connected slave (servo, spindle, or separate detector).	Set the ATR value corresponding to the connected slave.
271	3717 24000 to 24095	The spindle amplifier number corresponding to the ATR value setting is not set.	Make the spindle amplifier number consistent with the ATR value setting.
272	24000 to 24031 24064 to 24095	The fifth to eighth separate detector is set for the first FSSB line (third FSSB line).	Do not set the fifth to eighth separate detectors for the first FSSB line (third FSSB line).
273	24032 to 24063	The first to fourth (ninth to twelfth) separate detector is set for the second FSSB line.	Do not set the first to fourth (ninth to twelfth) separate detectors for the second FSSB line.
276	24000 to 24095	The setting for a separate detector is made more than once.	Make the setting for each separate detector only once in the servo card.
290	24000 to 24095	The maximum number of slaves per FSSB line is exceeded for an FSSB line of servo HRV2 control.	Reduce the number of slaves to 32 (maximum number of slaves per FSSB line of servo HRV2 control) or less.
291	24000 to 24095	The maximum number of slaves per FSSB line is exceeded for an FSSB line of servo HRV3 control.	Reduce the number of slaves to 15 (maximum number of slaves per FSSB line of servo HRV3 control) or less.
293	24000 to 24095	The maximum number of slaves per FSSB line is exceeded for an FSSB line of servo HRV4 control.	Reduce the number of slaves to 7 (maximum number of slaves per FSSB line of servo HRV4 control) or less.
310	1023 24104 to 24199	The servo axis number corresponding to the ATR value setting of a separate detector is not set for parameter No. 1023.	Set the value corresponding to the ATR value setting for parameter No. 1023.
313	1023 14476#5 24104 to 24199	The servo axis number corresponding to the ATR value setting of a separate detector is not set for parameter No. 1023.	Set the value corresponding to the ATR value setting for parameter No. 1023.
314	1023 14476#5 24104 to 24199	The ATR value setting of a separate detector is invalid.	Correct the settings of parameters Nos. 24104 to 24199.
383	-	Manual setting 1 cannot be performed when a separate detector is used.	Disconnect the separate detector. Alternatively, perform manual setting or automatic setting.
453	-	Servo initialization has not completed successfully.	An optical cable may be faulty or the connection between the amplifier and another module may be incorrect.
454	-	Alarm No. 550 to 556 of diagnostic data No. 3511 occurred.	Check diagnostic data No. 3511.
460	24000 to 24095	The ATR value of a spindle or separate detector is set for a slave which is not connected.	Set the ATR value corresponding to the connected slave.
471	24000 to 24095	Although a separate detector is connected, the separate detector setting is not made.	Set the value for the separate detector in the corresponding parameter.
480	24000 to 24095	In ATR value setting, a servo axis number exceeds 80.	Make settings so that any servo axis number does not exceed 80.

Diagnosis	3511	FSSB alarm number
-----------	------	-------------------

[Data type] Word axis

Information is output for identifying the location (parameter) and cause of an FSSB-related alarm which has been issued. For the displayed detail numbers and corresponding causes and actions, see the table below. When multiple FSSB alarm numbers appear, address the alarms in ascending order of the FSSB alarm number.

Detail alarm No.	Parameter number	Cause	Action
210	24096 to 24103	Although a separate detector is not set, a value is set in parameter No. 24096 to 24103.	Set parameter Nos. 24096 to 24103 to all 0.
220	1023	An unavailable servo axis number is set.	Change the servo axis number.
221	1023	A servo axis number is set more than once.	Change the servo axis number.
250	24096 to 24103	For a specific servo axis, two or more separate detectors are used and the paired separate detectors are two of the first, third, fifth, and seventh units or the second, fourth, sixth, and eighth units.	To use two separate detectors for a specific servo axis, one separate detector must have an odd number and the other must have an even number. Three or more separate detectors cannot be used.
270	1023 24000 to 24095	<ul style="list-style-type: none"> <li>• The servo axis number corresponding to the ATR value setting is not set for parameter No. 1023.</li> <li>• An unavailable servo axis number is set.</li> <li>• A servo axis number is set more than once.</li> </ul>	Check the conditions on the left.
292	1023 2013#0	For an FSSB line of servo HRV3 control, only the following servo axis numbers can be used: ( $1 + 8n$ , $2 + 8n$ , $3 + 8n$ , $4 + 8n$ ( $n = 0, 1, \dots, 9$ ))	For the FSSB line of servo HRV3 control, set the servo axis numbers on the left.
294	1023 2014#0	For an FSSB line of servo HRV4 control, only the following servo axis numbers can be used: ( $1+8n(n=0,1,\dots,9)$ )	For the FSSB line of servo HRV4 control, set the servo axis numbers on the left.
311	24096 to 24103	A connector number is invalid.	Specify a value between 0 and 8.
314	24096 to 24103	A connector number is set more than once.	Make setting so that each connector number is used only once for one separate detector.
350	2013#0 2014#0	Different current loops (HRV) are used for FSSB lines.	Set the same current loop (HRV) for the FSSB lines.
360	1023 2013#0 2014#0	Different current loops (HRV) are set for the first and second FSSB lines and parameter No. 1023 setting is invalid.	Set servo axis numbers so that each set of (1 to 6), (9 to 14), (17 to 22), (25 to 30), (33 to 38), and (41 to 46) is set for the same FSSB line.
370	1902#0 1902#1 2013#0 2014#0	When servo HRV3 or HRV4 control is set, manual setting 1 cannot be performed.	To set servo HRV3 or HRV4 control, perform manual setting or automatic setting.
380	1023	When a servo axis number is skipped, manual setting 1 cannot be performed.	Set servo axis numbers without skipping any number.

Detail alarm No.	Parameter number	Cause	Action
382	1023	An attempt was made to perform manual setting 1 though the maximum number of controlled axes per FSSB line is exceeded.	Reduce the number of connected servo axes to the maximum number of controlled axes or less.
470	24000 to 24095	An ATR value is set more than once.	Set each ATR value only once.
481	1023 24000 to 24095	A servo axis number is inconsistent with the ATR value setting or the servo motor having a servo axis number is not connected.	Check whether the value set in parameter No. 1023 is consistent with ATR value setting and whether the servo motor corresponding to each servo axis number is connected.
520	2165	At power-on, amplifier ID information could not be read.	Check the connection between the CNC and each amplifier. Alternatively, an amplifier may be faulty.
550	1023 24000 to 24095	The ATR value setting is inconsistent with the servo axis number setting.	Make the value set in parameter No. 1023 consistent with the ATR value setting.
551	24000 to 24095	The number of ATR value settings exceeds the number of slaves connected to the CNC.	Make as many settings as the number of slaves connected to the CNC.
552	1023	An unavailable servo axis number is set.	Change the servo axis number.
553	1023	A servo axis number is set more than once.	Change the servo axis number.
554	24096 to 24103	A value is set in parameter No. 24096 to 24103 though no separate detector is connected.	Set parameters Nos. 24096 to 24103 to all 0.
555 557 558	2165	The maximum current of an amplifier (parameter No. 2165) differs from that of a motor.	Set the maximum current of the amplifier (parameter No. 2165) to that of the motor.
1023	1023	An invalid servo axis number is set.	Set a correct servo axis number.

Diagnosis

[Data type] Word spindle

Information is output for identifying the location (parameter) and cause of an FSSB-related alarm which has been issued.

For the displayed detail numbers and corresponding causes and actions, see the table below. When multiple FSSB alarm numbers appear, address the alarms in ascending order of the FSSB alarm number.

Detail alarm No.	Parameter number	Cause	Action
271	3717 24000 to 24095	An ATR value is set more than once.	Make each spindle amplifier consistent with the ATR value setting.
381	3717	When a spindle amplifier number is skipped, manual setting 1 cannot be performed.	Set spindle amplifier numbers without skipping any number.

### Diagnosis data related to linear scale with absolute address reference marks

Diagnosis

Diagnosis

Diagnosis



Diagnosis	3548	Linear scale with absolute address reference marks: Measurement point 4
-----------	------	---

[Data type] 2-word axis

[Unit of data] Detection unit

[Valid data range] -999999999 to 999999999

Diagnosis	3549	Linear scale with absolute address reference marks: Status display
-----------	------	--

Diagnosis	3550	Linear scale with absolute address reference marks: Scale value
-----------	------	---

[Data type] 2-word axis

[Unit of data] Detection unit

[Valid data range] -999999999 to 999999999

Diagnosis	3551	Linear scale with absolute address reference marks: Scale value (High)
-----------	------	--

[Data type] 2-word axis

[Unit of data] Detection unit

[Valid data range] -999 to 999

Linear scale with absolute address reference marks

Scale value = Diagnosis No.3551 × 1,000,000,000 + Diagnosis No.3550

### Wrong operation prevention function

	#7	#6	#5	#4	#3	#2	#1	#0
Diagnosis	3570							MSC

[Data type] Bit path

#0 MSC Memory operation is stopped due to the reconfirming of midway block start.

In a multipath system, the bit is set to 1 on only the path on which the cursor is position in the middle of the program.

### Diagnosis data related to flexible path axis assignment

Diagnosis	4000	Reason number of alarm in flexible path axis assignment
-----------	------	---

The cause of the alarm that may be issued in flexible path axis assignment is displayed.

- 1 The number of axes in the path is 0.
- 2 The number of axes in the path is larger than its allowable maximum value.
- 3 The removal command has no ID specification.
- 4 The removal command has a duplicate ID specification.
- 5 An axis specified with removal command P does not exist in the path or has been removed from the path.
- 6 An axis specified with removal command Q does not exist in the path or has been removed from the path.
- 7 An axis specified with removal command R does not exist in the path or has been removed from the path.
- 8 An axis specified with the removal command does not exist in the path or has been removed from the path.
- 9 The removal command has no axis specification or has an ID specification.
- 10 In flexible path axis assignment, the ID specification is incorrect.
- 11 The assignment command has no ID specification.
- 12 The assignment command has a duplicate ID specification.
- 13 The assignment command has a duplicate axis arrangement specification.
- 14 The path specified with the arrangement command has no target axis or the arrangement command has no ID specification.
- 15 The path specified with the arrangement command has an invalid axis assignment specification.

- 16 An axis whose removal a command is waiting for belongs to the path where the command was issued.
- 18 An axis whose removal an exchange command is waiting for belongs to the path paired with the path where the exchange command was issued.
- 19 An axis for which an assignment command was issued is yet to be removed. (Bit 1 of parameter No. 11561 is set to 1.)
- 20 An axis for which an assignment command is issued in a path belongs to another path where a removal command for it has been issued.
- 21 An axis for which an assignment command was issued is yet to be removed.
- 22 The assignment command has no axis specification or has an ID specification.
- 24 An axis at which an exchange command is targeted belongs to the path where the exchange command was issued.
- 25 The exchange command has no ID specification.
- 26 The exchange command has a duplicate ID specification.
- 27 In a system having 3 or more paths, an exchange command has no L specification.
- 28 An axis targeted by an exchange command was not found in the source path (path where this exchange command was issued).
- 29 An axis specified in the exchange command is being processed by another command or has already been removed.
- 30 An axis targeted by an exchange command was not found in the destination path (path paired with a path where another exchange command was issued for the axis).
- 32 The exchange command has no target axis.
- 33 The exchange command has a conflict.
- 34 The exchange command has no axis specification or has an ID specification.
- 35 A cycle other than flexible path axis assignment is under way.
- 36 An attempt was made to perform flexible path axis assignment during the SV rotation control mode.
- 37 An attempt was made to perform flexible path axis assignment during the polygon turning mode.
- 38 An attempt was made to perform flexible path axis assignment during PMC axis control.
- 39 An attempt was made to perform flexible path axis assignment during the chopping mode.
- 40 An attempt was made to perform flexible path axis assignment during mirror imaging.
- 41 An attempt was made to perform flexible path axis assignment during 3-dimensional coordinate conversion.
- 42 An attempt was made to perform flexible path axis assignment during coordinate system rotation.
- 43 An attempt was made to perform flexible path axis assignment during scaling.
- 44 An attempt was made to perform flexible path axis assignment during axis synchronization.
- 45 An attempt was made to perform flexible path axis assignment for an axis already removed.
- 46 An attempt was made to perform flexible path axis assignment for an axis under composite control.
- 47 An attempt was made to perform flexible path axis assignment for an axis under synchronous control.
- 48 An attempt was made to perform flexible path axis assignment for an axis under superimposed control.
- 55 An attempt was made to perform flexible path axis assignment simultaneously with an axis move command.
- 56 An attempt was made to perform flexible path axis assignment during tool compensation.

Diagnosis	4001	Belonging path of axis in flexible path axis assignment
-----------	------	---

A path (specified by parameter No. 981) to which an axis specified for flexible path axis assignment belongs is displayed.

0 : Source path  
 1 to 10 : Destination path (because of assignment or exchange)  
 -1 to -10 : Already removed

### Pulse superimposed function

Diagnosis	4110	Number of accumulated pulses specified by the pulse superimposed function
-----------	------	---

[Data type] Floating point number axis  
 [Unit of data] Input unit

The number of accumulated pulses specified by pulse superimposition is indicated. The number multiplied by the travel distance magnification is indicated.

Diagnosis	4110	Number of accumulated pulses specified by the pulse superimposed function
-----------	------	---

[Data type] Floating point number axis  
 [Unit of data] Input unit

When the maximum cutting feedrate is to be exceeded by the specified pulse superimposition, the pulses exceeding the allowable number (set in parameter No. 7117) are discarded.

This diagnosis data indicates the number of accumulated pulses that are actually discarded in pulse superimposition.

$|\text{Number of pulses specified by pulse superimposition} \times \text{travel distance magnification}| > |\text{maximum cutting feedrate} + \text{allowable number of pulses}|$   
 $\rightarrow$  Number of discarded pulses  
 $= \text{Number of pulses specified by pulse superimposition} \times \text{travel distance magnification} - \text{maximum cutting feedrate} - \text{allowable number of pulses}$

$|\text{Number of pulses specified by pulse superimposition} \times \text{travel distance magnification}| < |\text{maximum cutting feedrate} + \text{allowable number of pulses}|$   
 $\rightarrow$  Number of discarded pulses = 0

#### NOTE

When the pulse superimposed function is disabled (bit 0 (PSI) of parameter No. 10350 is set to 0), reset operation clears the indicated number of accumulated/discarded pulses.

### Total of the current actual power consumption of all servo axes/spindles

Diagnosis	4900	Total of current actual power consumption of all axes
-----------	------	---

[Data type] 2-word  
 [Unit of data] W

#### NOTE

The actual power consumption is obtained by subtracting the regenerative power from the power consumption. If the regenerative power exceeds the power consumption, the actual power consumption becomes a negative value.

### Current actual power consumption of each servo axis

Diagnosis	4901	Current actual power consumption of each servo axis
-----------	------	---

[Data type] 2-word axis

[Unit of data] W

**NOTE**  
This power consumption becomes a negative value during regeneration of power such as reduction in servo axis speed.

**Current actual power consumption of each spindle**

Diagnosis

[Data type] 2-word spindle

[Unit of data] W

**NOTE**  
This power consumption becomes a negative value during regeneration of power such as reduction in spindle speed.

**Accumulated value of the total power consumption of all servo axes/spindles**

Diagnosis

Diagnosis

Diagnosis

[Data type] 2-word

[Unit of data] 0.001kWh

**NOTE**  
These values are accumulated after power-on.

**Accumulated value of power consumption of each servo axis**

Diagnosis

Diagnosis

Diagnosis

[Data type] 2-word axis

[Unit of data] 0.001kWh

**NOTE**  
These values are accumulated after power-on.

**Accumulated value of power consumption of each spindle**

Diagnosis

Diagnosis

Diagnosis

[Data type] 2-word spindle

[Unit of data] W

**NOTE**  
These values are accumulated after power-on.

**Interpolation state**Diagnosis 

[Data type] Bit

NAME Interpolation state when "1" is indicated

Smooth IPL on When smooth interpolation G5.1 Q2 is specified and all conditions are satisfied, "1" is indicated. The G5.1 Q2 command turns on AI contour control at the same time. Therefore, the AI contour control mode signal AICC<Fn062.0> turns on and AICC1/AICC2 blinks in the state display at the lower right of the screen.

SMOOTHING ON When nano smoothing G5.1 Q3 is specified and all conditions are satisfied, "1" is indicated. The G5.1 Q3 command turns on AI contour control at the same time. Therefore, the AI contour control mode signal AICC<Fn062.0> turns on and AICC1/AICC2 blinks in the state display at the lower right of the screen.

**3-dimensional machine position compensation**Diagnosis 

[Data type] 2-word axis

[Unit of data] Detection unit

The compensation value of 3-dimensional machine position compensation is indicated.

**Diagnosis data related to automatic phase synchronization for flexible synchronous control**Diagnosis Diagnosis Diagnosis Diagnosis 

[Data type] Real path

[Unit of data] mm, inch, deg (machine unit)

Error between master axis and slave axis after executing automatic phase Synchronization for flexible synchronous control is displayed.

This data is displayed in the path of slave axis in inter-path flexible synchronous control.

Diagnosis Diagnosis Diagnosis Diagnosis 

[Data type] Real path

[Unit of data] mm, inch, deg (machine unit)

Maximum error between master axis and slave axis after executing automatic phase synchronization for flexible synchronous control is displayed.

This data is displayed in the path of slave axis in inter-path flexible synchronous control.

This data is cleared when automatic operation is started in auto mode.

This data is cleared when flexible synchronous control is started in manual mode.

## 1.4 CNC STATE DISPLAY

### - Description of each display

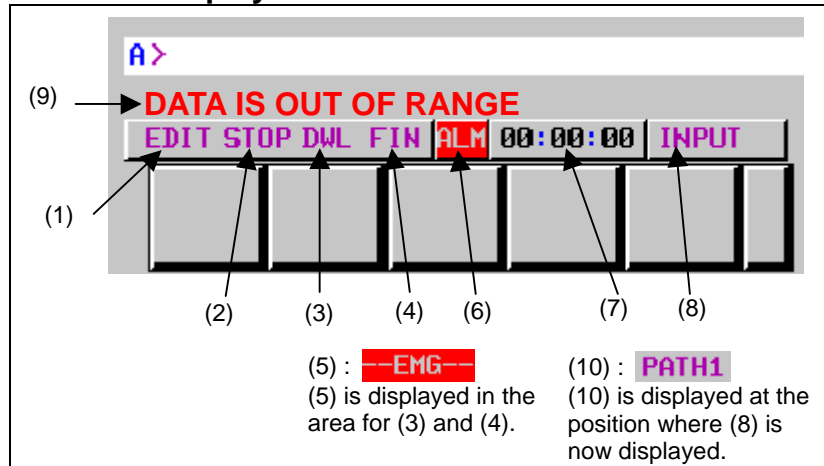

Fig. 1.4

#### (1) Current mode

- MDI : Manual data input, MDI operation
- MEM : Automatic operation (memory operation)
- RMT : Automatic operation (DNC operation, or such like)
- EDIT : Memory editing
- HND : Manual handle feed
- JOG : Jog feed
- INC : Manual incremental feed
- REF : Manual reference position return

#### (2) Automatic operation status

- \*\*\*\* : Reset (When the power is turned on or the state in which program execution has terminated and automatic operation has terminated.)
- STOP : Automatic operation stop (The state in which one block has been executed and automatic operation is stopped.)
- HOLD : Feed hold (The state in which execution of one block has been interrupted and automatic operation is stopped.)
- STRT : Automatic operation start-up (The state in which the system operates automatically)
- MSTR : Manual numerical command start state (The state in which a manual numerical command is being executed)  
 Alternatively, tool retract and recover operation state (The state in which a recover operation and repositioning operation are being performed)

#### (3) Axis moving status/dwell status

- MTN : Indicates that the axis is moving.
- DWL : Indicates the dwell state.
- \*\*\* : Indicates a state other than the above.

#### (4) State in which an auxiliary function is being executed

- FIN : Indicates the state in which an auxiliary function is being executed. (Waiting for the complete signal from the PMC)
- \*\*\* : Indicates a state other than the above.

#### (5) Emergency stop or reset status

- EMG--** : Indicates emergency stop.(Blinks in reversed display.)

--RESET-- : Indicates that the reset signal is being received.

### (6) Alarm status

**ALM** : Indicates that an alarm is issued. (Blinks in reversed display.)

**BAT** : Indicates that the voltage of the lithium battery (the backup battery of the CNC) has decreased. (Blinks in reversed display.)

**APC** : Indicates that the voltage of the backup battery of the absolute pulse coder has decreased. (Blinks in reversed display.)

**FAN** : Indicates that the rotation speed of the fan has decreased. (Blinks in reversed display.)  
Check the fan motor status display screen and replace the fan motors for which the rotation speed is found to be decreased.

Space : Indicates a state other than the above.

### (7) Current time

hh : mm : ss - Hours, minutes, and seconds

### (8) Program editing status

INPUT : Indicates that data is being input.

OUTPUT : Indicates that data is being output.

SEARCH : Indicates that a search is being performed.

EDIT : Indicates that another editing operation is being performed (insertion, modification, etc.)

LSK : Indicates that labels are skipped when data is input.

RSTR : Indicates that the program is being restarted

COMPARE : Indicates that a data comparison is being made.

OFST : Indicates that the tool length compensation amount measurement mode is set (for the machining center system) or that the tool length compensation amount write mode is set (for the lathe system).

WOFS : Indicates that the workpiece origin offset amount measurement mode is set.

AICC1 : Indicates that operation is being performed in the AI contour control I mode.

AICC2 : Indicates that operation is being performed in the AI contour control II mode.

MEM-CHK : Indicates that a program memory check is being made.

WSFT : Indicates that the workpiece shift amount write mode is set.

LEN : Indicates that the active offset value change mode (tool length offset value of the M series) is set.

RAD : Indicates that the active offset value change mode (tool radius compensation amount of the M series) is set.

WZR : Indicates that the active offset value change mode (workpiece origin offset value) is set.

TOFS : Indicates that the active offset value change mode (tool offset value of the M series) is set.

OFSX : Indicates that the active offset value change mode (X-axis tool offset value of the T series) is set.

OFSZ : Indicates that the active offset value change mode (Z-axis tool offset value of the T series) is set.

OFSY : Indicates that the active offset value change mode (Y-axis tool offset value of the T series).

TCP : Indicates that operation is being performed in the tool center point control.

TWP : Indicates that operation is being performed in the tilted working plane command mode.

Space : Indicates that no editing operation is being performed.

### (9) Warning for data setting or input/output operation

When invalid data is entered (wrong format, value out of range, etc.), when input is disabled (wrong mode, write disabled, etc.), or when input/output operation is incorrect (wrong mode, etc.), a warning message is displayed. When the RS232-C communication port is being used, "CANNOT USE I/O DEVICE" is displayed.

In this case, the CNC does not accept the setting or input/output operation (retry the operation according to the message).

Example 1)

When a parameter is entered

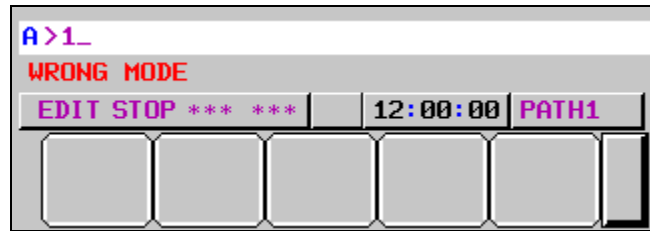

Example 2)

When a parameter is entered

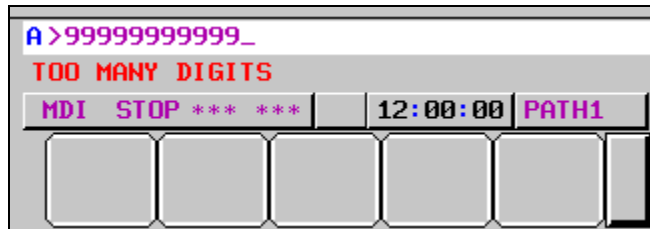

Example 3)

When a parameter is output to an external input/output device

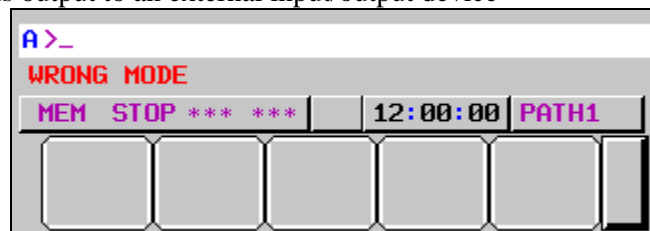

### (10) Tool post name

The number of a path whose status is indicated is displayed.

PATH1 : Indicates that the status being indicated is for path 1.

Other names can be used depending on the settings of parameters 3141 to 3147.



The tool post name is displayed at the position where (8) is now displayed.

While the program is edited, (8) is displayed.

## 1.5 OPERATING MONITOR

Load meter of the servo axis and the serial spindle and the speed meter can be displayed.

### 1.5.1 Display Method

- 1 Set a parameter to display operating monitor. (Bit 5 (OPM) of parameter No.3111)
- 2 Press the  key to display the position display screen.
- 3 Press continuous menu key , then soft key [MONITOR] is displayed.
- 4 Press the soft key [MONITOR], then the operating monitor screen is displayed.



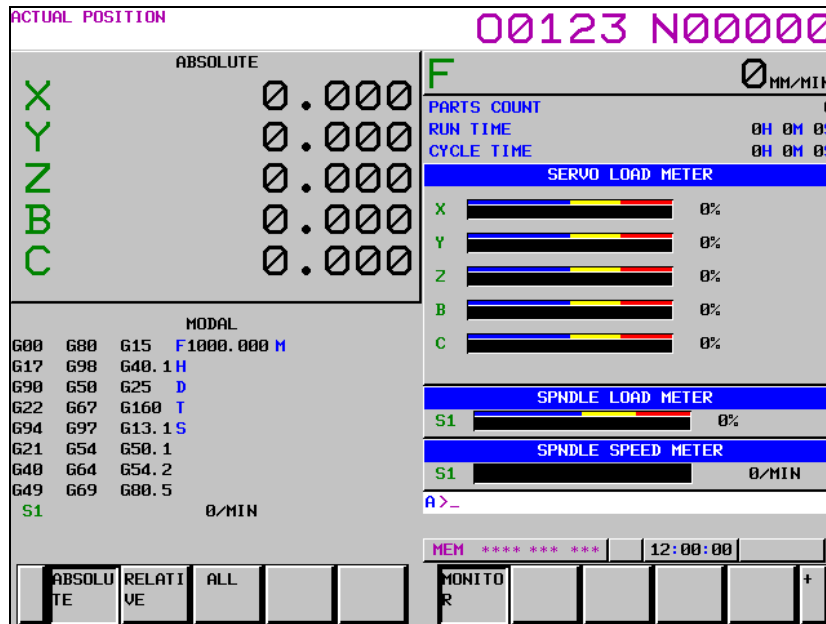

**⚠ CAUTION**

- 1 The bar graph for the load meter shows load up to 200%.
- 2 The bar graph for the speed meter shows the ratio of the current spindle speed to the maximum spindle speed (100%). Although the speed meter normally indicates the speed of the spindle motor, it can also be used to indicate the speed of the spindle by setting bit 6 (OPS) of parameter 3111 to 1.
- 3 The servo axes for their load meters are displayed are set to parameter No. 3151 to 3153. If parameters 3151 to 3153 are all zero, the load meter of the basic axes are displayed.
- 4 When high precision spindle speed control is enabled, these values are rounded off to nearest integers.

### 1.5.2 Parameters

	#7	#6	#5	#4	#3	#2	#1	#0
3111		OPS	OPM					

[Input type] Setting input

[Data type] Bit path

**#5 OPM** Operating monitor  
 0: Not displayed  
 1: Displayed

**#6 OPS** The speedometer on the operating monitor screen indicates:  
 0: Spindle motor speed  
 1: Spindle speed

## 1.6 WAVEFORM DIAGNOSIS DISPLAY

---

The waveform diagnosis display function traces values of data such as servo positional deviation amount, torque, and machine signals and plots and displays a graph representing changes in the traced data. This function facilitates servo motor and spindle motor adjustment and fault location when trouble has occurred.

The waveform diagnosis function can trace the following data:

- (1) Servo-related data
  - Positional deviation amount
  - Pulse amount after distribution
  - Torque amount (actual current)
  - Pulse amount after acceleration/deceleration
  - Current command value
  - Heat simulation data
  - Composite speed of all axes
- (2) Spindle-related data
  - Speed of each spindle
  - Load meter value
  - Difference in spindle-converted positional deviation during rigid tapping
- (3) Machine signal
  - ON/OFF state of the external I/O signal specified by a signal address

Up to four servo and spindle data items or up to 32 signals can be traced at the same time.

Data can be traced under the following three conditions:

- (1) Data is acquired at any point of time.
- (2) Data immediately after a specified event is acquired.
- (3) Data immediately before a specified event is acquired.

In condition (1), the time to end tracing can be delayed by a specified time. This allows data before and after the occurrence of an event can be acquired.

Traced data can be output to an external input/output device.

### 1.6.1 Waveform Diagnosis Graph Screen

---

- 1 Press the function key .
- 2 Pressing the soft key [W.DGNS] displays a screen as shown below.
- 3 Pressing the operation soft key [(OPRT)] displays the following soft keys:

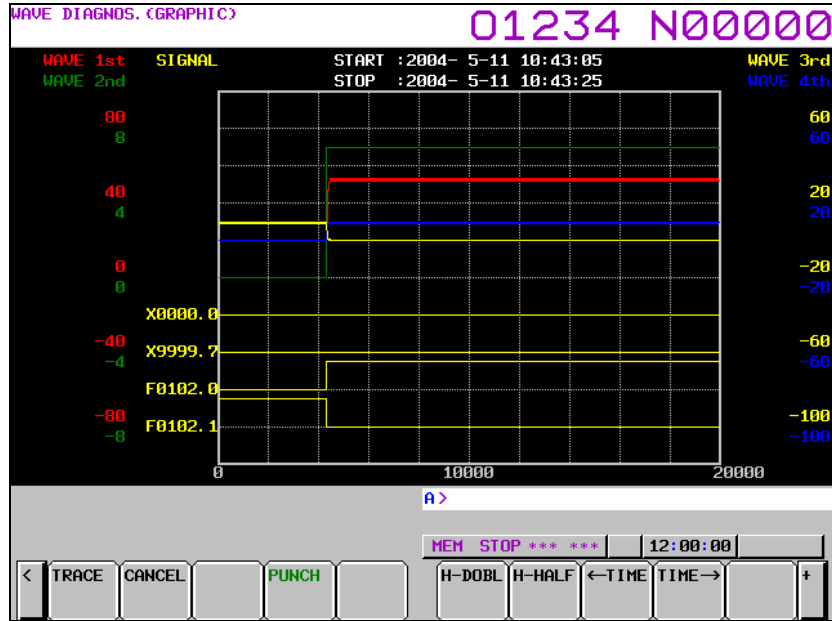

**- Servo and spindle data**

Each waveform is drawn in a specified color. The numbers and colors of the first and second waveforms are indicated in the upper left part, and the numbers and colors of the third and fourth waveforms are indicated in the upper right part.

**- I/O signals**

When displayed over the waveforms of servo and spindle data, up to four I/O signals are plotted in the lower half of the screen.

In this case, the addresses of the plotted signals are indicated in the second column on the left side.

When only signal data is displayed, up to nine signals are plotted in the entire screen.

The addresses of the plotted signals are indicated in the first column on the left side.

## 1.6.2 Waveform Diagnosis Parameter Screen

### Display

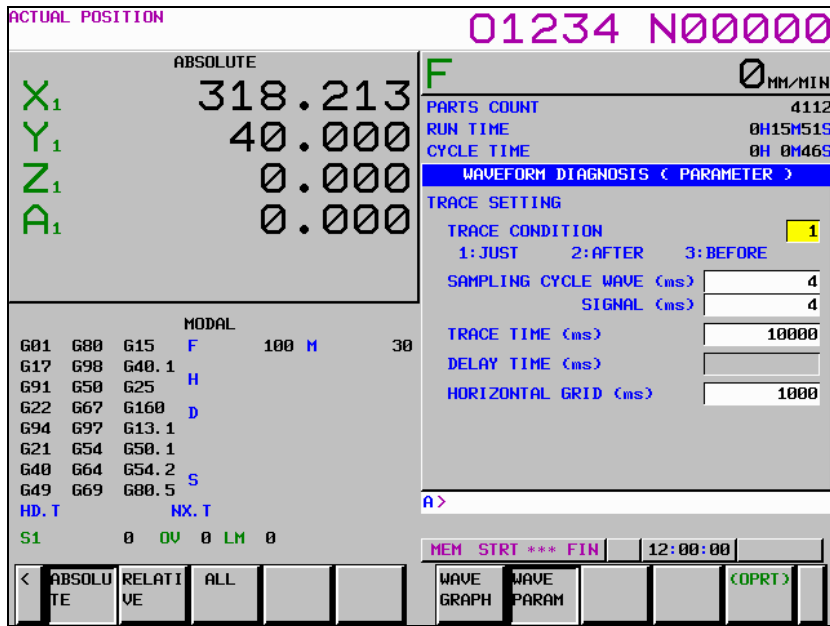

- 1 Press the function key .
- 2 Press the soft key [W.DGNS].
- 3 Pressing the soft key [PARAME] displays the waveform diagnosis parameter screen.

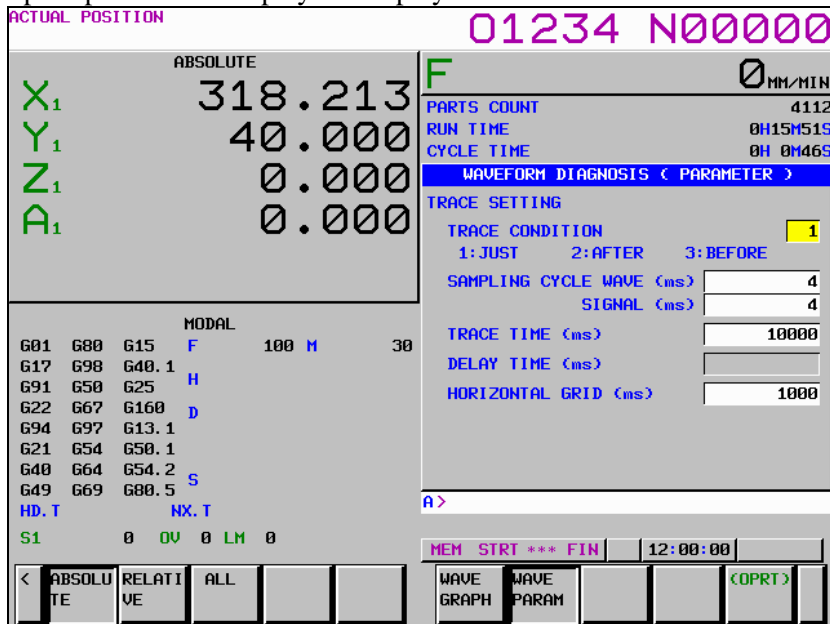

**Editing**

- 1 Follow the steps explained in "Display" to display the screen.



- 2 Pressing the   cursor keys moves the cursor on the screen.
- 3 Press numeric keys, then press the  MDI key or soft key [INPUT] to set the entered value.
- 4 Press the [(OPRT)] operation soft key to display the following operation soft keys:



Pressing continuous menu key  displays the following soft keys:



Pressing [TRACE] displays the trace setting screen of the waveform diagnosis parameter screen.  
 Pressing [WAVE] displays the waveform setting screen of the waveform diagnosis parameter screen.

Pressing [SIGNAL] displays the signal setting screen of the waveform diagnosis parameter screen.

**Trace setting**

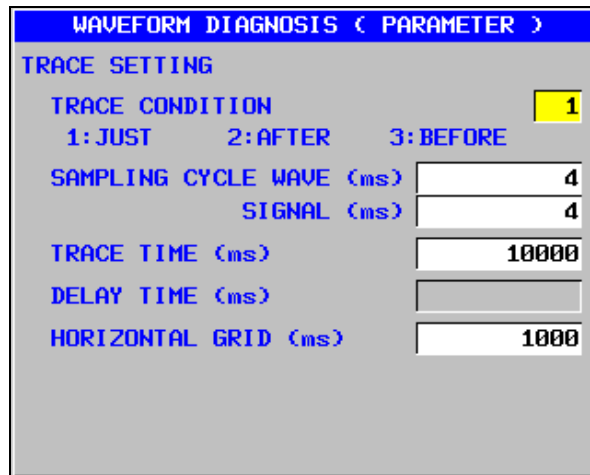

**- Trace condition**

One of the following three trace conditions can be selected to start and end tracing:

**Type 1 (1: JUST)**

Data is traced only for a specified period of time immediately after the soft key [TRACE] is pressed.

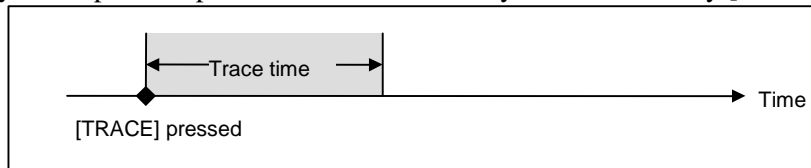

**Type 2 (2: AFTER)**

When the soft key [TRACE] has been pressed, data is traced only for a specified period of time immediately after a specified trigger event occurs.

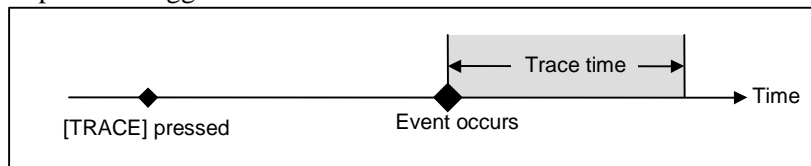

**Type 3 (3: BEFORE)**

When the soft key [TRACE] has been pressed, data is traced only for a specified period of time immediately before a specified trigger event occurs.

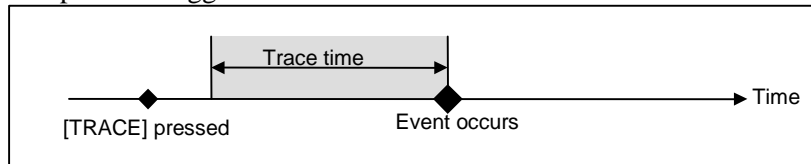

Setting	Trace condition
1	Type 1
2	Type 2
3	Type 3

**- Sampling cycle**

Set the sampling cycle period for waveforms and the sampling cycle for signals as follows:

Type	Setting
Waveform	Multiple of 2 ranging from 2 ms to 4096 ms
Signal	Multiple of 2 ranging from 2 ms to 4096 ms

**- Trace time**

Set the period for tracing data.

The trace time specifies a period of time during which tracing is to be performed for waveforms and signals. If the trace period is insufficient, increase the sampling cycle, or decrease the measurement items. Approximately 32700 points of data can be traced. One point is used for each sampling cycle of one channel. For signal measurement, one channel is used regardless of the number of signals measured at the same time.

When one channel of waveform is traced with a sampling cycle of 4 ms, tracing can be performed for 130 s.

When one channel of waveform is traced with a sampling cycle of 4096 ms, tracing can be performed for 37 hours.

Valid data range: 2 to 133939200

Unit of data: msec

Example of maximum trace time determined by the sampling cycle and the number of channels

Cycle	No. of channels	1ch	4ch + signal
	2 ms		65 s
4 ms		130 s	26 s
8 ms		261 s	52 s
4096 ms		37 hours and 12 minutes	7 hours and 26 minutes

**- Delay time**

When type 3 is selected as the trace condition, the end of tracing can be delayed by a specified time after the occurrence of an event.

Valid data range: 0 to 65528 (in 8-ms increments)

Unit of data: ms

**NOTE**  
If the input numeric value is not a multiple of 8 ms, the value is rounded off to the nearest multiple of 8 ms.

**- Graduation unit on the horizontal axis**

Set an increment per graduation on the horizontal axis.

Valid data range : 1 to 100000000

Unit of data : ms

## Trigger setting

The screenshot shows a menu titled "WAVEFORM DIAGNOSIS (PARAMETER)" with a sub-menu "TRIGGER SETTING". Under "TRIGGER KIND", there are seven options: 1:ALM, 2:SIG ON, 3:SIG OFF, 4:SIG CHG, 5:ALM+SIG ON, 6:ALM+SIG OFF, and 7:ALM+SIG CHG. The number "1" is highlighted in a yellow box next to "1:ALM". Below this, there are input fields for "ALARM KIND" (set to 6), "ALARM No." (set to 452), "AXIS No." (set to 1), and "SIGNAL ADDRESS" (empty).

### - Trigger type

If you specify the occurrence of an event as a trigger when selecting a trace condition in the trace setting of the waveform diagnosis parameter screen (2: AFTER or 3: BEFORE is specified as the trace condition), set the type of the trigger.

If 2 (AFTER) is selected as the trace condition, tracing starts when a set trigger event occurs. If 3 (BEFORE) is selected as the trace condition, tracing ends when the trigger event occurs.

Setting	Trigger type
1	Alarms only
2	A specified signal is turned on.
3	A specified signal is turned off.
4	The status of a specified signal changes.
5	An alarm is issued, or a specified signal is turned on.
6	An alarm is issued, or a specified signal is turned off.
7	An alarm is issued, or the status of a specified signal changes.

### - Alarm type

When the issuance of an alarm is specified as a trigger in the setting of the trigger type (the trigger type is set to 1, 5, 6, or 7), set the type of alarms used as a trigger as listed in the table below. When a particular alarm type is not to be specified, use alarm signal AL as the trigger.

Setting	Alarm type
1	PW alarms
2	IO alarms
3	PS alarms
4	OT alarms
5	OH alarms
6	SV alarms
7	SR alarms
8	MC alarms
9	SP alarms
10	DS alarms
11	IE alarms
12	BG alarms
13	SN alarms
14	EX alarms
15	PC alarms

**- Alarm No.**

If 6 (SV alarms) or 9 (SP alarms) is specified as the alarm type, specify the target alarm number with an integer from 1 to 9999.

To specify all alarm numbers as the alarm target, set -1.

**- Axis No.**

If 6 (SV alarms) or 9 (SP alarms) is specified as the alarm type, specify the target axis for the alarm with an axis number.

To set all axes as the alarm target, set -1.

**NOTE**

For multi-axis control, the axis number must be an absolute axis number instead of a relative axis number in each path.

**- Signal address**

When use of a signal as a trigger is specified for the trigger type (the trigger type is set to 2, 3, 4, 5, 6, or 7), enter the address of the signal used as the trigger.

With a multi-path PMC, an address on a PMC path is set by specifying the path number together with the address.

Example: 2:F0001.1

As shown in the above example, set a PMC path number plus a colon (:) plus an address. With the standard PMC, which has just one path, no path number needs to be specified.

**NOTE**

- 1 For PMC path numbers, refer to "Multi-Path PMC Function" in "FANUC Series 30i-MODEL B PMC Programming Manual" (B-64513EN).
- 2 If the keyboard used does not have the ":" key, use ";" or "/" instead of ":".

**Waveform setting**

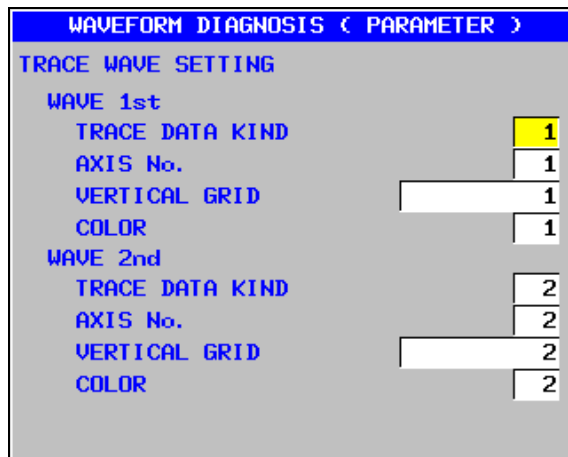



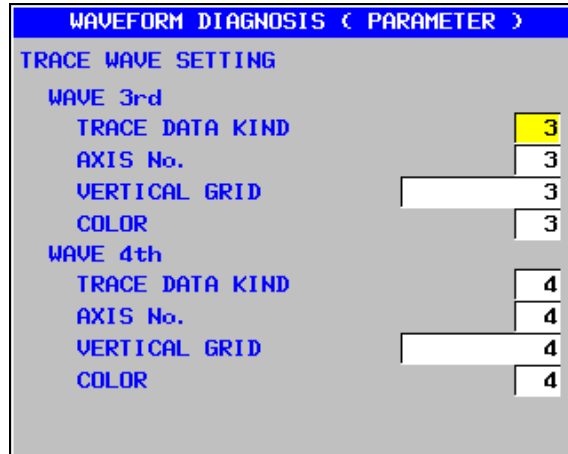

### - Trace data type

Set the type number of data to be traced as listed below:

Setting	Type	Unit
0	(Not traced)	
1	Servo positional deviation	Pulse (detection unit)
2	Servo pulses after distribution	Pulse (detection unit)
3	Servo torque (actual current)	%
4	Servo pulses after acceleration/deceleration	Pulse (detection unit)
5	Actual servo speed	min <sup>-1</sup>
6	Servo current command value	%
7	Servo heat simulation data	%
8	Composite speed of all axes	mm/min or min <sup>-1</sup>
9	Spindle speed	min <sup>-1</sup>
10	Spindle load meter	%
11	Difference in spindle-converted positional deviation during rigid tapping	Pulse (detection unit)

### NOTE

The servo torque (actual current) and current command value are represented by percentages to parameter No. 2086 (rated current).

### - Axis number/path number

Specify an axis number or path number according to the type of data to be traced as follows:

Type	Setting
Servo positional deviation	Controlled axis number (1 to 32)
Servo pulses after distribution	
Servo torque (actual current)	
Servo pulses after acceleration/deceleration	
Actual servo speed	
Servo current command value	
Servo heat simulation data	
Composite speed of all axes	Path number (1 to 10)
Spindle speed	Controlled spindle number (1 to 8)
Spindle load meter	
Difference in spindle-converted positional deviation during rigid tapping	

### NOTE

For multi-axis control, the axis number must be an absolute axis number instead of a relative axis number in each path.

**- Graduation unit on the axis**

Set an increment per graduation on the vertical axis. This setting is valid for servo and spindle data.

Valid data range : 1 to 100000000

**- Waveform color**

Set the number of a color to be used for drawing the waveform as listed below. The numbers represent associated system colors.

Setting	Default drawing color (Associated system color)
0	Black (Data display color)
1	Red (Alarm display color)
2	Green (Title display color)
3	Yellow (Cursor display color)
4	Blue (Subtitle display color)
5	Purple (Input key display color)
6	Blue (Color selection window bar display color)
7	White (Background color for specifiable data)

**Signal setting**

WAVEFORM DIAGNOSIS ( PARAMETER )			
SIGNAL			
SIGNAL	ADDRESS		
1	1: X0000.0	11	1: Y0000.0
2	1: X9999.7	12	1: Y9999.7
3	2: X0000.0	13	
4	2: X9999.7	14	
5	3: X0000.0	15	
6	3: X9999.7	16	
7		17	
8		18	
9		19	
10		20	

WAVEFORM DIAGNOSIS ( PARAMETER )			
SIGNAL			
SIGNAL	ADDRESS		
21	F0000.0	31	G0000.0
22	F9999.7	32	G9999.7
23			
24			
25			
26			
27			
28			
29			
30			

**- Signal setting**

When the ON/OFF state of an input/output signal is to be traced, set the address of the signal.

With a multi-path PMC, an address on a PMC path is set by specifying the path number together with the address.

Example: 2:F0001.1

As shown in the above example, set a PMC path number plus a colon (:) plus an address. With the standard PMC, which has just one path, no path number needs to be specified.

- NOTE**
- 1 For PMC path numbers, refer to "Multi-Path PMC Function" in "PMC Programming Manual" (B-64513EN).
  - 2 If the keyboard used does not have the ":" key, use ";" or "/" instead of ":".
  - 3 For signal data, even when just one signal address is input in an address 1 to 32, one channel is used.
  - 4 When tracing is not performed, enter 0.
  - 5 Up to 32 signals can be measured at the same time.

**Guide to selecting items**

**- Alarm type**

- 1 When the soft key [(OPRT)] is pressed with the cursor positioned at the alarm type in the trigger setting, the soft key [EXPLAIN] appears.



- 2 Pressing the soft key [EXPLAIN] displays a list of alarm types.

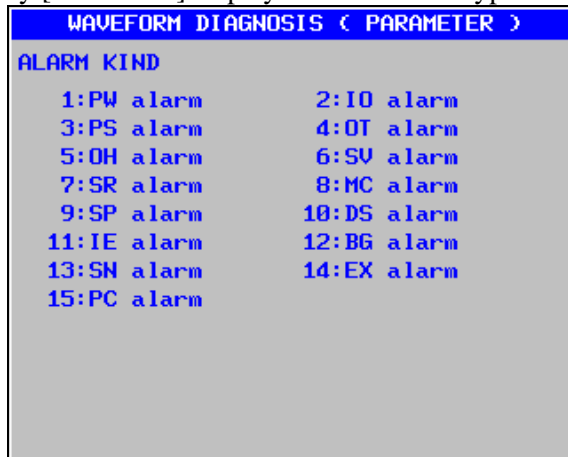

**- Data type**

- 1 When the soft key [(OPRT)] is pressed with the cursor positioned at the trace data type in the trace waveform setting, the soft key [EXPLAIN] appears.
- 2 Pressing the soft key [EXPLAIN] displays a list of trace data types.

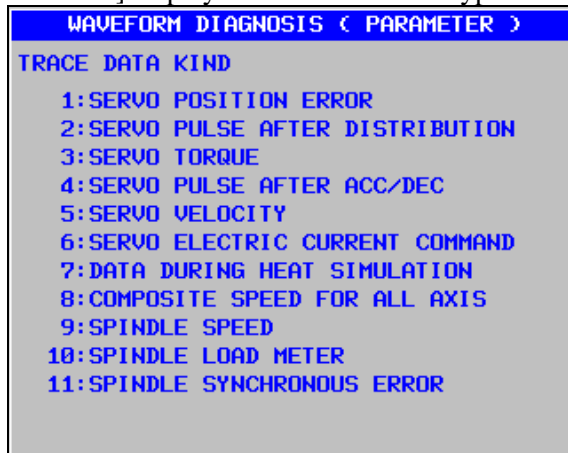

**- Waveform color**

- 1 When the soft key [(OPRT)] is pressed with the cursor positioned at the waveform color in the trace waveform setting, the soft key [EXPLAIN] appears.
- 2 Pressing the soft key [EXPLAIN] displays a list of waveform colors

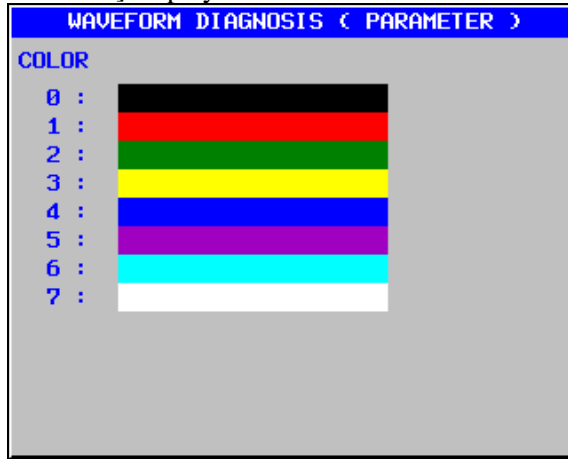

### 1.6.3 Tracing Data

**Starting tracing**

- 1 Display the waveform diagnosis graph screen.
- 2 Press the soft key [TRACE] to start tracing.

"Now Sampling..." appears in the upper part of the screen. When tracing ends, the indication "Now Sampling..." disappears.

Even when the screen display is changed to another screen, tracing continues.

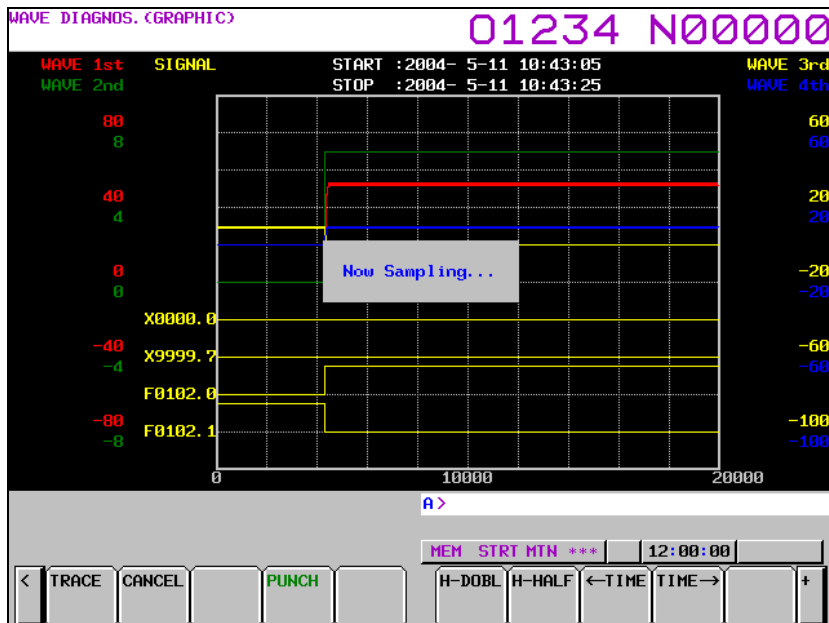

**Canceling tracing**

When the soft key [CANCEL] is pressed during tracing, tracing stops.

## Moving, extending, and reducing a waveform

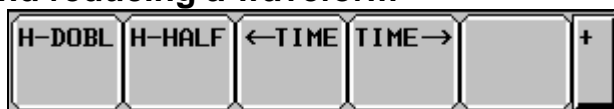

When soft key [H-DOBL] or [H-HALF] is pressed, the length of the time axis on one screen is extended or reduced, respectively.

When a waveform cannot fit in one screen, the time axis can be moved by pressing soft key [←TIME] or [TIME→].

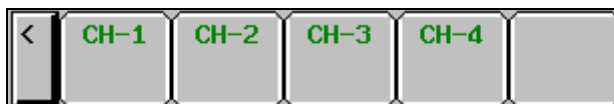

Furthermore, pressing [CH-1], [CH-2], [CH-3], or [CH-4], a submenu appears.

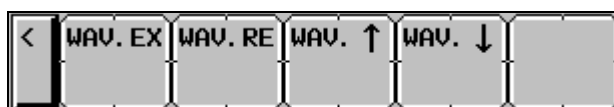

When soft key [WAVE.EX] or [WAVE.RE] is pressed, the length of the time axis on one screen is extended or reduced, respectively. The graduation unit on the horizontal axis, which is a parameter, also changes automatically.

The graduation unit changes from 1 to 2 to 5 to 10 to 20 to 50 to 100, and so on.

When soft key [WAVE.↑] or [WAVE.↓] is pressed, each waveform of servo and spindle data can be moved upward or downward.

## Displaying signal data



Up to 32 signals can be measured at the same time. Up to nine signals can be displayed at the same time if only signal data is displayed, or up to four signals can be displayed if signal data is displayed over waveforms.

When soft key [SIG.↑] or [SIG.↓] is pressed, the currently displayed signals are changed.

### NOTE

Signal data cannot be moved.

## 1.6.4 Outputting Data

Waveform diagnosis data can be output to an input/output device.

### Specifying a format

When outputting data, you can select one of the two formats, which are the FS16*i* compatible format (called the 16 compatible format hereinafter) and the FS30*i* format (called the 30 format hereinafter). If bit 0 (IOF) of parameter No. 10600 is set to 0, the 30 format is selected; if bit 0 (IOF) of parameter No. 10600 is set to 1, the 16 compatible format is selected.

### Output format

Traced data is input or output as a text file with the following format:



(3) Waveform sampling cycle

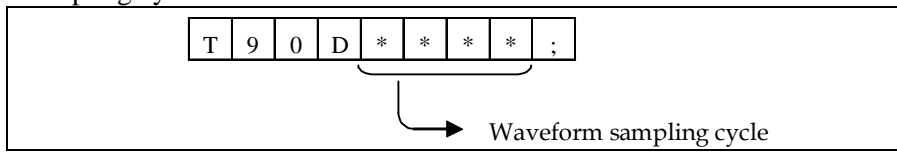

(4) Signal sampling cycle

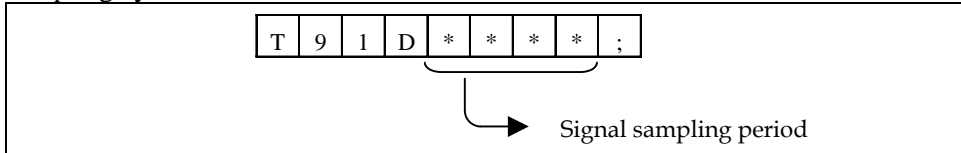

**NOTE**  
The waveform sampling cycle and signal sampling cycle are output only in the 30 format.

(5) Selection items

	Measurement item	Axis No./path No./signal address
P0	Servo positional deviation	Controlled axis number (1 to 32)
P1	Servo pulses after distribution	
P2	Servo torque	
P3	Actual servo speed	
P4	Servo current command value	
P6	Servo pulses after acceleration/deceleration	
P10	Composite speed of all axes	Path number (1 to 10)
P20	Spindle speed	Controlled spindle number
P21	Spindle load meter	
P22	Difference in spindle-conver positional deviation	(1 to 8)
P30	Signal	Signal address

**NOTE**  
Items P6 to P30 are output only in the 30 format.

(6) Waveform diagnosis data

T	6	0	D	*	*	,	*	*	,	~	*	*	.	?
T	6	1	D	*	*	,	*	*	,	~	*	*	.	?
T	6	2	D	*	*	,	*	*	,	~	*	*	.	?
T	6	3	D	*	*	,	*	*	,	~	*	*	.	?
T	6	4	D	*	*	,	*	*	,	~	*	*	.	?
T	6	5	D	*	*	,	*	*	,	~	*	*	.	?
T	7	0	D	*	*	,	*	*	,	~	*	*	.	?
T	7	5	D	*	*	,	*	*	,	~	*	*	.	?
T	8	0	D	*	*	,	*	*	,	~	*	*	.	?
T	8	1	D	*	*	,	*	*	,	~	*	*	.	?
T	8	2	D	*	*	,	*	*	,	~	*	*	.	?
T	9	8	D	*	*	,	*	*	,	~	*	*	.	?

D\*\* ~ \*\* : Waveform diagnosis data × No. of axes/No. of paths/No. of signals

Blocks are output in the following order:

Header	(16 compatible/30 format)
Date and time (start of measurement)	(16 compatible/30 format)
Date and time (end of measurement)	(30 format only)
Waveform measurement period	(30 format only)
Signal measurement period	(30 format only)
Selection item	(16 compatible/30 format)
Waveform diagnosis data	(16 compatible/30 format)

**NOTE**

Signal data of waveform diagnosis data is output after all waveform data is output.



- Sample file

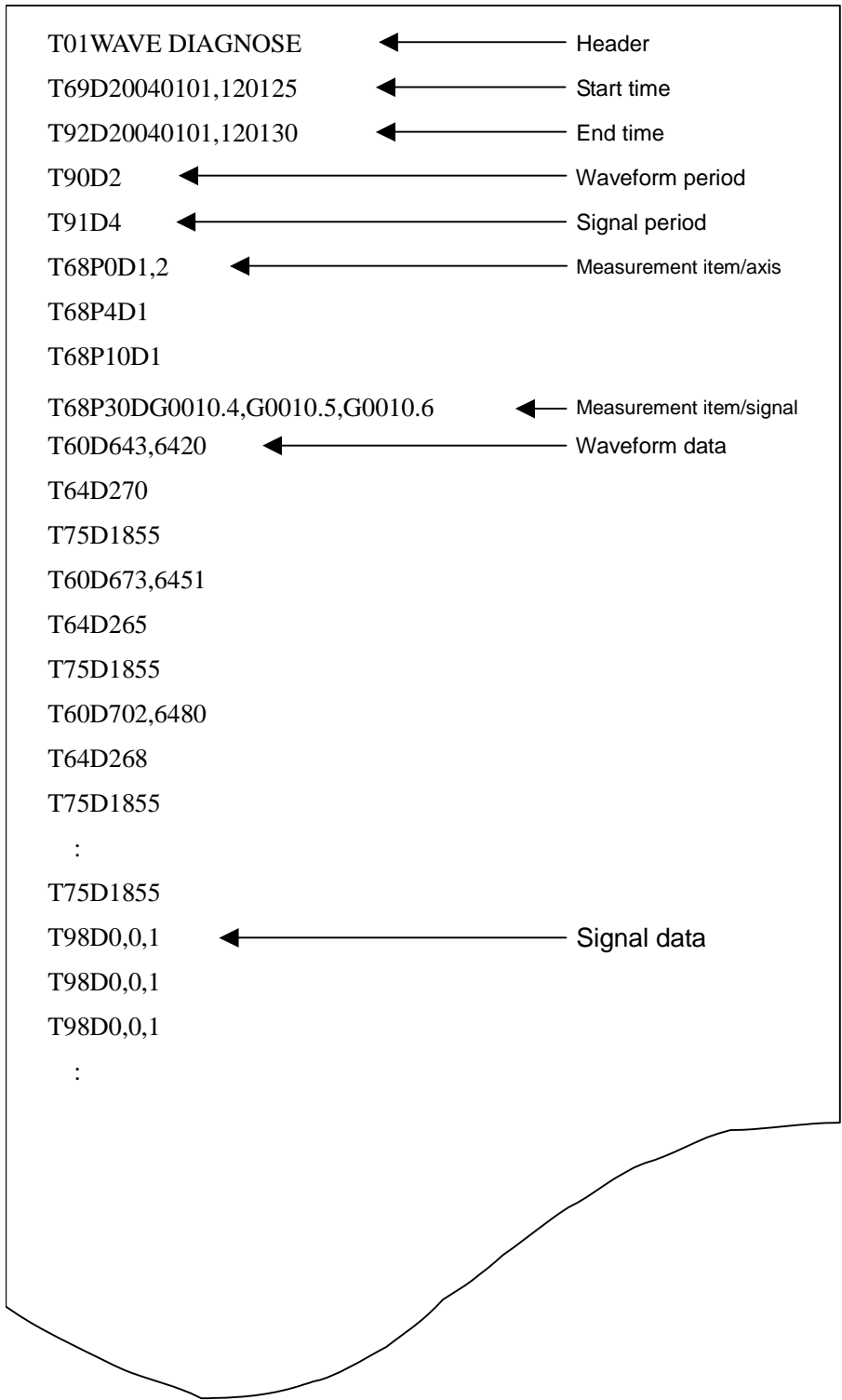

Outputting a file

- 1 Display the waveform diagnosis graph screen.
- 2 When the [(OPRT)] operation soft key is pressed, soft keys are displayed in the following operation selection state:



- 3 Change the mode to the EDIT mode.
- 4 Enter a file name in the key-in buffer, and press the soft key [PUNCH]. If no file name is input, the file name is assumed to be WAVE-DGN.TXT by default.
- 5 Press the soft key [EXEC] shown below to start outputting data:

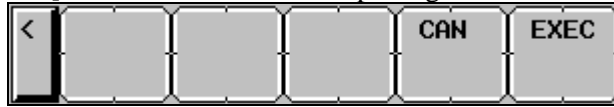

- 6 When data output ends, or when the soft key [CAN] is pressed, the initial operation selection state is restored.

**NOTE**  
While data is being traced, data output is not allowed.

**Parameter**

	#7	#6	#5	#4	#3	#2	#1	#0
10600								IOF



[Input type] Parameter input  
[Type of data] Bit

- #0 **IOF** The output format used for waveform diagnosis is:  
 0: 30i /31i /32i format (30 format).  
 1: 16i /18i /21i format (16 compatible format).

# 1.7 COLOR SETTING SCREEN

On the color setting screen, the colors of the VGA screen can be set.

## 1.7.1 Screen Display

- 1 Press the function key .
- 2 Press the continuous menu key  several times until the soft key [COLOR] is displayed.
- 3 Pressing the soft key [COLOR] displays the color setting screen.

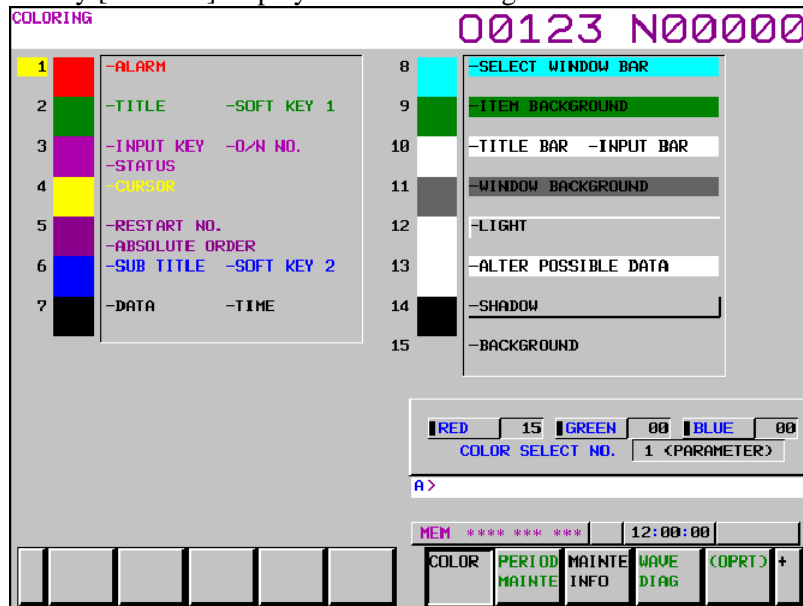

## 1.7.2 Operations for Color Setting

### Modification to color settings (color palette values)

- 1 Pressing the soft key [(OPRT)] displays the following operation soft keys:

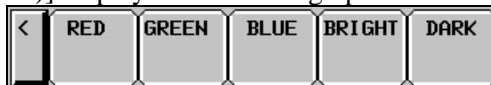

- 2 Move the cursor to a color number whose color palette values are to be modified. The current color palette values of the individual color elements are displayed.
- 3 Select a color element to be modified, with the soft key [RED], [GREEN], or [BLUE]. Multiple color elements can be selected at a time. Each of the soft keys [RED], [GREEN], and [BLUE] toggles between selection and deselection each time the soft key is pressed. (The soft keys [RED], [GREEN], and [BLUE], when not displayed, can be displayed by pressing the rightmost soft key.)
- 4 By pressing the operation soft key [BRIGHT] or [DARK], modify the brightness of the selected color element.

### Storing color settings (color palette values)

Set color palette values can be stored.



- 1 Select a storage area by pressing the [COLOR1], [COLOR2], or [COLOR3] operation soft key.  
 Color 1 Color 1 (standard color) data parameters Nos. 6581 to 6595  
 Color 2 Color 2 data parameters Nos. 10421 to 10435  
 Color 3 Color 3 data parameters Nos. 10461 to 10475

- 2 Press the operation soft key [STORE]. The following operation soft keys are displayed:



- 3 Press the operation soft key [EXEC]. The current color palette values are stored in the selected area. Pressing the operation soft key [CAN] or the leftmost key does not store the current color palette values.

**Calling color settings (color palette values)**



- 1 Select an area for storing color palette values by pressing the operation soft key [COLOR1], [COLOR2], or [COLOR3].  
 (The soft keys [COLOR1], [COLOR2], and [COLOR3], when not displayed, can be displayed by pressing the rightmost soft key.)

- 2 Press the [RECALL] operation soft key. The following operation soft keys are displayed:



- 3 Press the operation soft key [EXEC]. Color palette values are called from the selected area for modification to the color settings. This operation is invalid if no color palette values are stored. Pressing the operation soft key [CANCEL] or the leftmost key does not call color palette values.

**1.7.3 Parameter**

6581	RGB value of color palette 1 for color set 1
6582	RGB value of color palette 2 for color set 1
6583	RGB value of color palette 3 for color set 1
6584	RGB value of color palette 4 for color set 1
6585	RGB value of color palette 5 for color set 1
6586	RGB value of color palette 6 for color set 1
6587	RGB value of color palette 7 for color set 1
6588	RGB value of color palette 8 for color set 1
6589	RGB value of color palette 9 for color set 1
6590	RGB value of color palette 10 for color set 1
6591	RGB value of color palette 11 for color set 1
6592	RGB value of color palette 12 for color set 1
6593	RGB value of color palette 13 for color set 1
6594	RGB value of color palette 14 for color set 1
6595	RGB value of color palette 15 for color set 1

[Data type] 2-word

[Unit of data] rrggbb 6-digit number

(rr: Red data, gg: Green data, bb: Blue data)

When a number shorter than 6 digits is specified, the unspecified higher digit or digits are treated as 0.

[Valid data range] 00 to 15 for each color data (same as the tone level on the color setting screen)

When a value equal to or greater than 16 is specified, the specification of 15 is assumed.

(Example) When setting the color tone level as red = 1, green = 2, and blue = 3, specify "10203".

10421	RGB value of color palette 1 for color set 2
10422	RGB value of color palette 2 for color set 2
10423	RGB value of color palette 3 for color set 2
10424	RGB value of color palette 4 for color set 2
10425	RGB value of color palette 5 for color set 2
10426	RGB value of color palette 6 for color set 2
10427	RGB value of color palette 7 for color set 2
10428	RGB value of color palette 8 for color set 2
10429	RGB value of color palette 9 for color set 2
10430	RGB value of color palette 10 for color set 2
10431	RGB value of color palette 11 for color set 2
10432	RGB value of color palette 12 for color set 2
10433	RGB value of color palette 13 for color set 2
10434	RGB value of color palette 14 for color set 2
10435	RGB value of color palette 15 for color set 2

[Data type] 2-word

[Unit of data] rrggbb 6-digit number

(rr: Red data, gg: Green data, bb: Blue data)

When a number shorter than 6 digits is specified, the unspecified higher digit or digits are treated as 0.

[Valid data range] 00 to 15 for each color data (same as the tone level on the color setting screen)

When a value equal to or greater than 16 is specified, the specification of 15 is assumed.

(Example) When setting the color tone level as red = 1, green = 2, and blue = 3, specify "10203".

10461	RGB value of color palette 1 for color set 3
10462	RGB value of color palette 2 for color set 3
10463	RGB value of color palette 3 for color set 3
10464	RGB value of color palette 4 for color set 3
10465	RGB value of color palette 5 for color set 3
10466	RGB value of color palette 6 for color set 3
10467	RGB value of color palette 7 for color set 3
10468	RGB value of color palette 8 for color set 3
10469	RGB value of color palette 9 for color set 3

10470	RGB value of color palette 10 for color set 3
10471	RGB value of color palette 11 for color set 3
10472	RGB value of color palette 12 for color set 3
10473	RGB value of color palette 13 for color set 3
10474	RGB value of color palette 14 for color set 3
10475	RGB value of color palette 15 for color set 3

[Data type] 2-word

[Unit of data] rrggbb 6-digit number

(rr: Red data, gg: Green data, bb: Blue data)



When a number shorter than 6 digits is specified, the unspecified higher digit or digits are treated as 0.

[Valid data range] 00 to 15 for each color data (same as the tone level on the color setting screen)

When a value equal to or greater than 16 is specified, the specification of 15 is assumed.

[Example] When setting the color tone level as red = 1, green = 2, and blue = 3, specify "10203".

## 1.7.4 Notes

- (1) Immediately after the power is turned on, color 1 is used as the screen color.  
If no color palette values are stored in color 1, the FANUC standard color is used for display.
- (2) Do not modify the parameters of the standard color data by direct MDI key input. When modifying the parameters of the RGB value, be sure to perform a storage operation on the color setting screen.
- (3) If the screen display becomes invisible because an incorrect value is input in an RGB value parameter, turn off the power then turn on the power again while holding down the  +  keys. All stored color data is cleared, and the screen is displayed in the FANUC standard color. This operation, however, clears all contents of the memory including parameters and programs. Take special care when performing this operation.

## 1.8 POWER MATE CNC MANAGER FUNCTION



When the I/O Link Option for the FANUC servo unit  $\beta i$  series (called I/O Link  $\beta i$  below) is used for CNC additional axes (slaves), the Power Mate CNC manager function can be used to display and set up various types of data of these slaves on the CNC.

The Power Mate CNC manager function enables the following display and setting operations:

- (1) Current position display (absolute/machine coordinates)
- (2) Parameter display and setting
- (3) Alarm display
- (4) Diagnosis data display
- (5) System configuration screen display



Up to eight slaves can be connected to each I/O Link channel.

## 1.8.1 Screen Display

- 1 Press the function key .
- 2 Press the continuous menu key  several times until the soft key [P.MATE MGR.] is displayed.
 

- 3 Pressing the soft key [P.MATE MGR.] displays the absolute coordinate screen, which is the initial screen of the Power Mate CNC manager. On this screen, you can select each of the following items by pressing the corresponding soft key:
  - ABS: Absolute coordinate display
  - MACHIN: Machine coordinate display
  - PARAM: Parameter screen
  - MSG: Alarm list
  - DGNOS: Diagnosis screen
  - SYSTEM: System information

To select another function after one of the functions listed above is selected, press the return menu key  until the soft keys appear as shown above. Then, select the desired function.
- 4 Terminating the Power Mate CNC manager function  
 Press the return menu key once or twice. The soft keys of the CNC system appear, and the Power Mate CNC manager terminates.

Alternatively, you can select another function by pressing an MDI function key (, , , etc.) to terminate the Power Mate CNC manager function.

### Selecting a slave

When slaves are connected to multiple I/O Link channels, pressing soft key [NEXT CH.] or [PREV. CH.] displayed by pressing the soft key [(OPRT)] changes the displayed channel.

In the upper section of the screen, the following information items are displayed for the connected slaves (up to eight slaves):

- I/O Link group number (0 to 15)
- Alarm status

The cursor is positioned at the number of the slave for which to display information (active slave). When multiple slaves are connected, pressing the soft key [NEXT SLAVE] or [PREV. SLAVE] changes the active slave.

You can display the slave status and select a slave on any screen of the Power Mate CNC manager function.

### Current position display screen

The current position display screen displays the current position and actual feedrate of the slave.

The following current position data is displayed:

- Absolute coordinate (current position in the absolute coordinate system)
- Machine coordinate (current position in the machine coordinate system)

#### - Display method

Press soft key [ABS] or [MACHIN] to display the absolute coordinate screen or machine coordinate screen, respectively.

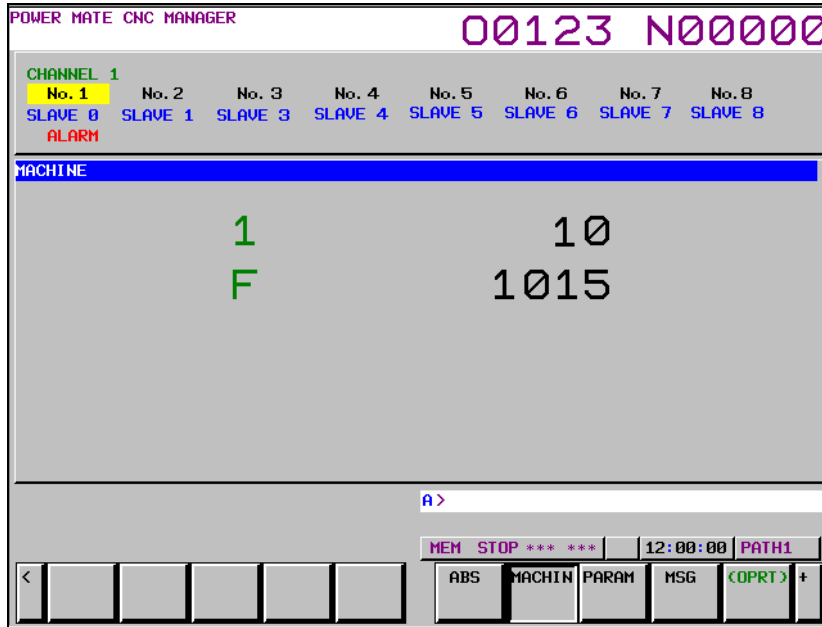

Power Mate CNC manager: Machine coordinate screen

### Axis name display

You can change the axis name by setting it in the I/O Link  $\beta i$  parameters Nos. 0024 and 0025. Up to two characters can be set. (Use the ASCII codes of 0 to 9 and/or A to Z). When no axis name is set or the setting data is invalid, the axis name is set to 1.

This axis name is used only for position display of the Power Mate CNC manager function and irrelevant to the controlled axis on the CNC.

### Parameter screen

The parameters required for the functions of the slave must be specified in advance.

Press soft key [PARAM] to display the parameter screen.

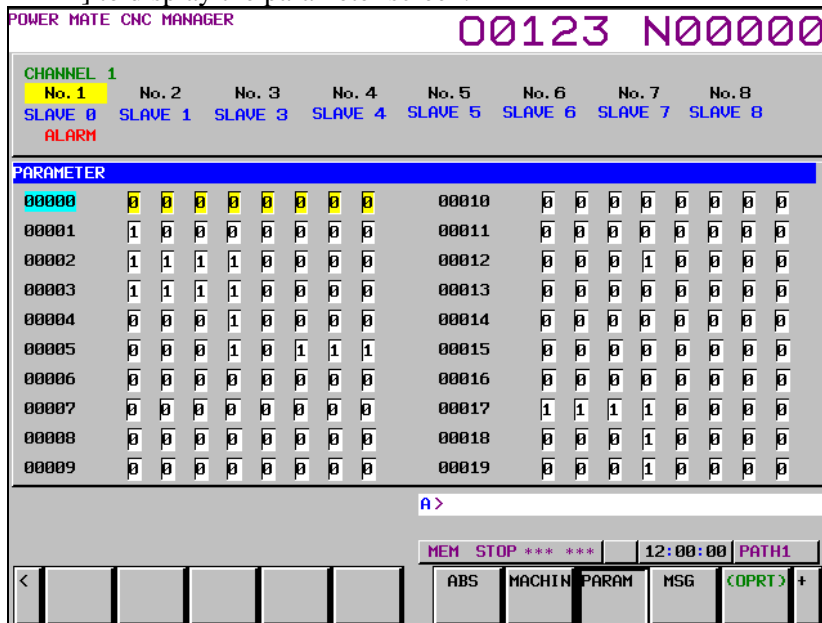

This screen displays only the bit and decimal data. For details of the parameters, refer to FANUC SERVO MOTOR  $\beta i$  series I/O Link Option Maintenance Manual.



- Selecting and searching for a parameter
  - 1 First, select the active slave.
  - 2 Press the soft key [(OPRT)]. The following soft keys appear:

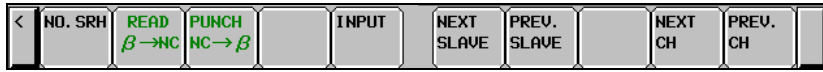

- 3 Enter a parameter number and press the soft key [NO. SRH]. The search starts. You can also select a desired parameter number by pressing the cursor keys and page keys and moving the cursor.

- Setting a parameter
 

You can directly set an I/O Link  $\beta i$  parameter of the slave from the CNC.

  - 1 Select a desired parameter using either of the above methods.
  - 2 Press the soft key [(OPRT)]. The following soft keys appear:



- 3 Enter setting data.
- 4 Press the soft key [INPUT] or MDI key .

**Alarm screen**

If an alarm is issued for the slave, “ALARM” is displayed in the slave status field in the upper section of the screen.  
 At this time, you can display the alarm screen to check the details of the alarm.  
 Up to 40 alarm codes are displayed on the screen.  
 For details of the alarms, refer to FANUC SERVO MOTOR  $\beta i$  series I/O Link Option Maintenance Manual.

**- Display method**

Press the soft key [MSG]. On the screen, only error codes are displayed.

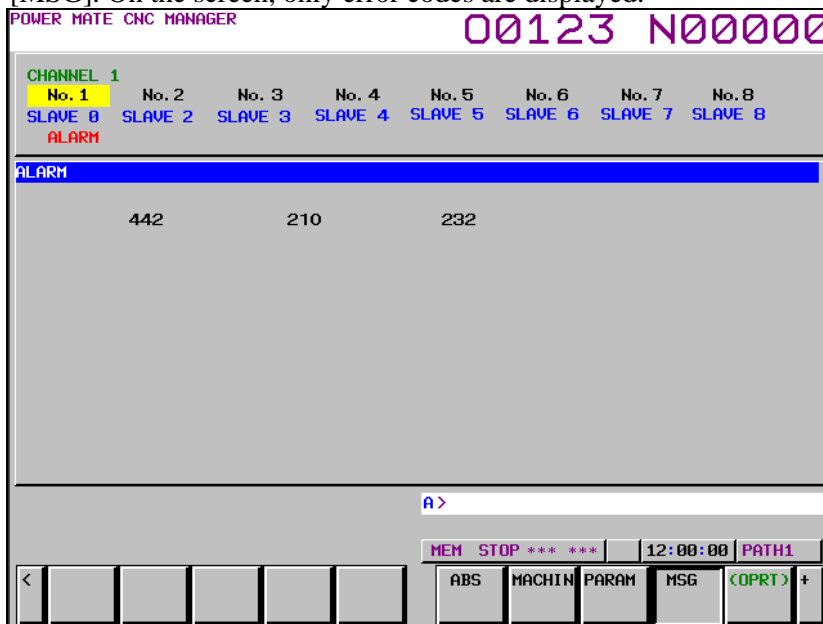

Example of displaying alarms for I/O Link  $\beta i$  of slave 0

### Diagnosis screen

The diagnosis screen displays diagnosis information of the slave.

Diagnosis data is displayed in bit or integer (decimal) representation. For details of diagnosis data, refer to FANUC SERVO MOTOR  $\beta$ i series I/O Link Option Maintenance Manual.

**- Display method**

- 1 Press the continuous menu key .
- 2 Press soft key [DGNOS] to display the diagnosis screen.

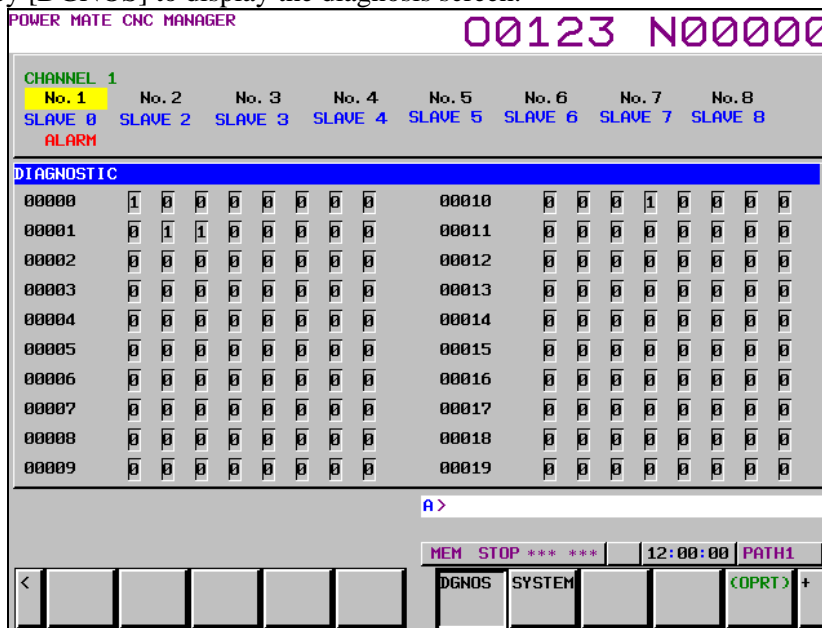



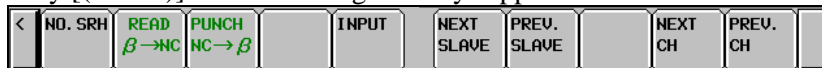

### Searching for diagnosis data

- 1 First, select the active slave.
- 2 Press the soft key [(OPRT)]. The following soft keys appear:



- 3 Enter a diagnosis number and press the soft key [NO. SRH]. The search starts.

You can also select a desired parameter number by pressing the cursor keys   and page

keys   and moving the cursor.

### System configuration screen

The system configuration screen displays information on the system software of slaves.

**- Display method**

- 1 Press the continuous menu key .
- 2 Press the soft key [SYSTEM] to select the system configuration screen.

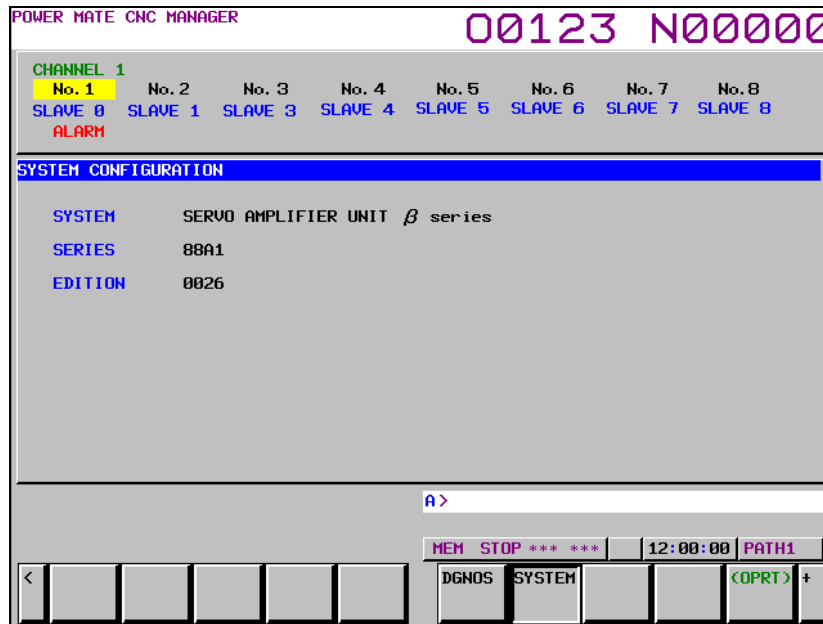

Series and edition of the I/O Link βi system software

## 1.8.2 Inputting and Outputting Parameters

### Outputting parameters

Parameters are output to the CNC memory or a memory card as a data file in the program format. Set the first registration program number in parameter No. 8760. For each slave, program with a predetermined number is created.

When parameters are output to the CNC memory, a program with the specified program number is created.

When parameters are output to a memory card, a file is created, of which file name consists of the specified program number and an extension PMM.

Program number = setting-of-parameter (parameter No. 8760) + (m - 1) × 100 + n × 10

m: Channel number (1 to 4)

n: Group number

Example: When parameter No. 8760 is set to 8000

Channel 1 (I/O Link β: Group 0)

$$8000 + 0 * 100 + 0 * 10 = 8000$$

Channel 2 (I/O Link β: Group 1)

$$8000 + 1 * 100 + 1 * 10 = 8110$$

Channel 3 (I/O Link β: Group 2)

$$8000 + 2 * 100 + 2 * 10 = 8220$$

Channel 4 (I/O Link β: Group 3)

$$8000 + 3 * 100 + 3 * 10 = 8330$$

The group number is the slave number displayed in the slave status field in the upper section of the screen in reverse video.

When bit 3 (PMO) of parameter No. 0961 is set to 1, the numbers of the parameters to be output can be set only with a group number.

Select a desired input device using bits 1 (MD1) and 2 (MD2) of parameter No. 0960.

Connect a memory card or check the unused area of the CNC memory, then follow the steps below:

- 1 For multi-path control, display the Power Mate CNC manager screen from the screen for path 1.
- 2 Select the active slave.

Press the soft key [(OPRT)]. The following soft keys appear:



3 Press the soft key [READ]. The following soft keys appear:



4 Press the soft key [EXEC].  
During input, “INPUT” blinks in the message field.

**NOTE**

- 1 Parameters can be saved in other than the MEM mode or in the emergency stop status.
- 2 To save parameters in a memory card, if a file with the same name is found in the memory card, the parameters cannot be saved. Delete the file from the memory card or change the file name by setting parameter No. 8760.  
To save parameters in a program area, save operation is performed according to the setting of bit 2 (REP) of parameter No. 3201.

**Inputting parameters**

A data file of parameters output to the CNC memory or a memory card as a program is input to the slave determined by the program number. The program number and memory device are determined as described in “Outputting parameters.”

- 1 For multi-path control, display the Power Mate CNC manager screen from the screen for path 1.
- 2 Select the active slave.
- 3 Press the soft key [(OPRT)]. The following soft keys appear:



4 Press the soft key [PUNCH]. The following soft keys appear:



5 Press the soft key [EXEC].  
During output, “OUTPUT” blinks in the message field.

**NOTE**

- 1 Parameters can be input in other than the MEM mode or in the emergency stop status.
- 2 For multi-path control, parameters can be input and output only using the Power Mate CNC manager screen for path 1. They can only be input from and output to the CNC memory for path 1.

**1.8.3 Parameters**

	#7	#6	#5	#4	#3	#2	#1	#0
0960				PPE	PMN	MD2	MD1	

[Input type] Setting input  
[Data type] Bit path

**#1 MD1**

**#2 MD2** The slave parameters are input from and output to either of the following devices:

Parameter MD2	Parameter MD1	I/O destination
0	0	Program memory
0	1	Memory card

**#3 PMN** The Power Mate CNC manager function is:

0: Enabled.

1: Disabled. (Communication with the slave is not performed.)

**#4 PPE** Setting slave parameters using the Power Mate CNC manager:

0: Can always be performed regardless of the setting of PWE.

1: Follows the setting of PWE.

	#7	#6	#5	#4	#3	#2	#1	#0
0961					PMO			

[Input type] Parameter input

[Data type] Bit

**#3 PMO** The O number of a program for saving and restoring the I/O LINK  $\beta$  parameter is set based on:

0: Group number and channel number

1: Group number only

8760	Program number of data input/output (Power Mate CNC manager)
------	--

[Input type] Setting input

[Data type] 2-word path

[Valid data range] 0 to 99999999

This parameter sets the program numbers of programs to be used for inputting and outputting slave data (parameters) when the Power Mate CNC manager function is used.

For a slave specified with I/O LINK channel m and group n, the following program number is used:

Setting +  $(m - 1) \times 100 + n \times 10$

If the setting is 0, the parameters of the slave specified with channel 1 and group 0 cannot be input from or output to the CNC memory because the program number is set to 0. The parameters can be input from and output to a memory card.

(Set a value with which any used program number does not exceed 99999999.)

## Warning

If an alarm is issued for the Power Mate CNC manager, a warning message is displayed.

Message	Description
DATA ERROR	An attempt was made to execute [PUNCH] (NC → $\beta$ ) for a program not found in the program area.
WRITE PROTECTED	An attempt was made to execute [READ] ( $\beta$ → NC) for a program area when the memory protection signal (KEY) is off.

Message	Description
EDIT REJECTED	<p>An attempt was made to execute [READ] (<math>\beta \rightarrow \text{NC}</math>) when the program area already contained a program with the same name as that to be created by executing [READ] (<math>\beta \rightarrow \text{NC}</math>).</p> <p>An attempt was made to execute [READ] (<math>\beta \rightarrow \text{NC}</math>) when the number of the program to be created by executing [READ] (<math>\beta \rightarrow \text{NC}</math>) was selected.</p> <p>An attempt was made to execute [READ] (<math>\beta \rightarrow \text{NC}</math>) when bit 0 (TVC) of CNC parameter No. 0000 was set to 1. (Parameters Nos. 0000 to 0019 are output, but parameter No. 0020 and subsequent parameters are not output.)</p> <p>An attempt was made to execute [PUNCH] (<math>\text{NC} \rightarrow \beta</math>) when a memory card did not contain any program for which [PUNCH] (<math>\text{NC} \rightarrow \beta</math>) could be executed.</p> <p>An attempt was made to execute [READ] (<math>\beta \rightarrow \text{NC}</math>) for a protected memory card.</p>
NO MORE SPACE	An attempt was made to execute [READ] ( $\beta \rightarrow \text{NC}$ ) when the program area did not have enough unused space.
FORMAT ERROR	Data other than digits, signs, CAN, and INPUT was entered as the setting of a parameter.
TOO MANY FIGURES	Data consisting of 9 or more digits was entered for a bit-type parameter.
DATA IS OUT OF RANGE	The setting exceeds the valid data range.

## 1.8.4 Notes

### - Connecting an I/O Link

When I/O Link  $\beta i$  is used as a slave of an I/O Link, the CNC assigns I/O addresses. The slave data is input and output in 16-byte units. Therefore, be sure to specify 128 as the number of input/output points.

Up to eight slaves can be connected.

The module name is OC021 (16-bit input) or OC020 (16-byte output).

BASE is always 0 and SLOT is always 1.

### - Function of ignoring the Power Mate CNC manager

After setting and checking data required for each slave connected, you can stop communication with the Power Mate CNC manager function to send a command from the CNC ladder to the slave.

When bit 3 (PMN) of parameter No. 960 is set to 1, communication between the CNC and the slave via the I/O Link is all open to the ladder. While this bit is 1, the Power Mate CNC manager function does not operate.

### - Data protection key

When the program data protection key of the CNC is on, no parameters can be input to the CNC program memory.

## 1.9 SERVO GUIDE MATE

The servo guide mate enables various types of data related to the servo motor and spindle motor to be displayed on the screen in the form of graphs. This allows you to readily measure the machine precision, thereby making it easy to grasp changes in precision resulting from the aging process, an earthquake, or collision of the machine.

### Overview

Set up as outlined in Fig. 1.9 (a), the servo guide mate displays graphs representing the feedback data related to the servo motor and spindle motor that are controlled through the execution of the program. It features such functions as drawing graphs representing chronological changes in data and the motor path, as well as displaying an enlarged view of error associated with the circular operation.

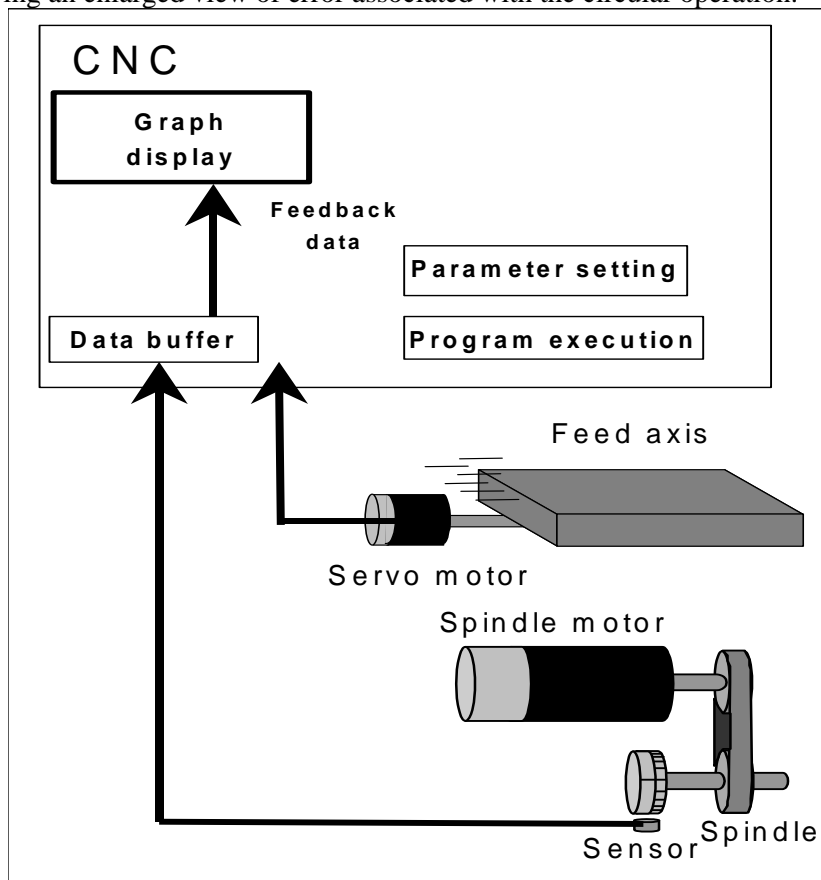

Fig. 1.9 (a) Outline of the servo guide mate setup

### 1.9.1 Wave Display

The wave display function can acquire various types of data related to the servo motor and spindle motor and display graphs in several different drawing modes for the analysis of the measurement data. A graph is made up of the two elements described below. To display a graph, therefore, operations for the wave display need to be set, in addition to the measurement data.

- 1 Measurement data  
This refers to raw data, such as position and torque, acquired from the CNC on a per-channel basis.
- 2 Operations  
This collectively refers to the results of operations performed for measurement data. A graph cannot be displayed unless necessary operations are set.

This denotes that the following relationship holds true:

Wave display (graph display) = measurement data + operations

In the remainder of this chapter, the term channel (CH) is used to refer to a specific set of measurement data and the term draw to refer to a specific displayed wave.

CH1 : Measurement data 1

Draw3 : Display waveform 3

A conceptual diagram of the wave display is shown Fig. 1.9 (b).

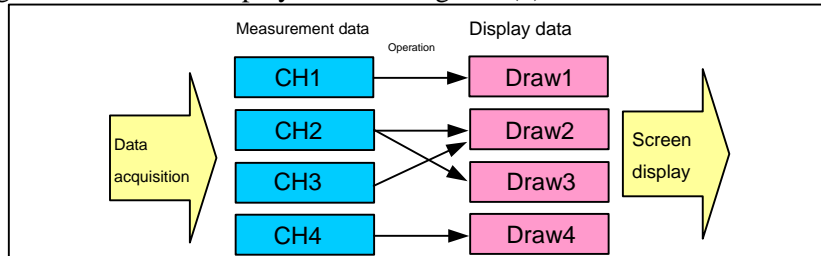

Fig. 1.9 (b)

Measurements of both the servo motor and spindle motor can be made for up to four channels simultaneously. Also, data can be measured at up to 10000 points per measurement item.

The following five drawing modes are available.

- 1 Y-time graph  
This mode displays wave data along the time axis, as by an oscilloscope.
- 2 XY graph  
This mode provides a 2-dimensional path display using 2-axis data.
- 3 Circle graph  
This mode displays an enlarged view of the path deviation from the specified circle arising during circular cutting.
- 4 Fourier graph  
This mode displays the frequency spectrum by performing digital Fourier conversion for the range of data displayed by the Y-time graph.
- 5 Bode graph  
This mode displays a Bode diagram in the form of single logarithm graph for the horizontal axis.

## Note

- Axis number

### NOTE

For multi-axis control, the axis number must be an absolute axis number instead of a relative axis number in each path.



### 1.9.1.1 Y-time graph

The Y-time graph displays wave data for the measurement data along the time axis, as by an oscilloscope. Up to four draws can be displayed at a time.

## Displaying and setting the Y-time graph

### Procedure

The procedure for displaying the measurement data is described below.

- 1 Press the  function key.
- 2 Press the continuous menu key  several times until [SERVO GUIDE MATE] is displayed.
- 3 Click the soft key [SERVO GUIDE MATE].
- 4 Click the soft key [Y-TIME].

The wave display screen is displayed as shown Fig. 1.9.1.1 (a).



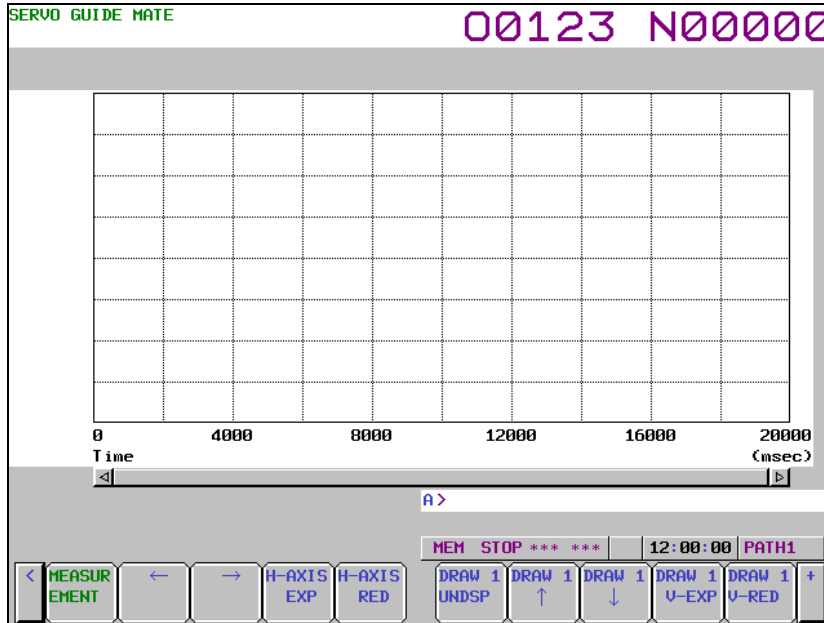

Fig. 1.9.1.1 (a)

- 5 Click the soft key[MEASUREMENT].
- 6 Click the soft key[DATA IN].
- 7 Click the soft key[SAMPLING].

The data-in screen is displayed as shown Fig. 1.9.1.1 (b).

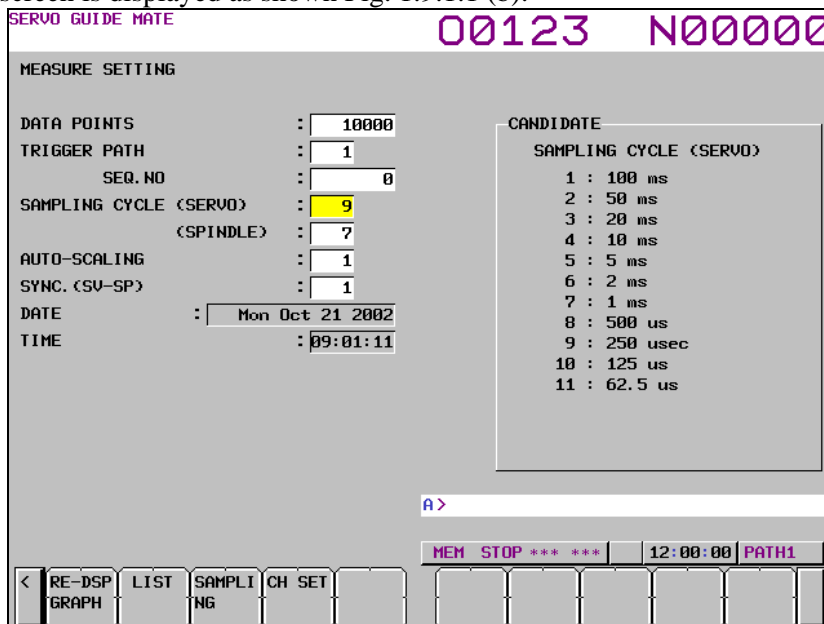





Fig. 1.9.1.1 (b)

- 8 Move the cursor to the parameter you want to set, by pressing the cursor key.
- 9 Enter data and then press the  key.
- 10 Repeat steps 8 and 9 until you set all the parameters.
- 11 Click the soft key [SET CHANNEL].

The channel setting screen is displayed as shown Fig. 1.9.1.1 (c).

To set any channel other than the one currently displayed, display the setting screen for the desired channel by pressing the  or  key.

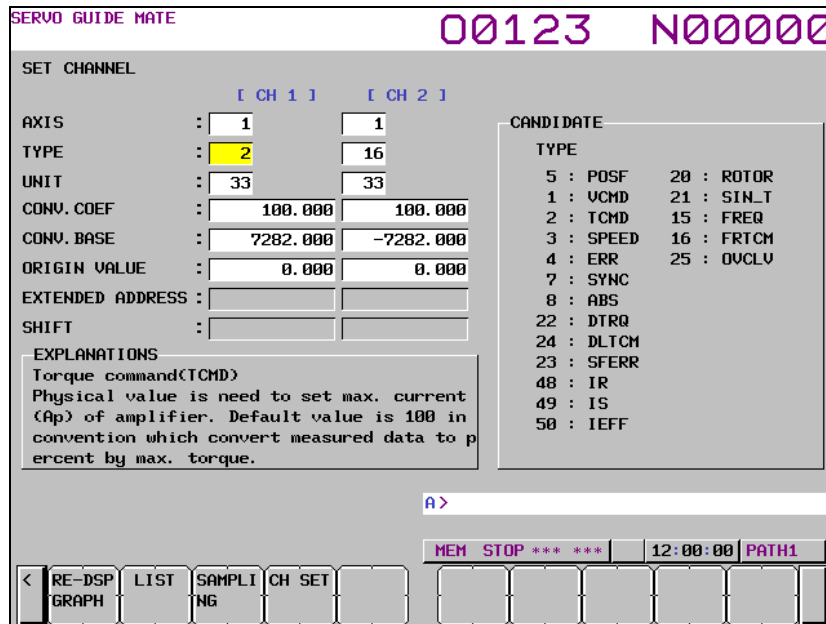



Fig. 1.9.1.1 (c)

12 Move the cursor to the parameter you want to set, by pressing the cursor key.



13 Enter data and the press the  key.

14 Repeat steps 12 and 13 until you set all the parameters.

15 Click the soft key [RE-DSPGRAPH].

16 Click the soft key [OPERATION & GRAPH].

The operation and graph setting screen is displayed as shown Fig. 1.9.1.1 (d).

To set any draw other than the one currently displayed, display the setting screen for the desired draw by pressing the  or  key.

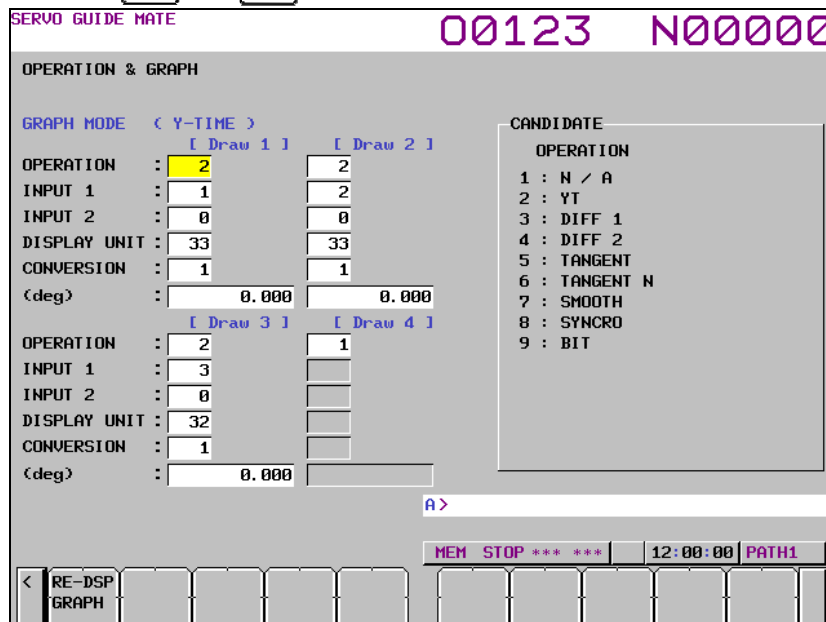



Fig. 1.9.1.1 (d)

17 Move the cursor to the parameter you want to set, by pressing the cursor key.

18 Enter data and the press the  key.

19 Repeat steps 17 and 18 until you set all the parameters.

20 Click the soft key [RE-DSPGRAPH].

- 21 Click the soft key [SCALE SET].  
The scale setting screen is displayed as shown Fig. 1.9.1.1 (e).

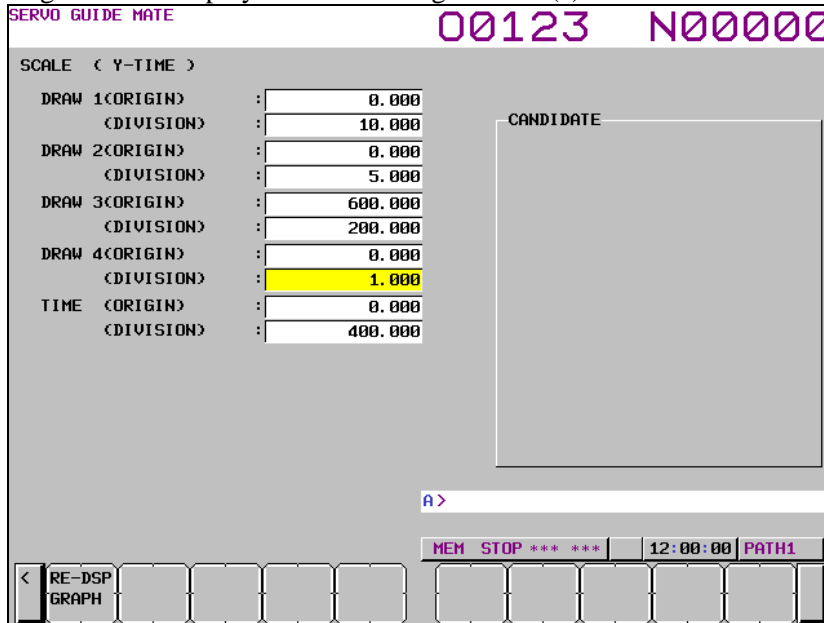



Fig. 1.9.1.1 (e)

- 22 Move the cursor to the parameter you want to set, by pressing the cursor key.
- 23 Enter data and the press the  key.
- 24 Repeat steps 22 and 23 until you set all the parameters.
- 25 Click the soft key [RE-DSPGRAPH].
- 26 Click the soft key [MEASUREMENT].
- 27 Click the soft key [START].
- 28 Start the automatic or manual operation.
- 29 When the measurement is completed, the wave display screen is displayed as shown Fig. 1.9.1.1 (f).

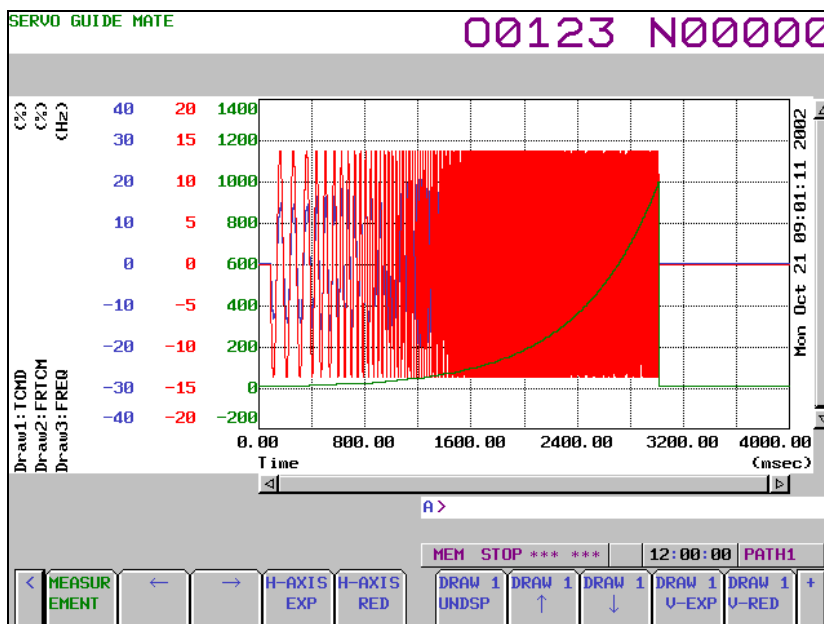



Fig. 1.9.1.1 (f)

**- Changing the operation and graph setting screen**

The procedure for changing the operation and graph setting screen as necessary is described below.

- 1 Click the soft key [OPERATION & GRAPH].  
The operation and graph setting screen is displayed as shown Fig. 1.9.1.1 (g).  
To set any draw other than the one currently displayed, display the setting screen for the desired draw by pressing the  or  key.

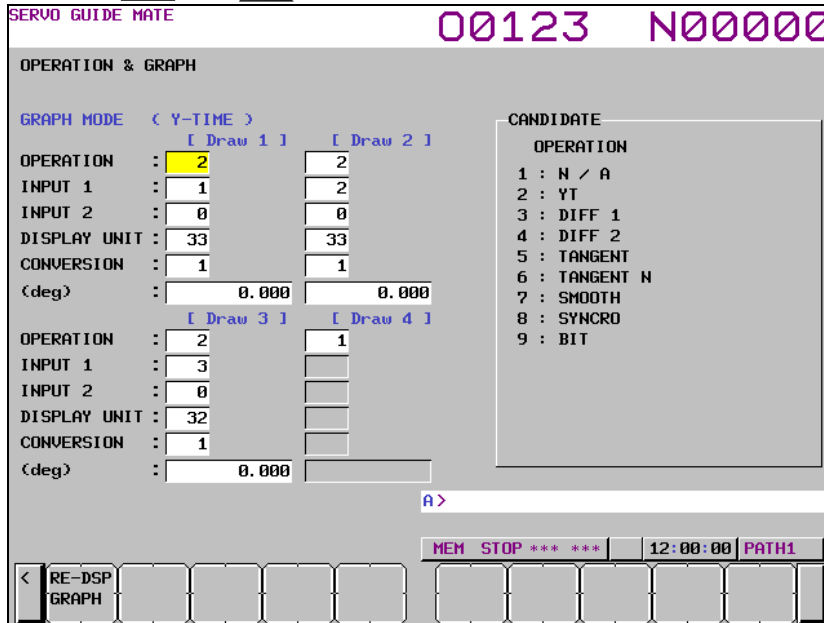



Fig. 1.9.1.1 (g)

- 2 Move the cursor to the parameter you want to set, by pressing the cursor key.
- 3 Enter data and the press the  key.
- 4 Repeat steps 2 and 3 until you set all the parameters.
- 5 Click the soft key [RE-DSPGRAPH].  
Based on the new operation and graph settings, the wave display screen is displayed as shown Fig. 1.9.1.1 (h).

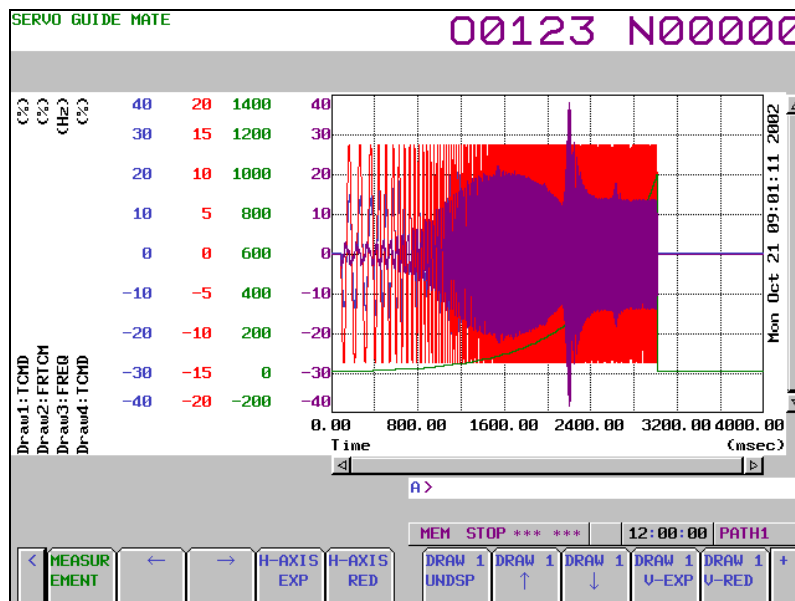

Fig. 1.9.1.1 (h)

**- Changing the scale screen**

The procedure for changing the scale settings as necessary is described below.

- 1 Click the soft key [SCALE SET].  
The scale setting screen is displayed as shown Fig. 1.9.1.1 (i).

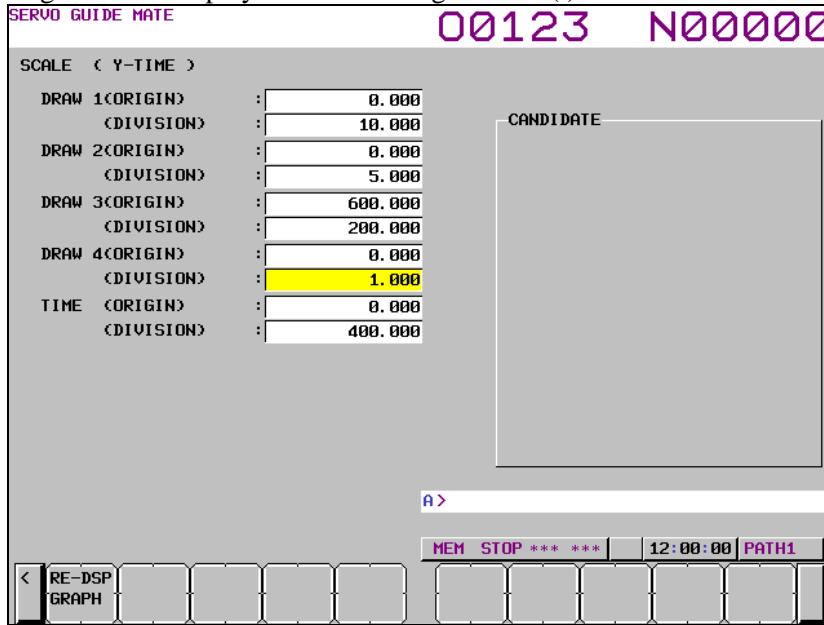



Fig. 1.9.1.1 (i)

- 2 Move the cursor to the parameter you want to set, by pressing the cursor key.
- 3 Enter data and the press the  key.
- 4 Repeat steps 2 and 3 until you set all the parameters.
- 5 Click the soft key [RE-DSPGRAPH].  
Based on the new scale settings, the wave display screen is displayed as shown Fig. 1.9.1.1 (j).

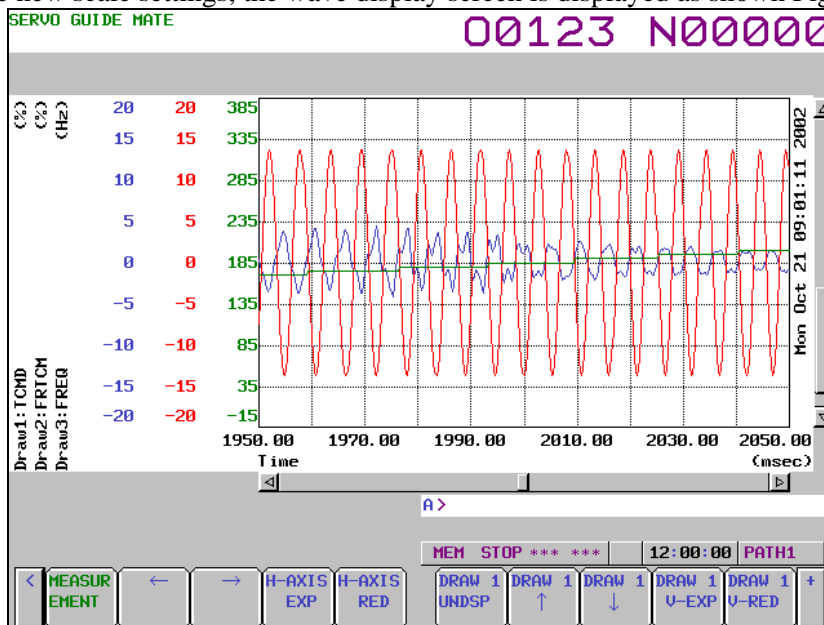

Fig. 1.9.1.1 (j)

**- Manipulating the Y-time graph**

By clicking the following soft keys, you can perform the operations corresponding to them.

- [MEASUREMENT] : Performs a measurement-related operation.
- [←] : Shifts the time axis to the right.
- [→] : Shifts the time axis to the left.
- [H-AXIS EXP] : Expands the time axis.

[H-AXIS RED]	: Reduces the time axis.
[DRAW 1UNDSP]	: Sets whether or not to display Draw 1.
[DRAW 1 ↑]	: Shifts Draw 1 downward.
[DRAW 1 ↓]	: Shifts Draw 1 upward.
[DRAW 1 V-EXP]	: Expands Draw 1.
[DRAW 1 V-RED]	: Reduces Draw 1.
[DRAW 2UNDSP]	: Sets whether or not to display Draw 2.
[DRAW 2 ↑]	: Shifts Draw 2 downward.
[DRAW 2 ↓]	: Shifts Draw 2 upward.
[DRAW 2 V-EXP]	: Expands Draw 2.
[DRAW 2 V-RED]	: Reduces Draw 2.
[DRAW 3UNDSP]	: Sets whether or not to display Draw 3.
[DRAW 3 ↑]	: Shifts Draw 3 downward.
[DRAW 3 ↓]	: Shifts Draw 3 upward.
[DRAW 3 V-EXP]	: Expands Draw 3.
[DRAW 3 V-RED]	: Reduces Draw 3.
[DRAW 4UNDSP]	: Sets whether or not to display Draw 4.
[DRAW 4 ↑]	: Shifts Draw 4 downward.
[DRAW 4 ↓]	: Shifts Draw 4 upward.
[DRAW 4 V-EXP]	: Expands Draw 4.
[DRAW 4 V-RED]	: Reduces Draw 4.
[AUTO SCALE]	: Enables auto scaling.
[V-AXIS EXP]	: Expands all draws.
[V-AXIS RED]	: Reduces all draws.
[OPE/G SET]	: Sets operations and graphs.
[SCALE SET]	: Sets scales.
[COM1 INPUT]	: Inputs comment 1.
[COM2 INPUT]	: Inputs comment 2.
[XY]	: Switches to the XY graph.
[CIRCLE]	: Switches to the Circle graph.
[FOURIER]	: Switches to the Fourier graph.
[BODE]	: Switches to the Bode graph.

### - Performing measurement

When you click the soft key [MEASUREMENT], you can perform the operations corresponding to the menu items that follow.



[START]	: Starts measurement.
[ORIGIN]	: Sets the origin value.
[STOP]	: Stops measurement.
[DATA IN]	: Specifies measurement-related settings.

### - Changing measurement settings

1 When you click the soft key [MEASUREMENT] and then the soft key [DATA IN], you can perform the operations corresponding to the menu items that follow.

2 Click the soft key [LIST].

The list screen is displayed as shown Fig. 1.9.1.1 (k).

To display any channel other than the one currently displayed, display the list screen for the desired channel by pressing the  or  key.

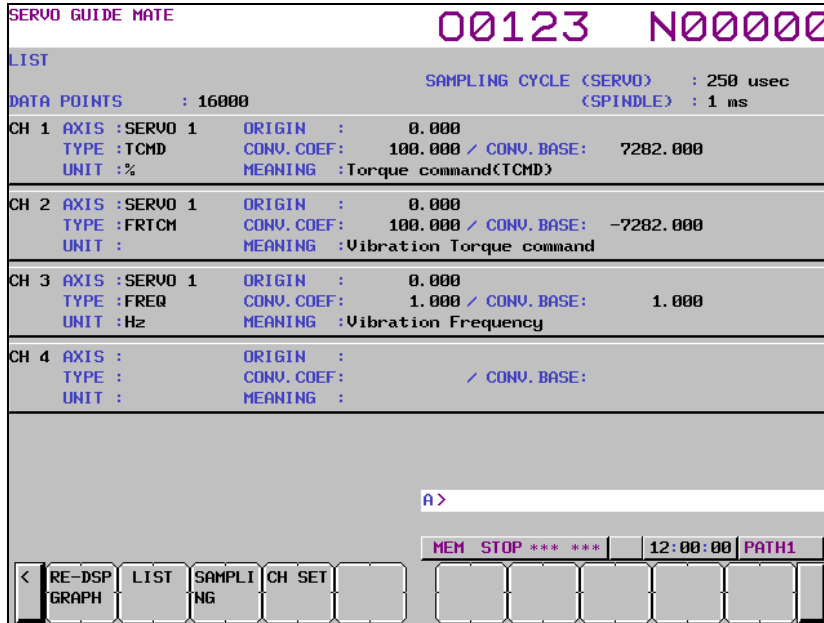

Fig. 1.9.1.1 (k)

- 3 Check the current settings on the list screen.
- 4 Click the soft key [SAMPLING].  
The data-in screen is displayed as shown Fig. 1.9.1.1 (l).

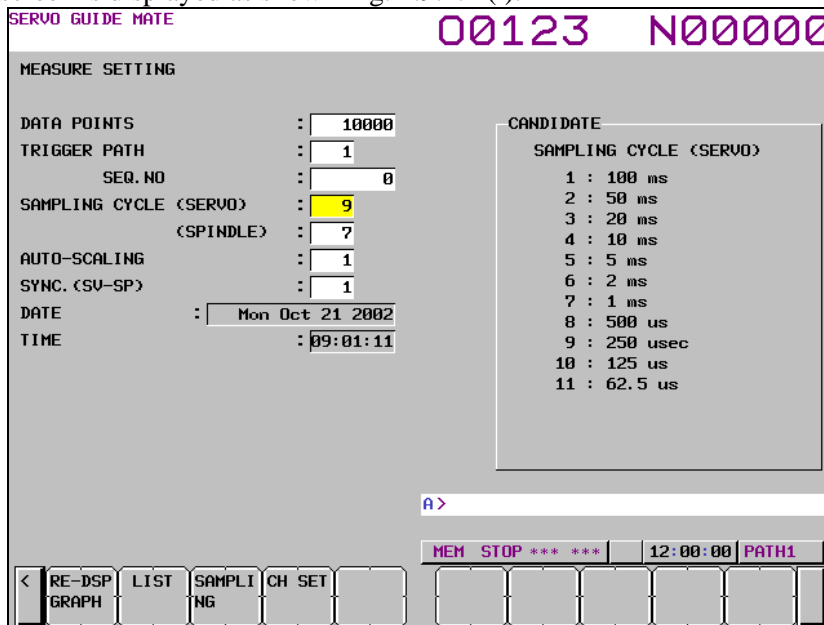





Fig. 1.9.1.1 (l)

- 5 Move the cursor to the parameter you want to set, by pressing the cursor key.
- 6 Enter data and the press the  key.
- 7 Repeat steps 5 and 6 until you set all the parameters.
- 8 Click the soft key [SET CHANNEL].  
The channel setting screen is displayed as shown Fig. 1.9.1.1 (m).  
To set any channel other than the one currently displayed, display the setting screen for the desired channel by pressing the  or  key.

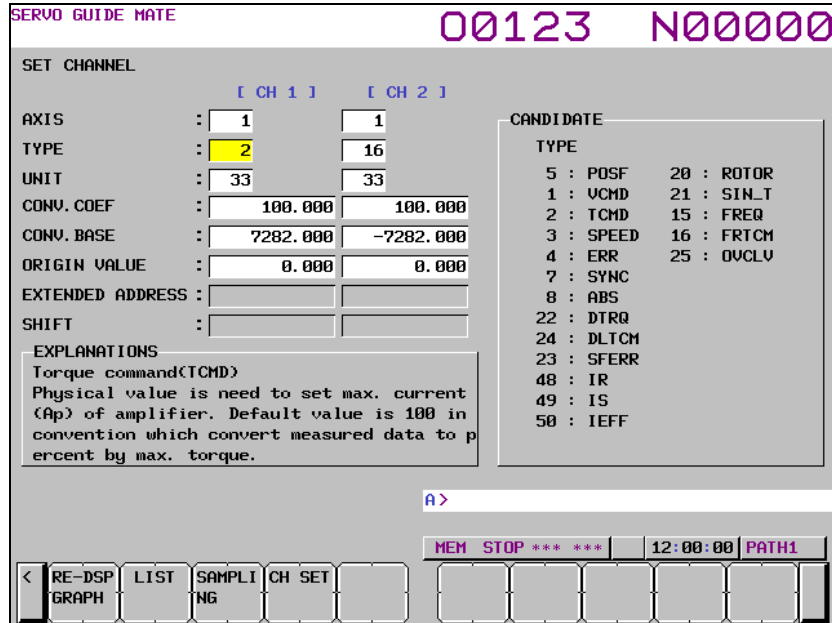



Fig. 1.9.1.1 (m)

- 9 Move the cursor to the parameter you want to set, by pressing the cursor key.
- 10 Enter data and the press the  key.
- 11 Repeat steps 9 and 10 until you set all the parameters.
- 12 Click the soft key [RE-DSPGRAPH].

The wave display screen is displayed as shown Fig. 1.9.1.1 (n).

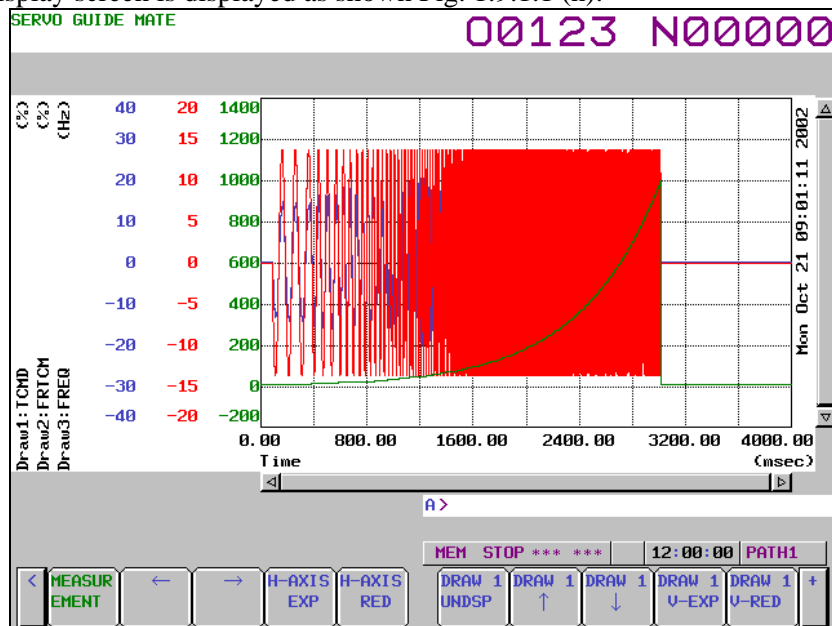

Fig. 1.9.1.1 (n)

- 13 The new settings will take effect next time you perform measurement. Change the operation/graph settings and scale settings according to the new channel settings.

## Explanation

- **Setting the data-in screen**
  - Measurement data points  
Enter a numerical value between 1 and 10000. This setting represents the number of data points to be measured.



The data measurement time is calculated by multiplying the data points by the sampling cycle. If different sampling cycles are set for the servo axis and spindle axis, the data points for the shorter sampling cycle apply. The data points for the longer sampling cycle is decreased according to the sampling cycle ratio.

- **Trigger path and sequential number**  
Enter numerical values - path number and sequential number - that specify when to trigger measurement. Numerical values that can be specified as path numbers are sequential, starting at Path 1, with the maximum value being the number of paths that are set to the CNC. The range of sequential numbers is from 0 to 99999. If 0 is specified as the sequential number, measurement starts immediately after you click the soft key [MEASUREMENT] and then the soft key [START].
- **Sampling cycle (servo and spindle)**  
Enter numerical values that specify the sampling cycles for the servo axis and spindle axis separately. The specifiable values are listed in Table 1.9.1.1 (a), Sampling cycles.

**Table 1.9.1.1 (a) Sampling cycles**

Input value	Meaning (sampling cycle)	Servo axis	Spindle axis
1	100ms	Specifiable	Specifiable
2	50ms	Specifiable	Specifiable
3	20ms	Specifiable	Specifiable
4	10ms	Specifiable	Specifiable
5	5ms	Specifiable	Specifiable
6	2ms	Specifiable	Specifiable
7	1ms	Specifiable	Specifiable
8	500 $\mu$ s	Specifiable	Specifiable
9	250 $\mu$ s	Specifiable	Unspecifiable
10	125 $\mu$ s	Specifiable	Unspecifiable
11	62.5 $\mu$ s	Specifiable	Unspecifiable

- **Auto scaling**  
Enter a numerical value that specifies whether to perform auto scaling each time a measurement is made. The specifiable values are 1 (do not perform), 2 (perform only once), and 3 (perform each time). When auto scaling is enabled, the wave scale is changed so that the entire wave can be displayed within the display range of the graph. Therefore, when you want to monitor changes in the wave size, it is better to fix the scale, rather than using the auto scaling function.
- **Synchronization mode selection**  
The specifiable values are 1 (do not select) and 2 (select).  
This function may be useful in cases where data is not synchronized in terms of time due to different sampling cycles when interpolation between servo axis and spindle axis is performed through Cs contour control or other means. (In some cases, the function may not produce any effect.)
- **Date and time**  
The date and time when data is measured are displayed. (This is a read-only item.)

#### - **Setting the channel setting screen**

Up to four sets of measurement data can be specified per channel. Be sure to set measurement data starting with the smallest channel number.

- **Axis**  
Specify an axis number for the data to be specified. Use a positive control axis number when specifying a servo axis or a negative control axis number when specifying a spindle axis. The maximum number that can be specified is equal to the number of servo axes and spindle axes that are set to the CNC respectively. When enabling channels, be sure to specify the channel numbers sequentially, starting with the smallest channel number. Setting 0 disables the channel (not measured).

- Type  
When a servo axis is selected, the specifiable values are as shown in Table 1.9.1.1 (b), Servo motor measurement data types. When a spindle axis is selected, the specifiable values are as shown in Table 1.9.1.1 (c), Spindle motor measurement data types. Specify the type of data you want to measure.

**Table 1.9.1.1 (b) Servo motor measurement data types**

Input value	Item name	Description
5	POSF	Position feedback integrated value
1	VCMD	Velocity command
2	TCMD	Torque command
3	SPEED	Motor speed
4	ERR	Position error
7	SYNC	Right tapping synchronization error (tap axis only)
8	ABS	Absolute position of the built-in pulse coder
22	DTRQ	Estimated disturbance torque
24	DLTCM	Synchronous axis torque difference
23	SFERR	Dual position feedback semi-full error
48	IR	R phase current value
49	IS	S phase current value
50	IEFF	Effective current
20	ROTOR	Rotor phase
21	SIN_T	Rotor position SINθ
15	FREQ	Disturbance input frequency (used to measure frequency characteristics)
16	FRTCM	Disturbance torque (used to measure frequency characteristics)
25	OVCLV	OVC level

**Table 1.9.1.1 (c) Spindle motor measurement data types**

Input value	Item name	Description
1	SPEED	Motor speed
2	INORM	Motor current amplitude
3	TCMD	Torque command
4	VCMD	Velocity command
5	VERR	Velocity error
7	PERR1	Position error
8	ORERR	Orientation position error
9	PCPOS	Position feedback integrated value
10	MCMD	Command pulse per ITP cycle
11	PERR2	Position error
13	CSPOS	Position feedback integrated value
14	SPCMD	Velocity command data
15	SPCT1	Spindle control signal 1
16	SPCT2	Spindle control signal 2
17	SPST1	Spindle status signal 1
18	SPST2	Spindle status signal 2
19	ORSEQ	Orientation sequence data
20	FREQ	Vibration frequency
21	FRTCM	Vibration torque command
25	PA1	AD value of the motor sensor A phase signal
26	PB1	AD value of the motor sensor B phase signal
27	PA2	AD value of the spindle sensor A phase signal
28	PB2	AD value of the spindle sensor B phase signal
29	MFDF	Motor feedback incremental data
30	SFDF	Spindle feedback incremental data
32	DTRQ	Estimated load torque

- Unit

The specifiable values are as shown in Table 1.9.1.1 (d), Measurement data units. However, as shown in Table 1.9.1.1 (e), Corresponding measurement data units, you cannot specify any unit other than that corresponding to the type of measurement data. Under normal circumstances, the automatically set values do not need to be changed. When performing polar coordinate conversion or other operation that requires information about the actual position of the rotation axis, deg needs to be selected as the unit.

Table 1.9.1.1 (d) Measurement data units

Input value	Unit	Input value	Unit
4	mm	31	A(p)
5	m	33	%
6	μm	34	pulse
7	nm	35	bit
8	inch	32	Hz
9	deg	36	--
20	1/min	38	V(p)
14	m/min	39	rev

Table 1.9.1.1 (e) Corresponding measurement data units

Servo motor data type	Corresponding unit	Spindle motor data type	Corresponding unit
5 : POSF	4 : mm 6 : μm 8 : inch 9 : deg	1 : SPEED	20 : 1/min
1 : VCMD	20 : 1/min 14 : m/min	2 : INORM	36 : -- 31 : A(p)
2 : TCMD	31 : A(p) 33 : %	3 : TCMD	33 : % 31 : A(p)
3 : SPEED	20 : 1/min 14 : m/min	4 : VCMD	20 : 1/min
4 : ERR	4 : mm 6 : μm 8 : inch 9 : deg	5 : VERR	20 : 1/min
7 : SYNC	36 : --	7 : PERR1	9 : deg
8 : ABS	4 : mm 6 : μm 8 : inch 9 : deg	8 : ORERR	9 : deg 34 : pulse
22 : DTRQ	31 : A(p)	9 : PCPOS	9 : deg
24 : DLTCM	31 : A(p)	10 : MCMD	34 : pulse
23 : SFERR	4 : mm 6 : μm 8 : inch 9 : deg	11 : PERR2	34 : pulse
48 : IR	31 : A(p) 33 : %	13 : CSPOS	9 : deg
49 : IS	31 : A(p) 33 : %	14 : SPCMD	36 : --
50 : IEFF	31 : A(p) 33 : %	15 : SPCT1	36 : --
20 : ROTOR	9 : deg	16 : SPCT2	36 : --
21 : SIN_T	36 : --	17 : SPST1	36 : --
15 : FREQ	32 : Hz	18 : SPST2	36 : --
16 : FRTCM	31 : A(p)	19 : ORSEQ	36 : --
25 : OVCLV	33 : %	20 : FREQ	32 : Hz

Servo motor data type	Corresponding unit	Spindle motor data type	Corresponding unit
		21 : FRTCM	31 : A(p)
		25:PA1	38:V(p) 33:%
		26:PB1	38:V(p) 33:%
		27:PA2	38:V(p) 33:%
		28:PB2	38:V(p) 33:%
		29:MFBDF	9:deg 39:rev
		30:SFBDF	9:deg 39:rev
		32:DTRQ	33:%

- Conversion coefficient  
Set the weight of the data selected for each channel type (numerator = physical amount). For POSF and other position-related data, specify the amount of travel per pulse. For VCMD and SPEED, specify 3750. For TCMD, specify the maximum current value of the amplifier in use.
- Conversion base  
Set the weight of the data selected for each channel type (denominator = raw data unit). Under normal circumstances, use the value that is automatically set when the type is selected. Usually, the system automatically sets 1 for POSF and other position-related data, 32768 for VCMD and SPEED, and 7282 for TCMD.
- Origin value  
Specify the value that is to be set as the initial value for each channel when you click the soft key [MEASUREMENT] and then the soft key [ORIGIN].
- Extended address  
Under normal circumstances, this item is unspecifiable and not used. (This is a read-only item.)
- Shift  
Under normal circumstances, this item is unspecifiable and not used. (A value may be set automatically when the type is selected.)

**- Setting the operation and graph setting screen**

In the operation and graph setting screen, up to four graphs can be set per draw.

- Operation  
The specifiable values are as shown in Table 1.9.1.1 (f), Y-time graph operations.  
An operation cannot be specified if it does not meet the graph display conditions defined in Table 1.9.1.1 (g), Y-time graph conditions.

**Table 1.9.1.1 (f) Y-time graph operations**

Input value	Operation name	Description
1	N/A	Not displayed.
2	Y-Time	Normal display (The data of the selected channel is displayed as is, without performing any operations.) Input 1 is the vertical axis. All measurement channels are available to be selected.
3	Diff1 ( VT )	First order differential display of position data (equivalent to velocity) Input 1 is the vertical axis. Only those channels whose positions have been measured can be selected.
4	Diff2 ( AT )	Second order differential display of position data (equivalent to acceleration) Input 1 is the vertical axis. Only those channels whose positions have been measured can be selected.

Input value	Operation name	Description
5	Tangent	Tangent speed display Only those channels whose positions have been measured can be selected. The combined speed of input 1 and input 2 is displayed.
6	Tangent N	N axis tangent speed display Only those channels whose positions have been measured can be selected. The combined speed for the position data from the channel specified by input 1 to the channel specified by input 2 is displayed. All channels to be combined need to have position data.
7	Smooth	Feed smoothness display Only those channels whose positions have been measured can be selected. This item displays the deviation from the ideal position calculated on the assumption that the tool moves from the displayed start time (start point) to the end time (end point) at a constant speed.
8	Synchro	Synchronization error display Only those channels whose positions have been measured can be selected. This item displays the difference between input 1 and input 2. Currently, only 1-to-1 ratio is supported as the proportion of input 1 to input 2.
9	Bit	Bit display The status of the corresponding bit specified by input 2 is displayed, based on the measurement data for the channel specified by input 1.

Table 1.9.1.1 (g) Y-time graph conditions

Operation	Coordinate conversion	Input 1	Input 2	Remarks
2 : Y-Time	1 : Normal	Channel whose position has been measured	Not specified	
	2 : Polar	Channel whose position has been measured (only when the data unit is mm, $\mu$ m, or inch)	Channel whose position has been measured (only when the data unit is deg)	
	3 : Angular	Channel whose position has been measured	Channel whose position has been measured	
3 : Diff1 ( VT )	1 : Normal	Channel whose position has been measured	Not specified	
4 : Diff2 ( AT )	1 : Normal	Channel whose position has been measured	Not specified	
5 : Tangent	1 : Normal	Channel whose position has been measured	Channel whose position has been measured	
	2 : Polar	Channel whose position has been measured (only when the data unit is mm, $\mu$ m, or inch)	Channel whose position has been measured (only when the data unit is deg)	
	3 : Angular	Channel whose position has been measured	Channel whose position has been measured	
6 : Tangent N	1 : Normal	Channel whose position has been measured	Channel whose position has been measured	Make sure that the measured data unit is either mm, $\mu$ m, or inch, or deg.
7 : Smooth	1 : Normal	Channel whose position has been measured	Not specified	
8 : Synchro	1 : Normal	Channel whose position has been measured	Channel whose position has been measured	
9 : Bit	1 : Normal	Channel whose position has been measured	Bit position	

- **Input 1**  
Specifiable values are sequential, with channel 1 being 1. The maximum value is the largest channel number for which measurement is set during the channel setting process. A value that does not meet the graph display conditions defined in Table 1.9.1.1 (g), Y-time graph conditions cannot be specified in input 1.
- **Input 2**  
Specifiable values are sequential, with channel 1 being 1. The maximum value is the largest channel number for which measurement is set during the channel setting process. Note that, when Bit is specified as the operation, values are sequentially set, with bit position 0 being 10. In this case, the maximum value is 25, which indicates bit position 15. A value that does not meet the graph display conditions defined in Table 1.9.1.1 (g), Y-time graph conditions cannot be specified in input 2.
- **Display unit**  
Specifiable values are as shown in Table 1.9.1.1 (h), Display units. The conditions for specifying these display units are as shown in Table 1.9.1.1 (i), Y-time graph display units.

**Table 1.9.1.1 (h) Display units**

<b>Input value</b>	<b>Unit</b>	<b>Input value</b>	<b>Unit</b>
1	sec	19	1/sec
2	msec	20	1/min
3	μsec	21	mm/sec/sec
4	mm	22	mm/min/min
5	m	23	m/sec/sec
6	μm	24	m/min/min
7	nm	25	inch/sec/sec
8	inch	26	inch/min/min
9	deg	27	deg/sec/sec
10	mdeg	28	deg/min/min
11	mm/sec	29	1/sec/sec
12	mm/min	30	1/min/min
13	m/sec	31	A(p)
14	m/min	32	Hz
15	inch/sec	33	%
16	inch/min	34	pulse
17	deg/sec	35	bit
18	deg/min	36	--

Table 1.9.1.1 (i) Corresponding Y-time graph display units

Operation	Input 1 measurement data unit	Specifiable display unit	
2 : Y-Time	4 : mm	4 : mm	
	5 : m	5 : m	
	6 : $\mu\text{m}$	6 : $\mu\text{m}$	
	7 : nm	7 : nm	
	8 : inch	8 : inch	
	9 : deg	9 : deg	
	14 : m/min		11 : mm/sec
			12 : mm/min
			13 : m/sec
			14 : m/min
20 : 1/min		15 : inch/sec	
		16 : inch/min	
		17 : deg/sec	
		18 : deg/min	
	19 : 1/sec		
	20 : 1/min		
31 : A(p)	31 : A(p)		
32 : Hz	32 : Hz		
33 : %	33 : %		
34 : pulse	34 : pulse		
35 : bit	35 : bit		
36 : --	36 : --		
3 : Diff1 ( VT )	4 : mm	11 : mm/sec	
	5 : m	12 : mm/min	
	6 : $\mu\text{m}$	13 : m/sec	
	7 : nm	14 : m/min	
	8 : inch	15 : inch/sec	
		16 : inch/min	
	9 : deg	17 : deg/sec	
		18 : deg/min	
		19 : 1/sec	
		20 : 1/min	
4 : Diff2 ( AT )	4 : mm	21 : mm/sec/sec	
	5 : m	22 : mm/min/min	
	6 : $\mu\text{m}$	23 : m/sec/sec	
	7 : nm	24 : m/min/min	
	8 : inch	25 : inch/sec/sec	
		26 : inch/min/min	
	9 : deg	27 : deg/sec/sec	
		28 : deg/min/min	
		29 : 1/sec/sec	
		30 : 1/min/min	
5 : Tangent	4 : mm	11 : mm/sec	
	5 : m	12 : mm/min	
	6 : $\mu\text{m}$	13 : m/sec	
	7 : nm	14 : m/min	
	8 : inch	15 : inch/sec	
	9 : deg	16 : inch/min	
6 : Tangent N	4 : mm	11 : mm/sec	
	5 : m	12 : mm/min	
	6 : $\mu\text{m}$	13 : m/sec	
	7 : nm	14 : m/min	
	8 : inch	15 : inch/sec	
	9 : deg	16 : inch/min	

Operation	Input 1 measurement data unit	Specifiable display unit
7 : Smooth	4 : mm 5 : m 6 : μm 7 : nm 8 : inch 9 : deg	4 : mm 5 : m 6 : μm 7 : nm 8 : inch 9 : deg
8 : Synchro	Not affected by the measurement unit.	4 : mm 5 : m 6 : μm 7 : nm 8 : inch 9 : deg 36 : --
9 : Bit	Not affected by the measurement unit.	Not specified.

- Coordinate conversion  
Specifiable values are 1 (Normal; no coordinate conversion), 2 (Polar; coordinate conversion for polar coordinate interpolation), and 3 (Angular; coordinate conversion for angular axis control). The conditions for the specifiable coordinate conversion types are as shown in Table 1.9.1.1 (j), Corresponding Y-time graph coordinate conversion types. Note that no conditions are imposed for specifying Normal (no coordinate conversion).

**Table 1.9.1.1 (j) Corresponding Y-time graph coordinate conversion types**

Operation	Input 1	Input 2	Specifiable coordinate conversion
2 : Y-Time 5 : Tangent	Channel whose position has been measured (only when the data unit is mm, μm, or inch)	Channel whose position has been measured (only when the data unit is deg)	2 : Polar
	Channel whose position has been measured	Channel whose position has been measured	3 : Angular

- Inclination  
Specify the inclination in degrees. The specified value is effective only when Angular (coordinate conversion for angular axis control) is specified as the coordinate conversion type.

**- Setting the scale screen**

The scale screen lets you set up to four scales per draw and specify the graph scale with respect to the time axis.

- Start point  
Set the center coordinate of the displayed data (Draw 1 to Draw 4; vertical axis).  
Set the display start time for time (horizontal axis).
- Division  
Set the value of the displayed data per grid (Draw 1 to Draw 4; vertical axis).  
Set the amount of time per grid for time (horizontal axis).

**- Operation for measurement**

- Origin  
Arrange that the origin value, set on a per-channel basis in the channel setting screen, will be the initial value for the measurement data when measurement is started. This operation is effective only for those channels for which position measurement is set.



## Limitation

### - Data update cycle

Position-related data is updated at intervals of 1 ms, and power-related data is updated at the current cycle. Therefore, even if you specify a sampling cycle that is shorter than the data update cycle, the displayed data remains unchanged during the present data update cycle.

### - Sampling cycle and the number of channels measured

Regarding the sampling cycle and the number of channels measured, there are limitations as shown in Table 1.9.1.1 (k).

Table 1.9.1.1 (k) Sampling cycle and the number of channels measured

Sampling cycle	Maximum number of channels measured
1ms or more	4
500 $\mu$ s	4
250 $\mu$ s	4
125 $\mu$ s	4
62.5 $\mu$ s	2 (Channel 3 or later cannot be input.)

The following limitations are imposed on the servo axis and spindle axis.

Number of channels that can be acquired per servo DSP

- Up to four channels can be acquired when the sampling cycle is 1 ms or longer, 500  $\mu$ s, or 250  $\mu$ s.
- Up to two channels can be acquired when the sampling cycle is 125  $\mu$ s.
- Only one channel can be acquired when the sampling cycle is 62.25  $\mu$ s.

Number of channels that can be acquired per spindle axis

- Up to two channels can be acquired when the sampling cycle is 1 ms or longer.
- Only one channel can be acquired when the sampling cycle is 500 ms.

## 1.9.1.2 XY graph



This graph provides a 2-dimensional path display of measurement data by using 2-axis data.

Up to two draws can be displayed at a time.

## Displaying and setting the XY graph

### Procedure

The procedure for displaying the measurement data is described below.

- 1 Press the  function key.
- 2 Press the continuous menu key  several times until [SERVO GUIDE MATE] is displayed.
- 3 Click the soft key [SERVO GUIDE MATE].
- 4 Click the soft key [XY].

The wave display screen is displayed as shown Fig. 1.9.1.2 (a).

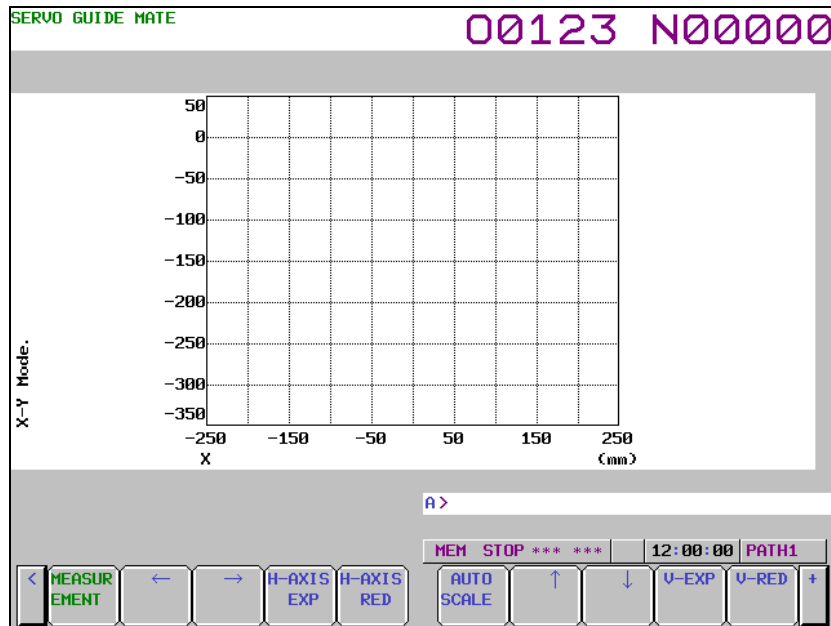

Fig. 1.9.1.2 (a)

- 5 Click the soft key [MEASUREMENT].
- 6 Click the soft key [DATA IN].
- 7 Click the soft key [SAMPLING].

The data-in screen is displayed as shown Fig. 1.9.1.2 (b).

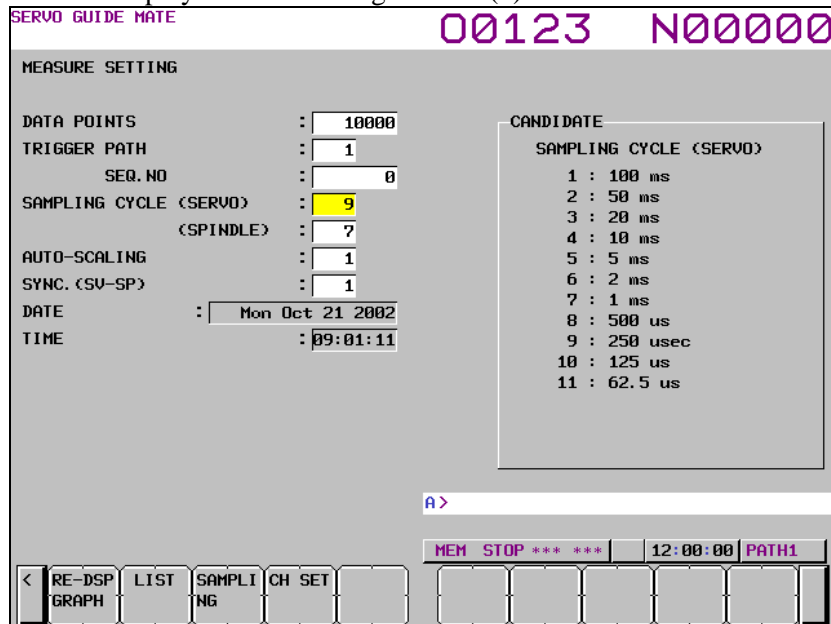





Fig. 1.9.1.2 (b)

- 8 Move the cursor to the parameter you want to set, by pressing the cursor key.
- 9 Enter data and the press the  key.
- 10 Repeat steps 8 and 9 until you set all the parameters.
- 11 Click the soft key [SET CHANNEL].

The channel setting screen is displayed as shown Fig. 1.9.1.2 (c).

To set any channel other than the one currently displayed, display the setting screen for the desired channel by pressing the  or  key.

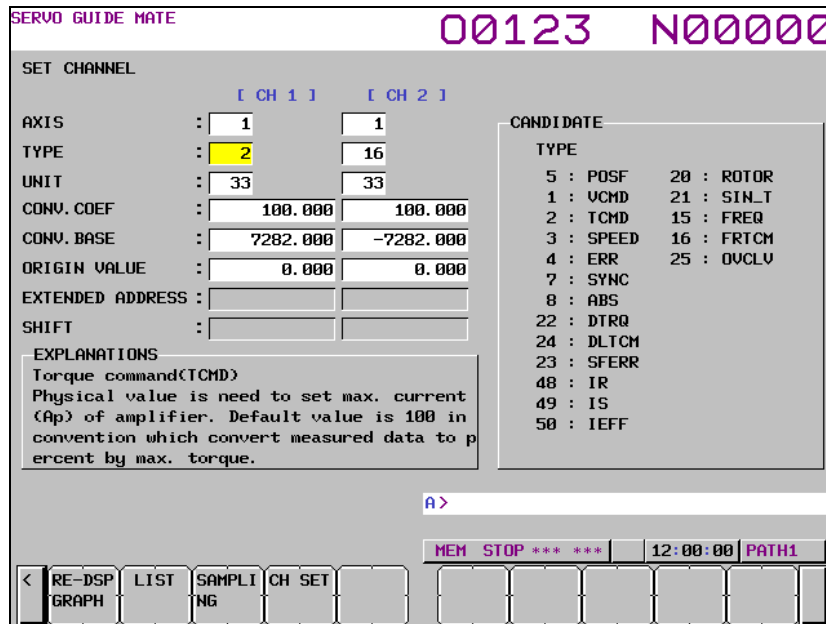



Fig. 1.9.1.2 (c)

12 Move the cursor to the parameter you want to set, by pressing the cursor key.



13 Enter data and the press the  key.

14 Repeat steps 12 and 13 until you set all the parameters.

15 Click the soft key [RE-DSPGRAPH].

16 Click the soft key [OPERATION & GRAPH].

The operation and graph setting screen is displayed as shown Fig. 1.9.1.2 (d).

To set any draw other than the one currently displayed, display the setting screen for the desired draw by pressing the  or  key.

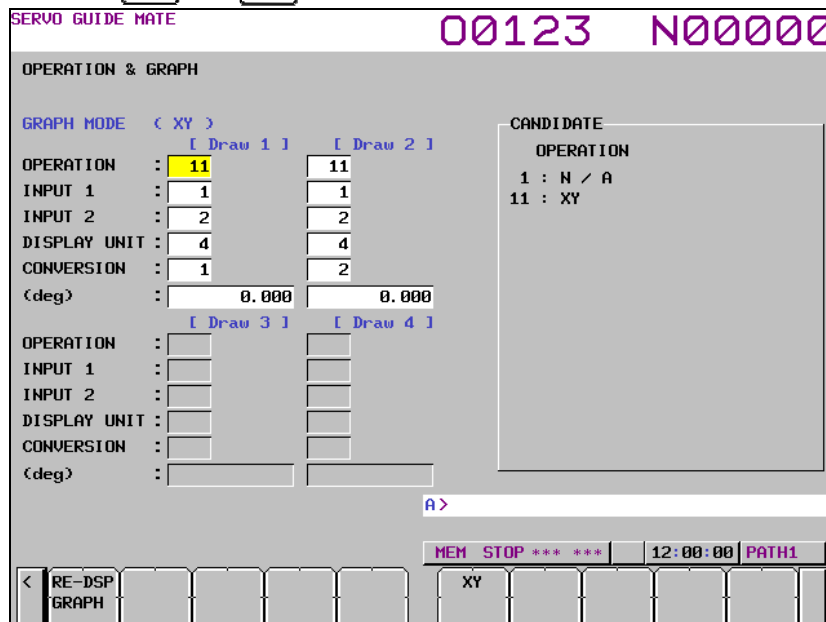



Fig. 1.9.1.2 (d)

17 Move the cursor to the parameter you want to set, by pressing the cursor key.

18 Enter data and the press the  key.

19 Repeat steps 17 and 18 until you set all the parameters.

20 Click the soft key [RE-DSPGRAPH].

- 21 Click the soft key [SCALE SET].  
The scale setting screen is displayed as shown Fig. 1.9.1.2 (e).

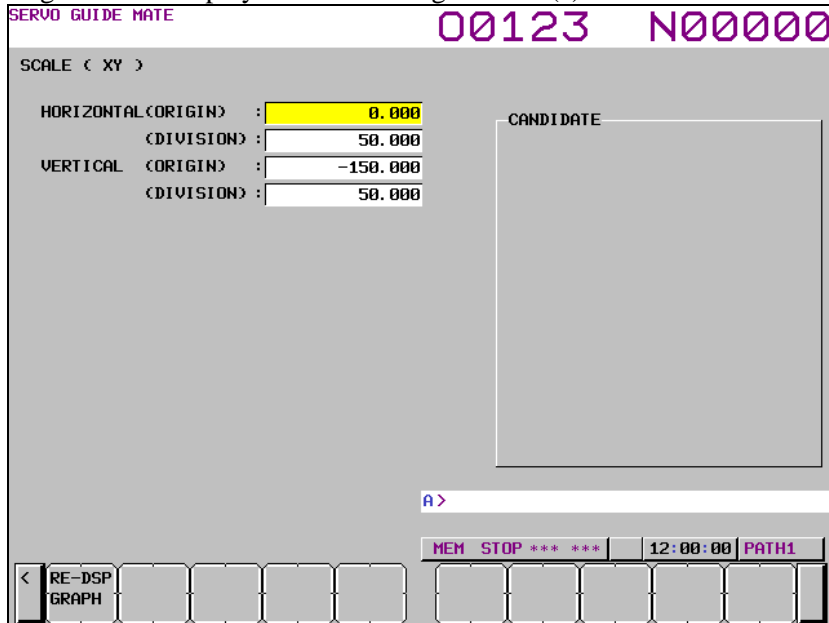



Fig. 1.9.1.2 (e)

- 22 Move the cursor to the parameter you want to set, by pressing the cursor key.
- 23 Enter data and the press the  key.
- 24 Repeat steps 22 and 23 until you set all the parameters.
- 25 Click the soft key [RE-DSPGRAPH].
- 26 Click the soft key [MEASUREMENT].
- 27 Click the soft key [START].
- 28 Start the automatic or manual operation.
- 29 When the measurement is completed, the wave display screen is displayed as shown Fig. 1.9.1.2 (f).

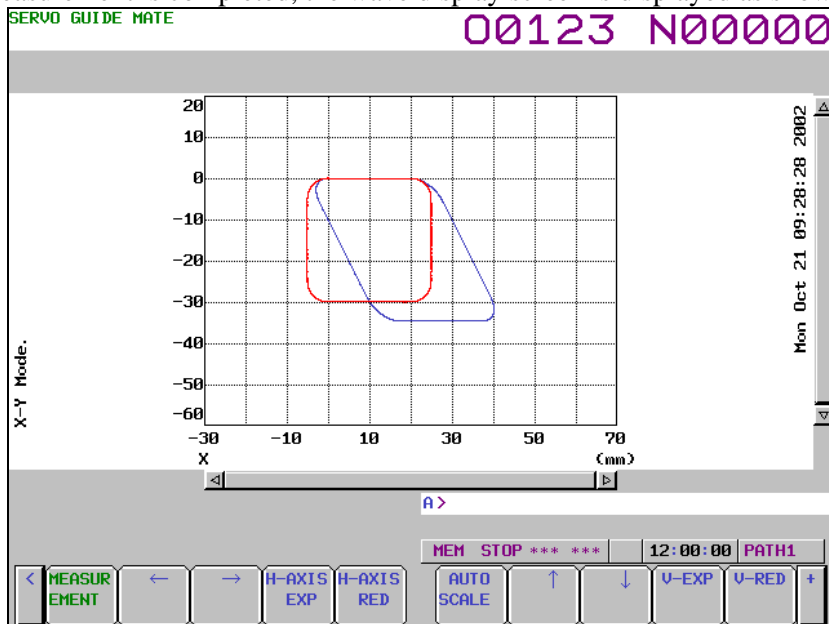



Fig. 1.9.1.2 (f)

**- Changing the operation and graph setting screen**

The procedure for changing the operation and graph setting screen as necessary is described below.

- 1 Click the soft key [OPERATION & GRAPH].  
 The operation and graph setting screen is displayed as shown Fig. 1.9.1.2 (g).  
 To set any draw other than the one currently displayed, display the setting screen for the desired draw by pressing the  or  key.

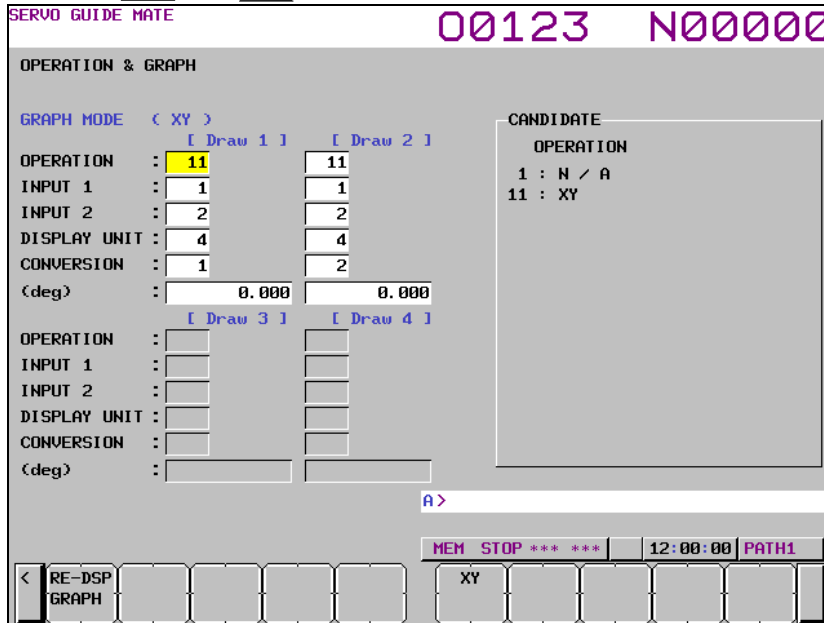



Fig. 1.9.1.2 (g)

- 2 Move the cursor to the parameter you want to set, by pressing the cursor key.
- 3 Enter data and the press the  key.
- 4 Repeat steps 2 and 3 until you set all the parameters.
- 5 Click the soft key [RE-DSPGRAPH].  
 Based on the new operation and graph settings, the wave display screen is displayed as shown Fig. 1.9.1.2 (h).

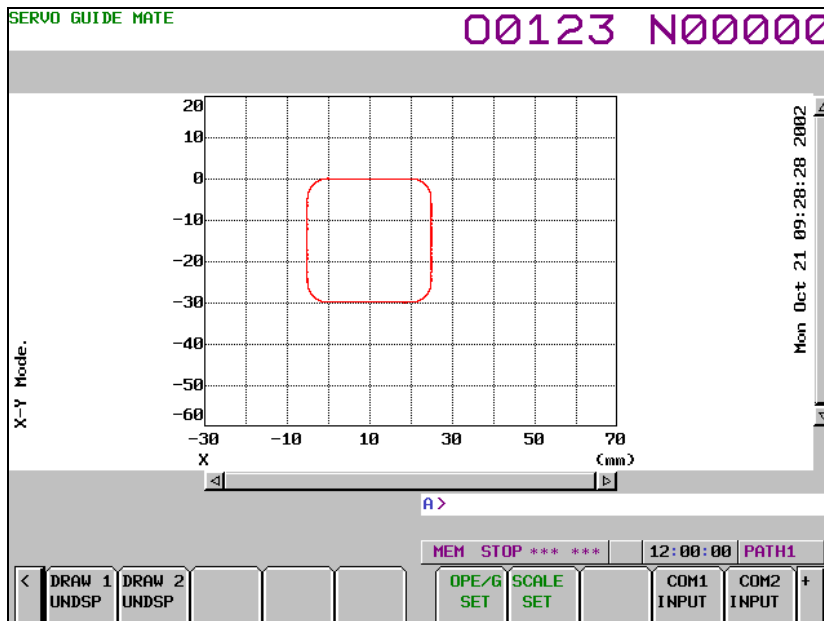

Fig. 1.9.1.2 (h)

**- Changing the scale screen**

The procedure for changing the scale settings as necessary is described below.

- 1 Click the soft key [SCALE SET].  
The scale setting screen is displayed as shown Fig. 1.9.1.2 (i).

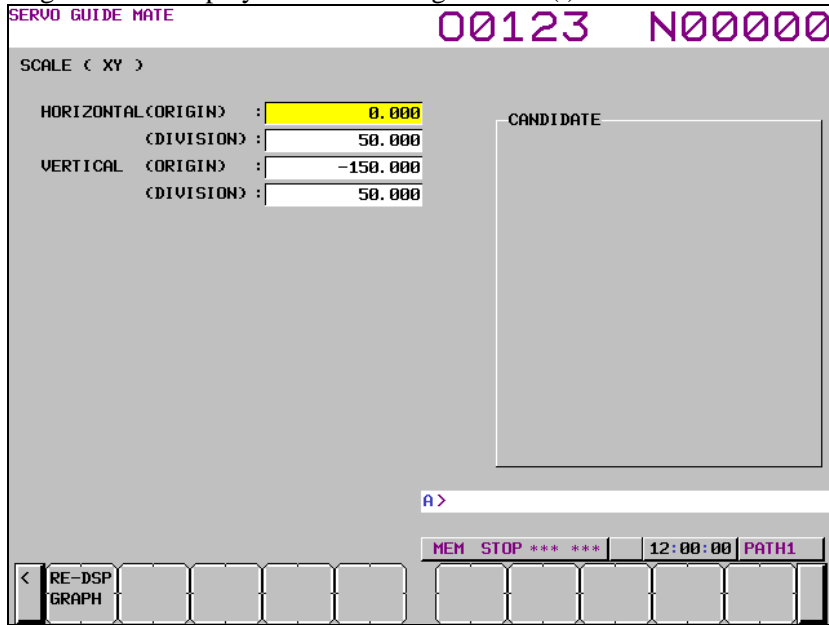



Fig. 1.9.1.2 (i)

- 2 Move the cursor to the parameter you want to set, by pressing the cursor key.
- 3 Enter data and the press the  key.
- 4 Repeat steps 2 and 3 until you set all the parameters.
- 5 Click the soft key [RE-DSPGRAPH].  
Based on the new scale settings, the wave display screen is displayed as shown Fig. 1.9.1.2 (j).

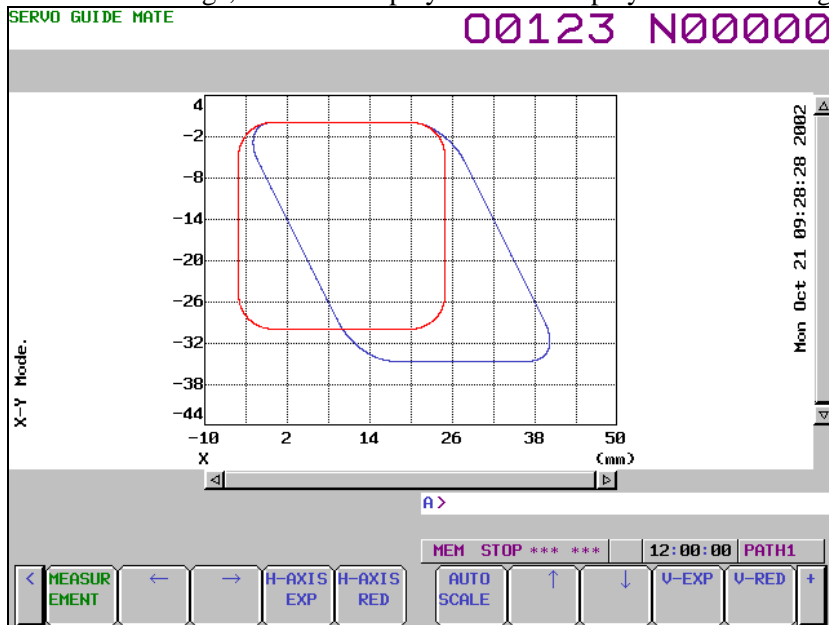

Fig. 1.9.1.2 (j)

**- Manipulating the XY graph**

By clicking the following soft keys, you can perform the operations corresponding to them.

- [MEASUREMENT] : Performs a measurement-related operation.
- [←] : Shifts the horizontal axis to the right.
- [→] : Shifts the horizontal axis to the left.
- [H-AXIS EXP] : Expands the horizontal axis.

- [H-AXIS RED] : Reduces the horizontal axis.
- [AUTO SCALE] : Enables auto scaling.
- [↑] : Shifts the vertical axis downward.
- [↓] : Shifts the vertical axis upward.
- [V-AXIS EXP] : Expands the vertical axis.
- [V-AXIS RED] : Reduces the vertical axis.
- [DRAW 1UNDSP] : Sets whether or not to display Draw 1.
- [DRAW 2UNDSP] : Sets whether or not to display Draw 2.
- [OPE/G SET] : Sets operations and graphs.
- [SCALE SET] : Sets scales.
- [COM1 INPUT] : Inputs comment 1.
- [COM2 INPUT] : Inputs comment 2.
- [Y-TIME] : Switches to the Y-Time graph.
- [CIRCLE] : Switches to the Circle graph.
- [FOURIER] : Switches to the Fourier graph.
- [BODE] : Switches to the Bode graph.

**- Performing measurement**



When you click the soft key [MEASUREMENT], you can perform the operations corresponding to the menu items that follow.

- [START] : Starts measurement.
- [ORIGIN] : Sets the origin value.
- [STOP] : Stops measurement.
- [DATA IN] : Specifies measurement-related settings.

**- Changing measurement settings**

- 1 When you click the soft key [MEASUREMENT] and then the soft key [DATA IN], you can perform the operations corresponding to the menu items that follow.
- 2 Click the soft key [LIST].

The list screen is displayed as shown Fig. 1.9.1.2 (k).

To display any channel other than the one currently displayed, display the list screen for the desired channel by pressing the  or  key.

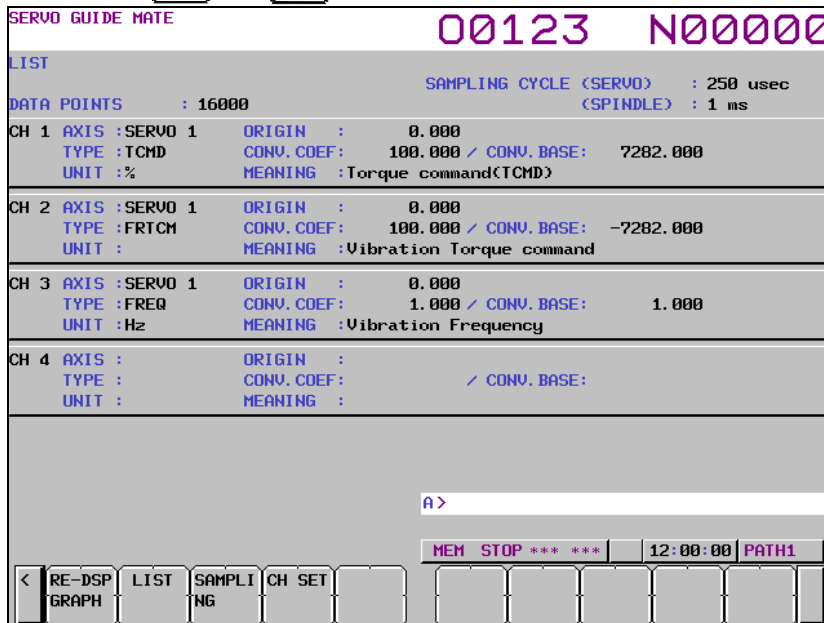

Fig. 1.9.1.2 (k)

- 3 Check the current settings on the list screen.

- 4 Click the soft key [SAMPLING].  
The data-in screen is displayed as shown Fig. 1.9.1.2 (l).

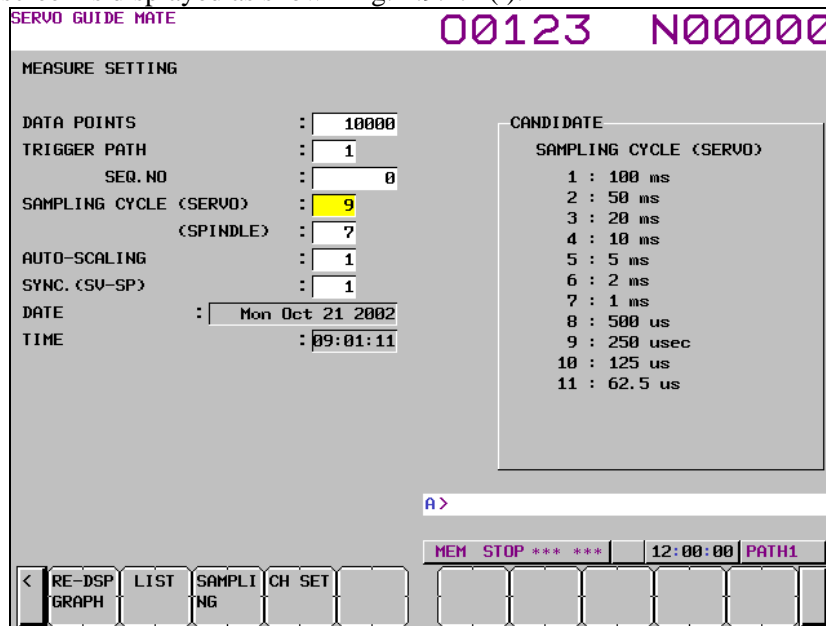





Fig. 1.9.1.2 (l)

- 5 Move the cursor to the parameter you want to set, by pressing the cursor key.
- 6 Enter data and the press the  key.
- 7 Repeat steps 5 and 6 until you set all the parameters.
- 8 Click the soft key [SET CHANNEL].  
The channel setting screen is displayed as shown Fig. 1.9.1.2 (m).  
To set any channel other than the one currently displayed, display the setting screen for the desired channel by pressing the  or  key.

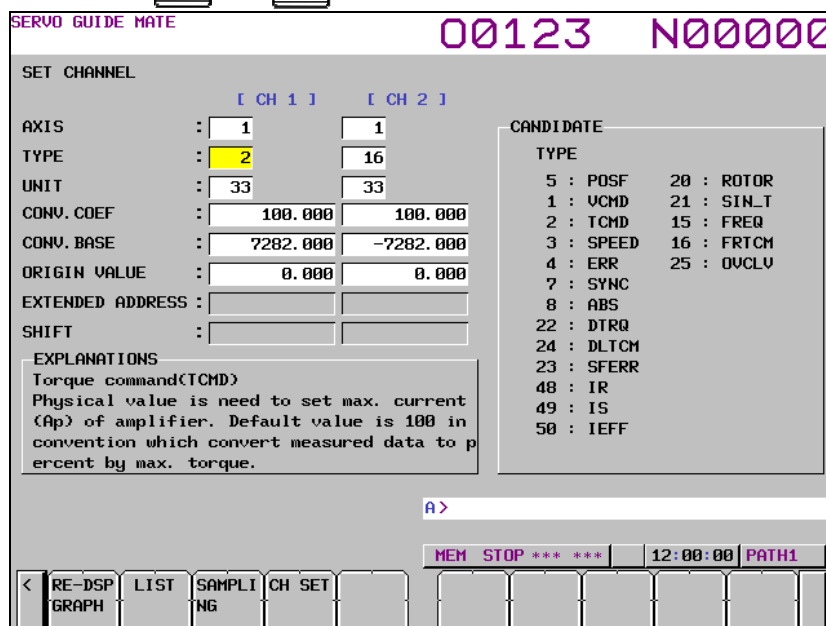



Fig. 1.9.1.2 (m)

- 9 Move the cursor to the parameter you want to set, by pressing the cursor key.
- 10 Enter data and the press the  key.
- 11 Repeat steps 9 and 10 until you set all the parameters.



- 12 Click the soft key [RE-DSPGRAPH].  
The wave display screen is displayed as shown Fig. 1.9.1.2 (n).

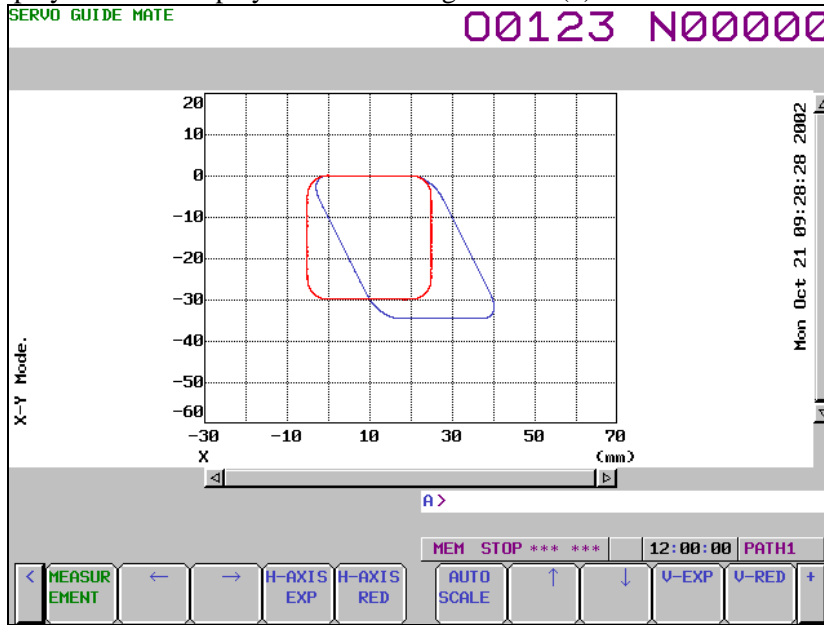

Fig. 1.9.1.2 (n)

- 13 The new settings will take effect next time you perform measurement. Change the operation/graph settings and scale settings according to the new channel settings.

**Explanation**

**- Setting the data-in screen**

See the Explanation section for the Y-time graph describing the setting of the data-in screen.

**- Setting the channel setting screen**

See the Explanation section for the Y-time describing the setting of the channel setting screen.

**- Setting the operation and graph setting screen**

In the operation and graph setting screen, up to two graphs can be set per draw.

• Operation

The specifiable values are as shown in Table 1.9.1.2 (a), XY graph operations.

An operation cannot be specified if it does not meet the graph display conditions defined in Table 1.9.1.2 (b), XY graph conditions.

Table 1.9.1.2 (a) XY graph operations

Input value	Operation name	Description
1	N/A	Not displayed.
11	XY	XY display Input 1 is the horizontal axis. Input 2 is the vertical axis.

**Table 1.9.1.2 (b) XY graph conditions**

Operation	Coordinate conversion	Input 1	Input 2	Remarks
11 : XY	1 : Normal	Channel whose position has been measured	Channel whose position has been measured	
	2 : Polar	Channel whose position has been measured (only when the data unit is mm, $\mu\text{m}$ , or inch)	Channel whose position has been measured (only when the data unit is deg)	
	3 : Angular	Channel whose position has been measured	Channel whose position has been measured	

- **Input 1**  
Specifiable values are sequential, with channel 1 being 1. The maximum value is the largest channel number for which measurement is set during the channel setting process. A value that does not meet the graph display conditions defined in Table 1.9.1.2 (b), XY graph conditions cannot be specified in input 1.
- **Input 2**  
Specifiable values are sequential, with channel 1 being 1. The maximum value is the largest channel number for which measurement is set during the channel setting process. A value that does not meet the graph display conditions defined in Table 1.9.1.2 (b), XY graph conditions cannot be specified in input 2.
- **Display unit**  
The specifiable value is 4 (mm) only.
- **Coordinate conversion**  
Specifiable values are 1 (Normal; no coordinate conversion), 2 (Polar; coordinate conversion for polar coordinate interpolation), and 3 (Angular; coordinate conversion for angular axis control). The conditions for the specifiable coordinate conversion types are as shown in Table 1.9.1.2 (c), Corresponding XY graph coordinate conversion types.

**Table 1.9.1.2 (c) Corresponding XY graph coordinate conversion types**

Operation	Input 1	Input 2	Specifiable coordinate conversion
11 : XY	Channel whose position has been measured	Channel whose position has been measured	1 : Normal
	Channel whose position has been measured (only when the data unit is mm, $\mu\text{m}$ , or inch)	Channel whose position has been measured (only when the data unit is deg)	2 : Polar
	Channel whose position has been measured	Channel whose position has been measured	3 : Angular

- **Inclination**  
Specify the inclination in degrees. The specified value is effective only when Angular (coordinate conversion for angular axis control) is specified as the coordinate conversion type.
- **Setting the scale screen**
- **Start point**  
Set the center coordinates of the horizontal axis and vertical axis of the displayed data, respectively.
  - **Division**  
Set the value of one grid of the horizontal axis and vertical axis of the displayed data, respectively.
- **Operation for measurement**  
See the Explanation section for the Y-time graph describing the operation for measurement.

## Limitation

See the Limitation section for the Y-time graph.

### 1.9.1.3 Circle graph



This graph displays an enlarged view of the path deviation from the specified circle arising during circular cutting.

Only one draw can be displayed.

## Displaying and setting the circle graph

### Procedure

The procedure for displaying the measurement data is described below.

- 1 Press the  function key.
- 2 Press the continuous menu key  several times until [SERVO GUIDE MATE] is displayed.
- 3 Click the soft key [SERVO GUIDE MATE].
- 4 Click the soft key [CIRCLE].

The wave display screen is displayed as shown Fig. 1.9.1.3 (a).

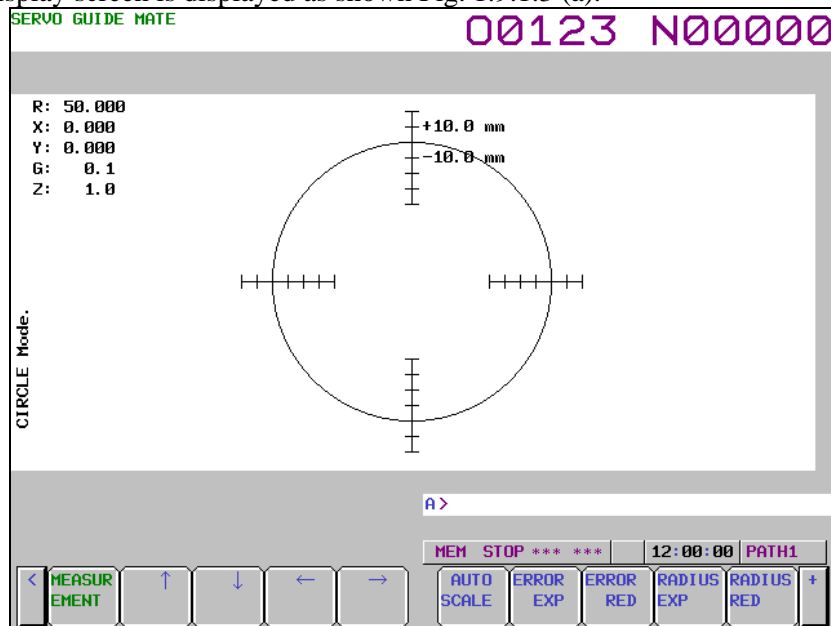

Fig. 1.9.1.3 (a)

- 5 Click the soft key [MEASUREMENT].
- 6 Click the soft key [DATA IN].

- 7 Click the soft key [SAMPLING].  
The data-in screen is displayed as shown Fig. 1.9.1.3 (b).

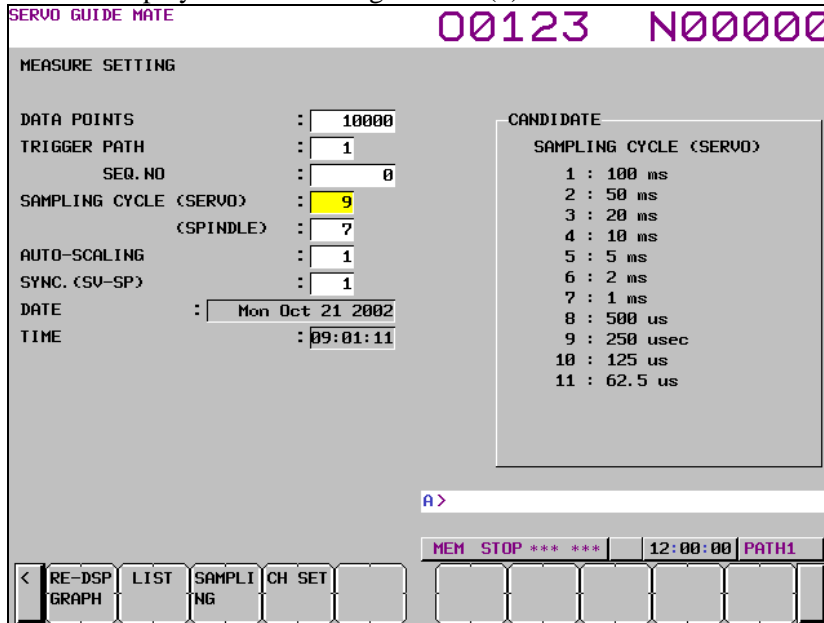





Fig. 1.9.1.3 (b)

- 8 Move the cursor to the parameter you want to set, by pressing the cursor key.
- 9 Enter data and the press the  key.
- 10 Repeat steps 8 and 9 until you set all the parameters.
- 11 Click the soft key [SET CHANNEL].  
The channel setting screen is displayed as shown Fig. 1.9.1.3 (c).  
To set any channel other than the one currently displayed, display the setting screen for the desired channel by pressing the  or  key.

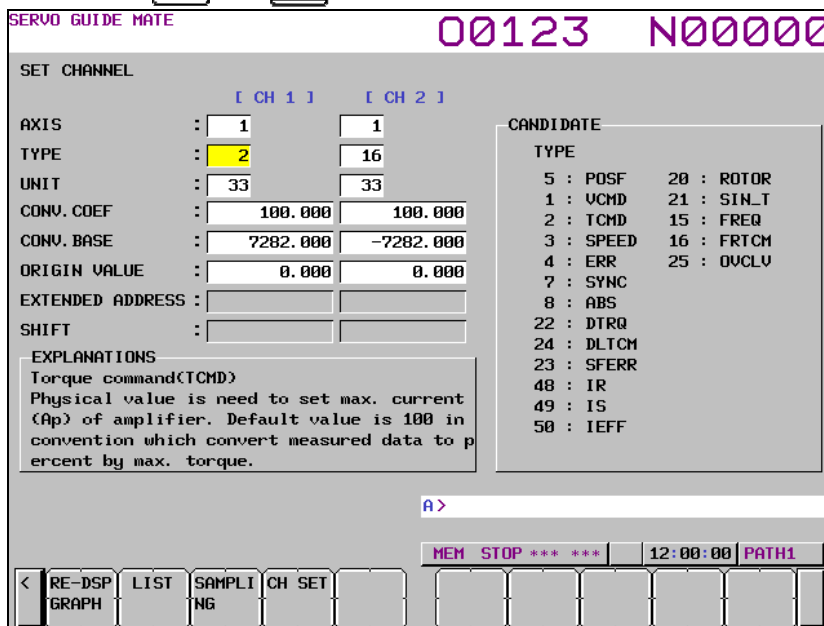



Fig. 1.9.1.3 (c)

- 12 Move the cursor to the parameter you want to set, by pressing the cursor key.
- 13 Enter data and the press the  key.
- 14 Repeat steps 12 and 13 until you set all the parameters.

- 15 Click the soft key [RE-DSPGRAPH].
  - 16 Click the soft key [OPERATION & GRAPH].
- The operation and graph setting screen is displayed as shown Fig. 1.9.1.3 (d).

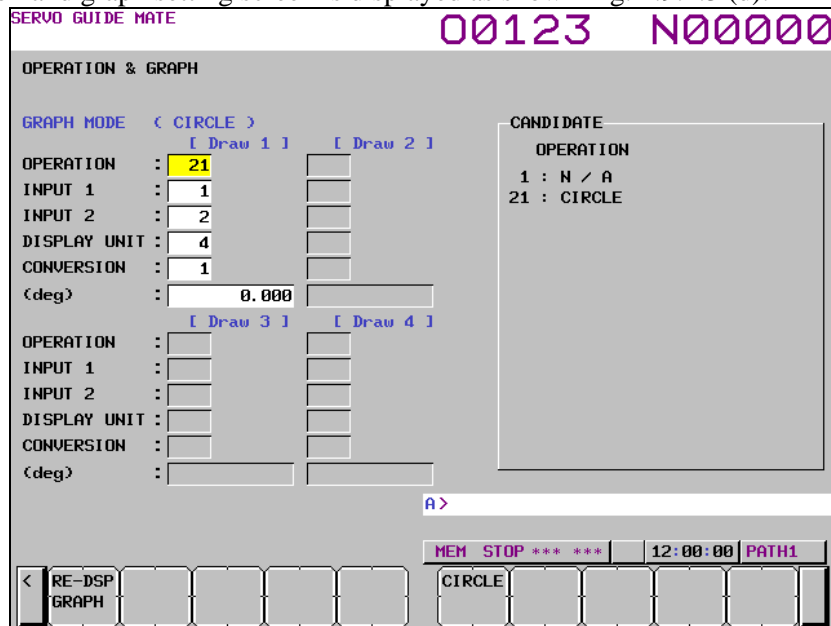



Fig. 1.9.1.3 (d)

- 17 Move the cursor to the parameter you want to set, by pressing the cursor key.
- 18 Enter data and the press the  key.
- 19 Repeat steps 17 and 18 until you set all the parameters.
- 20 Click the soft key [RE-DSPGRAPH].
- 21 Click the soft key [SCALE SET].

The scale setting screen is displayed as shown Fig. 1.9.1.3 (e).

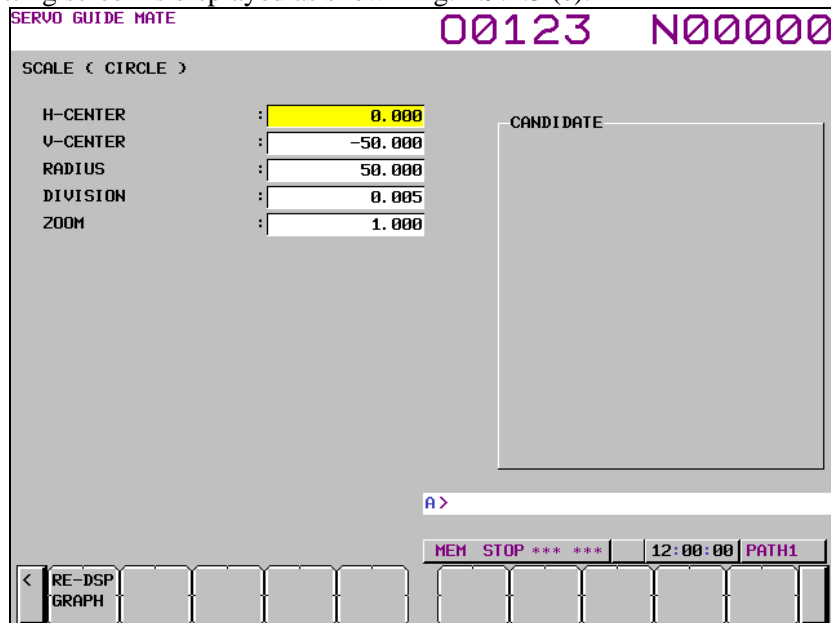



Fig. 1.9.1.3 (e)

- 22 Move the cursor to the parameter you want to set, by pressing the cursor key.
- 23 Enter data and the press the  key.
- 24 Repeat steps 22 and 23 until you set all the parameters.

- 25 Click the soft key [RE-DSPGRAPH].
- 26 Click the soft key [MEASUREMENT].
- 27 Click the soft key [START].
- 28 Start the automatic or manual operation.
- 29 When the measurement is completed, the wave display screen is displayed as shown Fig. 1.9.1.3 (f).

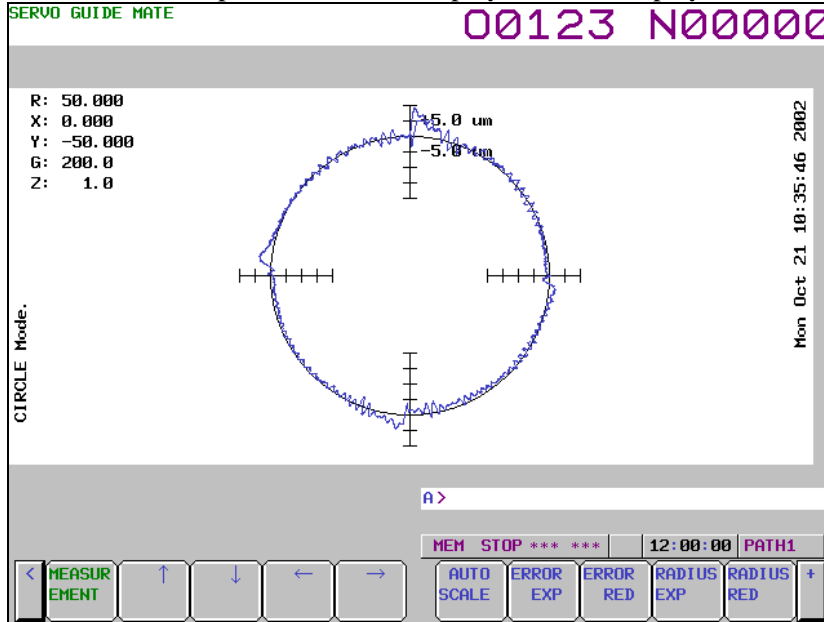

Fig. 1.9.1.3 (f)

**- Changing the operation and graph setting screen**

The procedure for changing the operation and graph setting screen as necessary is described below.

- 1 Click the soft key [OPERATION & GRAPH].

The operation and graph setting screen is displayed as shown Fig. 1.9.1.3 (g).

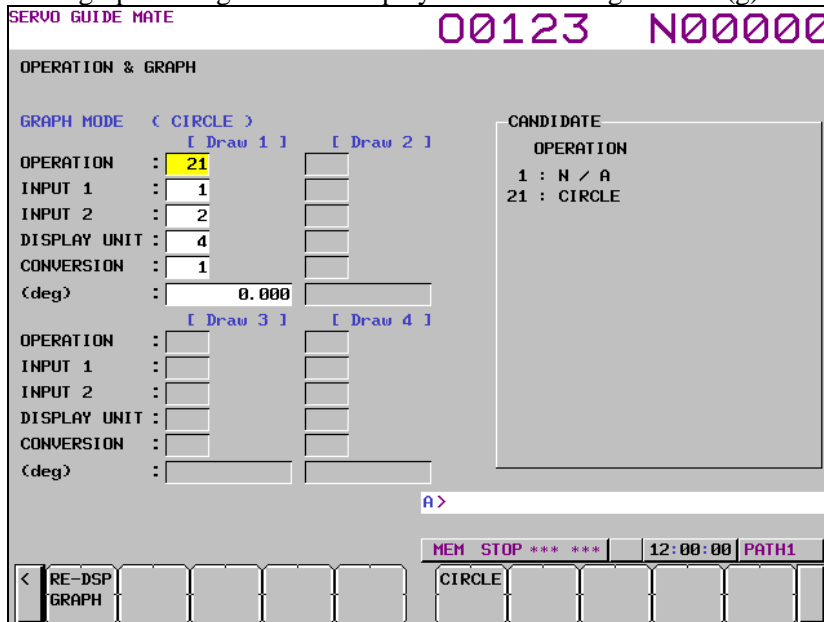



Fig. 1.9.1.3 (g)

- 2 Move the cursor to the parameter you want to set, by pressing the cursor key.
- 3 Enter data and the press the  key.
- 4 Repeat steps 2 and 3 until you set all the parameters.

- 5 Click the soft key [RE-DSPGRAPH].

Based on the new operation and graph settings, the wave display screen is displayed as shown Fig. 1.9.1.3 (h).

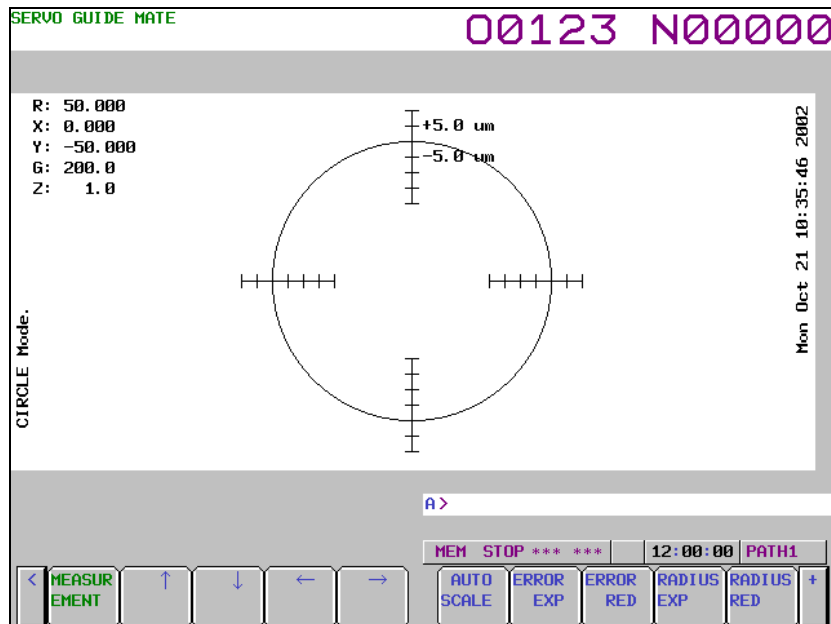

Fig. 1.9.1.3 (h)

### - Changing the scale screen

The procedure for changing the scale settings as necessary is described below.

- 1 Click the soft key [SCALE SET].

The scale setting screen is displayed as shown Fig. 1.9.1.3 (i).

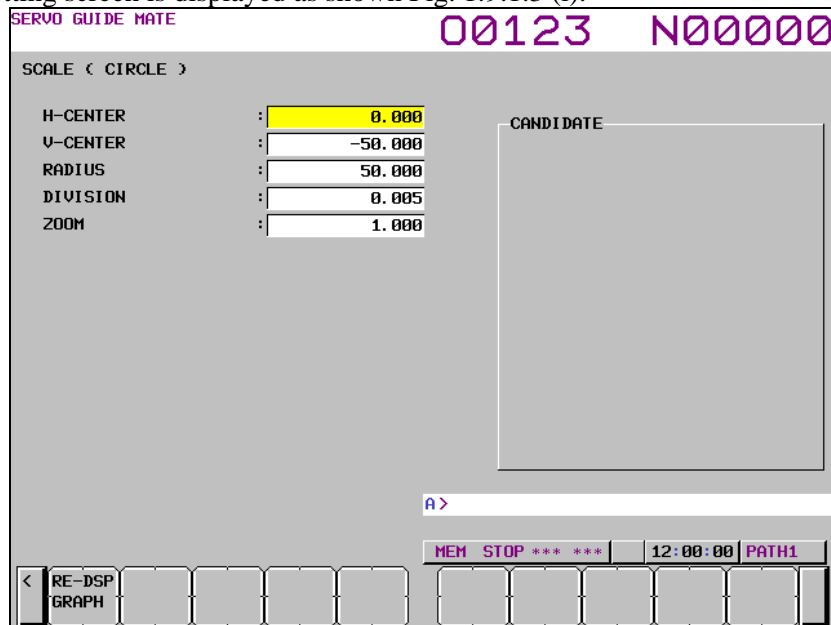



Fig. 1.9.1.3 (i)

- 2 Move the cursor to the parameter you want to set, by pressing the cursor key.

- 3 Enter data and the press the  key.

- 4 Repeat steps 2 and 3 until you set all the parameters.

- 5 Click the soft key [RE-DSPGRAPH].

Based on the new scale settings, the wave display screen is displayed as shown Fig. 1.9.1.3 (j).

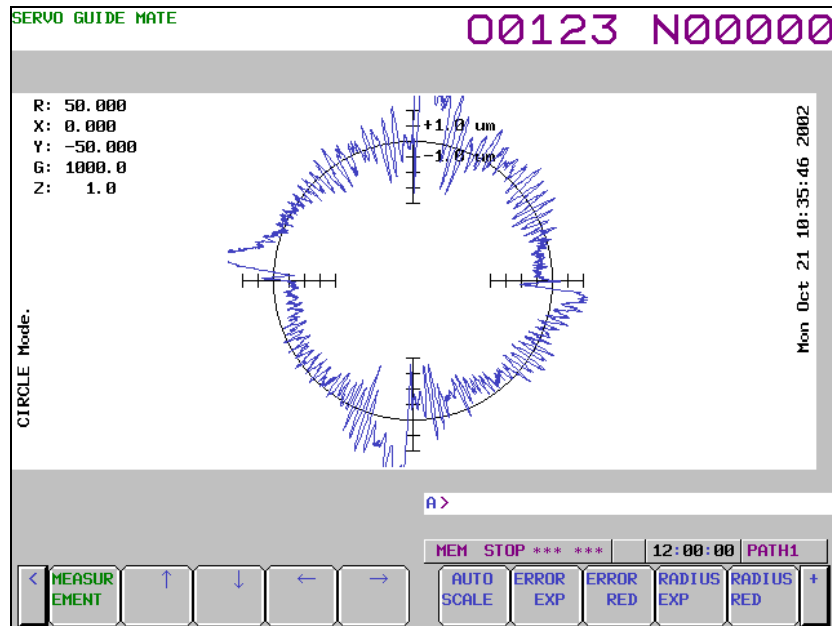

Fig. 1.9.1.3 (j)

### - Manipulating the Circle graph

By clicking the following soft keys, you can perform the operations corresponding to them.

[MEASUREMENT] : Performs a measurement-related operation.

[←] : Moves the center coordinate position to the left.

[→] : Moves the center coordinate position to the right.

[↑] : Moves the center coordinate position upward.

[↓] : Moves the center coordinate position downward.

[AUTO SCALE] : Enables auto scaling.

[ERROR EXP] : Expands the error display.

[ERROR RED] : Reduces the error display.

[RADIUSEXP] : Expands the radius.

[RADIUSRED] : Reduces the radius.

[DRAW 1UNDSP] : Sets whether or not to display Draw 1.

[ZOOM EXP] : Expands the zoom.

[ZOOM RED] : Reduces the zoom.

[OPE/G SET] : Sets operations and graphs.

[SCALE SET] : Sets scales.

[COM1 INPUT] : Inputs comment 1.

[COM2 INPUT] : Inputs comment 2.

[Y-TIME] : Switches to the Y-time graph.

[XY] : Switches to the XY graph.

[FOURIER] : Switches to the Fourier graph.

[BODE] : Switches to the Bode graph.

### - Performing measurement

When you click the soft key [MEASUREMENT], you can perform the operations corresponding to the menu items that follow.

[START] : Starts measurement.

[ORIGIN] : Sets the origin value.

[STOP] : Stops measurement.

[DATA IN] : Specifies measurement-related settings.





- **Changing measurement settings**

1 When you click the soft key [MEASUREMENT] and then the soft key [DATA IN], you can perform the operations corresponding to the menu items that follow.

2 Click the soft key [LIST].

The list screen is displayed as shown Fig. 1.9.1.3 (k).

To display any channel other than the one currently displayed, display the list screen for the desired channel by pressing the  or  key.

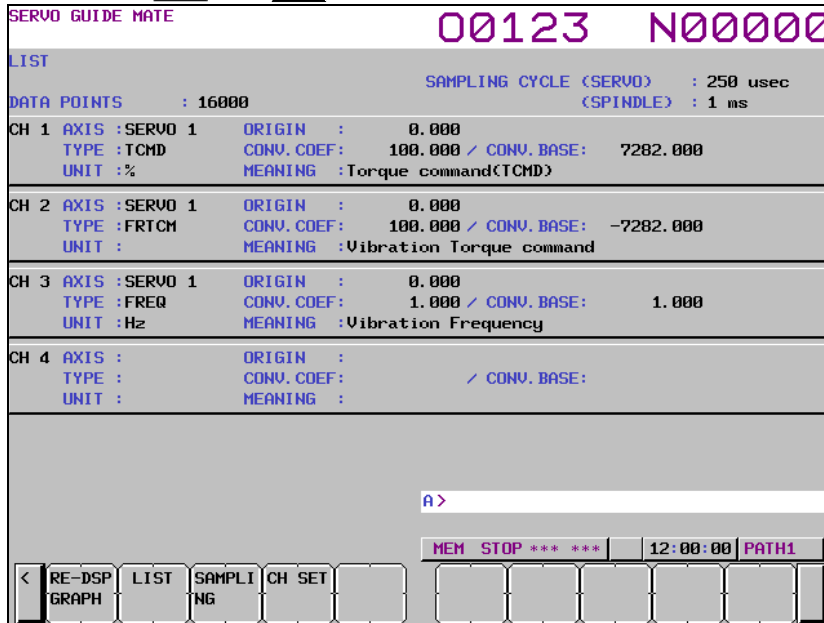

Fig. 1.9.1.3 (k)

3 Check the current settings on the list screen.

4 Click the soft key [SAMPLING].

The data-in screen is displayed as shown Fig. 1.9.1.3 (l).

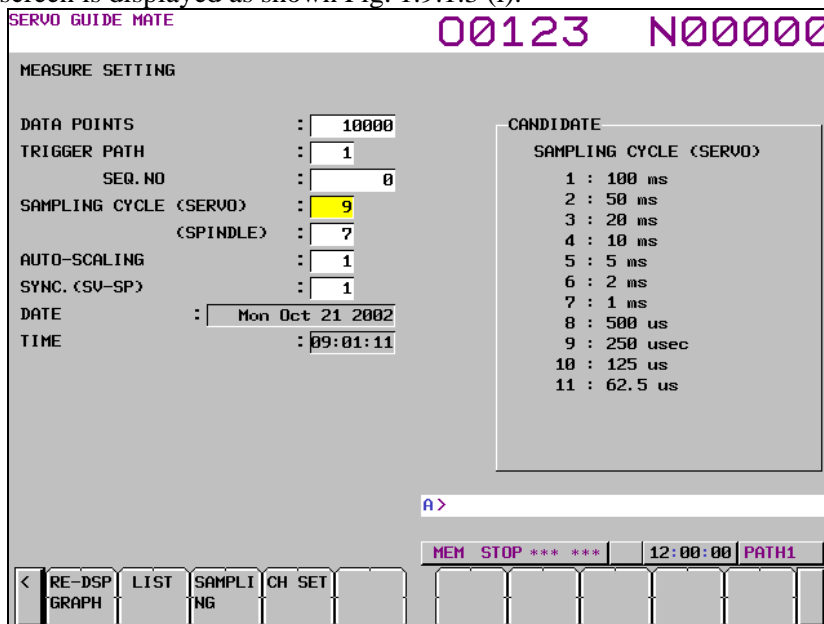





Fig. 1.9.1.3 (l)

5 Move the cursor to the parameter you want to set, by pressing the cursor key.

6 Enter data and the press the  key.

- 7 Repeat steps 5 and 6 until you set all the parameters.
- 8 Click the soft key [SET CHANNEL].

The channel setting screen is displayed as shown Fig. 1.9.1.3 (m).

To set any channel other than the one currently displayed, display the setting screen for the desired channel by pressing the  or  key.

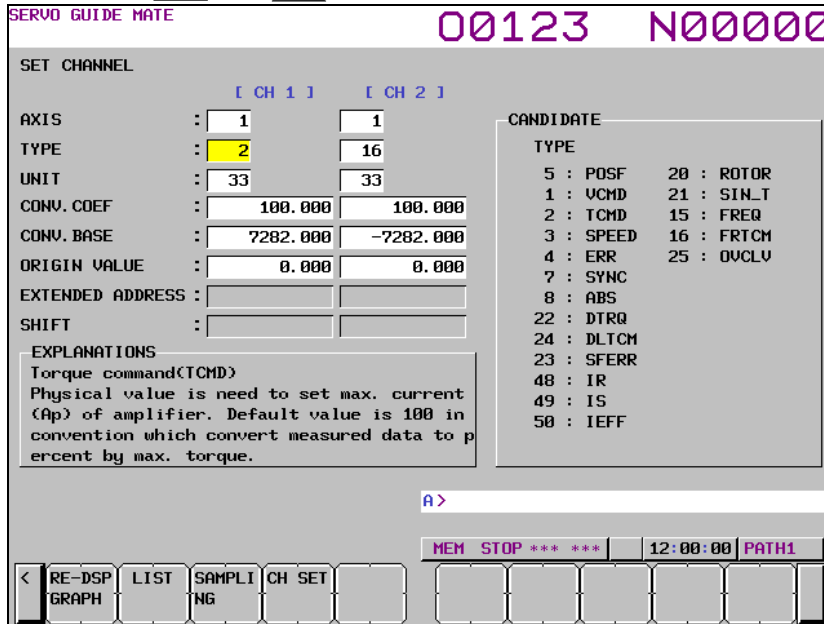



Fig. 1.9.1.3 (m)

- 9 Move the cursor to the parameter you want to set, by pressing the cursor key.
- 10 Enter data and the press the  key.
- 11 Repeat steps 9 and 10 until you set all the parameters.
- 12 Click the soft key [RE-DSPGRAPH].

The wave display screen is displayed as shown Fig. 1.9.1.3 (n).

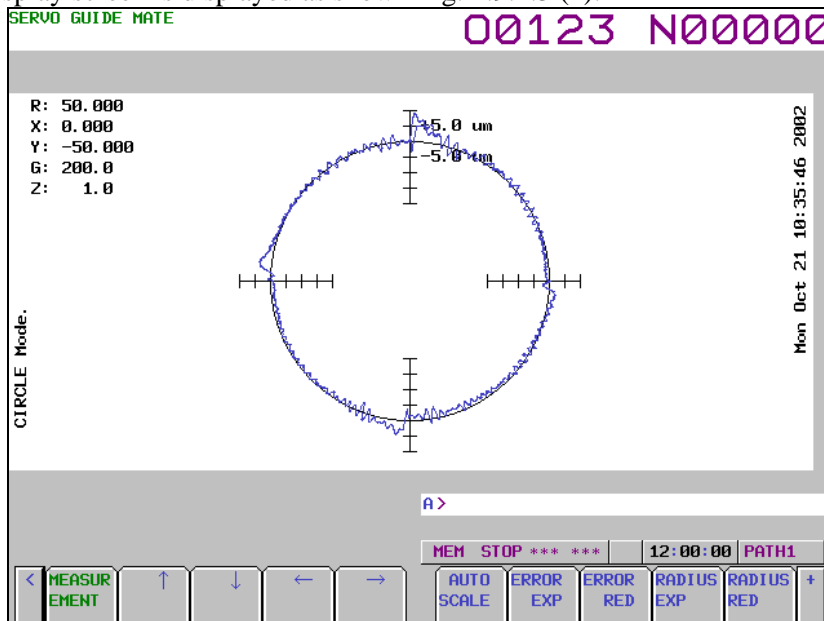

Fig. 1.9.1.3 (n)

- 13 The new settings will take effect next time you perform measurement. Change the operation/graph settings and scale settings according to the new channel settings.

## Explanation

### - Setting the data-in screen

See the Explanation section for the Y-time graph describing the setting of the data-in screen.

### - Setting the channel setting screen

See the Explanation section for the Y-time describing the setting of the channel setting screen.

### - Setting the operation and graph setting screen

The operation and graph setting screen lets you specify graph settings.

- Operation

The specifiable values are as shown in Table 1.9.1.3 (a), Circle graph operations.

An operation cannot be specified if it does not meet the graph display conditions defined in Table 1.9.1.3 (b), Circle graph conditions.

**Table 1.9.1.3 (a) Circle graph operations**

Input value	Operation name	Description
1	N/A	Not displayed.
21	Circle	Circle error display Input 1 is the horizontal axis, and input 2 is the vertical axis. The reference circle used to calculate the error is set on the scale page.

**Table 1.9.1.3 (b) Circle graph conditions**

Operation	Coordinate conversion	Input 1	Input 2	Remarks
21 : Circle	1 : Normal	Channel whose position has been measured	Channel whose position has been measured	
	2 : Polar	Channel whose position has been measured (only when the data unit is mm, $\mu$ m, or inch)	Channel whose position has been measured (only when the data unit is deg)	
	3 : Angular	Channel whose position has been measured	Channel whose position has been measured	

- Input 1

Specifiable values are sequential, with channel 1 being 1. The maximum value is the largest channel number for which measurement is set during the channel setting process. A value that does not meet the graph display conditions defined in Table 1.9.1.3 (b), Circle graph conditions cannot be specified in input 1.

- Input 2

Specifiable values are sequential, with channel 1 being 1. The maximum value is the largest channel number for which measurement is set during the channel setting process. A value that does not meet the graph display conditions defined in Table 1.9.1.3 (b), Circle graph conditions cannot be specified in input 2.

- Display unit

The specifiable value is 4 (mm) only.

- Coordinate conversion

Specifiable values are 1 (Normal; no coordinate conversion), 2 (Polar; coordinate conversion for polar coordinate interpolation), and 3 (Angular; coordinate conversion for angular axis control). The conditions for the specifiable coordinate conversion types are as shown in Table 1.9.1.3 (c), Corresponding Circle graph coordinate conversion types.

Table 1.9.1.3 (c) Corresponding Circle graph coordinate conversion types

Operation	Input 1	Input 2	Specifiable coordinate conversion
21 : Circle	Channel whose position has been measured	Channel whose position has been measured	1 : Normal
	Channel whose position has been measured (only when the data unit is mm, $\mu\text{m}$ , or inch)	Channel whose position has been measured (only when the data unit is deg)	2 : Polar
	Channel whose position has been measured	Channel whose position has been measured	3 : Angular

- Inclination  
Specify the inclination in degrees. The specified value is effective only when Angular (coordinate conversion for angular axis control) is specified as the coordinate conversion type.
- **Setting the scale screen**
  - Center  
Set the center coordinates of the circle (respective coordinates of the horizontal and vertical axes).
  - Radius  
Set the radius of the circle.
  - Division  
Set the scale of the circle display.
  - Zoom  
Set the zoom percentage when expanding the display in the direction of the center angle at the quadrant change point (direction change point for each axis). This is effective for getting a detailed view of quadrant protrusions. Under normal circumstances, set this value to 1.0.
- **Performing measurement**  
See the Explanation section for the Y-time graph describing the performing measurement.

---

## Limitation

See the Limitation section for the Y-time graph.

## 1.9.1.4 Fourier graph

---

This graph displays the frequency spectrum by performing digital Fourier conversion for the range of data displayed by the Y-time graph.

Up to four draws can be displayed at a time.

---

## Displaying and setting the Fourier graph

---

### Procedure

The procedure for displaying the measurement data is described below.

- 1 Display the Y-time graph according to the relevant procedure.
- 2 Click the soft key [FOURIER].  
The wave display screen is displayed as shown Fig. 1.9.1.4 (a).

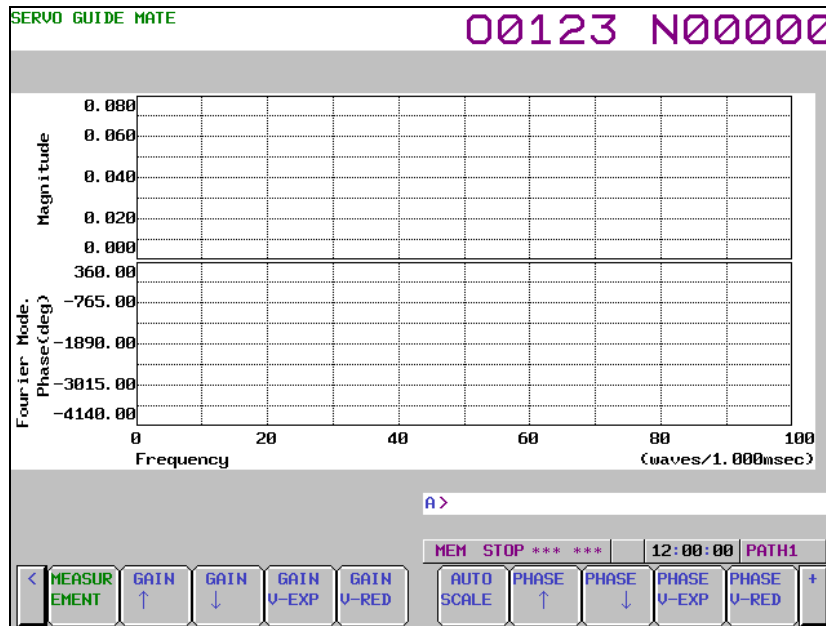

Fig. 1.9.1.4 (a)

- 3 Click the soft key [OPERATION & GRAPH].  
The operation and graph setting screen is displayed as shown Fig. 1.9.1.4 (b).

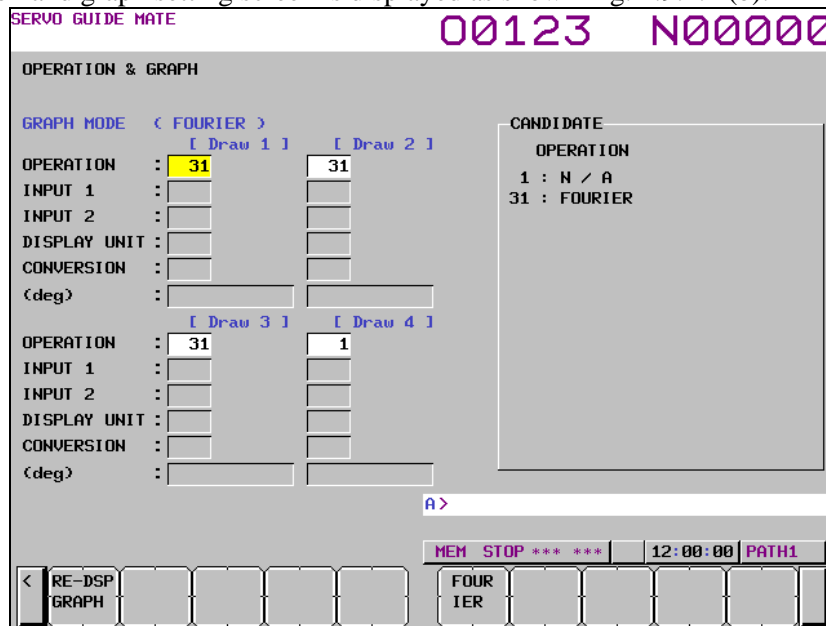



Fig. 1.9.1.4 (b)

- 4 Move the cursor to the parameter you want to set, by pressing the cursor key.
- 5 Enter data and the press the  key.
- 6 Repeat steps 4 and 5 until you set all the parameters.
- 7 Click the soft key [RE-DSPGRAPH].
- 8 Click the soft key [SCALE SET].  
The scale setting screen is displayed as shown Fig. 1.9.1.4 (c).

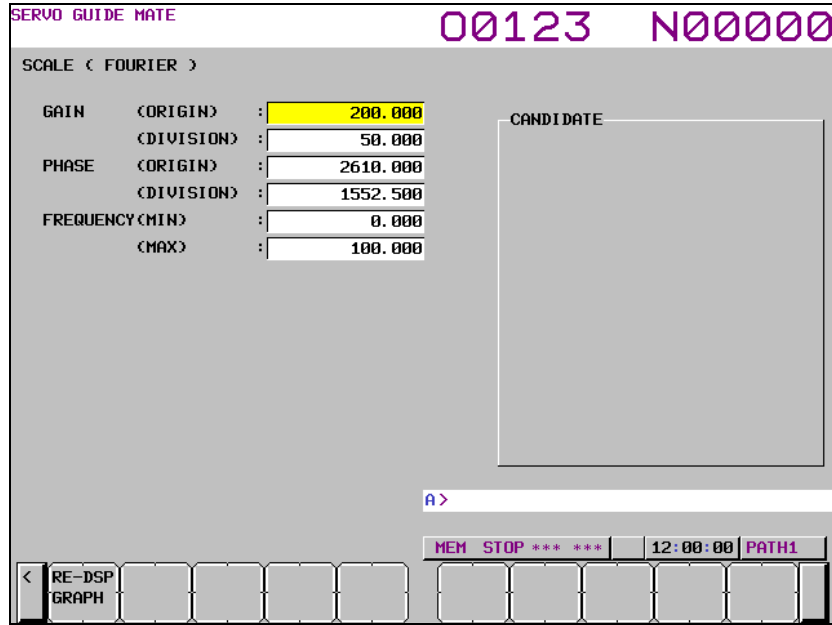



Fig. 1.9.1.4 (c)

- 9 Move the cursor to the parameter you want to set, by pressing the cursor key.
- 10 Enter data and the press the  key.
- 11 Repeat steps 9 and 10 until you set all the parameters.
- 12 Click the soft key [RE-DSPGRAPH].

The wave display screen is displayed as shown Fig. 1.9.1.4 (d).

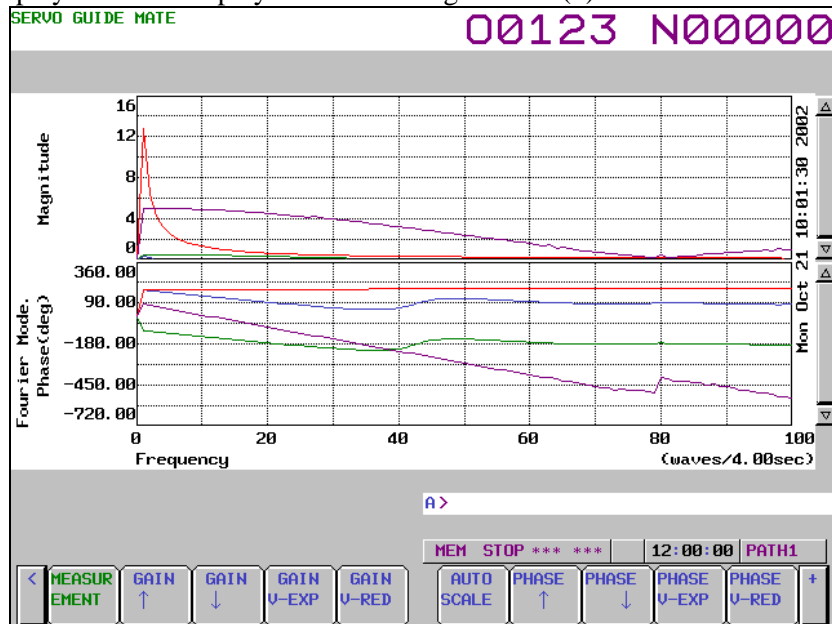

Fig. 1.9.1.4 (d)

**- Changing the operation and graph setting screen**

The procedure for changing the operation and graph setting screen as necessary is described below.

- 1 Click the soft key [OPERATION & GRAPH].

The operation and graph setting screen is displayed as shown Fig. 1.9.1.4 (e).

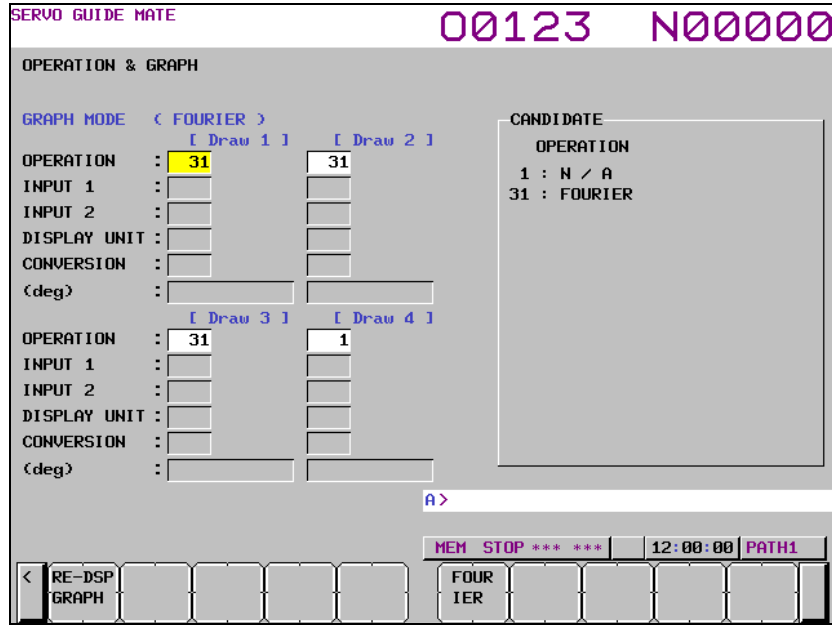



Fig. 1.9.1.4 (e)

- 2 Move the cursor to the parameter you want to set, by pressing the cursor key.
- 3 Enter data and the press the  key.
- 4 Repeat steps 2 and 3 until you set all the parameters.
- 5 Click the soft key [RE-DSPGRAPH].

Based on the new operation and graph settings, the wave display screen is displayed as shown Fig. 1.9.1.4 (f).

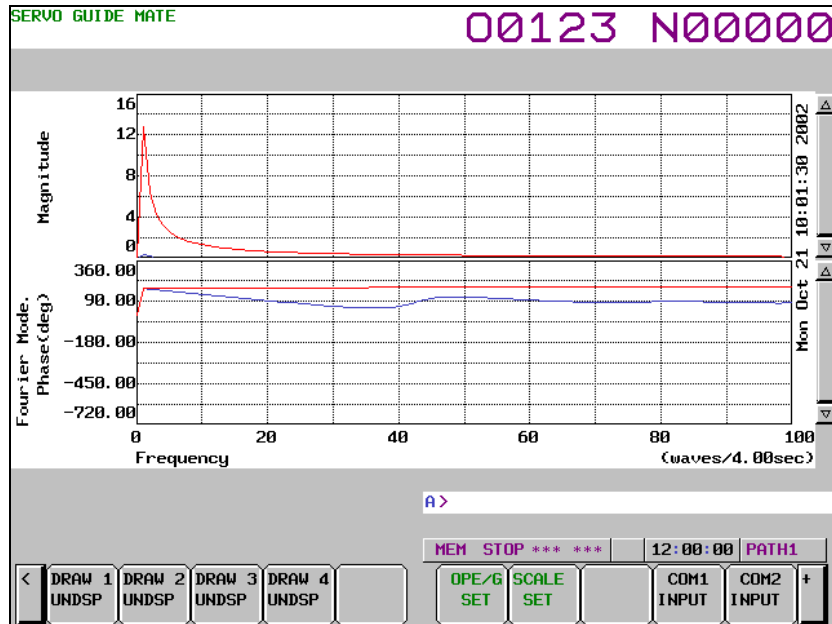

Fig. 1.9.1.4 (f)

**- Changing the scale screen**

The procedure for changing the scale settings as necessary is described below.

- 1 Click the soft key [SCALE SET].  
The scale setting screen is displayed as shown Fig. 1.9.1.4 (g).

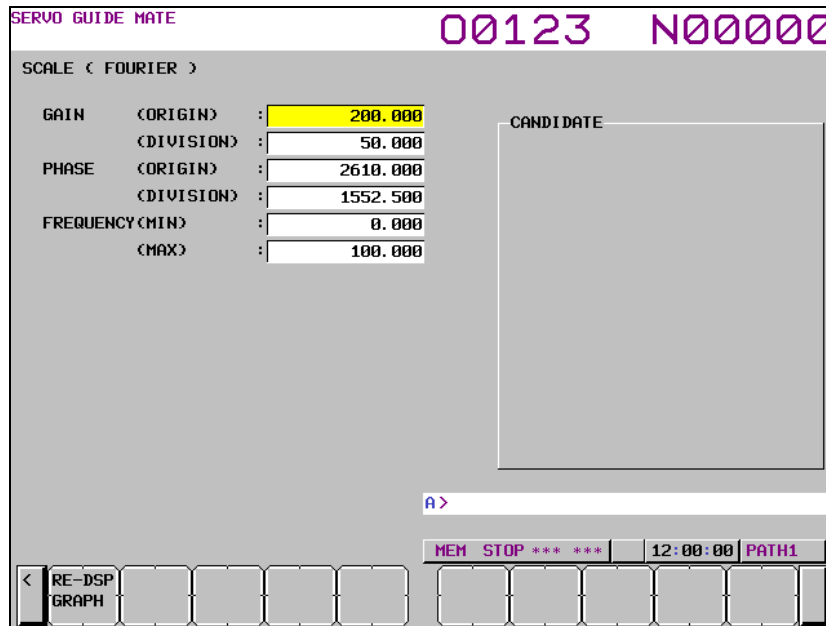



Fig. 1.9.1.4 (g)

- 2 Move the cursor to the parameter you want to set, by pressing the cursor key.
- 3 Enter data and the press the  key.
- 4 Repeat steps 2 and 3 until you set all the parameters.
- 5 Click the soft key [RE-DSPGRAPH].

Based on the new scale settings, the wave display screen is displayed as shown Fig. 1.9.1.4 (h).

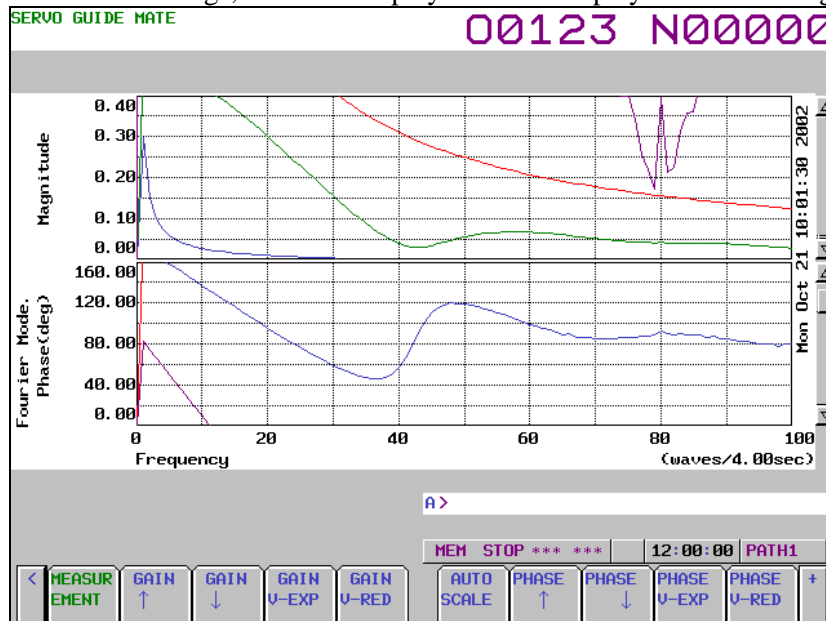

Fig. 1.9.1.4 (h)

### - Manipulating the Fourier graph

By clicking the following soft keys, you can perform the operations corresponding to them.

- [MEASUREMENT] : Performs a measurement-related operation.
- [GAIN ↑] : Shifts the gain graph downward.
- [GAIN ↓] : Shifts the gain graph upward.
- [GAIN V-EXP] : Expands the gain graph.
- [GAIN V-RED] : Reduces the gain graph.
- [AUTO SCALE] : Enables auto scaling.



[PHASE ↑]	: Shifts the phase graph downward.
[PHASE ↓]	: Shifts the phase graph upward.
[PHASE V-EXP]	: Expands the phase graph.
[PHASE V-RED]	: Reduces the phase graph.
[DRAW 1UNDSP]	: Sets whether or not to display Draw 1.
[DRAW 2UNDSP]	: Sets whether or not to display Draw 2.
[DRAW 3UNDSP]	: Sets whether or not to display Draw 3.
[DRAW 4UNDSP]	: Sets whether or not to display Draw 4.
[OPE/G SET]	: Sets operations and graphs.
[SCALE SET]	: Sets scales.
[COM1 INPUT]	: Inputs comment 1.
[COM2 INPUT]	: Inputs comment 2.
[Y-TIME]	: Switches to the Y-Time.
[XY]	: Switches to the XY graph.
[CIRCLE]	: Switches to the Circle graph.
[BODE]	: Switches to the Bode graph.

## Explanation

### - Setting the operation and graph setting screen

The operation and graph setting screen lets you specify up to four graph settings per draw.

- Operation

The specifiable values are as shown in Table 1.9.1.4 (a), Fourier graph operations.

An operation cannot be specified if it does not meet the graph display conditions defined in Table 1.9.1.4 (b), Fourier graph conditions.

**Table 1.9.1.4 (a) Fourier graph operations**

Input value	Operation name	Description
1	N/A	Not displayed.
31	Fourier	Displays the frequency spectrum by performing digital Fourier conversion.

**Table 1.9.1.4 (b) Fourier graph conditions**

Operation	Condition	Remarks
31 : Fourier	Draws of the Y-time graph correspond to those of the Fourier graph on a one-to-one basis. The Fourier operation can be set only when the corresponding Y-time graph draw is effective.	

### - Setting the scale screen

- Start point

Set gain and phase data values for the center of the graph.

- Division

Set the value of one grid.

- Frequency

Set the minimum and maximum values of the horizontal axis. Since the unit is dependent on the time range selected for the Y-time graph, 1 is not necessarily equal to 1 Hz.

(Example) When a 0.1-second time range is selected, 1 is equal to 1 Hz.

## Limitation

See the Limitation section for the Y-time graph.

### 1.9.1.5 Bode graph

This graph displays a Bode diagram for the measurement data in the form of a horizontal axis logarithm graph.

Only one draw can be displayed at a time.

#### Displaying and setting the Bode graph

##### Procedure

To display the Bode graph, set the parameters for automatic vibration (disturbance input function) using servo software.

The procedure for displaying the measurement data is described below.

- 1 Press the  function key.
- 2 Press and hold this key until [PARAMETER] appears.
- 3 Set the following parameters.
 

No.2326 (Disturbance input gain)	Recommended value: 500
No.2327 (Start frequency of disturbance input)	Recommended value: 10
No.2328 (End frequency of disturbance input)	Recommended value: 1000
No.2329 (Number of disturbance input measurement points)	Recommended value : 3
- 4 When bit 7 (DSTIN) of parameter No. 2270 changes from 0 to 1, disturbance input starts. This operation needs to be performed to start measurement, so a program that changes bit 7 (DSTIN) of parameter No. 2270 from 0 to 1 with program data input (G10) must have been created in advance.

Programming example: When the Z-axis (third axis) is vibrated (when bit 4 (G1B) of parameter 3454 is 1)

O1234	
N1G10L52 ;	Parameter input mode (this N number is used for a trigger.)
N2270 P3 Q7 R1;	Set DSTIN (bit 7 of parameter No. 2270).
G11 ;	Cancel the parameter input mode.
N2G04X10.;	Wait for completion of vibration.
N99G10L52 ;	Parameter input mode
N2270 P3 Q7 R0;	Clear DSTIN (bit 7 of parameter No. 2270).
G11 ;	Cancel the parameter input mode.
M30	

- 5 Press the continuous menu key  several times until [SERVO GUIDE MATE] is displayed.
- 6 Click the soft key [SERVO GUIDE MATE].
- 7 Click the soft key [BODE].

The wave display screen is displayed as shown Fig. 1.9.1.5 (a).

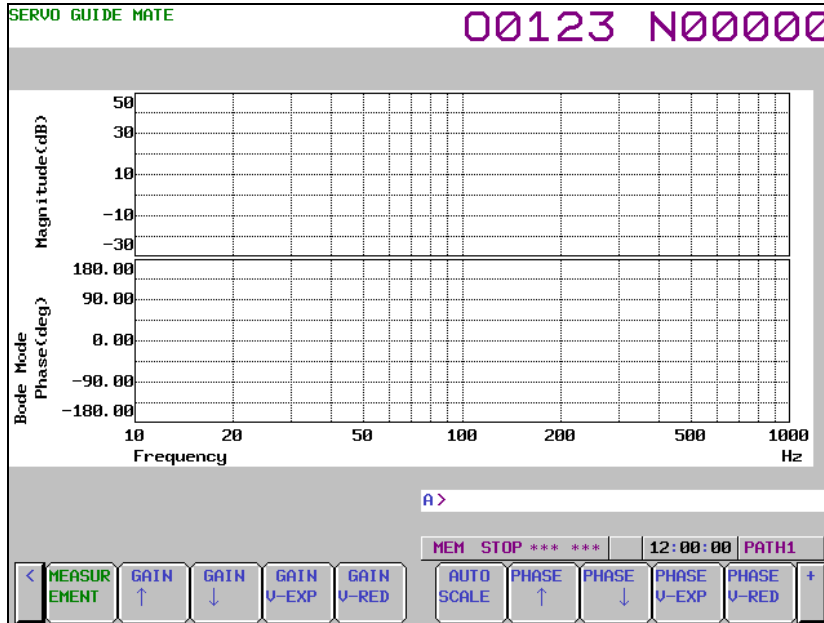

Fig. 1.9.1.5 (a)

- 8 Click the soft key [MEASUREMENT].
- 9 Click the soft key [DATA IN].
- 10 Click the soft key [SAMPLING].

The data-in screen is displayed as shown Fig. 1.9.1.5 (b).

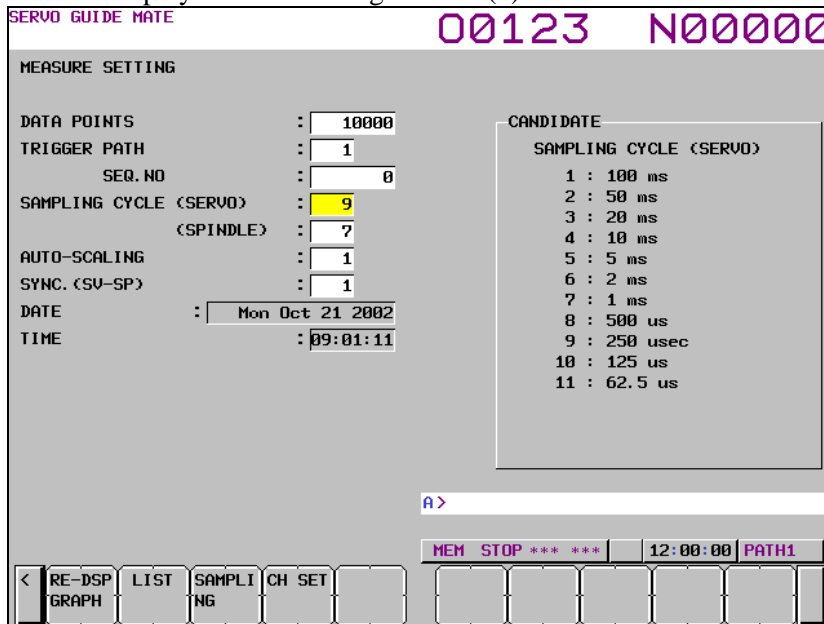





Fig. 1.9.1.5 (b)

- 11 Move the cursor to the parameter you want to set, by pressing the cursor key.
- 12 Enter data and the press the  key.
- 13 Repeat steps 11 and 12 until you set all the parameters.
- 14 Click the soft key [SET CHANNEL].

The channel setting screen is displayed as shown Fig. 1.9.1.5 (c).

To set any channel other than the one currently displayed, display the setting screen for the desired channel by pressing the  or  key.

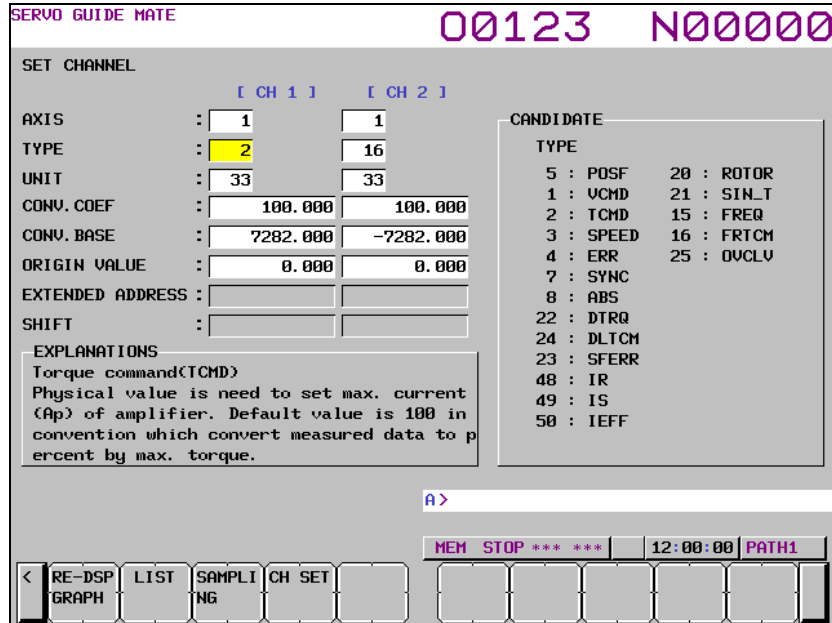

Fig. 1.9.1.5 (c)

- 15 Move the cursor to the parameter you want to set, by pressing the cursor key.
- 16 Enter data and the press the  key.
- 17 Repeat steps 15 and 16 until you set all the parameters.  
To display the Bode graph, make the channel settings of the Bode graph in Table 1.9.1.5 (a). At this time, be sure to disable channel 4 (axis for channel 4 is 0).

Table 1.9.1.5 (a) Bode graph channel settings

	Channel 1	Channel 2	Channel 3
<b>AXIS</b>	Specify the same servo motor axis.		
<b>TYPE</b>	2 : TCMD	16 : FRTCM	15 : FREQ
<b>UNIT</b>	33 : %	33 : A(p)	32 : Hz
<b>CONV.COEF</b>	100	100	1
<b>CONV.BASE</b>	7282	-7282	1
<b>ORIGIN VALUE</b>	0	0	0

Set a trigger that corresponds to the program prepared in step 4.  
(In the programming example, set N number for a trigger to 1.)

- 18 Click the soft key [RE-DSPGRAPH].
- 19 Click the soft key [OPERATION & GRAPH].  
The operation and graph setting screen is displayed as shown Fig. 1.9.1.5 (d).

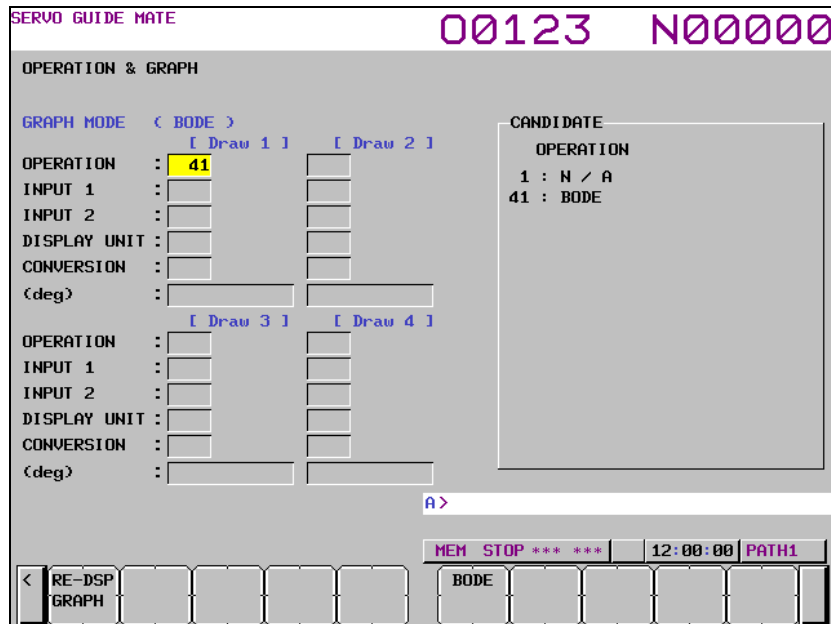



Fig. 1.9.1.5 (d)

- 20 Move the cursor to the parameter you want to set, by pressing the cursor key.
- 21 Enter data and the press the  key.
- 22 Click the soft key [RE-DSPGRAPH].
- 23 Click the soft key [SCALE SET].

The scale setting screen is displayed as shown Fig. 1.9.1.5 (e).

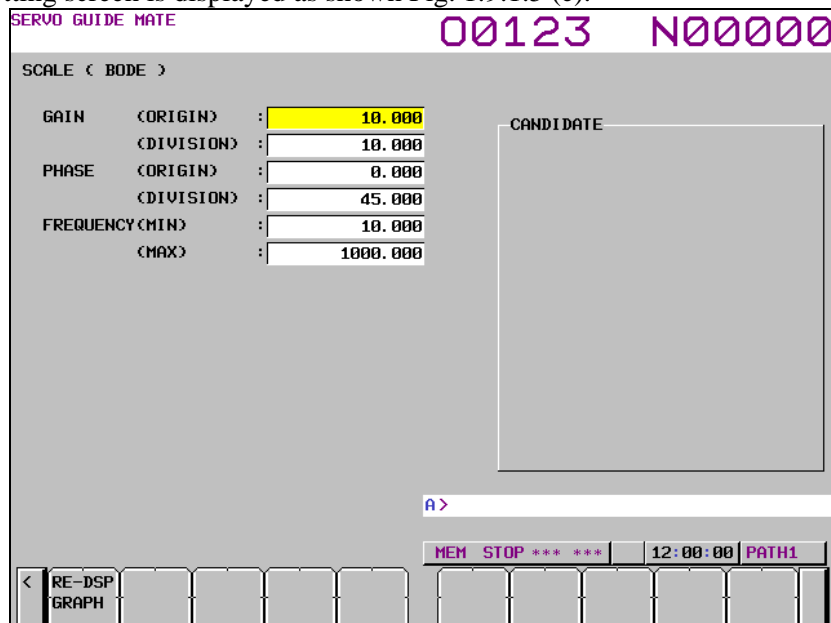



Fig. 1.9.1.5 (e)

- 24 Move the cursor to the parameter you want to set, by pressing the cursor key.
- 25 Enter data and the press the  key.
- 26 Repeat steps 21 and 22 until you set all the parameters.
- 27 Click the soft key [RE-DSPGRAPH].
- 28 Click the soft key [MEASUREMENT].
- 29 Click the soft key [START].
- 30 Perform automatic operation of the program prepared in step 4.

28 When the measurement is completed, the wave display screen is displayed as shown Fig. 1.9.1.5 (f).

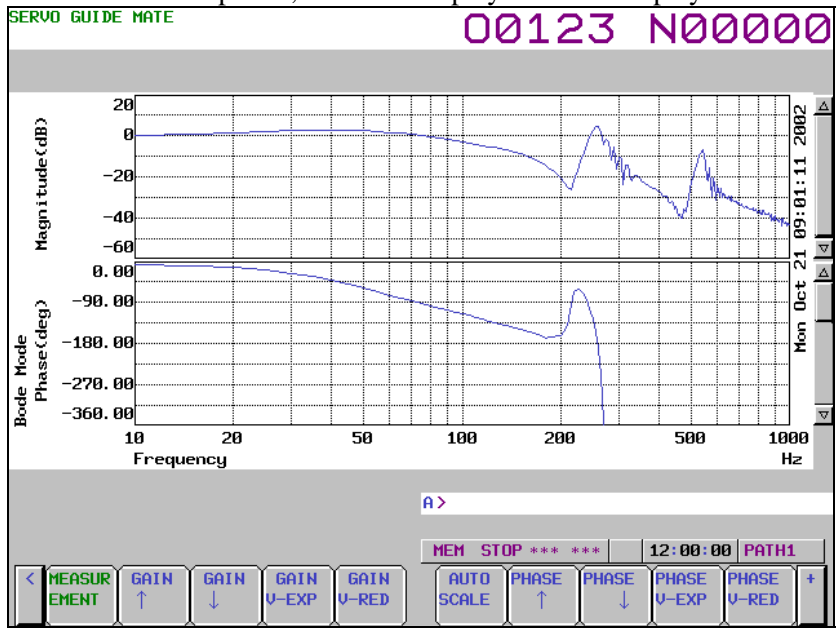

Fig. 1.9.1.5 (f)

**- Changing the operation and graph setting screen**

The procedure for changing the operation and graph setting screen as necessary is described below.

1 Click the soft key [OPERATION & GRAPH].

The operation and graph setting screen is displayed as shown Fig. 1.9.1.5 (g).

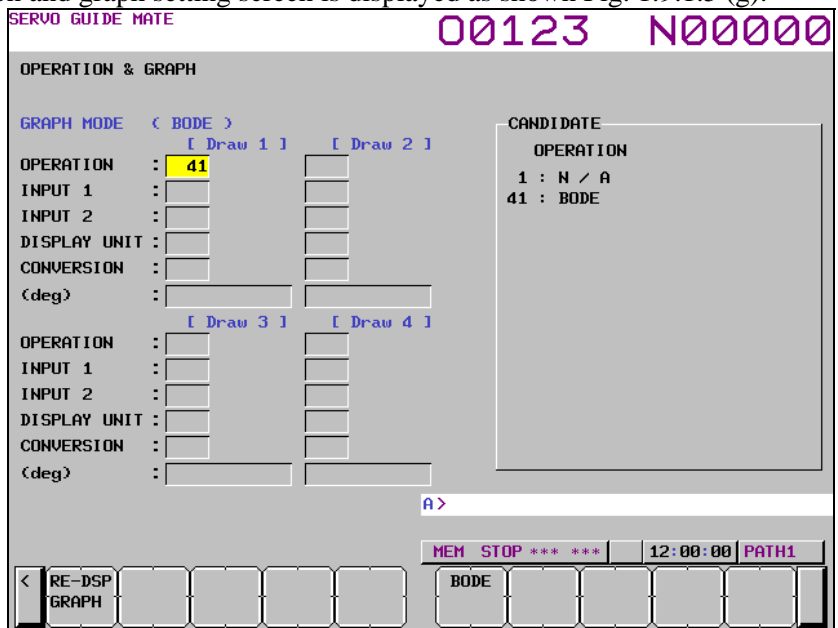



Fig. 1.9.1.5 (g)

2 Move the cursor to the parameter you want to set, by pressing the cursor key.

3 Enter data and the press the  key.

4 Click the soft key [RE-DSPGRAPH].

Based on the new operation and graph settings, the wave display screen is displayed as shown Fig. 1.9.1.5 (h).

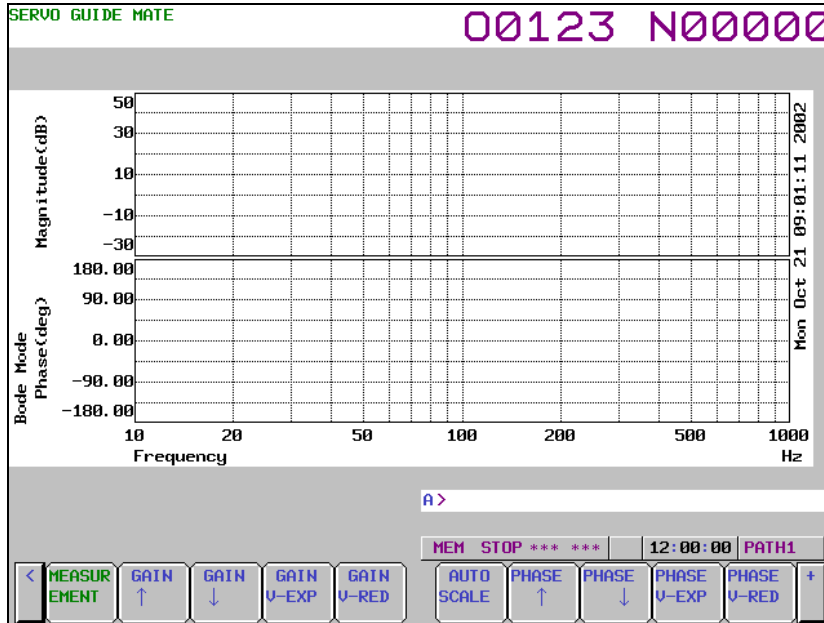

Fig. 1.9.1.5 (h)

**- Changing the scale screen**

The procedure for changing the scale settings as necessary is described below.

- 1 Click the soft key [SCALE SET].

The scale setting screen is displayed as shown Fig. 1.9.1.5 (i).

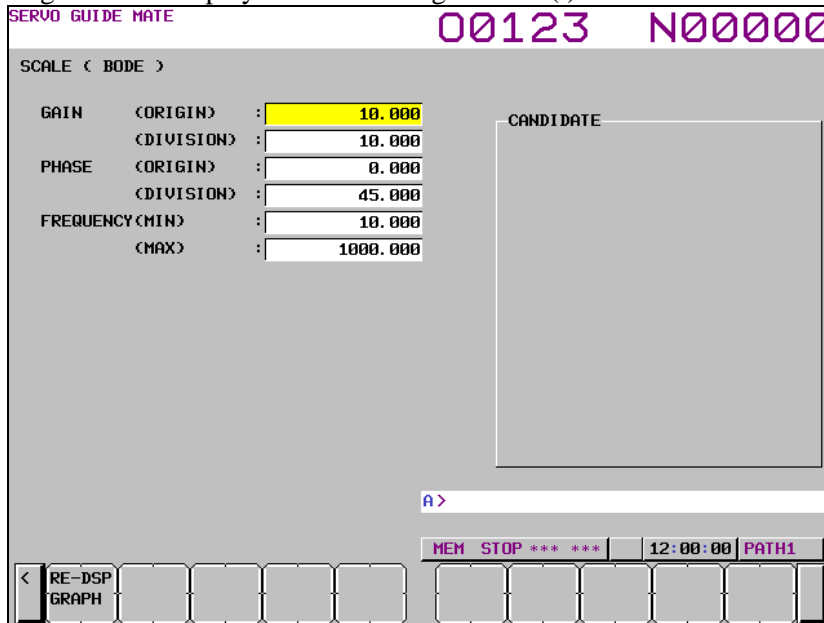



Fig. 1.9.1.5 (i)

- 2 Move the cursor to the parameter you want to set, by pressing the cursor key.
- 3 Enter data and the press the  key.
- 4 Repeat steps 2 and 3 until you set all the parameters.
- 5 Click the soft key [RE-DSPGRAPH].

Based on the new scale settings, the wave display screen is displayed as shown Fig. 1.9.1.5 (j).

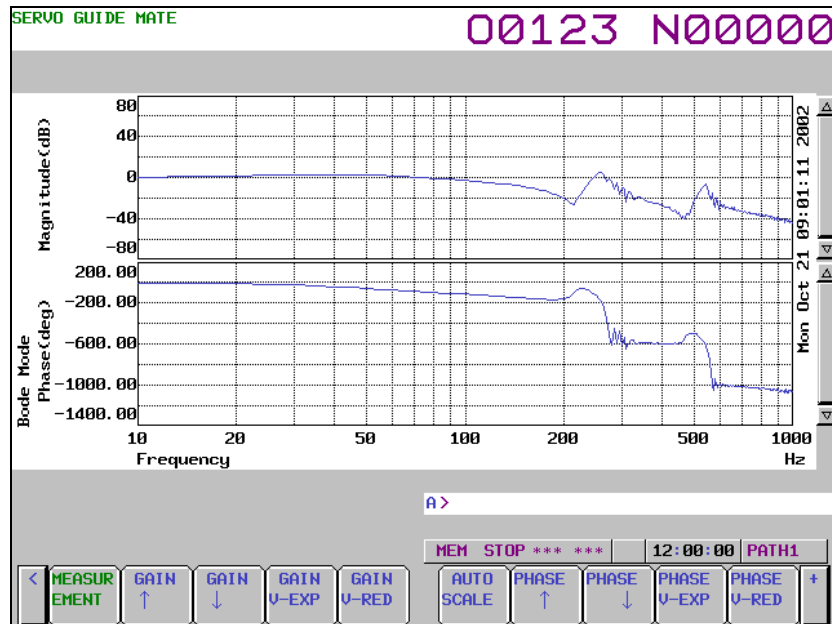

Fig. 1.9.1.5 (j)

### - Manipulating the Bode graph

By clicking the following soft keys, you can perform the operations corresponding to them.

- [MEASUREMENT] : Performs a measurement-related operation.
- [GAIN ↑] : Shifts the gain graph downward.
- [GAIN ↓] : Shifts the gain graph upward.
- [GAIN V-EXP] : Expands the gain graph.
- [GAIN V-RED] : Reduces the gain graph.
- [AUTO SCALE] : Enables auto scaling.
- [PHASE ↑] : Shifts the phase graph downward.
- [PHASE ↓] : Shifts the phase graph upward.
- [PHASE V-EXP] : Expands the phase graph.
- [PHASE V-RED] : Reduces the phase graph.
- [DRAW 1UNDSP] : Sets whether or not to display Draw 1.
- [OPE/G SET] : Sets operations and graphs.
- [SCALE SET] : Sets scales.
- [COM1 INPUT] : Inputs comment 1.
- [COM2 INPUT] : Inputs comment 2.
- [Y-TIME] : Switches to the Y-Time.
- [XY] : Switches to the XY graph.
- [CIRCLE] : Switches to the Circle graph.
- [FOURIER] : Switches to the Fourier graph.

### - Performing measurement

When you click the soft key [MEASUREMENT], you can perform the operations corresponding to the menu items that follow.

- [START] : Starts measurement.
- [ORIGIN] : Sets the origin value.
- [STOP] : Stops measurement.
- [DATA IN] : Specifies measurement-related settings.



### - Changing measurement settings

- 1 When you click the soft key [MEASUREMENT] and then the soft key [DATA IN], you can perform the operations corresponding to the menu items that follow.



- 2 Click the soft key [LIST].

The list screen is displayed as shown Fig. 1.9.1.5 (k).

To display any channel other than the one currently displayed, display the list screen for the desired channel by pressing the  or  key.

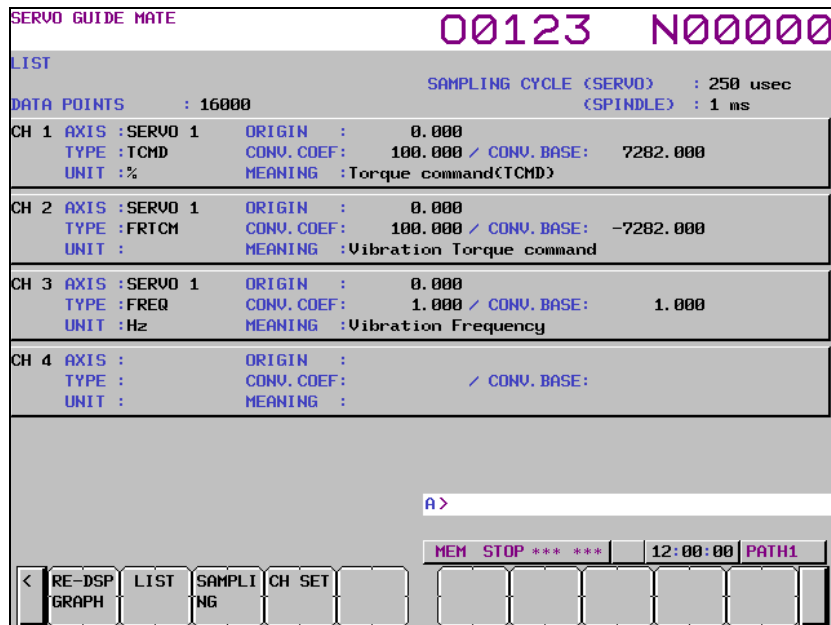

Fig. 1.9.1.5 (k)

- 3 Check the current settings on the list screen.

- 4 Click the soft key [SAMPLING].

The data-in screen is displayed as shown Fig. 1.9.1.5 (l).

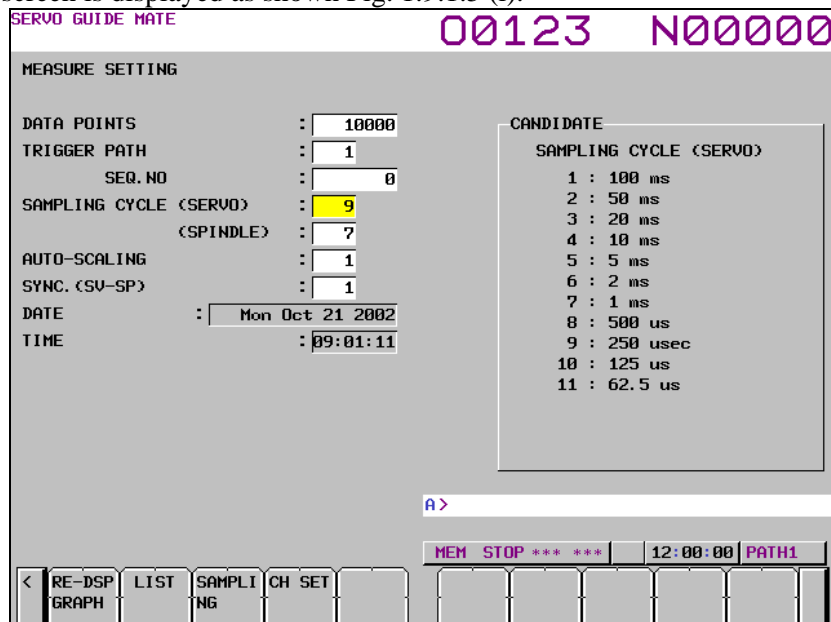



Fig. 1.9.1.5 (l)



- 5 Move the cursor to the parameter you want to set, by pressing the cursor key.

- 6 Enter data and the press the  key.

- 7 Repeat steps 5 and 6 until you set all the parameters.

- 8 Click the soft key [SET CHANNEL].

The channel setting screen is displayed as shown Fig. 1.9.1.5 (m).

To set any channel other than the one currently displayed, display the setting screen for the desired channel by pressing the  or  key.

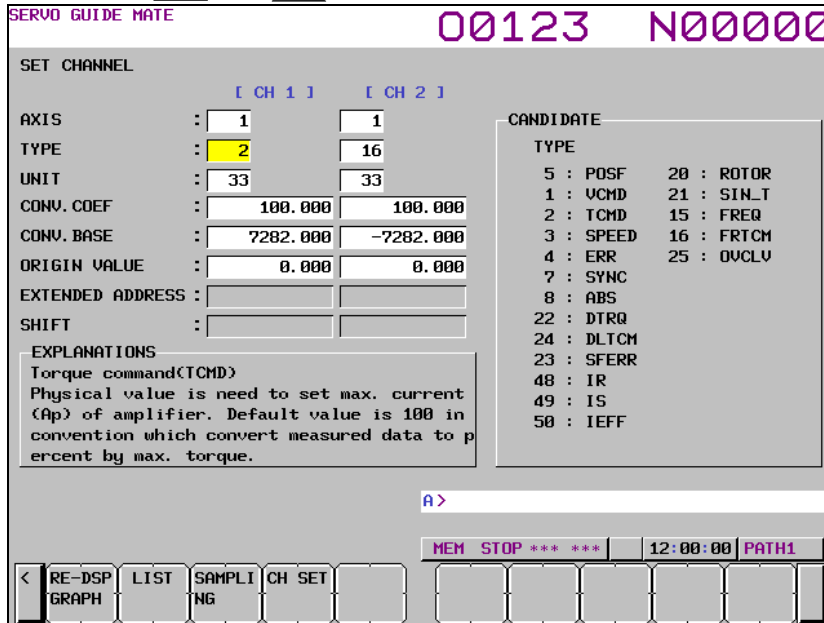



Fig. 1.9.1.5 (m)

- 9 Move the cursor to the parameter you want to set, by pressing the cursor key.
- 10 Enter data and the press the  key.
- 11 Repeat steps 9 and 10 until you set all the parameters.
- 12 Click the soft key [RE-DSPGRAPH].

The wave display screen is displayed as shown Fig. 1.9.1.5 (n).

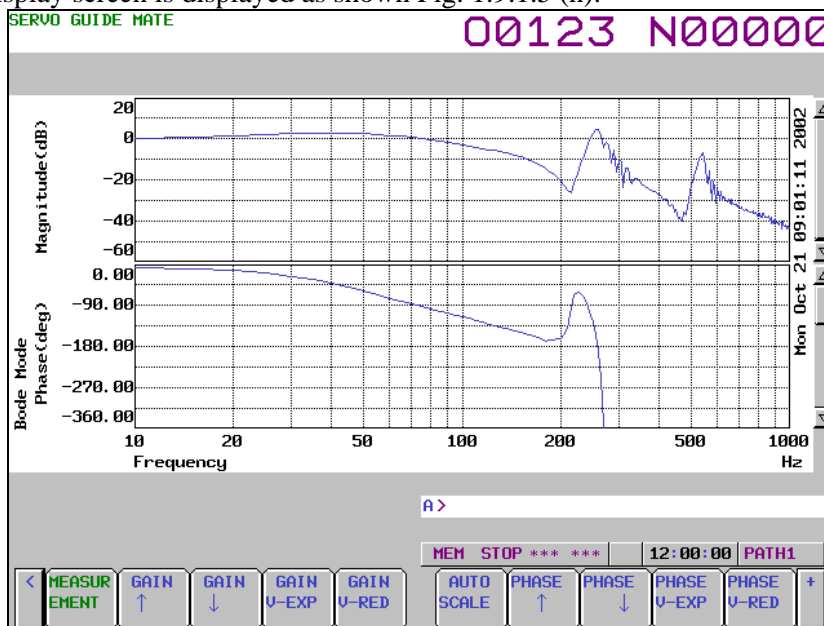

Fig. 1.9.1.5 (n)

- 13 The new settings will take effect next time you perform measurement. Change the operation/graph settings and scale settings according to the new channel settings.

**Explanation**

- **Setting the data-in screen**

See the Explanation section for the Y-time graph describing the setting the data-in screen.

- **Setting the channel setting screen**

See the Explanation section for the Y-time graph describing the setting the channel setting screen.

- **Setting the operation and graph setting screen**

The operation and graph setting screen lets you specify graph settings.

• Operation

The specifiable values are as shown in Table 1.9.1.5 (b), Bode graph operations.

An operation cannot be specified if it does not meet the graph display conditions defined in Table 1.9.1 (c), Bode graph conditions.

**Table 1.9.1.5 (b) Bode graph operations**

Input value	Operation name	Description
1	N/A	Not displayed.
41	Bode	Displays a Bode diagram in the form of a horizontal axis logarithm graph.

**Table 1.9.1 (c) Bode graph conditions**

Operation	Condition			
41 : Bode	The measurement and channel settings must meet the following conditions.			
		CHANNEL 1	CHANNEL 2	CHANNEL 3
	<b>AXIS</b>	Specify the same servo motor axis.		
	<b>TYPE</b>	2 : TCMD	16 : FRTCM	15 : FREQ
	<b>UNIT</b>	33 : %	33 : %	32 : Hz
	<b>CONV.COEF</b>	100	100	1
	<b>CONV.BASE</b>	7282	-7282	1
	<b>ORIGIN VALUE</b>	0	0	0
Channel 4 must be disabled (channel 4 axis must be set to0).				

- **Setting the scale screen**

• Start point

Set gain and phase data values for the center of the graph.

• Division

Set the value of one grid.

• Frequency

Set the minimum and maximum values of the horizontal axis. The unit is Hz.

- **Performing measurement**

See the Explanation section for the Y-time graph describing the performing measurement.

**Limitation**

See the Limitation section for the Y-time graph.

**1.9.1.6 Parameters**

	#7	#6	#5	#4	#3	#2	#1	#0
2270	DSTIN	DSTTAN	DSTWAV	DSTMV	ACREF			

[Input type] Parameter input

[Data type] Bit axis

**#3 ACREF** Adaptive resonance elimination filter

0: Disabled

1: Enabled

When this function is enabled, disable it temporarily and then use the disturbance input function.

(This is because the resonance elimination filter changes in response to the vibration of the axis even if the vibration is caused by the disturbance input function.)

**#4 DSTMV** Usually, set 0.**#5 DSTWAV** The input waveform of disturbance input is:

0: Sine wave.

1: Square wave.

Usually, set 0.

**#6 DSTTN** Disturbance is:

0: Input for one axis only.

1: Input for both the L and M axes.

Usually, set 0. To be set only for the L axis side of synchronous axes or tandem axes.

**#7 DSTIN** Disturbance input

0: Stop

1: Start

Disturbance input starts on the rising edge from 0 to 1.

2326

Disturbance input gain

[Input type] Parameter input

[Data type] Word axis

[Unit of data] TCMD unit (maximum amplifier current: 7282)

[Valid data range] 0 to 7282

First, set about 500 to apply vibration to the machine so that light sound is generated.

2327

Start frequency of disturbance input

[Input type] Parameter input

[Data type] Word axis

[Unit of data] Hz

[Valid data range] 1 to 2000

[Guide setting] 10

Set the frequency at which vibration starts.

2328

End frequency of disturbance input

[Input type] Parameter input

[Data type] Word axis

[Unit of data] Hz

[Valid data range] 1 to 2000

[Guide setting] 1000

Set the frequency at which vibration terminates.

2329

Number of disturbance input measurement points

[Input type] Parameter input

[Data type] Word axis

[Guide setting] 3

Set the number of measurement points by the disturbance input function (number of vibrations).

For details on the disturbance input function, refer to the PARAMETER MANUAL (B-65270EN) for the servo motor.

	#7	#6	#5	#4	#3	#2	#1	#0
3454				G1B				

[Input type] Parameter input

[Data type] Bit path

- #4 G1B** In programmable parameter input, the change command for a particular bit parameter is:  
 0: Disabled.  
 1: Enabled. (The bit number is specified by Q\_.)



## 1.10 MAINTENANCE INFORMATION SCREEN

The maintenance information screen is provided to record the history of maintenance performed by a service person of FANUC or machine tool builder.

The screen has the following features:

- MDI alphabetical input is allowed.  
(Half-size kana input is for Japanese display only.)
- The recording screen can be scrolled in units of lines.
- Edited maintenance information can be input and output.
- Records are stored in Flash ROM.
- Double-byte (shift JIS) codes can be displayed.

### 1.10.1 Displaying the Maintenance Information Screen

1. Press function key .
2. Press continuous menu key  several times until soft key [M-INFO] is displayed.
3. Press the soft key [M-INFO]. The maintenance information screen appears.

When selected, the maintenance screen shows the latest information.

The status (mode, number of empty character spaces, cursor line, column number) is displayed at the bottom of the screen.

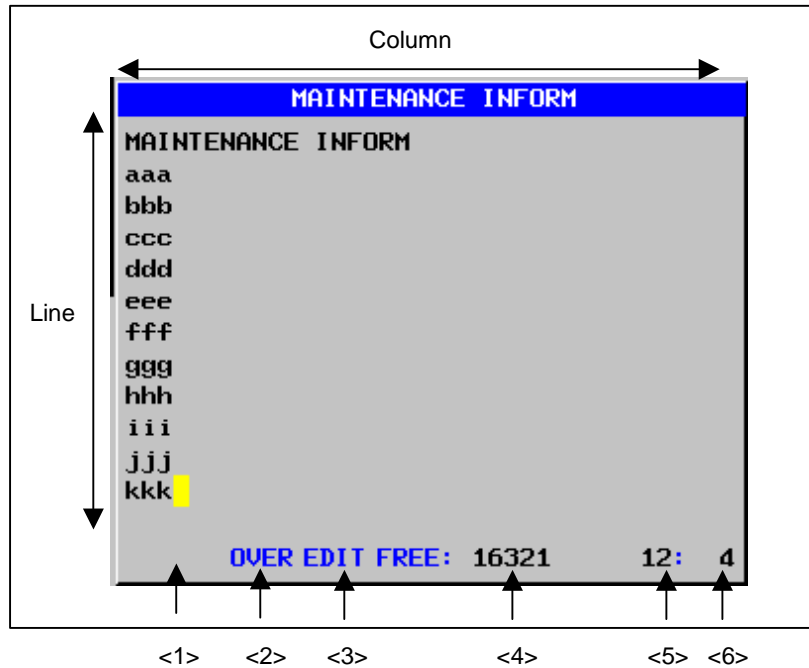

Fig. 1.10.1 (a) MAINTENANCE INFORMATION screen

## Status display

- <1> Kana/alphabetic  
KN: Half-size kana input mode.  
ABC: English input mode
- <2> OVER / INSERT  
OVER: Overwrite mode  
INSERT: Insert input mode.
- <3> EDIT / READ  
EDIT: Editing allowed  
READ: Editing inhibited
- <4> Number of empty character spaces  
Number of empty character spaces as half-size characters
- <5> Current cursor line  
Position of the line on which the cursor is currently located.
- <6> Current cursor column  
Position of the column at which the cursor is currently located.

**NOTE**

The numbers of lines and columns that can be displayed by each LCD are:

- 10.4" display unit: 37 characters × 12 lines
- 8.4" display unit: 38 characters × 11 lines
- 15" display unit: 38 characters × 19 lines

## 1.10.2 Operating the Maintenance Information Screen





The maintenance information screen has view mode and edit mode, which are selected by pressing the soft key [END] or [EDIT].

Initially, view mode is selected. To start editing, select edit mode by pressing the soft keys [(OPRT)] and [EDIT]. When the editing is completed, press the soft key [END] key. Then, select soft key [SAVE] or [QUIT]. Unless soft key [SAVE] is selected, the edited data will be lost at next power-up.

To scroll the screen showing the recorded information, press a cursor keys or page keys on the MDI panel.

The following keys are used for editing (character input) and viewing:

**Table 1.10.2 (a) Table of (edit) operations on the maintenance information screen**

Mode	Key	Description
View	Soft key [EDIT]	Allows editing.
	[JUMP]	Displays the beginning or the end.
	Cursor keys	Scrolls the screen up or down.
	Page keys	Scrolls the screen up or down in units of whole screens.
Edit	Soft key [END]	Ends editing. Select whether to save the edited data.
	[KN/ABC]	Switches between half-size kana input and alphabetic input modes. (Supports Japanese display only.)
	[CLEAR ALL]	Clears all maintenance information. (This key is enabled when the bit 7 (MDC) of parameter No. 3116 is set to 1.)
	[I/O]	Reads or punches the maintenance information.
	[JUMP]	Moves the cursor to the beginning or end.
	Cursor keys	Moves the cursor position up or down.
	Page keys	Scrolls the screen up or down in units of whole screens.
	Alphanumeric/ special character keys	Allows alphabetical, numeric, or special character input. (For details of half-size kana input, see Item, " Half-size kana input".)
	 key	Switches between insert and overwrite modes.
	 key	<ul style="list-style-type: none"> <li>• If the key input buffer does not contain any character, deletes the one character at the cursor position.</li> <li>• If the key input buffer contains characters, deletes the characters from the buffer.</li> </ul>
	 key	<ul style="list-style-type: none"> <li>• If the key input buffer does not contain any character, deletes the one character before the cursor.</li> <li>• If the key input buffer contains characters, deletes the one character from the buffer.</li> </ul>
	 key	<ul style="list-style-type: none"> <li>• If the key input buffer does not contain any character, starts a new line.</li> <li>• If the key input buffer contains characters, outputs the characters from the buffer to the information screen.</li> </ul>

### 1.10.3 Half-Size Kana Input on the Maintenance Information Screen

By pressing soft key [KN/ABC], you can switch between half-size kana input and alphabetic input modes.

In half-size kana input mode, alphabetic characters are converted in accordance with the "half-size kana/Roman character conversion table" and resultant half-size kana characters are displayed in the key input buffer.

Pressing the  key causes the characters in the key input buffer to be output to maintenance information.

Pressing the  key causes the characters to be deleted from the key input buffer and the one character of the maintenance information on which the cursor is positioned to be deleted.

Pressing the  key causes cancels conversion, and deletes one character from the key input buffer. If the key input buffer does not contain any character, the one character of the maintenance information that immediately precedes the cursor is deleted.

## 1.10.4 Warnings That Occurs on the Maintenance Information Screen

The following warnings occur on the maintenance information screen.

Warning message	Meaning
NO MORE SPACE	An overflow occurred in CNC memory.
ALARM	The operation could not be performed because an alarm was generated in the CNC.
BUSY	Wait for CNC processing to end or make a retry.
ILLEGAL DATA	Investigate data and correct it as required.
WRONG MODE	The CNC is in wrong mode.
COMMAND ILLEGAL USE	A corresponding CNC option cannot be found.
PARAMETER ERROR	CNC parameter settings contain an error.
EDIT REJECTED	An attempt was made to perform an edit operation on data that could not be edited.
WRITE PROTECT	Writing is prohibited.
COMMAND REJECT	The CNC rejected the execution of the processing. Check the execution conditions.

## 1.10.5 Parameter

	#7	#6	#5	#4	#3	#2	#1	#0
3116	MDC							

[Input type] Setting input

[Data type] Bit path

**#7 MDC** Maintenance information data:  
 0: Cannot be erased entirely.  
 1: Can be erased entirely.

	#7	#6	#5	#4	#3	#2	#1	#0
3206							MIF	

[Input type] Parameter input

[Data type] Bit

**#1 MIF** Editing of the maintenance information screen is:  
 0: Not prohibited.  
 1: Prohibited.

	#7	#6	#5	#4	#3	#2	#1	#0
8901	MEN							

[Input type] Setting input

[Data type] Bit path

**#7 MEN** The periodic maintenance screen is:  
 0: Displayed.  
 1: Not displayed.



## 1.10.6 Overview of the History Function

It is possible to record history of operations performed by the operator, alarms that occurred, external operator messages, etc. in order to check the history or output history data.

- 1 Conditions under which history is recorded
  - a Display screen  
History is recorded when a screen other than the operation history screen is displayed.
  - b Signal selection  
Up to 60 input/output signals for which history is recorded can be selected.
  - c Parameter setting  
It is possible to set parameters in order to specify individually whether to record data change history such as operation history of the MDI key, history of external operator messages, addition of external alarms/messages, parameters/tool offset, workpiece offset (workpiece shift amount)/custom macro common variable, operation history of input/output signals.
  - d Storage capacity  
When the storage capacity is exhausted, data is deleted in the chronological order, oldest first. A maximum of approximately 8000 history items can be recorded when, for example, only the operation history of the MDI key is stored.
- 2 Data output  
All the history data items stored can be output to an external input/output unit (see the section about outputting of all history data).
- 3 Deletion of history  
When bit 7 (EKE) of parameter No. 3195 is 1, soft key [ALL CLEAR] appears, which can be used to delete history data.

	#7	#6	#5	#4	#3	#2	#1	#0
3195	EKE							

[Data type] Bit

- #7 EKE** The [ALL CLEAR] soft key for clearing all history data is:  
 0: Not displayed.  
 1: Displayed.

### NOTE

- 1 History data is not cleared even after power-off.  
If memory clear operation is performed, however, history data is also deleted.
- 2 The correct date and time need to be set on the setting screen.
- 3 All history data items including alarms, external operator messages, operations, and input/output signals are integrated into one and stored in a single storage area. Therefore, when the storage capacity is exhausted, data is deleted in the chronological order, oldest first, regardless of the type of history.  
The deletion of history data deletes all history data, so care should be executed before performing deletion.  
Delete operation cannot be performed on a per-history-type basis.

### 1.10.6.1 Alarm history

Only alarm history is extracted from all history data recorded and displayed on the screen. When the amount of history data exceeds the storage capacity, data is automatically deleted in the chronological order, oldest first.



Fig. 1.10.6.1 (a) Alarm history screen

### Screen display

The alarms that occurred are displayed in the chronological order, most recent first.

The following items are indicated for each alarm.

- Path name (only for multi-path operation)
- Date and time of alarm issuance
- Alarm type and number
- Alarm message





#### NOTE

To record external alarm and macro alarm messages as history data, set bit 3 (EAH) of parameter No. 3112 to 1 and bit 7 (HAL) of parameter No. 3196 to 0.

If the path name, axis name, or spindle name is changed after occurrence of an alarm, the new name is displayed on the alarm history screen.

For modal 'O' data, only the first five characters are output in the case of the program name.

#### - Procedure

- 1 Press function key  to display the screen for parameters etc.
- 2 Press return menu key .
- 3 Press the continuous menu key  several times until soft key [HISTORY] is displayed.
- 4 Press soft key [HISTORY] to display the alarm history screen.
- 5 Press page switching keys   to move between the previous page and the next page.

## Deleting history data on the alarm history screen

### - Procedure

- 1 Display the alarm history screen.
- 2 Press the soft key [(OPRT)].
- 3 If soft key [(CLEAR)] is pressed, all history data is deleted.

### NOTE

The delete operation deletes not only alarm history, but also external operator message history, operation history, and other history data. Delete operation cannot be performed on a per-history-type basis.

## Holding alarm history

Alarm history is held in the same storage area as in other history data such as key operation history and signal change history. Therefore, alarm history is deleted when the storage capacity is fully exhausted by other history data.

When bit 2 (SAH) of parameter No. 11354 is set to 1, alarm history data is stored in the area specific to alarm history and recorded in the storage area for operation history. Accordingly, up to 50 alarm history items can be held even if the storage capacity is fully exhausted by other history data.

However, additional information (modal data, absolute coordinates, and machine coordinates during occurrence of an alarm) is not recorded in the area specific to alarm history. (The additional information is recorded in the storage area of operation history.)

## Deleting alarm history

If history is deleted on the alarm history screen when bit 2 (SAH) of parameter No. 11354 is set to 1, only the alarm history is deleted. Even if history is deleted on the operation history screen or external operator message screen, alarm history is not deleted.

## Parameter setting

	#7	#6	#5	#4	#3	#2	#1	#0
11354						SAH		

[Data type] Bit

- #2 SAH** When the storage capacity for history data is exceeded due to non-alarm history, alarm history will be:
- 0: Erased.
  - 1: Erased, except the most recent 50 items of history data.

## Displaying an external alarm or macro alarm

When an external alarm or macro alarm is caused by setting the following parameters, the message in addition to the alarm number can be recorded in alarm history.

	#7	#6	#5	#4	#3	#2	#1	#0
3112					EAH			

[Data type] Bit

- #3 EAH** Messages of the external alarm/macro alarm in alarm or operation history:
- 0: Not recorded
  - 1: Recorded

**NOTE**  
 This parameter is valid when bit 7 (HAL) of parameter No. 3196 is set to 0.

	#7	#6	#5	#4	#3	#2	#1	#0
3196	HAL							

[Input type] Parameter input  
 [Data type] Bit

- #7 **HAL** When an alarm is issued, additional information (modal data, absolute coordinates, and machine coordinates present at the issuance of the alarm) is:  
 0: Recorded in the operation history and alarm history.  
 1: Not recorded in the operation history and alarm history.

**NOTE**

- 1 Since alarms, operations, external operator messages, and data change history are held in the same storage area, alarm history may be deleted if the storage capacity is fully exhausted by other history data.
- 2 The maximum number of history items that can be recorded is shown below (when the history items are alarms).  
 When bit 7 (HAL) of parameter No. 3196 is 1, the maximum number is approximately 4000.  
 When bit 7 (HAL) of parameter No. 3196 is 0, the maximum number depends on the system because the modal information and coordinates during occurrence of an alarm are also recorded. (Example: 280 for 5-axis systems and 200 for 10-axis systems)  
 When bit 3 (EAH) of parameter No. 3112 is 1, however, messages for macro alarms and external alarms are also recorded, the maximum number is further reduced.

### 1.10.6.2 External operator message history

Only external operator message history and macro message history are extracted from all history data recorded and displayed on the screen. When the amount of history data exceeds the storage capacity, data is automatically deleted in the chronological order, oldest first.



When bit 3 (SOH) of parameter No. 11354 is set to 1, external operator message history data is stored in the area specific to external operator message history and recorded in the storage area for operation history. Accordingly, external operator message history items can be held even if the storage capacity is fully exhausted by other history data.

**Deleting external operator message history**

If history is deleted on the external operator message history screen when bit 3 (SOH) of parameter No. 11354 is set to 1, only the external operator message history is deleted. Even if history is deleted on the operation history screen or alarm history screen, external operator message history is not deleted.

**Number of characters in external operator message history and number of external operator messages**

When bit 3 (SOH) of parameter No. 11354 is set to 1, the number of characters in external operator message history and the number of external operator messages are set by bit 6 (MS0) and bit 7 (MS1) of parameter No. 3113. The correspondence between the settings, the number of characters, and the number of messages is shown in Table 1.10.6.2 (a).

Table 1.10.6.2 (a)

Parameter		Maximum number of characters	Number of messages
MS0=0	MS1=0	255	8
MS0=1	MS1=0	200	10
MS0=0	MS1=1	100	18
MS0=1	MS1=1	50	32

**Parameter setting**

	#7	#6	#5	#4	#3	#2	#1	#0
3112						OMH		

[Input type] Parameter input  
 [Data type] Bit

#2 **OMH** The external operator message history screen is:  
 0: Not displayed.  
 1: Displayed.

	#7	#6	#5	#4	#3	#2	#1	#0
3113	MS1	MS0						HMC

[Input type] Parameter input  
 [Data type] Bit

#0 **HMC** The contents of the external operator message history:  
 0: Cannot be erased.  
 1: Can be erased.

**NOTE**  
 This parameter is valid when bit 3 (SOH) of parameter No. 11354 is set to 1.

#6 **MS0**  
 #7 **MS1** Set the combination of the number of characters and the number of messages to be preserved in the external operator message history.

Table 1.10.6.2 (b)

Parameter		Maximum number of characters	Number of messages
MS0=0	MS1=0	255	8
MS0=1	MS1=0	200	10
MS0=0	MS1=1	100	18
MS0=1	MS1=1	50	32

**NOTE**

- 1 Although up to 255 characters can be specified for each external operator message, you can use the combination of bits 6 (MS0) and 7 (MS1) of parameter No. 3113 to limit the number of characters and select the number of messages to be preserved in the external operator message history.
- 2 The settings of bits 6 (MS0) and 7 (MS1) of parameter No. 3113 take effect the next time the power is turned on. The external operator message history is erased at that time.
- 3 Even though you change the settings of bits 6 (MS0) and 7 (MS1) of parameter No. 3113, the alarm PW0000, "POWER MUST BE OFF" is not issued. You must however turn on the power again before the new settings can take effect.
- 4 If text (such as single-byte katakana or kanji characters) is entered in character code, the number of characters recorded in the external operator message history may be smaller than the maximum number of characters set by bits 6 (MS0) and 7 (MS1) of parameter No. 3113.

	#7	#6	#5	#4	#3	#2	#1	#0
3196		HOM						

[Input type] Parameter input

[Data type] Bit

**#6 HOM** A history of external operator messages and macro messages ((#3006) is:

0: Recorded.

1: Not recorded.

	#7	#6	#5	#4	#3	#2	#1	#0
11354					SOH			

[Input type] Parameter input

[Data type] Bit

**#3 SOH** When the storage capacity for history data is exceeded due to data other than external operator message history, external operator message history will be:

0: Erased.

1: Retained.

**NOTE**

- 1 The setting of bit 3 (SOH) of parameter No. 11354 will be effective the next time the power is turned on. At this time, all history data (operation history, alarm history, and external operator message history) will be erased.

**NOTE**  
 2 When bit 3 (SOH) of parameter No. 11354 is set to 1, the number of history data items that can be retained varies. The number of history data items that can be recorded as follows:  
     Bit 3 (SOH) of parameter No. 11354=0 . . . Approx. 8000 items  
     Bit 3 (SOH) of parameter No. 11354=1 . . . Approx. 7500 items  
 (\*) The numbers of items above are those if only key operation history is recorded.

### 1.10.6.3 Operation history

This function displays the history of key-in and signal operation performed by the operator when a failure or alarm occurs and the history of an alarm that occurred.

What is recorded is shown below.

- a Operation history
  - i MDI key operation by the operator
  - ii Turning on or off of output signals (X, Y, G, F)
- b Alarm history
  - i Alarm that occurred
  - ii Modal information and coordinates of the block executed during occurrence of an alarm (Not displayed on the screen.)
- c Data change history
  - i Change of tool offset data  
(When the bit 0 (HTO) of parameter No. 3196 is set to 1)
  - ii Change of workpiece offset data/extended workpiece offset data/workpiece shift amount (T series)  
(When the bit 1 (HWO) of parameter No. 3196 is set to 1)
  - iii Change of a parameter  
(When the bit 2 (HPM) of parameter No. 3196 is set to 1)
  - iv Change of custom macro common variable data  
(When the bit 3 (HMOV) of parameter No. 3196 is set to 1)
- d External operator message history and macro message history  
(When the bit 6 (HOM) of parameter No. 3196 is set to 0)
- e Time stamp (date/time)

History data of operation history and alarm history except certain parts can be referenced on the operation history screen. (Data change history, external operator message history, and alarm messages are not displayed.)

All of recorded history data can be output to external input/output units.

**NOTE**  
 The maximum number of items that can be recorded is approximately 8000 when the items are assumed to be MDI key operation history. Since each history data size is not constant, however, the maximum number varies.

### Parameter setting

	#7	#6	#5	#4	#3	#2	#1	#0
3106				OPH				

- #4 OPH** The operation history screen is:  
 0: Not displayed.  
 1: Displayed.



3122	Time interval used to record time data in operation history
------	---

[Input type] Parameter input  
 [Data type] Word  
 [Unit of data] min  
 [Valid data range] 0 to 1440  
 Time data is recorded in operation history at specified time intervals.  
 When 0 is set, the specification of a time period of 10 minutes is assumed.  
 If data to be recorded is not present within the time period, no time data is recorded.

**NOTE**  
 This parameter must be set to the same value for all paths.

	#7	#6	#5	#4	#3	#2	#1	#0
3195	EKE	HDE	HKE					

[Input type] Parameter input  
 [Data type] Bit

**#5 HKE** A key operation history is:  
 0: Recorded.  
 1: Not recorded.

**#6 HDE** A DI/DO history is:  
 0: Recorded.  
 1: Not recorded.

**#7 EKE** The [ALL CLEAR] soft key for clearing all history data is:  
 0: Not displayed.  
 1: Displayed.

	#7	#6	#5	#4	#3	#2	#1	#0
3196	HAL	HOM			HMV	HPM	HWO	HTO

[Input type] Parameter input  
 [Data type] Bit

**#0 HTO** A modification history of tool offset data is:  
 0: Not recorded.  
 1: Recorded.

**#1 HWO** A modification history of workpiece offset data/extended workpiece offset data/workpiece shift (T series) is:  
 0: Not recorded.  
 1: Recorded.

**#2 HPM** A modification history of parameters is:  
 0: Not recorded.  
 1: Recorded.

**#3 HMV** A modification history of custom macro common variables is:  
 0: Not recorded.  
 1: Recorded.

#6 **HOM** A history of external operator messages and macro messages ((#3006) is:

- 0: Recorded.
- 1: Not recorded.

#7 **HAL** When an alarm is issued, additional information (modal data, absolute coordinates, and machine coordinates present at the issuance of the alarm) is:

- 0: Recorded in the operation history and alarm history.
- 1: Not recorded in the operation history and alarm history.

To record as many alarm history items as possible, rather than detailed alarm information, set 1. In addition, 10 G code modal group numbers that need to be recorded are set in parameters Nos. 12990 to 12999.

12990	<b>G code modal group (first one) to be recorded as history data when an alarm is issued</b>
to	to
12999	<b>G code modal group (tenth one) to be recorded as history data when an alarm is issued</b>

[Input type] Parameter input

[Data type] Byte path





[Valid data range] 1 to maximum G code group number



Set a G code modal group number to be recorded as alarm history and operation history data when an alarm is issued.

\* If a specified value falls outside the data range, the states of groups 01 to 10 are recorded.

## Screen display

### - Procedure

- 1 Press function key .
- 2 Press the continuous menu key  several times until soft key [OPERAT HISTRY] is displayed.
- 3 Press soft key [OPERAT HISTRY] and then press soft key [OPERAT HISTRY] that newly appears to display the operation history screen.
- 4 To display subsequent operation history, press page switching keys   to move between the previous page and the next page.

To display the portion between pages, press one of cursor keys   to shift the display by half page.

(For the 8.4-inch display unit, however, the display shifts by one column.)

When soft key [(OPRT)] is pressed on the operation history screen, the following soft key operations can be performed.

- a Pressing [TOP] displays the first page, which contains the oldest data.
- b Pressing [BOTTOM] displays the last page, which contains the latest data.
- c Pressing [NO.SRH] displays specified operation history data.  
(Example) Entering 50 and pressing [NO.SRH] display 50th data.

OPERATION HISTORY				00123 N00000	
				No. 0001 / 0064	
No. DATA	No. DATA	No. DATA	No. DATA	No. DATA	No. DATA
1 2007/09/01 10:08:14	16 2007/09/01 10:08:36	28 2007/09/01 10:09:57	40 <PROG>	41 <MESSAGE>	
2 <CANCEL>	17 2007/09/01 10:09:04	29 F	30 0x00	42 <SYSTEM>	
3 <CANCEL>	18 SW0100 2007/09/01 10:09:10	31 SW0100 2007/09/01 10:10:35	32 <SYSTEM>	43 [RIGHT F]	
4 <CANCEL>	19 T	33 <PAGE ↓>	34 <PAGE ↓>	44 [RIGHT F]	
5 <CANCEL>	20 <SHIFT>	35 <CUR →>	36 <CUR →>	45 [RIGHT F]	
6 <CANCEL>	21 E	37 0	38 <INPUT>	46 [SOFT 9]	
7 <CANCEL>	22 S	39 <POS>	47 0	48 <INPUT>	
8 <CANCEL>	23 T		49 2007/09/01 10:20:00	50 <SYSTEM>	
9 <CANCEL>	24 [LEFT F]			51 [RIGHT F]	
10 <CANCEL>	25 [RIGHT F]			52 [RIGHT F]	
11 <CANCEL>	26 [SOFT 6]			53 [RIGHT F]	
12 <CANCEL>	27 2007/09/01			54 [SOFT 9]	
13 <CANCEL>					
14 <CANCEL>					
15 <RESET>					

A >

MEM **** * * *	12:00:00	PATH1
OPERAT HISTRY	SIGNAL SELECT	<OPRT>

Fig. 1.10.6.3 (a) Operation history screen

## Displayed information

- 1 Serial number and display start history number/total number of history items  
 A serial number is indicated to the left of each of recorded history data items. The smaller the serial number, the older the data item.  
 The display start history number/total number of history items is displayed at the upper right of the screen. The number of history data items that is not displayed on the screen is not included in the total number of history items.
- 2 Data
  - MDI key  
 When bit 5 (HKE) of parameter No. 3195 is 0, key operations are recorded.  
 A key operation is preceded by a path number as follows: 1\_[LEFT F] or 2\_[LEFT F]. (When the number of paths is 1, no path number is displayed.)  
 P\_ of P\_[LEFT F] indicates an external key operation.
    - i Address keys, numerical keys  
 Characters such as A to Z, 0 to 9, ";", "+", and "-" are directly displayed with black text.
    - ii Function menu keys, operation menu keys, soft keys  
 A key name is enclosed by square brackets as follows and displayed with green text: [LEFT F], [SOFT 1] to [SOFT 10], [RIGHT F].
    - iii Function keys, page keys, cursor keys, etc.  
 A key name is enclosed by angle brackets as follows and displayed with green text: <POS>, <SYSTEM>, <PAGE ↑>, <CUR →>, <RESET>, <INPUT>, etc.
    - iv Key at power-on  
 A key name is displayed with white text against a green background.

- Input/output signals  
When bit 6 (HDE) of parameter No. 3195 is 0, the input/output signal specified on the operation history signal selection screen is recorded. The address of the signal and a change in each bit are displayed. This display is performed with purple text.

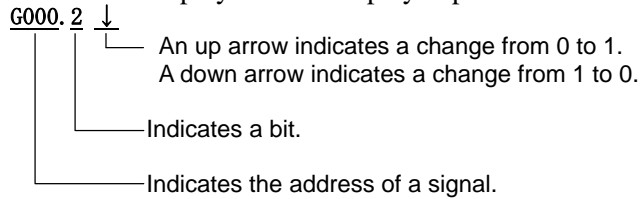

**NOTE**

- 1 When multiple bits at the same address change at the same timing, the change is handled as one history data item.
- 2 A change in a signal less than 4 msec is not recorded as history data.

- Alarm  
The number of an alarm and the time when the alarm occurred are displayed on the operation history screen.  
The display is performed with white text against a red background.

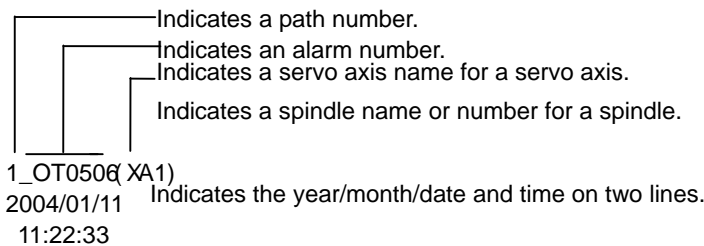

If a path name, axis name, or spindle name is changed after occurrence of an alarm, the new name is displayed.

- Date/time  
The data and time of the following items are displayed on two lines.
  - i The date and time of power-on are displayed with white text against a green background.
  - ii The date and time of power-off are displayed with green text.
  - iii The date when the date changes is displayed with black text.
  - iv The dates and times at certain time intervals set in parameter No. 3122 are displayed with black text.
  - v The date and time when history data was deleted is displayed with black text.

**NOTE**

- 1 In storing time data at certain time intervals, if data to be stored is not present within a certain time period, the time data is not stored. (If time data is stored because the date changes, data to be stored is assumed to be present.)
- 2 If the date and time of a CNC system is changed, the new date and time may be recorded as the date and time in iii or iv.

**History data not displayed on the screen**

In addition to history data such as the MDI key, input/output signal state, alarm that occurred, external operator message (not displayed on the operation history screen), and time stamp, the following data can be displayed together with time data. These history data items cannot be displayed on the screen, but can be output to external input/output units (see the section about outputting of all history data).

- 1 Detailed data during occurrence of an alarm  
When bit 7 (HAL) of parameter No. 3196 is 0, 10 G code modals of the block that was being executed during occurrence of an alarm, the second auxiliary function codes D, E, F, H, M, N, O, S, and T, absolute values, and machine coordinates are recorded together with the alarm number and the time of occurrence.  
The group numbers of 10 G code modals to be recorded are set in parameters Nos. 12990 to 12999. If they are not set, the G code modals of groups 01 to 10 are recorded.

**NOTE**

For modal 'O' data, only the first five characters are recorded in the case of the program name.  
To increase the number as compared with detailed data on occurrence of an alarm, set bit 7 (HAL) of parameter No. 3196 to 1.

- 2 External alarm message and macro alarm message  
When bit 3 (EAH) of parameter No. 3112 is 1, external alarm messages and macro alarm messages can be recorded as history data. However, only the first 64 characters are recorded.

**NOTE**

To record external alarm messages and macro alarm messages as history data, set bit 3 (EAH) of parameter No. 3112 to 1 and bit 7 (HAL) of parameter No. 3196 to 0.

- 3 Changing the tool offset data  
When bit 0 (HTO) of parameter No. 3196 is 1, changing the tool offset data records the changed offset number and type, the changed tool offset data, the new tool offset data, and the change time.
- 4 Changing the workpiece offset, extended workpiece offset, or workpiece shift (T series) data  
When bit 1 (HWO) of parameter No. 3196 is 1, changing the workpiece offset data records the changed offset number, the changed workpiece offset data, the new workpiece offset data, and the change time. These items are also recorded when the extended workpiece offset or workpiece shift amount (for the T series) is changed.
- 5 Changing a parameter  
When bit 2 (HPM) of parameter No. 3196 is 1, changing a parameter records the changed parameter number, type (axis type, spindle type, path type, and machine group type), the changed parameter data, the new parameter data, and the change time.

**NOTE**

History concerning changes during power-on and changes of the password and keys is not recorded.

- 6 Changing custom macro common variables (#100 to #999)  
When bit 3 (HMV) of parameter No. 3196 is 1, changing a custom macro common variable records the changed common variable number, the changed common variable value, the new common variable value, and the change time.

---

## Deleting history data on the operation history screen

### - Procedure

- 1 Display the operation history screen.
- 2 Press the soft key [(OPRT)].

- 3 Press the soft key [ALL CLEAR].
- 4 If soft key [EXEC] is pressed, all history data is deleted.





**NOTE**

The delete operation deletes not only operation history, but also external operator message history, alarm history, and other history data. Delete operation cannot be performed on a per-history-type basis.

### 1.10.6.4 Operation history signal selection



An input/output signal for recording history can be selected. A maximum of 60 signals can be set.

#### Setting data

- 1 Press function key .
- 2 Press the continuous menu key  several times until soft key [OPERAT HISTRY] is displayed.
- 3 Press soft key [OPERAT HISTRY].
- 4 Press soft key [SIGNAL SELECT] to display the operation history signal selection screen.
- 5 Press soft key [(OPRT)].
- 6 Press cursor movement keys   to move the cursor to a desired position.
- 7 Operate keys to enter the signal type (X, G, F, or Y) followed by the address and press .

Example) Entering G0004 and pressing .

Then entered signal address "G0004" appears in the ADDRESS position and the initial value "00000000" is set in the SIGNAL position.

- 8 Select the bit to be recorded as history.  
To change all bits of a specified signal address, move the cursor so that all bits are displayed in reverse video as "00000000" and then press soft key [ON:1] or [OFF:0] to change the bits to "11111111" or "00000000".  
To change only a particular bit, move the cursor with cursor movement keys   to the bit to be changed and then press soft key [ON:1] or [OFF:0] to change the bits to 1 or 0.
- 9 A maximum of 60 signals can be selected. It is not necessary to set signals contiguously from No. 1.

**NOTE**

- 1 When the operation history signal selection screen is displayed, no history is recorded.
- 2 The addresses that can be set for an input/output signal are X, Y, G, and F only. When no data is set, \*\*\*\*\* appears.
- 3 If all bits are 0 even when an address is set, no history is recorded.
- 4 When the ON/OFF width of an input signal is 4 msec or less, nothing is recorded in history data. Some signals are not recorded.
- 5 When the number of selected signals is large, the processing speed may be reduced.

#### Clearing individual data items

- 1 Display the operation history signal selection screen.
- 2 Move the cursor to the data to be cleared.
- 3 Press soft key [DELETE].
- 4 Press soft key [EXEC].

### Clearing all data items

- 1 Display the operation history signal selection screen.
- 2 Press soft key [ALLDEL].
- 3 Press soft key [EXEC].

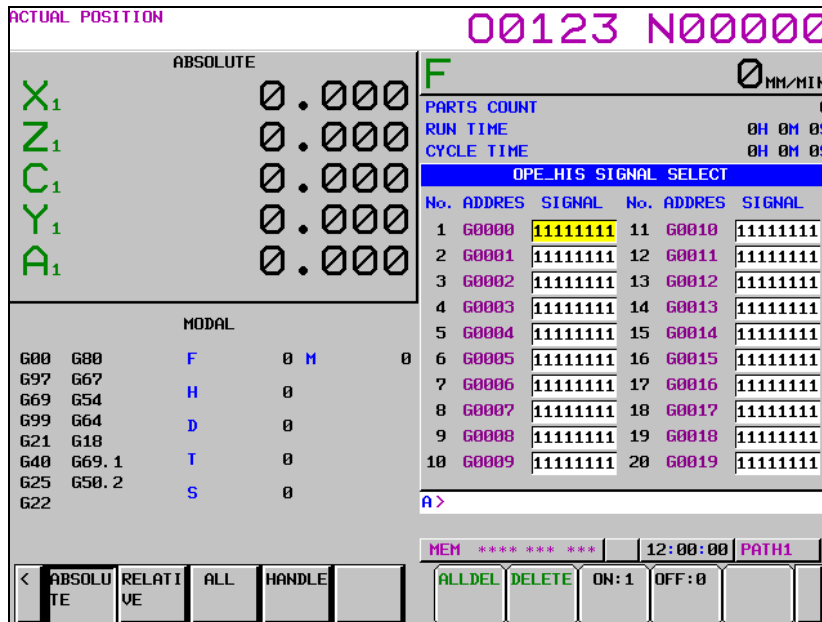

Fig. 1.10.6.4 (a) Operation history signal selection screen

### Selection by the parameter

When bit 4 (PHS) of parameter No. 3206 is 1, an input/output signal for which history is recorded can be set by the parameter.

When a signal is selected or deselected on the operation history signal selection screen in this case, the value of the corresponding parameter automatically changes. When the value of the parameter is changed on the parameter screen, the display of the operation history signal selection screen changes.

This is the same as in input operations. When operation history signal selection data is input on the operation history signal selection screen, the value of the corresponding parameter automatically changes. When the value of parameter is input on the parameter screen, the display of the operation history signal selection screen changes.

The first 20 data items of the 60 data items can be set by the parameter.

### Parameter setting

	#7	#6	#5	#4	#3	#2	#1	#0
3206				PHS				

[Input type] Parameter input

[Data type] Bit

#### #4 PHS Operation history signal selection:

0: Does not interact with parameters.

Operation history signal selection is added or deleted on the operation history signal selection screen.

Changing the settings of parameters Nos. 24901 to 24920, Nos. 12801 to 12820, Nos. 12841 to 12860, or Nos. 12881 to 12900 has no effect on operation history signal selection.

Changes to the signals of the addresses specified by parameters Nos. 24901 to 24920, Nos. 12801 to 12820, Nos. 12841 to 12860, or Nos. 12881 to 12900 are not recorded in the history.

- 1: Interacts with parameters.  
Operation history signal selection can be performed either on the operation history signal selection screen or by setting parameters.

**NOTE**  
Setting this parameter to 1 reflects the current operation history signal selection data on parameters Nos. 24901 to 24920 and Nos. 12801 to 12900.

24901	Operation history signal selection PMC path number (No. 01)	
to	to	
24920	Operation history signal selection PMC path number (No. 20)	

- [Input type] Parameter input
- [Data type] Byte
- [Valid data range] 0 to 3

These parameters set operation history signal selection PMC path numbers Nos. 1 to 20. The correspondence between PMC path numbers and settings is as given in the Table 1.10.6.4 (a).

**Table 1.10.6.4 (a)**

PMC path number	Parameter value
Not selected.	0
1st PMC	1
2nd PMC	2
3rd PMC	3

These parameters are paired with other parameters as given below (Table 1.10.6.4 (b)).

**Table 1.10.6.4 (b)**

No.	PMC path number	Address type	Address number	Bit number
01	No. 24901	No. 12801	No. 12841	No. 12881
02	No. 24902	No. 12802	No. 12842	No. 12882
03	No. 24903	No. 12803	No. 12843	No. 12883
...		...	...	...
20	No. 24920	No. 12820	No. 12860	No. 12900

**NOTE**

- 1 Operation history signals that can be selected and deselected with parameters are for the first 20 of 60 sets. If an operation history signal is specified from the operation history signal selection screen, the PMC path number is fixed at the first PMC.
- 2 To deselect a signal, set 0.  
At this time, 0 is set as the initial value in the address type (Nos. 12801 to 12820), the address number (Nos. 12841 to 12860), and the bit number (Nos. 12881 to 12900) corresponding to that signal.



**NOTE**

3 When a PMC path number is set, 1 is set as the initial value in the address type (Nos. 12801 to 12820) corresponding to that signal, and 0 is set as the initial value in the address number (Nos. 12841 to 12860) and the bit number (Nos. 12881 to 12900).  
 [Example]  
 If parameter No. 24901 is set to 1, the parameters are initialized as follows:  
 No. 12801=1                      Address type  
 No. 12841=0                      Address number  
 No. 12881=00000000          Bit number  
 If, however, the address type (Nos. 12801 to 12820) corresponding to that signal is set, the address type (Nos. 12801 to 12820), the address number (Nos. 12841 to 12860), and the bit number (Nos. 12881 to 12900) will not be initialized.

4 If an attempt is made to set a value that cannot be set, a warning, "DATA IS OUT OF RANGE" appears; retry setting a value.

12801	Operation history signal selection address type (No. 01)
to	to
12820	Operation history signal selection address type (No. 20)

[Input type] Parameter input  
 [Data type] Byte  
 [Valid data range] 0 to 4

These parameters set operation history signal selection address types Nos. 1 to 20. The correspondence between address types and settings is as given in the Table 1.10.6.4 (c).

**Table 1.10.6.4 (c)**

Address type	Parameter value
Not selected.	0
X	1
G	2
Y	3
F	4

These parameters are paired with other parameters as given below (Table 1.10.6.4 (d)).

**Table 1.10.6.4 (d)**

No.	PMC path number	Address type	Address number	Bit number
01	No. 24901	No. 12801	No. 12841	No. 12881
02	No. 24902	No. 12802	No. 12842	No. 12882
03	No. 24903	No. 12803	No. 12843	No. 12883
...	...	...	...	...
20	No. 24920	No. 12820	No. 12860	No. 12900

**NOTE**

1 Operation history signals that can be selected and deselected with parameters are for the first 20 of 60 sets. If an operation history signal is specified from the operation history signal selection screen, the PMC path number is fixed at the first PMC.

**NOTE**

2 To deselect a signal, set 0.  
At this time, 0 is set as the initial value in the address number (Nos. 12841 to 12860) and the bit number (Nos. 12881 to 12900) corresponding to that signal.

3 When an address type is set, 1 is set as the initial value in the PMC path number (Nos. 24901 to 24920) corresponding to that signal, and 0 is set as the initial value in the address number (Nos. 12841 to 12860) and the bit number (Nos. 12881 to 12900).  
[Example]  
If parameter No. 12801 is set to 2, the parameters are initialized as follows:  
No. 24901=1                      PMC path number  
No. 12841=0                      Address number  
No. 12881=00000000          Bit number  
If, however, the PMC path number (Nos. 24901 to 24920) corresponding to that signal is set, the PMC path number (Nos. 24901 to 24920) will not be initialized.

4 If an attempt is made to set a value that cannot be set, a warning, "DATA IS OUT OF RANGE" appears; retry setting a value.

12841	to	Operation history signal selection address number (No. 01)
12860	to	Operation history signal selection address number (No. 20)

- [Input type] Parameter input
- [Data type] Word
- [Valid data range] For an explanation of the address ranges of the G, F, X, and Y signals, refer to the PMC Programming Manual (B-64513EN).

These parameters set operation history signal selection address numbers Nos. 1 to 20. These parameters are paired with other parameters as given below (Table 1.10.6.4 (e)).

**Table 1.10.6.4 (e)**

No.	PMC path number	Address type	Address number	Bit number
01	No. 24901	No. 12801	No. 12841	No. 12881
02	No. 24902	No. 12802	No. 12842	No. 12882
03	No. 24903	No. 12803	No. 12843	No. 12883
...		...	...	...
20	No. 24920	No. 12820	No. 12860	No. 12900

**NOTE**

1 Operation history signals that can be selected and deselected with parameters are for the first 20 of 60 sets.

2 When an address number is set, 0 is set as the initial value in the bit number (Nos. 12881 to 12900) corresponding to that signal.

3 If an attempt is made to set a value that cannot be set or if the address type (Nos. 12801 to 12820) corresponding to that signal is 0, a warning, "DATA IS OUT OF RANGE" appears; retry setting a value.

	#7	#6	#5	#4	#3	#2	#1	#0
12881	RB7	RB6	RB5	RB4	RB3	RB2	RB1	RB0
to	to							
12900	RB7	RB6	RB5	RB4	RB3	RB2	RB1	RB0

[Input type] Parameter input

[Data type] Bit

**RB7 - RB0** History of the respective operation history signal selection bits Nos. 1 to 20 (RB7 to RB0) corresponding to the operation history signal selection addresses set in parameters Nos. 12801 to 12860 is:

0 : Not retained. (History of the bit is not recorded.)

1 : Retained. (History of the bit is recorded.)

These parameters are paired with other parameters as given below (Table 1.10.6.4 (f)).

Table 1.10.6.4 (f)



No.	PMC path number	Address type	Address number	Bit number
01	No. 24901	No. 12801	No. 12841	No. 12881
02	No. 24902	No. 12802	No. 12842	No. 12882
03	No. 24903	No. 12803	No. 12843	No. 12883
...		...	...	...
20	No. 24920	No. 12820	No. 12860	No. 12900

### 1.10.6.5 Outputting all history data

All history data items can be output to an external input/output unit.

History data items cannot be output individually.

#### Procedure

- 1 Make sure the output device is ready for output.
- 2 Enter the EDIT mode.
- 3 Press function key .
- 4 Press the continuous menu key  several times until soft key [OPERAT HISTORY] is displayed.
- 5 Press soft key [OPERAT HISTORY] and then press soft key [OPERAT HISTORY] that newly appears to display the operation history screen.
- 6 Press soft key [(OPRT)].
- 7 Press soft key [PUNCH].
- 8 Enter the file name and press soft key [EXEC].  
When pressing soft key [EXEC] without entering a file name, the name of the output file name is "OPRT\_HIS.TXT".

#### Output format

History is output as an ASCII file in the following format.

- 1 MDI key  
"MDI" is followed by "path number\_", "key data", and "input time".  
(The key data that is input during power-on is indicated as "Power on MDI".)  
<Example>  
MDI 01\_A 12:23:34  
MDI 02\_<CAN> 12:23:34  
MDI 02\_[SOFT HF1] 12:23:35  
MDI P\_<RESET> 12:34:56  
Power on MDI 01\_<RESET> 12:34:56

## 2 Input/output signal

"DI/DO" is followed by "PMC number\_", "signal address bit state", and "change time".

<Example>

```
DI/DO 1_F0002.2_on 12:34:56
DI/DO 1_ G0043.0_off G0043.1_off 12:35:00
(Example of the same address and multiple bits)
```

## 3 Alarm

"Alarm" is followed by "path number\_", "type", "alarm number", "G code modal data", "non-G-code modal data", each axis "absolute coordinates", "machine coordinates", and "data and time of occurrence".

The modal data for which a command is present in the block that was being executed during occurrence of an alarm is preceded by "\*".

<Example>

- Alarm 01\_SR01973  
\*G0. G97. G69. G99. G21. G50.2 G25. G13.1 B0. D0. E0. \*F100. H0. M10. \*N123. Test\_ S1000. T1010.  
X1 ABS 197.999 MCN 197.999 Y1 ABS -199806.00 MCN -199806.00 Z1 ABS 297.009 MCN 0.123 C1 ABS 10395.999 MCN 0.000 at 2007/09/01 19:03:28
- Alarm 02\_OT00506(ZA2)  
\*G1. G17. G90. G22. G94. G20. \*G42. G49. G80. G12.1 B0. \*D12. E0. \*F100. H34. M0. \*N123. O123 S0. T0.  
X2 ABS 123.999 MCN 234.000 Y2 ABS -123.00 MCN -234.00 ZA2 ABS 1234.567 MCN -1234.567 at 2007/09/01 12:34:56
- When no additional information is recorded during occurrence of an alarm (bit 7 (HAL) of parameter No. 3196 is 1), only "path number\_", "alarm number", and "data and time of occurrence" are output.  
Alarm 01\_OT00506(XC1) at 2007/09/01 22:08:32  
Alarm 02\_SW00100 at 2007/09/01 19:07:52
- When external alarm messages and macro alarm messages are recorded (bit 7 (HAL) of parameter No. 3196 is 0 and bit 3 (EAH) of parameter No. 3112 is 1), the messages are also output.  
Alarm 01\_MC00001 Message ATC ALARM  
G0. G97. G69. G99. G21. G40. G25. G22. G80. D0. E0. F0. H0. M0. N0. O9999 S0. T0.  
X2 ABS 10.000 MCN 0.000 Y2 ABS 123.000 MCN 0.000 Z2 ABS 0.000 MCN 0.000 at 2007/09/01 10:06:43

## 4 External operator message

"EXT\_Message" is followed by "message number", "message", and "data and time of occurrence".

<Example>

```
EXT_Message 01234 OIL PRESSURE DECREASE at 2007/09/01 2:38:43
```

## 5 Changing the tool offset data

"Tool Offset" is followed by "path number", "type", "offset number", "changed offset data", "changing offset data", and "change time". The type is described below.

Common to M/T	: G = geometric compensation	W = wear compensation
M series	: H = tool length compensation	D = cutter compensation
T series	: R = tool-nose radius compensation	T = tool direction
	X2, Z2, Y2 = second geometric compensation	

<Example>

```
Tool Offset 01_X0002 0.000 → 1 at 12:15:43
Tool Offset 02_XW0001 -9999.999 → 9999.999 at 12:15:46
Tool Offset 01_RG0032 0.000 → 0.003 at 12:15:52
Tool Offset 02_T0001 5. → 2. at 19:34:11
```

Tool Offset 02\_W0123 -10.000 → 123.456 at 10:28:58  
 Tool Offset 01\_HG0456 0.000 → 999.999 at 11:37:40  
 Tool Offset 01\_ 0064 12.340 → 12.569 at 11:39:42

- 6 Changing the workpiece offset/extended workpiece offset/workpiece shift (T series) data  
 "Work Offset/EXT Work Offset/Work Shift" is followed by "path number\_(axis name)", "type", "offset number", "changed offset data", "changing offset data", and "change time".

<Example>

Work Offset 01\_G55(XA1) 15.000 → 0.007 at 09:23:03  
 Work Offset 02\_EXT(Z2) 0.000 → 300.003 at 09:22:50  
 EXT Work Offset 02\_G54.1P300 (Y2) 123.456 → 9999.999 at 12:15:46  
 Work Shift (X) 02\_999999.999 → 999999.999 at 10:22:37

- 7 Changing a parameter  
 "Parameter" is followed by "type", "parameter number", "changed parameter", "changing parameter", and "change time".

The type is described below.

Path type: A path number is preceded by L.  
 Axis type: An axis number is preceded by A.  
 Spindle type: A spindle number of preceded by S.  
 Machine group type: A machine group is preceded by T.  
 Others: No type is output.

<Example>

Parameter N03112 00000100 → 00001100 at 11:18:40  
 Parameter Path type N01410 L02 0.000 → 1000.000 at 18:58:48  
 Parameter Axis type N01423 A04(B2) 0.000 → 10000.000 at 18:58:48  
 Parameter Spindle type N04011 S1(S) 10011010 → 10011010 at 18:58:53  
 Parameter Machine type N06310 T01 0 → -32768 at 19:21:13

- 8 Changing custom macro common variables (#100 to #999)  
 "Macro variable" is followed by "path number", "#variable name", "changed common variable", "changing common variable", and "change time".

Variables are output in the data form of  $M \times (10^{**}(-E))$ .

<Example>

- When #149 of the first path is changed from empty to 12.345  
 Macro variable 01\_#149 Empty → 123450000\*(10\*\*(-7)) at 15:02:35
- When #549 of the second path is changed from -12.345 to 123456789012  
 Macro variable 02\_#549 -123450000\*(10\*\*(-7)) → 123456789\*(10\*\*3) at 15:03:27



- 9 Data/time
- |                                    |                                      |
|------------------------------------|--------------------------------------|
| Power on at 2007/09/01 17:11:17    | (Data/time of power-on)              |
| Power off at 2007/09/01 17:49:17   | (Data/time of power-off)             |
| Date 2007/09/01 00:00:00           | (Record of date change)              |
| Time stamp at 2007/09/01 15:51:00  | (Record at certain time intervals)   |
| Data delete at 2007/09/01 10:56:18 | (Data/time of history data deletion) |





The following information is displayed.

- (1) Date and time of system alarm issuance
- (2) System alarm number
- (3) System alarm message

## Procedure

- 1 Press function key .
- 2 Press the continuous menu key  several times until soft key [SYSALM HIS.] is displayed.
- 3 Press soft key [SYSALM HIS.].
- 4 The system alarm history list screen as shown in Fig. 1.11 (b) appears.

### 1.11.2 System Alarm History Detail Screen

This screen displays details on system alarms. Page switching keys  ,  can be used to switch between pages to be displayed.

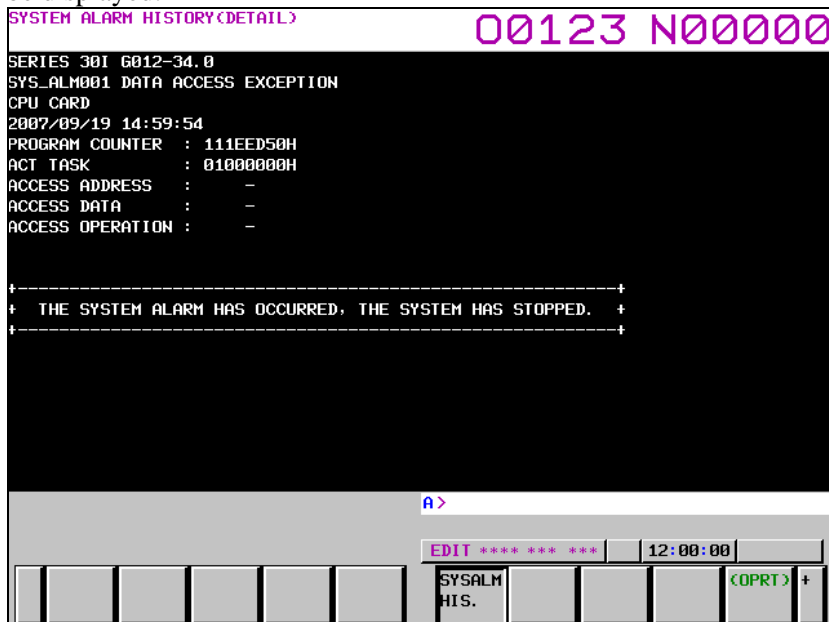



Fig. 1.11 (c) System alarm history detail screen

## Procedure

- 1 On the system alarm history list screen, move the cursor with  and  to the system alarm history for which detailed information is to be displayed.
- 2 Press [INPUT] key or soft key [(OPRT)] and then press soft key [SELECT].
- 3 Details of the selected system alarm history are displayed.

To move from the system alarm history detail screen to the list screen, follow the steps below.

- 1 On the system alarm history detail screen, press soft key [(OPRT)] and then press [RETURN].
- 2 The system alarm history list screen appears.

### 1.11.3 Outputting System Alarm History

This section describes the procedure for outputting system alarm history to an external unit.

#### Procedure

- 1 On the system alarm history detail screen, press soft key [(OPRT)] and press soft key [F OUTPUT].
- 2 Enter the name of a file to which history is output. If no file name is specified, the default file name (SYS-ALM.TXT) is assumed.
- 3 Press soft key [EXEC].

### 1.11.4 Parameter

	#7	#6	#5	#4	#3	#2	#1	#0
3103						NMH		

[Input type] Parameter input

[Data type] Bit

#2 **NMH** System alarm history screen is:

0: Not displayed.

1: Displayed.



## 2 CONTROL UNIT HARDWARE

This chapter describes the hardware configuration of the control unit, various printed-circuit boards in the control unit, their locations, LED indicators, and their locations.

### 2.1 EXAMPLE OF HARDWARE CONFIGURATION

#### 2.1.1 Example of the Hardware Configuration of the LCD-mounted Type Control Unit

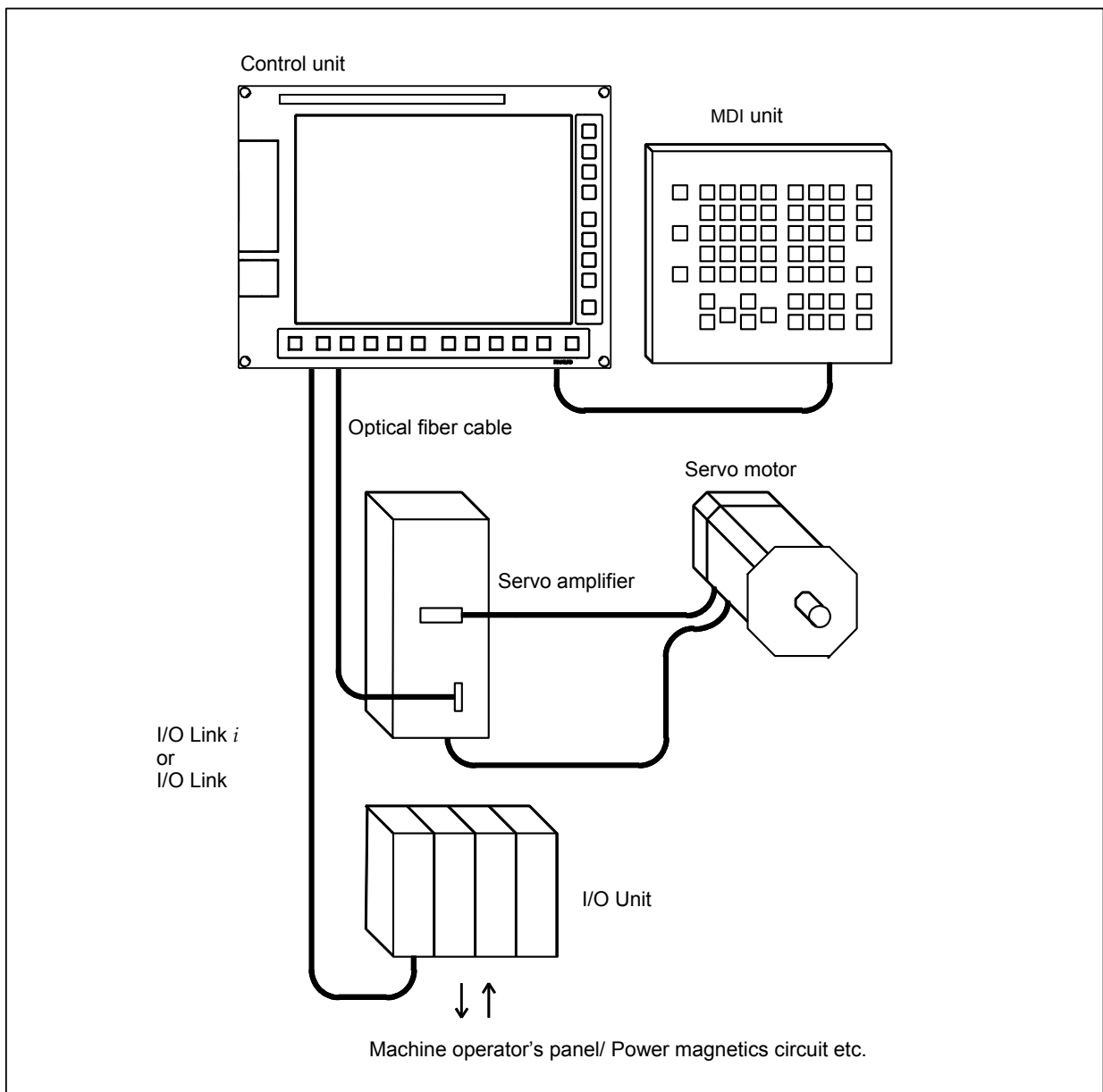

## 2.1.2 Example of the Hardware Configuration of the Stand-alone Type Control Unit

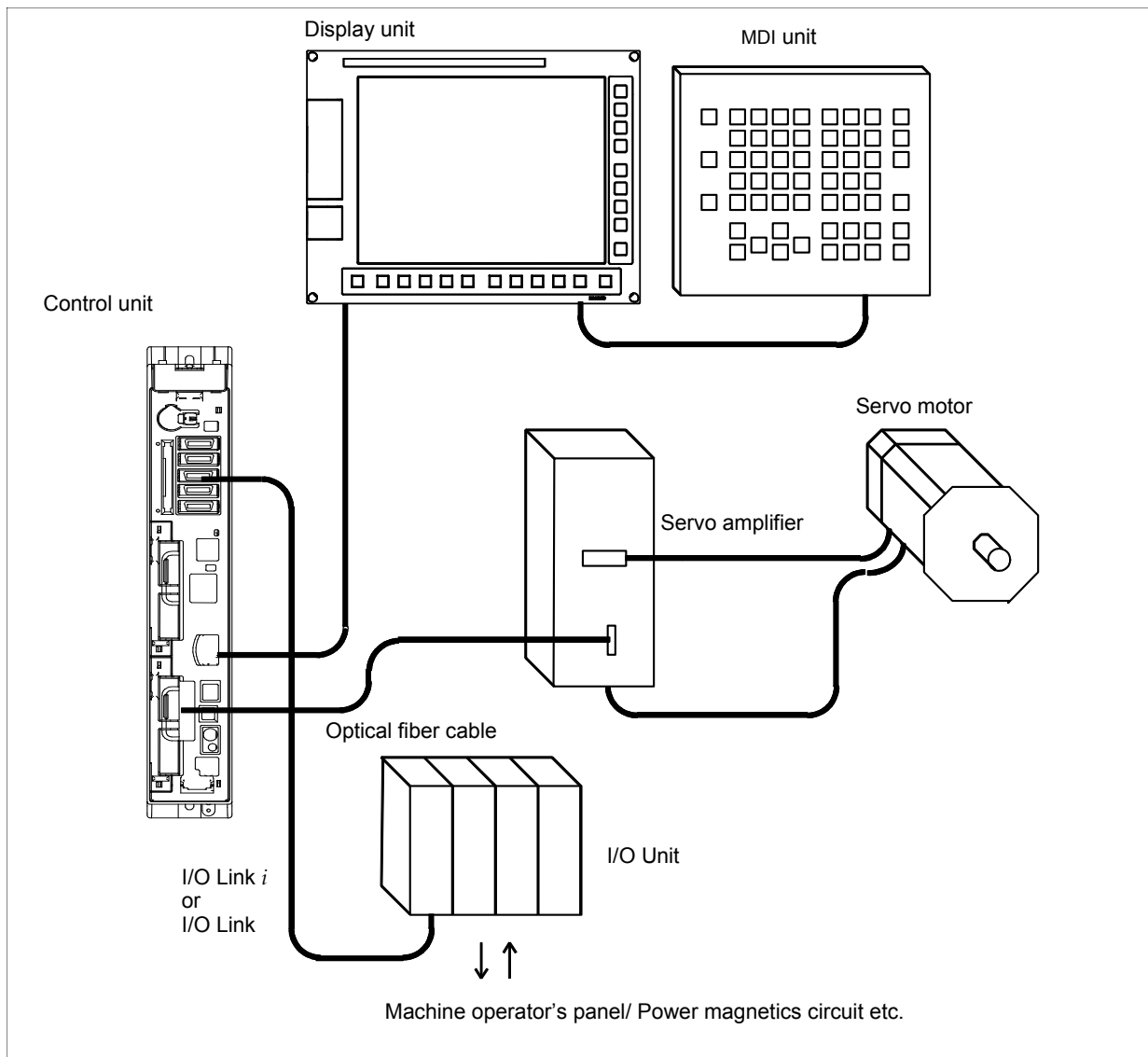

## 2.2 HARDWARE OVERVIEW

### 2.2.1 LCD-mounted Type Control Unit Overview

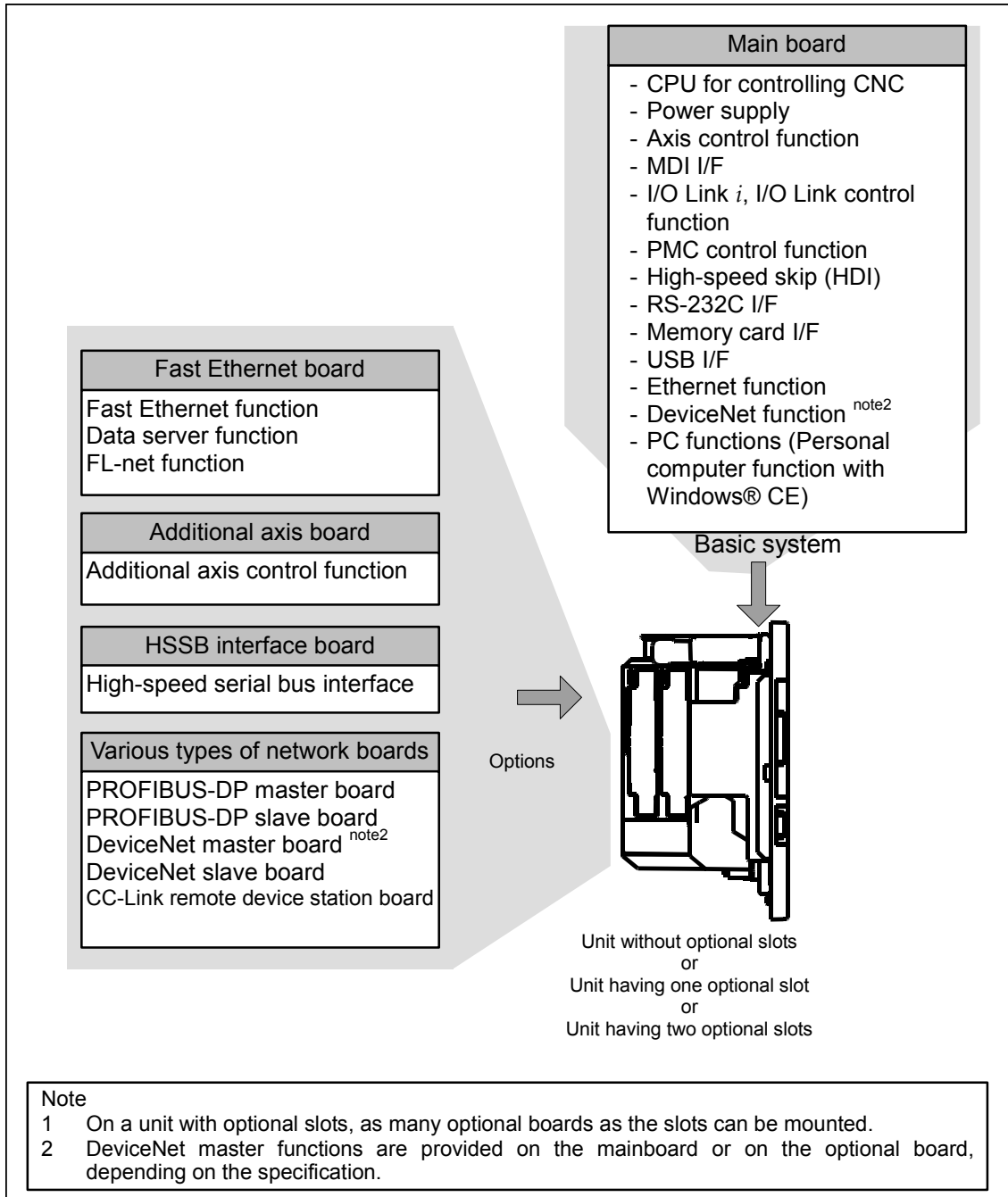

## 2.2.2 Stand-alone Type Control Unit Overview

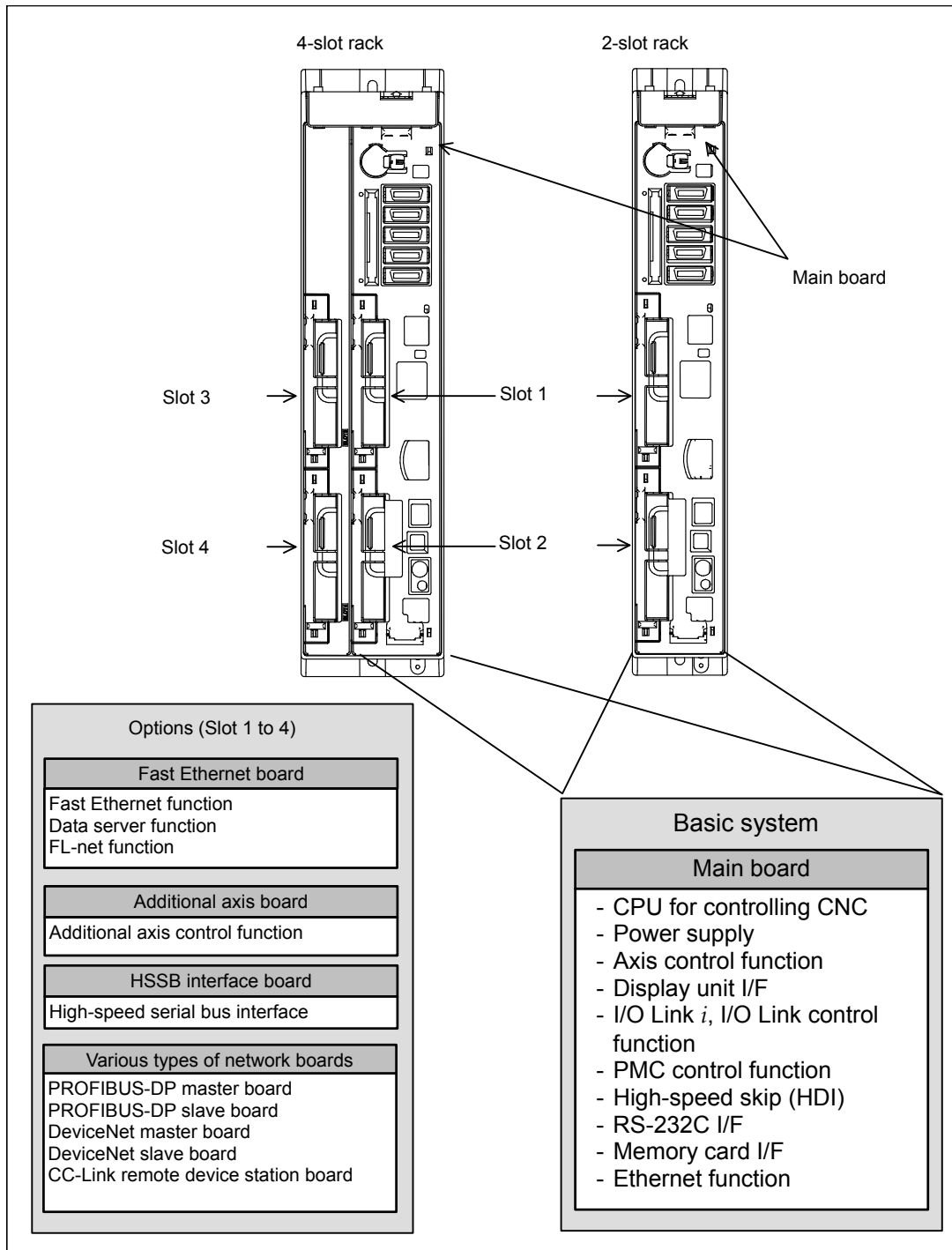

## 2.3 TOTAL CONNECTION DIAGRAMS

### 2.3.1 Control Unit Connection Diagram

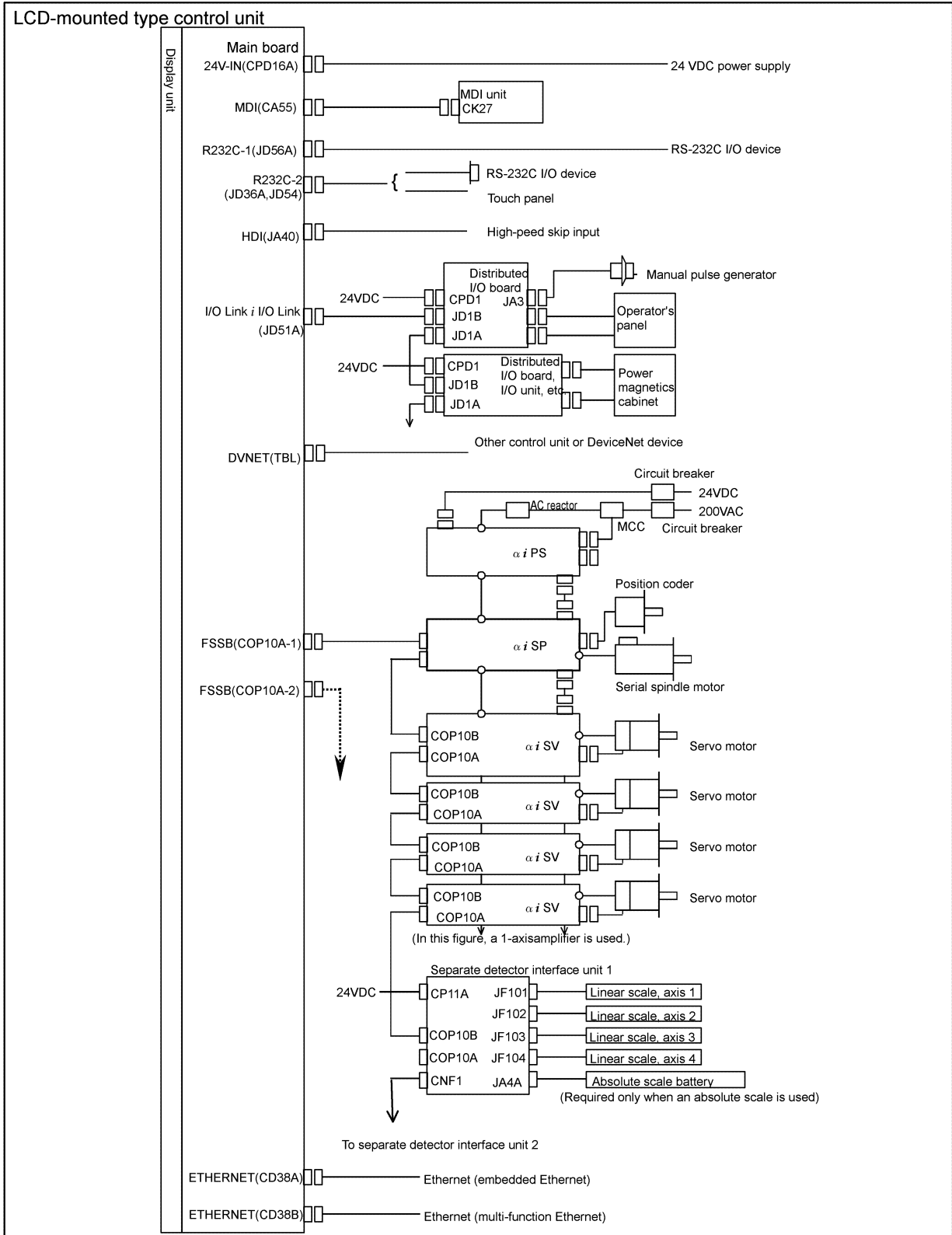

**NOTE**

See the following descriptions for connections unique to control units incorporating personal computer function with Windows Windows® CE.

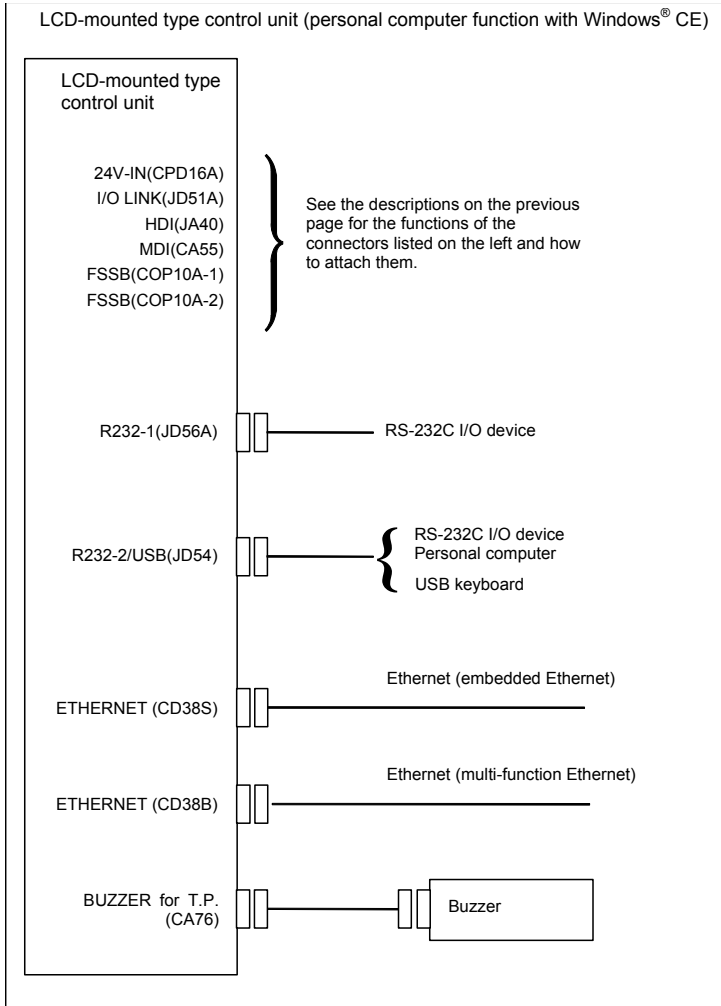

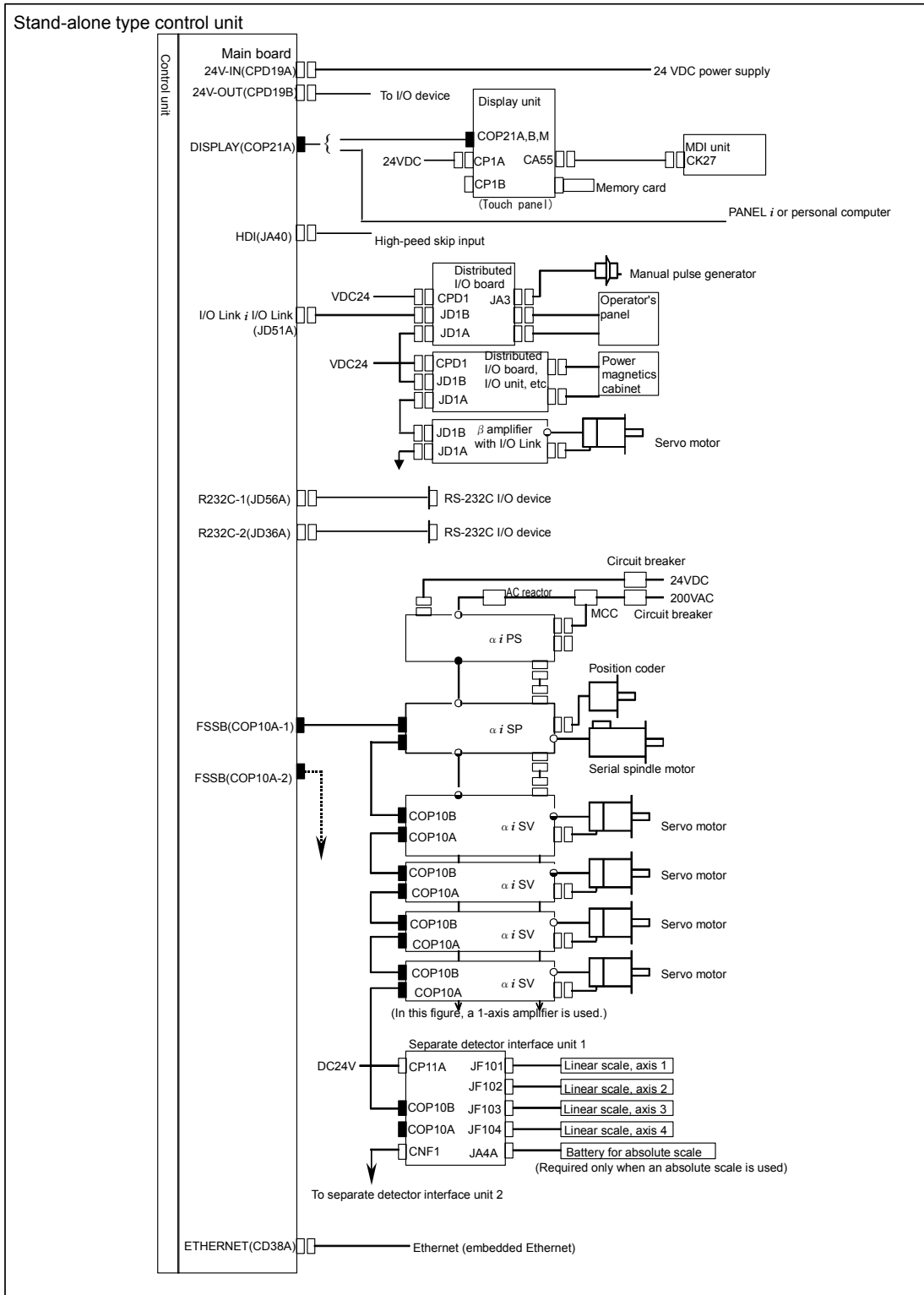

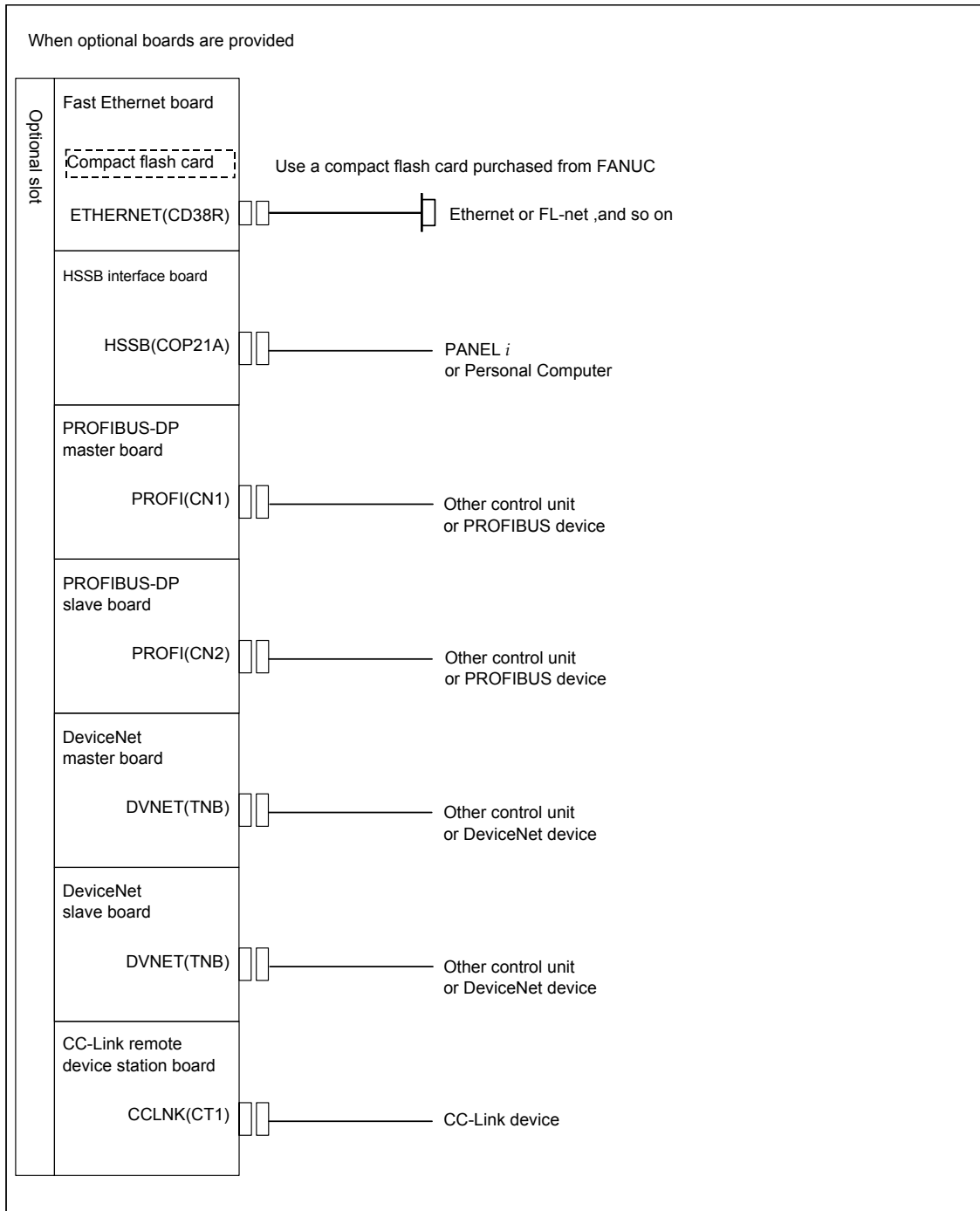



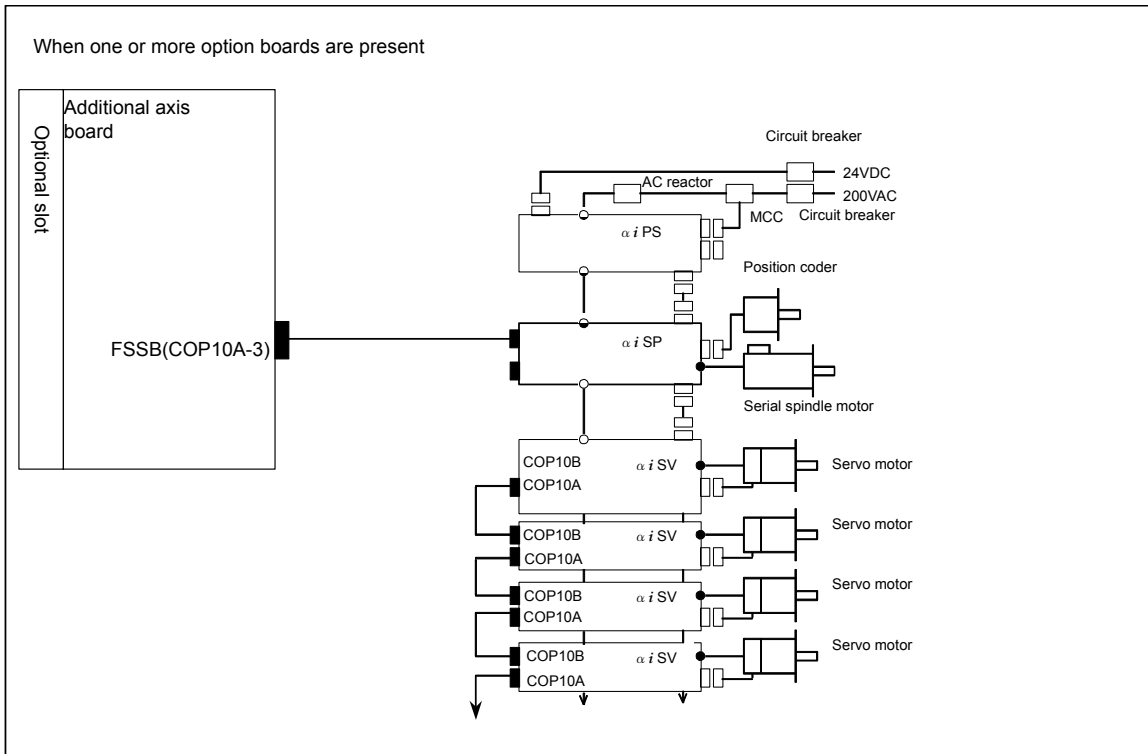

### 2.3.2 Connection Diagram of a Display Unit for the Stand-Alone Type Control Unit

**NOTE**  
See the connection diagram that matches the display unit you are using.

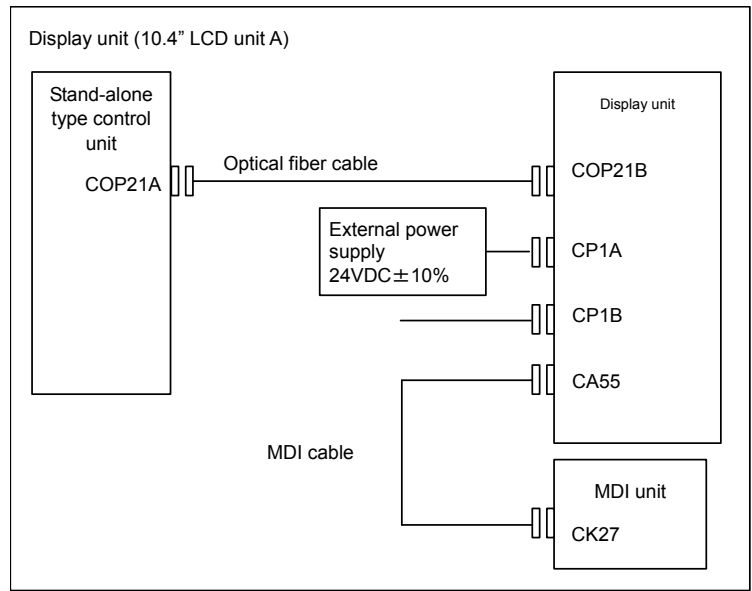

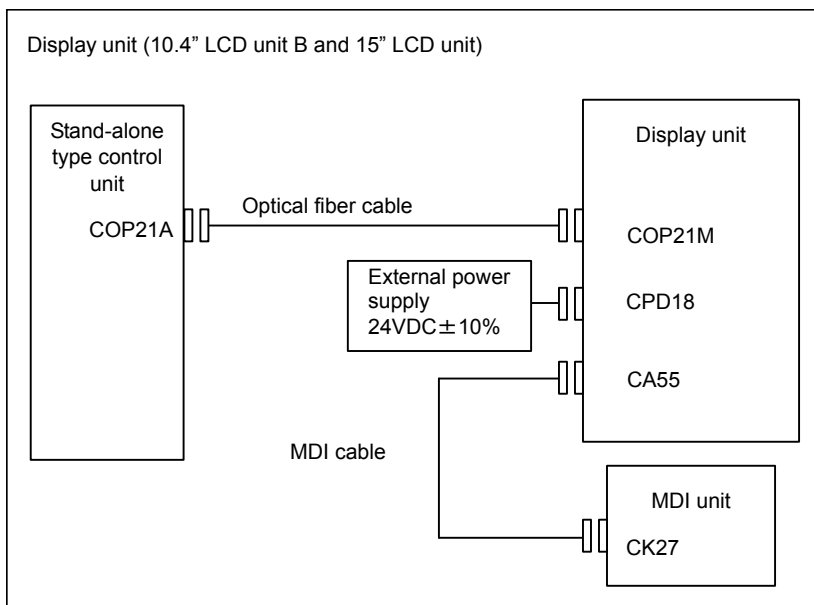
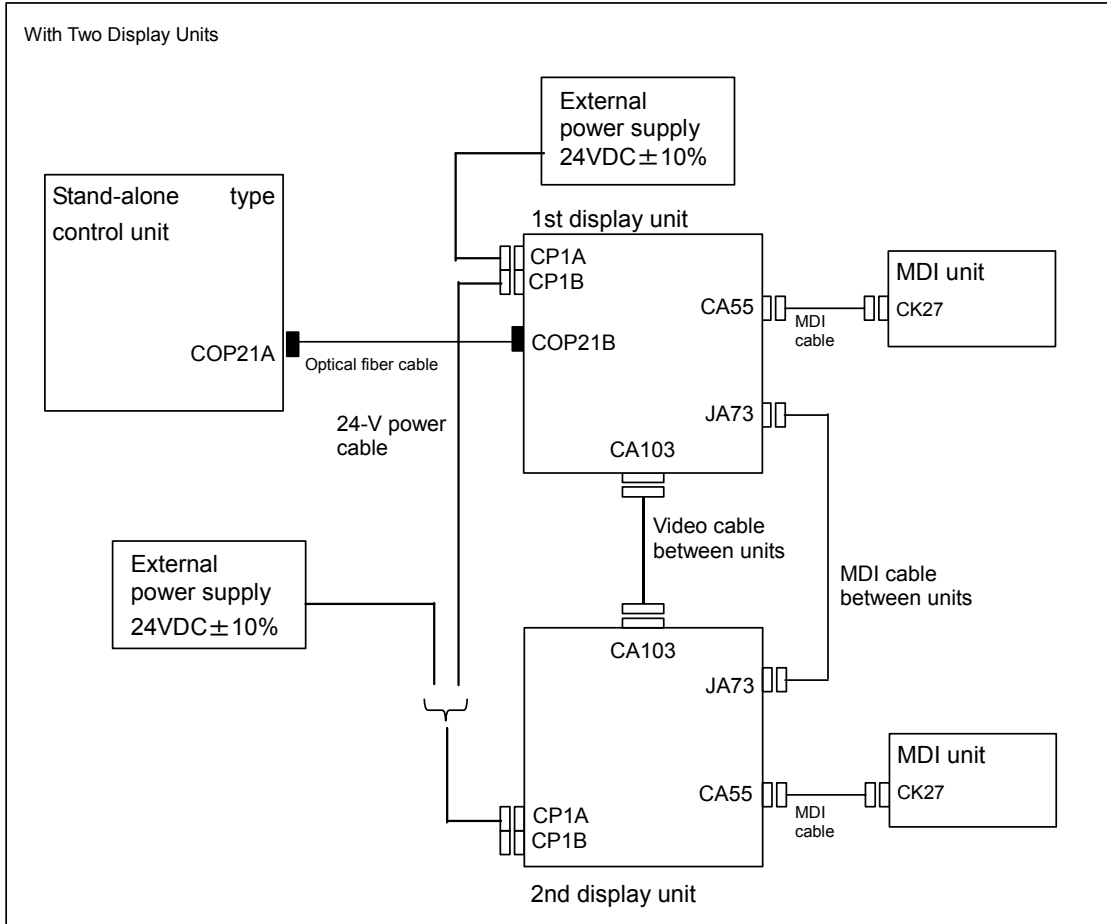

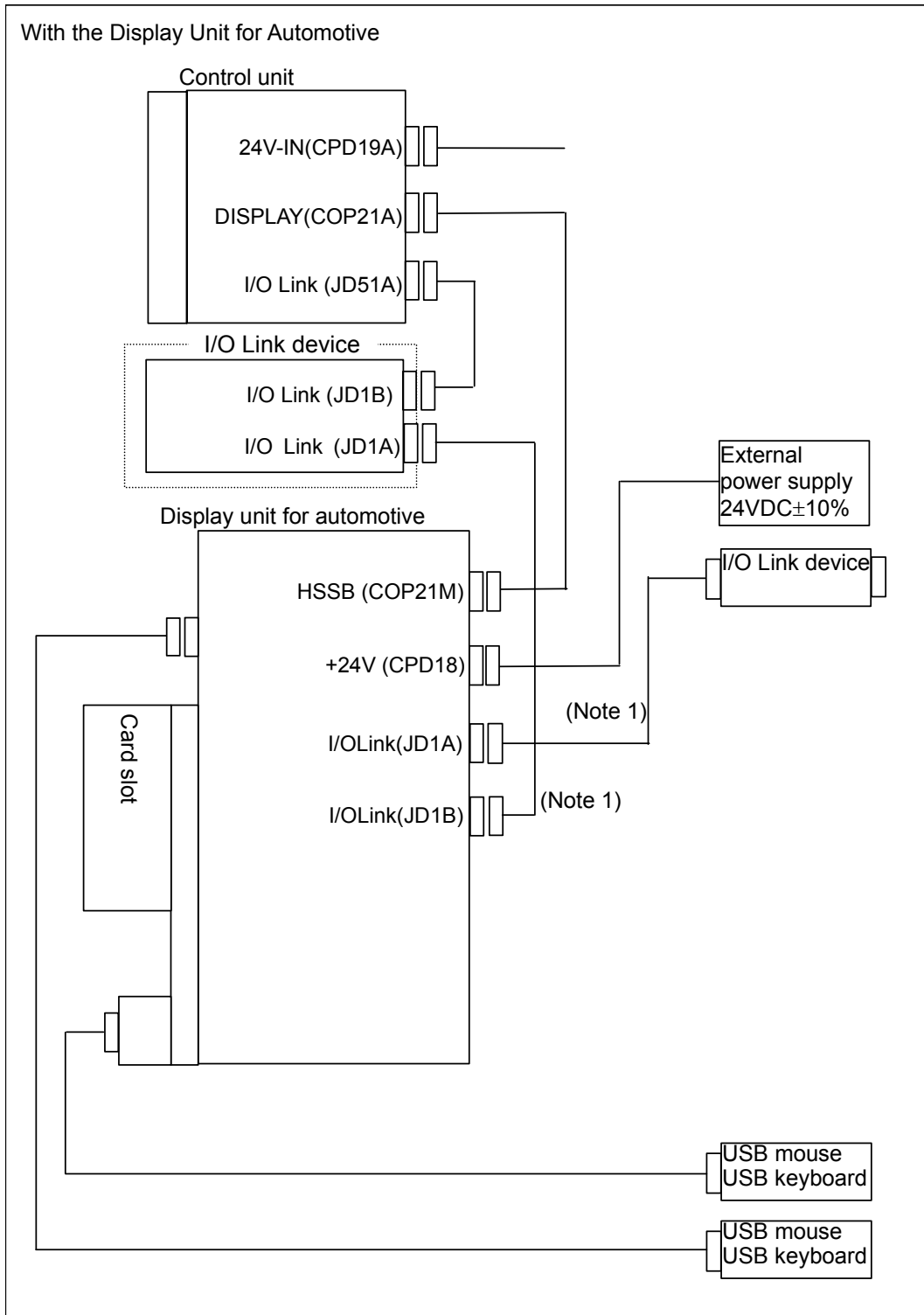

**NOTE**  
 1 The I/O Link interface is optional.  
 2 On the display unit for automobile manufacturers, the MDI unit is built onto the front panel.

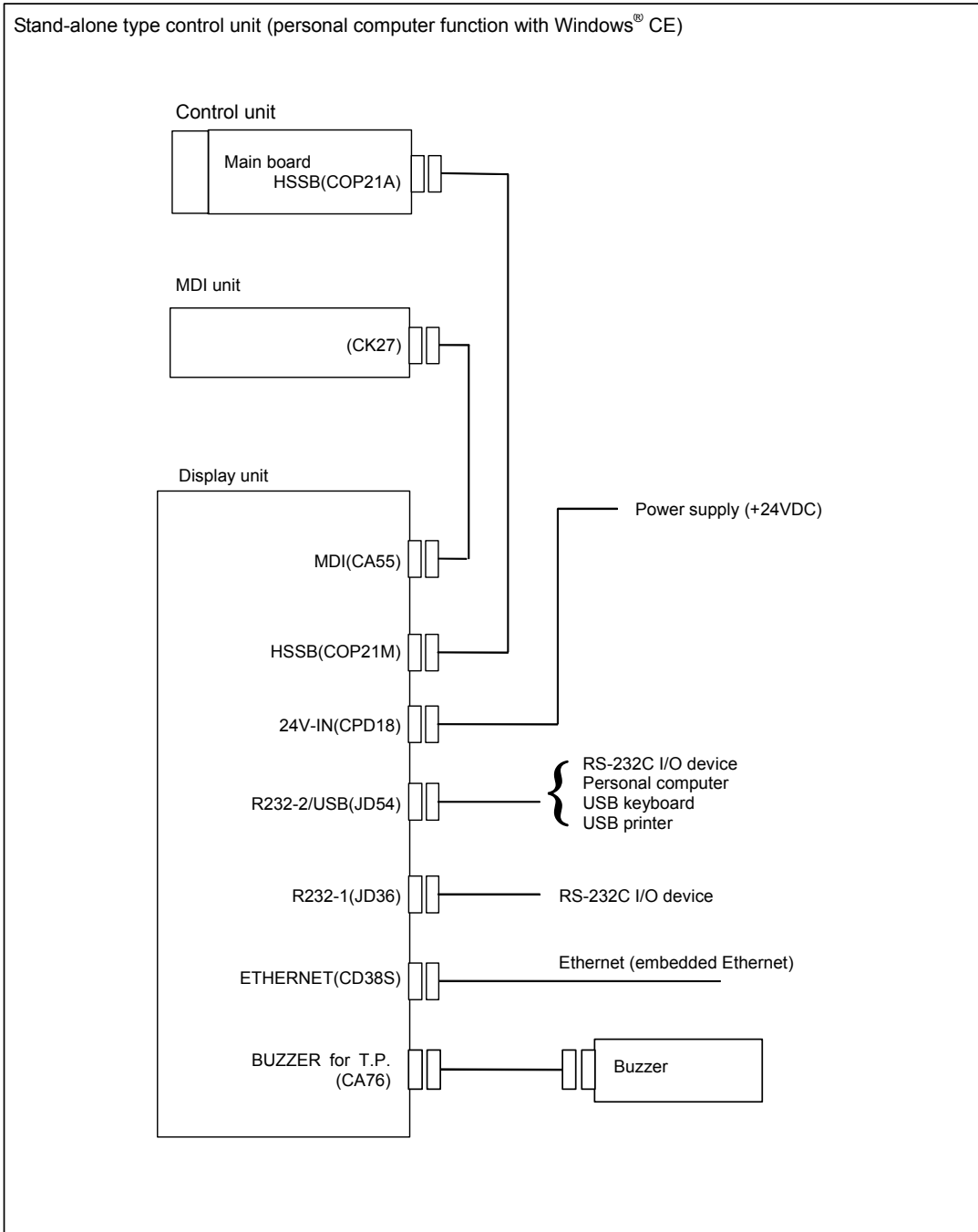

## 2.4 HARDWARE OF LCD-MOUNTED TYPE CONTROL UNIT

### 2.4.1 LCD-mounted Type Control Unit (8.4” LCD Unit and 10.4” LCD Unit A)

- Main board specification

Name	Specification	Remark
Main board	A20B-8200-0720	
	A20B-8200-0721	
	A20B-8200-0723	
	A20B-8200-0724	

- Connector mounting location

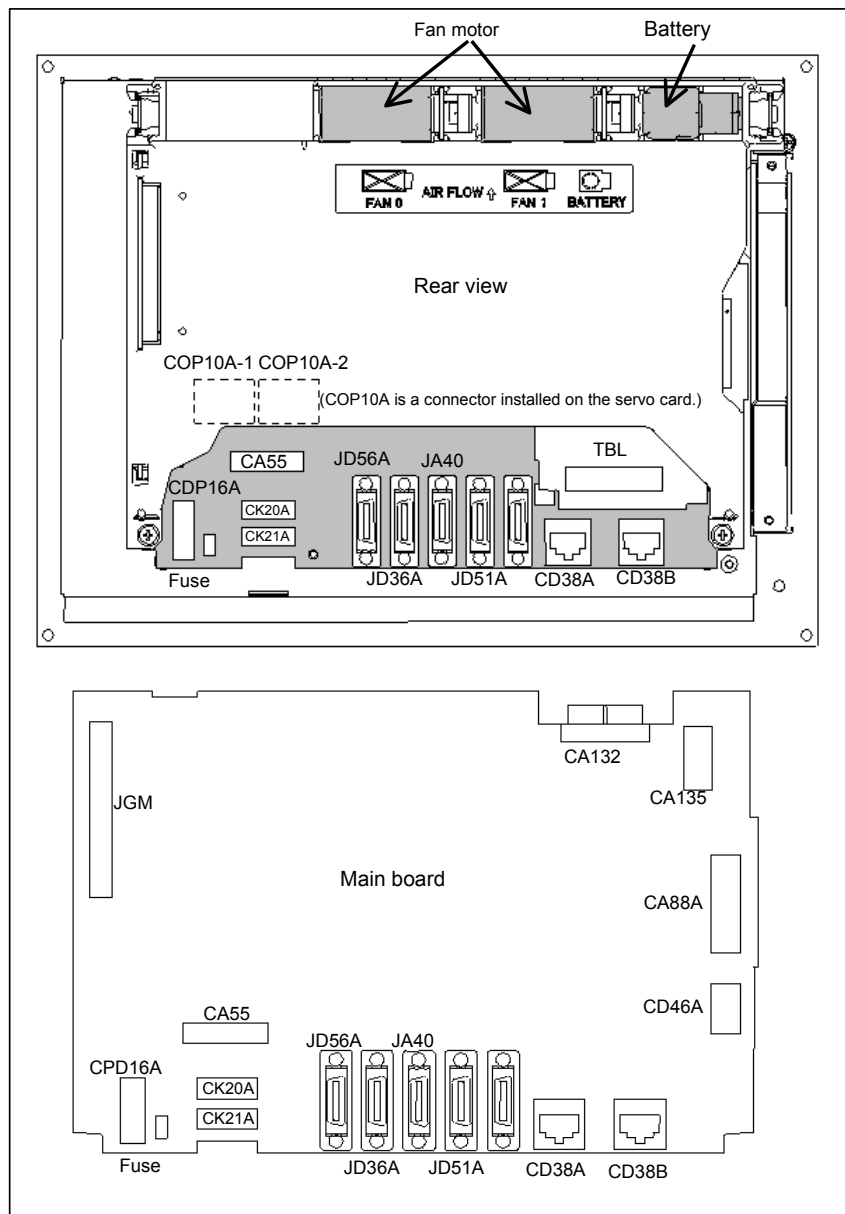

Connector number	Application
COP10A-1, COP10A-2	For FSSB interface
CA55	For MDI
JD56A	For I/O device interface (RS-232C)
JD36A	For I/O device interface (RS-232C)
JA40	For high-speed skip
JD51A	For I/O Link i and I/O Link
CPD16A	For power supply
JGM	For back panel
CA135	For video signal interface
CA88A	For memory card interface
CD46A	For USB port
CK20A	For horizontal soft key
CK21A	For vertical soft key
CA132	For inverter board
CD38A	For Ethernet (Embedded Ethernet)
CD38B	For Ethernet (Multi-function Ethernet)
TBL	For DeviceNet interface

- Locations of printed circuit boards

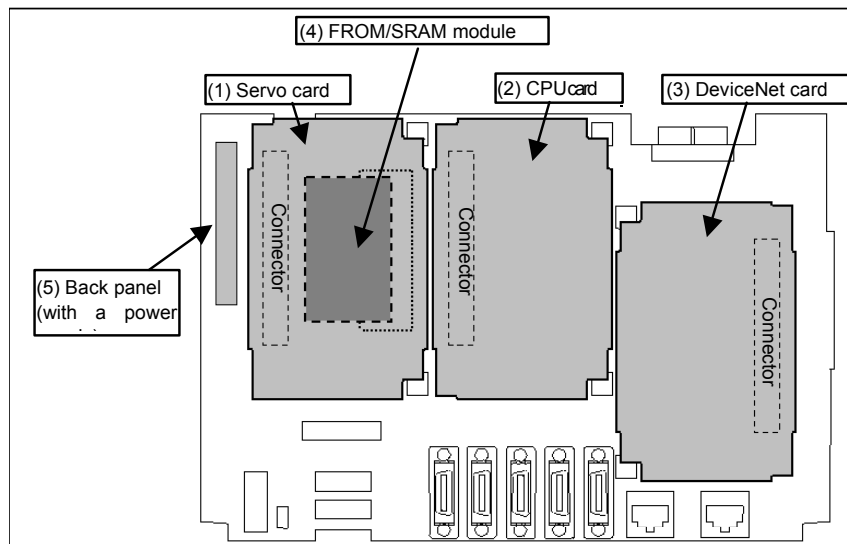

No.	Name	Specification	Remark
(1)	Servo card	A20B-3300-0660	
		A20B-3300-0661	
		A20B-3300-0662	
		A20B-3300-0663	
		A20B-3300-0664	
(2)	CPU card	A20B-3300-0650	
		A20B-3300-0651	
		A20B-3300-0652	
		A20B-3300-0653	
		A20B-3300-0654	
(3)	DeviceNet card	A20B-3200-0020	

No.	Name	Specification	Remark
(4)	FROM/SRAM module	A20B-3900-0250	The FROM stores various control software programs, user software programs, and so forth. The SRAM is a battery-backed memory module.
		A20B-3900-0251	
		A20B-3900-0252	
(5)	Back panel (with power supply)	A20B-8200-0650	
		A20B-8200-0670	
		A20B-8200-0680	

- Block diagram

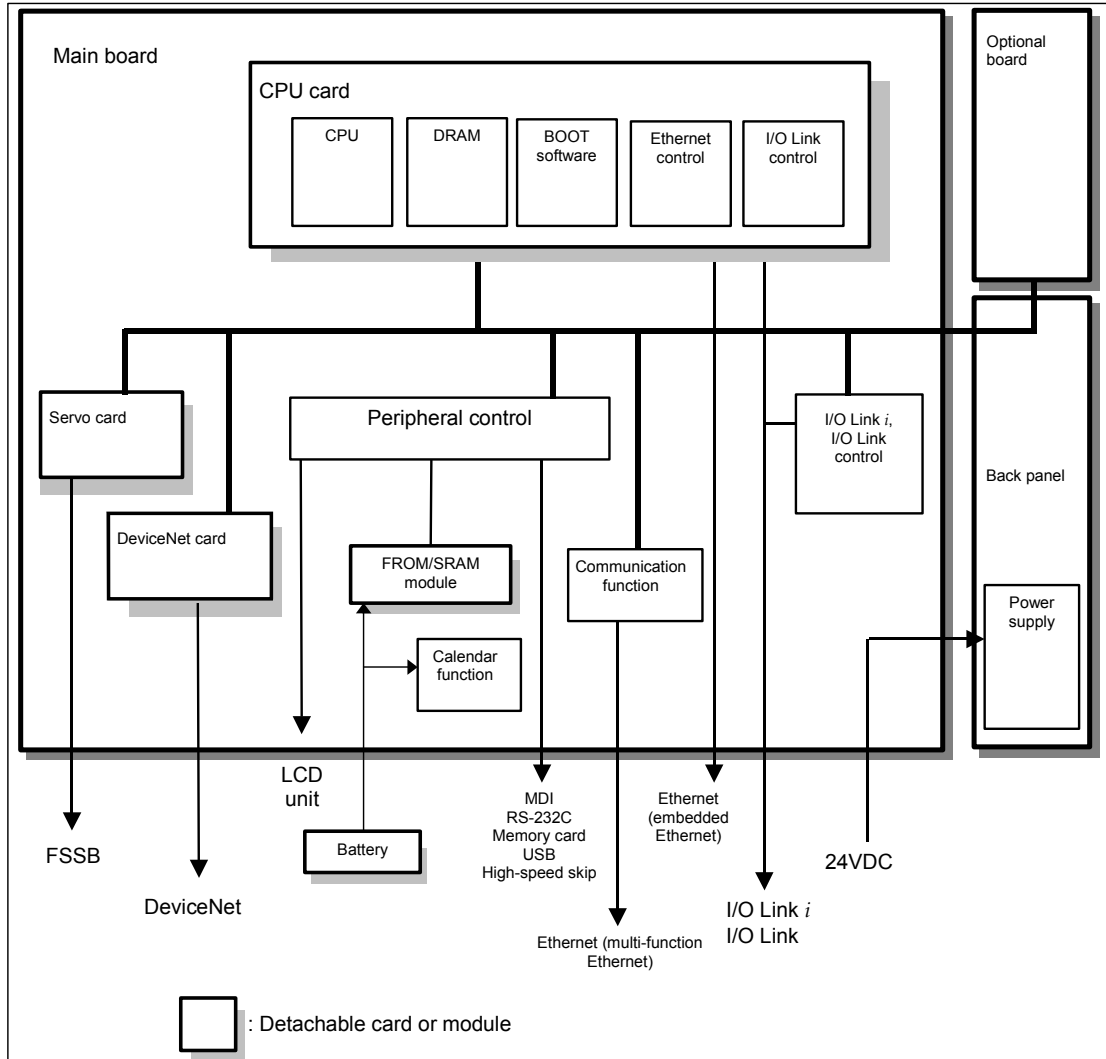

- LED display

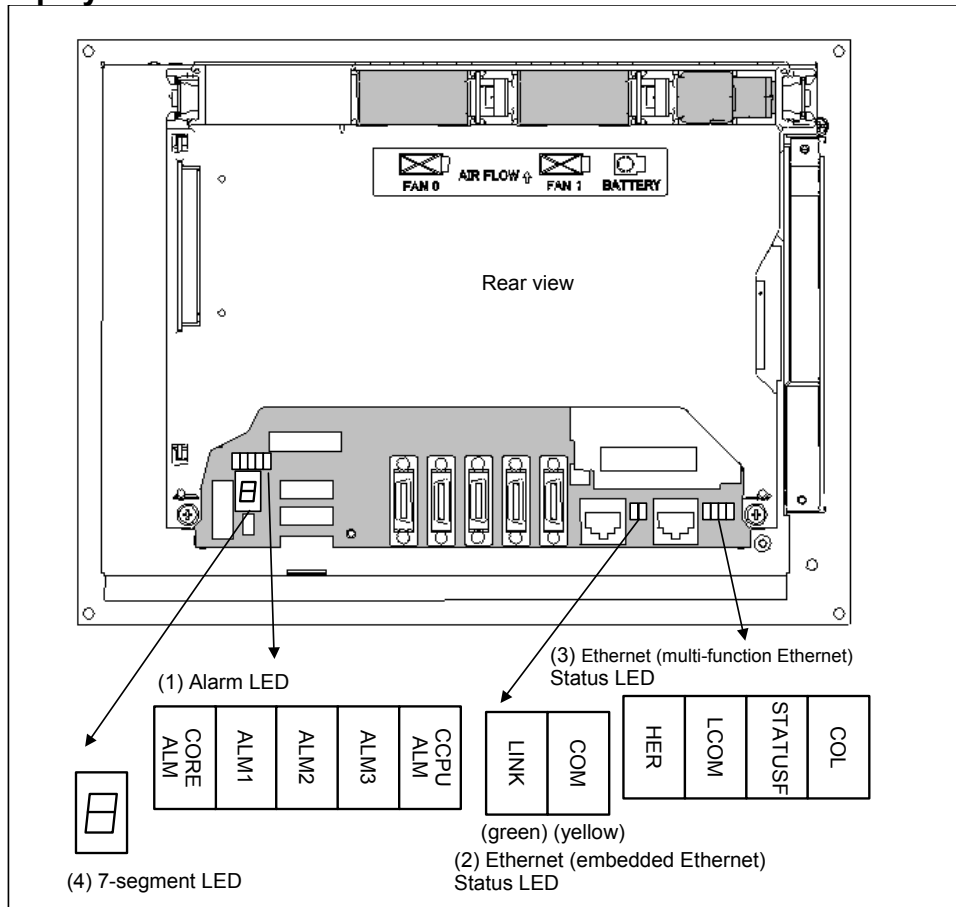

(1) Alarm LED (red) indication

CORE ALM	ALM 1	ALM 2	ALM 3	CCPU ALM	Meaning
◇	□	■	□	◇	Low battery voltage. The battery may be is running out.
◇	■	■	□	◇	Software detected an error and stopped the system.
◇	□	□	■	◇	Hardware detected a failure in the system.
◇	■	□	■	◇	An alarm was issued with the servo card on the main board.
◇	□	■	■	◇	An error was detected in the data of the SRAM on the FROM/SRAM module. The FROM/SRAM module may be faulty, the battery voltage may have dropped, or the main board may be faulty.
◇	■	■	■	◇	Abnormal power supply operation. The cause may be noise or the back panel (with power supply) failure.
◇	◇	◇	◇	■	The CPU card may be faulty.
■	◇	◇	◇	◇	Lights if there is an abnormal condition in the power supply on the main board.

■: On □: Off ◇: Don't care

(2) Ethernet (Embedded Ethernet) statusLED

LED	Meaning
LINK (green)	Turned on when a connection is made with the hub correctly.
COM (yellow)	Turned on when data is transferred.



## (3) Ethernet (Multi-function Ethernet) statusLED

In the following explanations, the LED lighting states are expressed as follows:

□: Off    ■: On    ☆: Blinking

- **LED display transition for STATUSF (power on state)**

LED display	Status	Meaning
□	Power-off	
■	Immediately after power-on	Initial state entered immediately after power-on. If LED is stopped in this condition, the cause is one of the following: → The CNC communication software may not be running normally. Check whether the communication software is installed properly. → The main board may be faulty. Replace the main board.
☆	Start completion	The Multi-function Ethernet has started normally.

- **LED display for STATUSF (during normal operation)**

LED display	Status	Meaning
☆	Normal status	The Multi-function Ethernet is operating normally.

- **LED display for LCOM**

LED display	Status	Meaning
□	Not connected to hub	The board is not connected to the hub properly. The LED stays off also when the power to the hub is off. Check whether the board is connected to the hub properly.
■	Connected to hub	The board is connected to the hub.
☆	Transmission/reception in progress	Data is being transmitted or received.

- **LED display for COL**

LED display	Status	Meaning
□	Normal status	The Multi-function Ethernet is operating normally.
■ ☆	Collision occurs. (Data collision occurs.)	The LED is on or blinks at short intervals when the Ethernet communication traffic (communication amount) is high or ambient noise is high.

- **LED display for HER**

LED display	Status	Meaning
□	Normal status	The Multi-function Ethernet is operating normally.
■	Error detected in the Ethernet circuit on the main board	The cause may be the faulty main board or a malfunction due to noise.
☆	Error detected in the software	

## (4) 7-segment LED

See Appendix E, "LED Display".

- Inverter board specification

Name		Specification	Remark
Inverter board	For 8.4-inch LCD	A20B-8200-0663	
	For 10.4-inch LCD	A20B-8200-0662	

- Configuration of the inverter

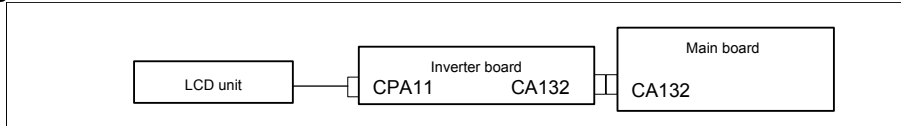

- Location of the inverter board

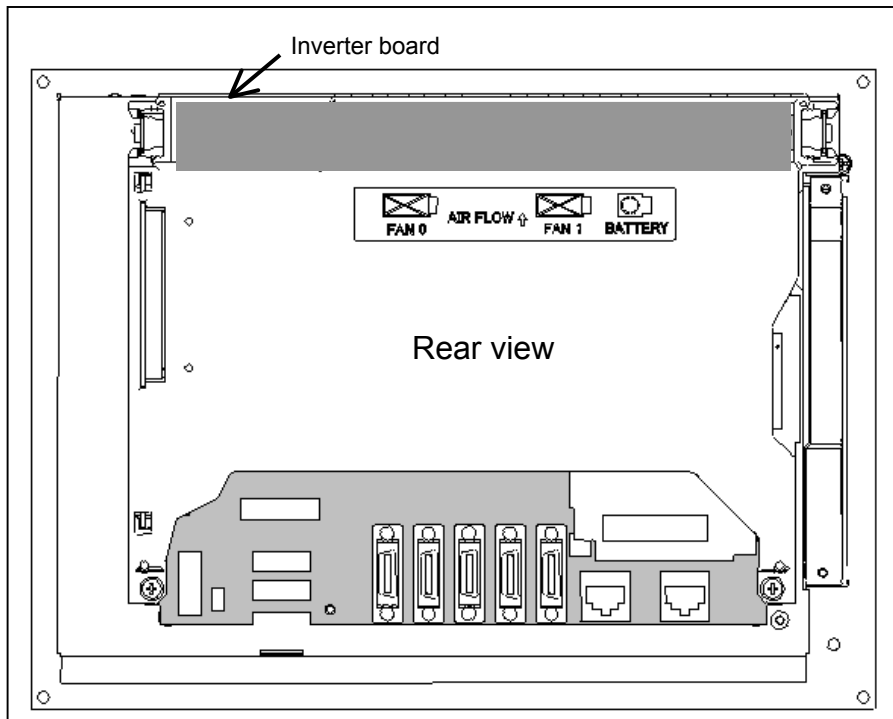

**DeviceNet card  
Connector and LED mounting location**

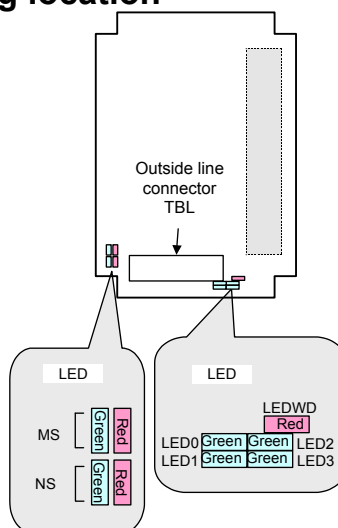

This card provides four green LEDs (LED0 to LED3) and one red LED (LEDWD) for status indication. In addition, it provides two types of LED units (MS and NS) that have one red LED and one green LED.

Name	Color	Meaning
LED0 to 3	Green	Indicates the activation state of the DeviceNet application software.
LEDWD	Red	Indicates an error on the DeviceNet card.
MS	Green	Indicates the module status, which is the status of the local node.
	Red	
NS	Green	Indicates the network status, which is the status of the entire network including the local node.
	Red	

In the following explanations, the LED lighting states are expressed as follows:

□: Off    ■: On    ☆: Blinking    ◇: Don't care

**LED display transition for LED0, LED1, LED2, and LED3 (during power-on)**

LED 3 2 1 0	Status after power-on	Action when stopped after power-on
□□□□	Power-off	
■ ■ ■ ■	After power-on, the DeviceNet application software does not start.	The DeviceNet application software is not running normally. Check whether the software is installed properly.
□□□□	Initializing the firmware.	Replace the DeviceNet card.
□□□■	Checking memory.	
□□■□	Recognizing the firmware.	
□□■■■	Reading DeviceNet parameters.	Confirm that DeviceNet master function (software option) has been purchased.
□■□□	Verifying that DeviceNet parameter "NETWORK" is set to "ONLINE."	Set DeviceNet parameter "NETWORK" to "ONLINE."
□■□■	Setting the bus parameter in DeviceNet parameters.	Replace the DeviceNet card.
□■■□	Setting the slave parameter in DeviceNet parameters.	Set the slave parameter in DeviceNet parameters correctly. If there is no problem with the setting, replace the DeviceNet card.
□■■■	Checking duplicate MAC IDs.	Check duplication with the MAC ID of a slave device. Check if cables are connected correctly. Check if power for communication is correctly supplied. Check if slave devices are turned on.
■□□□	The DeviceNet application software has been initialized and I/O communication starts.	

**LED display for LED1, LED2, LED3, and LED4 (when abnormality occurs)**

LED 3 2 1 0	Status	Meaning
□□□□ ↑ ↓ ■ ■ ■ ■ (Repetition)	Card failure	The DeviceNet card failed. Replace the DeviceNet card.

**LED display for LEDWD**

LED display	Status	Meaning
■	Card failure	The DeviceNet card failed. Replace the DeviceNet card.

**LED display of MS and NS (during normal operation)**

LED display	Status	Meaning
MS □ NS □	Immediately after power-on	The MPU is being reset.
MS ☆ green NS □	Initializing	The firmware is making a initialization.
MS ■ green NS □	Checking duplication of MAC IDs	The firmware is checking duplicated MAC IDs.
MS ■ green NS ☆ green	I/O communication stopped	The firmware is stopping I/O communication.
MS ■ green NS ■ green	I/O communication in advance	The firmware is successfully performing I/O communication.

**LED display of MS and NS (during occurrence of an error)**

LED display	Status	Error and action
MS ☆ red NS ◇	Card failure	A MAC ID or communication rate setting error occurred or the DeviceNet card failed. When the setting is correct, replace the card.
MS ■ red NS □	Card failure	The DeviceNet card failed. Replace the card.
MS ◇ NS ■ red	Duplicate MAC IDs	MAC IDs are duplicate. Verify the following: → MAC IDs are not duplicate by check the MAC IDs of all nodes.
	Busoff detection	Communication stopped because a communication error occurred frequently. Verify the following: → The communication rates of all nodes are set to the same value. → The cable length is appropriate. → The cable is not loose or broken. → A terminal is placed on only both ends of the main line. → There is not much noise.
MS ◇ NS □	Network power failure	Power for communication is not supplied. Verify the following: → Power for communication is properly supplied.
	Transmission error	Transmission is not completed successfully. Verify the following: → All slaves are turned on. → There is no other master on the network. → The communication rates of all nodes are set to the same value. → The cable length is appropriate. → The cable is not loose or broken. → A terminal is placed on only both ends of the main line. → There is not much noise.

LED display	Status	Error and action
MS ◇ NS ☆ red	Slave not present	No slaves are present. Verify the following: → The slave is turned on. → The communication rates of all nodes are set to the same value. → The cable length is appropriate. → The cable is not loose or broken. → A terminal is placed on only both ends of the main line. → There is not much noise.
	Slave I/O size mismatch	The slave I/O size setting does not match the setting of the actual slave. Verify the following: → The slave I/O size setting matches the setting of the actual slave.
	I/O communication error	I/O communication timed out. Verify the following: → The communication rates of all nodes are set to the same value. → The cable length is appropriate. → The cable is not loose or broken. → A terminal is placed on only both ends of the main line. → There is not much noise.

## 2.4.2 LCD-mounted Type Control Unit (10.4" LCD Unit B and 15" LCD Unit)

### Main board specification

Name	Specification	Remark
Main board	For 10.4" LCD	A20B-8200-0708
		A20B-8200-0709
		A20B-8200-0718
		A20B-8200-0719
	For 15" LCD	A20B-8200-0702
		A20B-8200-0706
		A20B-8200-0712
		A20B-8200-0716

### - Connector mounting location

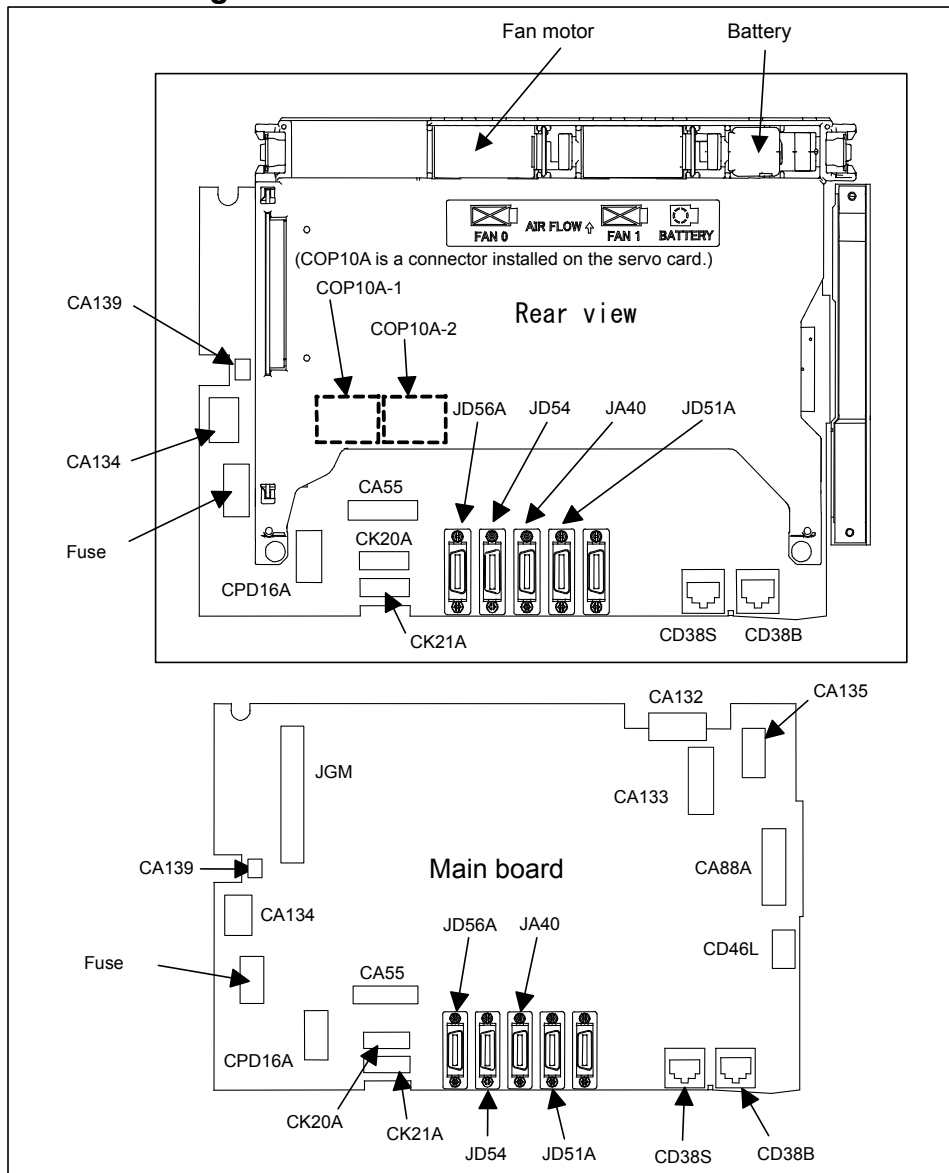

Connector number	Application
COP10A-1, COP10A-2	For FSSB interface
CA55	For MDI

Connector number	Application
JD56A	For I/O device interface (RS-232C)
JD54	For I/O device interface (RS-232C)
JA40	For high-speed skip
JD51A	For I/O Link i and I/O Link
CPD16A	For power supply
JGM	For back panel
CA133	For video signal interface (for 10.4"LCD)
CA135	For video signal interface (for 15"LCD)
CA88A	For memory card interface
CD46L	For USB port
CK20A	For horizontal soft key
CK21A	For vertical soft key
CA132	For inverter board (for 10.4"LCD) For fan adapter board (for 15"LCD)
CD38S	Ethernet (Embedded Ethernet)
CD38B	Ethernet (Multi-function Ethernet)
CA139	For touch panel interface
CA134	For inverter board (for 15"LCD)

- Card and back panel mounting location

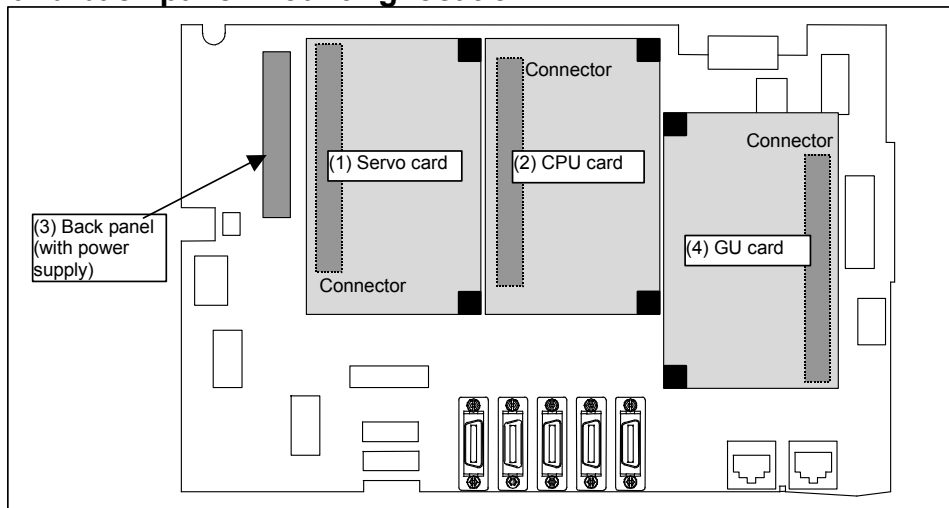

No.	Name	Specification	Remark
(1)	Servo card	See Subsection 2.4.1, "LCD-mounted Type Control Unit (8.4" LCD Unit and 10.4" LCD Unit A)".	
(2)	CPU card		
(3)	Back panel (with power supply)		
(4)	GUI card	A20B-3300-0670	

- FROM/SRAM module and compact flash card mounting location

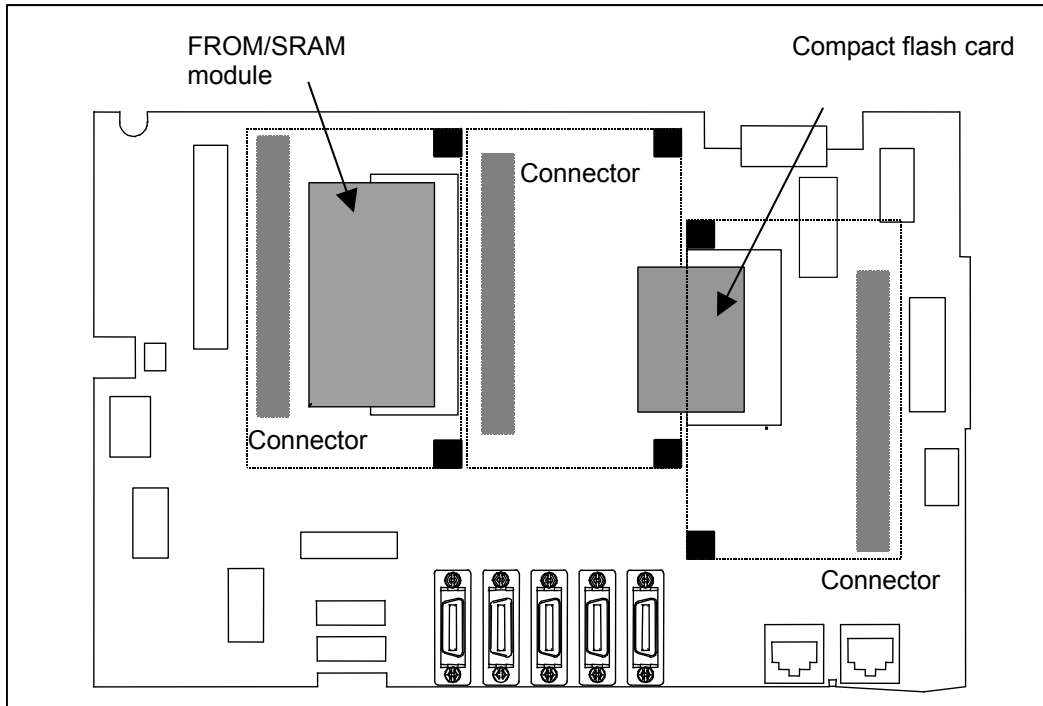

A compact flash card is mounted on the main board.

No.	Name	Specification	Remark
(1)	FROM/SRAM module	A20B-3900-0260	The FROM stores various control software programs, user software programs, and so forth. The SRAM is a battery-backed memory module.
(2)	Compact flash card	A02B-0323-C990#A	Including software

- Block diagram

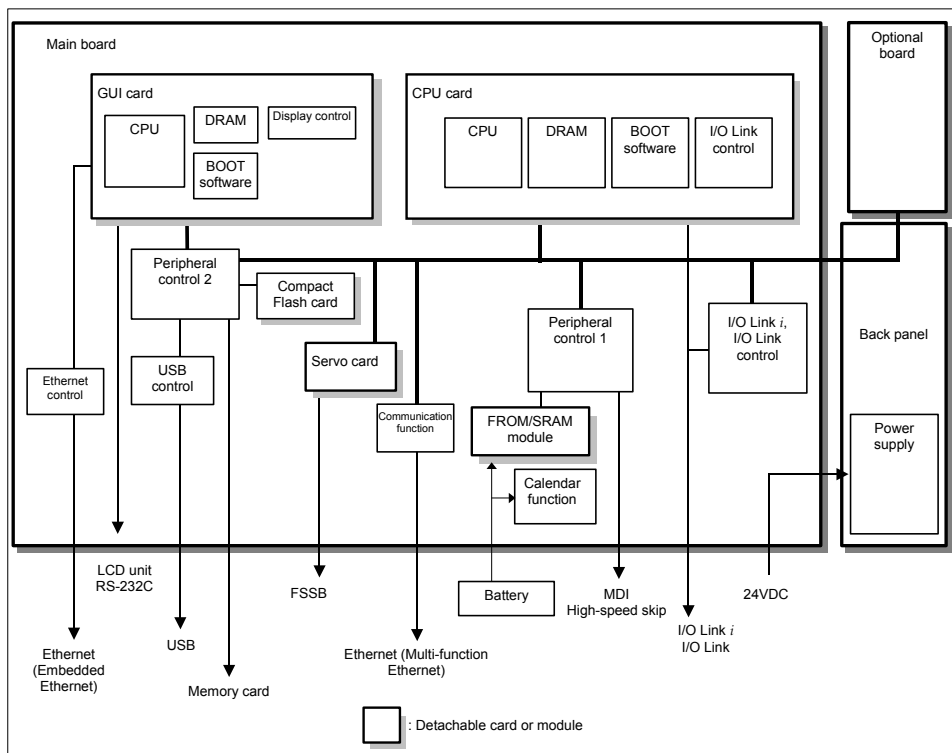



- LED display

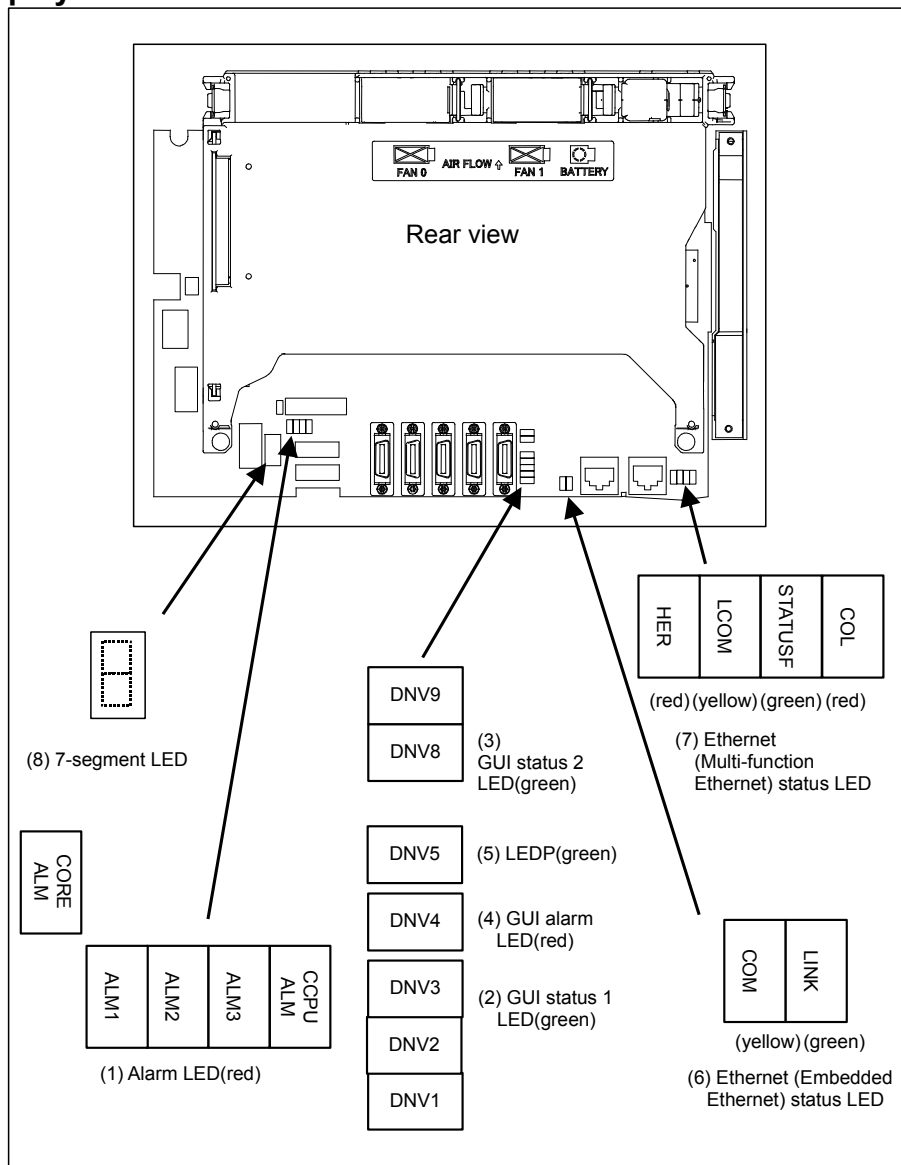

(1) Alarm LED (red LED)

CORE ALM	ALM 1	ALM 2	ALM 3	CCPU ALM	Meaning
◇	□	■	□	◇	Low battery voltage. The battery may be is running out.
◇	■	■	□	◇	Software detected an error and stopped the system.
◇	□	□	■	◇	Hardware detected a failure in the system.
◇	■	□	■	◇	An alarm was issued with the servo card on the main board.
◇	□	■	■	◇	An error was detected in the data of the SRAM on the FROM/SRAM module. The FROM/SRAM module may be faulty, the battery voltage may have dropped, or the main board may be faulty.
◇	■	■	■	◇	Abnormal power supply operation. The cause may be noise or the back panel (with power supply) failure.
◇	◇	◇	◇	■	The CPU card may be faulty.
■	◇	◇	◇	◇	Lights if there is an abnormal condition in the power supply on the main board.

■: On □: Off ◇: Don't care

(2) GUI status 1 LED (green LED)  
Reserved.

(3) GUI status 2 LED (green LED)

LED	Meaning
DNV8 (LED2)	Indicates the operation status of the screen display function.
DNV9 (LED1)	Indicates the operation status of the screen display function.

■: On □: Off

(4) GUI alarm LED (red LED)

LED	Meaning
DNV4 (RAME)	Common RAM error. The main board may be faulty.

(5) LEDP (green LED)

LED	Meaning
DNV5 (LEDP)	Turned on when power is supplied to the GUI card.

(6) Ethernet (Embedded Ethernet) status LED

LED	Meaning
LINK (green)	Turned on when a connection is made with the hub correctly.
COM (yellow)	Turned on when data is transferred.

## (7) Ethernet (Multi-function Ethernet) status LED

In the following explanations, the LED lighting states are expressed as follows:

□: Off    ■: On    ☆: Blinking

## - LED display transition for STATUSF (power on state)

LED display	Status	Meaning
□	Power-off	
■	Immediately after power-on	Initial state entered immediately after power-on. If LED is stopped in this condition, the cause is one of the following: → The CNC communication software may not be running normally. Check whether the communication software is installed properly. → The main board may be faulty. Replace the main board.
☆	Start completion	The Multi-function Ethernet has started normally.

## - LED display for STATUSF (during normal operation)

LED display	Status	Meaning
☆	Normal status	The Multi-function Ethernet is operating normally.

## - LED display for LCOM

LED display	Status	Meaning
□	Not connected to hub	The board is not connected to the hub properly. The LED stays off also when the power to the hub is off. Check whether the board is connected to the hub properly.
■	Connected to hub	The board is connected to the hub.
☆	Transmission/reception in progress	Data is being transmitted or received.

## - LED display for COL

LED display	Status	Meaning
□	Normal status	The Multi-function Ethernet is operating normally.
■ ☆	Collision occurs. (Data collision occurs.)	The LED is on or blinks at short intervals when the Ethernet communication traffic (communication amount) is high or ambient noise is high.

## - LED display for HER

LED display	Status	Meaning
□	Normal status	The Multi-function Ethernet is operating normally.
■	Error detected in the Ethernet circuit on the main board	The cause may be the faulty main board or a malfunction due to noise.
☆	Error detected in the software	

## (8) 7-segment LED

See Appendix E, "LED Display".

**- Inverter board and fan adapter board**

Name	Specification	Remark
Inverter board	For 10.4" LCD (working also as fan adapter board)	A20B-8200-0662
	For 15" LCD	A14L-0168-0001
Fan adapter board	For 10.4" LCD (working also as fan adapter board)	Works also as the inverter board mentioned above.
	For 15" LCD	A20B-8200-0669
Main board-to-inverter board connection cable	For 15" LCD	A660-4042-T076#L75R00

**Configuration of the inverter**

(1) For control unit with 10.4" LCD

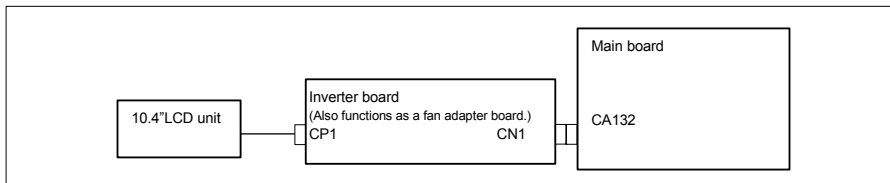

(2) For control unit with 15" LCD

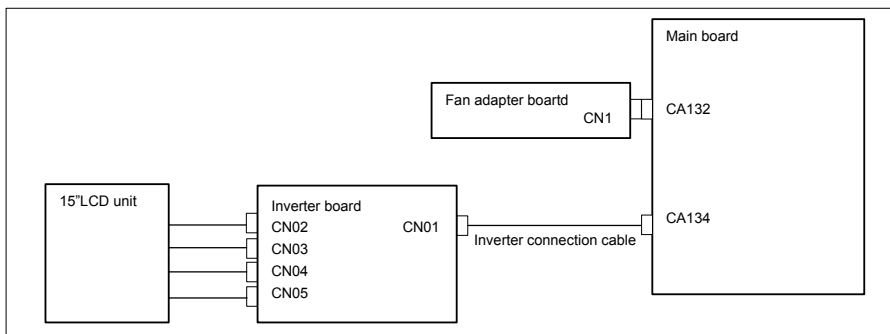

### Locations of the inverter board and fan adapter board

(1) For control unit with 10.4" LCD

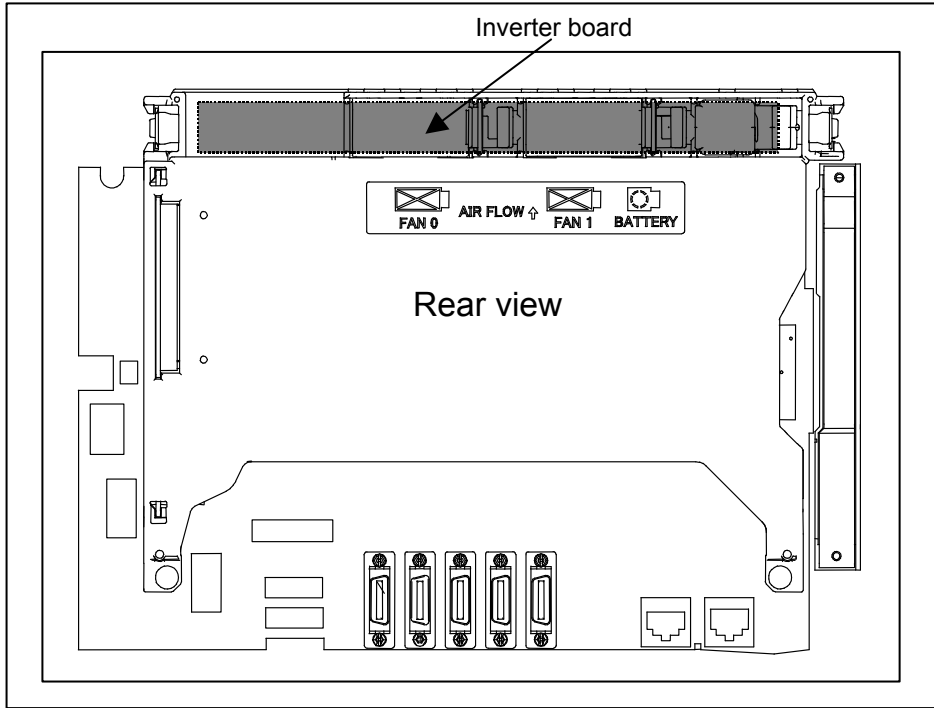

(2) For control unit with 15" LCD

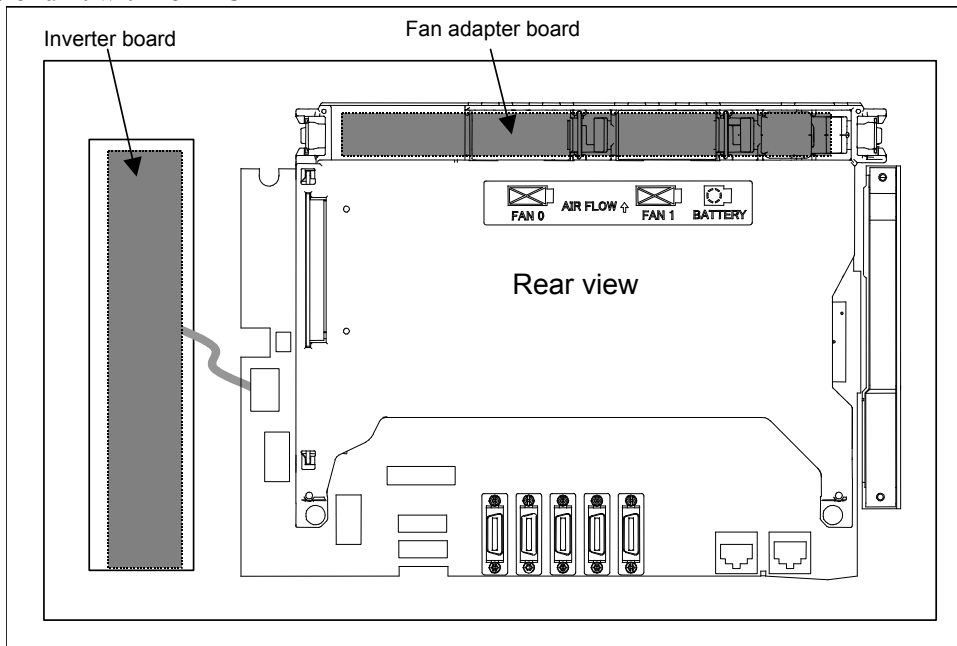

### 2.4.3 LCD-mounted Type Control Unit (with Personal Computer Function with Windows®CE) Hardware

- Main board specification

Name		Specification	Remark
Main board	For 10.4" LCD	A20B-8200-0700	
		A20B-8200-0704	
		A20B-8200-0710	
		A20B-8200-0714	
	For 12.1" LCD	A20B-8200-0703	
		A20B-8200-0707	
		A20B-8200-0713	
		A20B-8200-0717	
	For 15" LCD	A20B-8200-0701	
		A20B-8200-0705	
		A20B-8200-0711	
		A20B-8200-0715	

- Connector mounting location

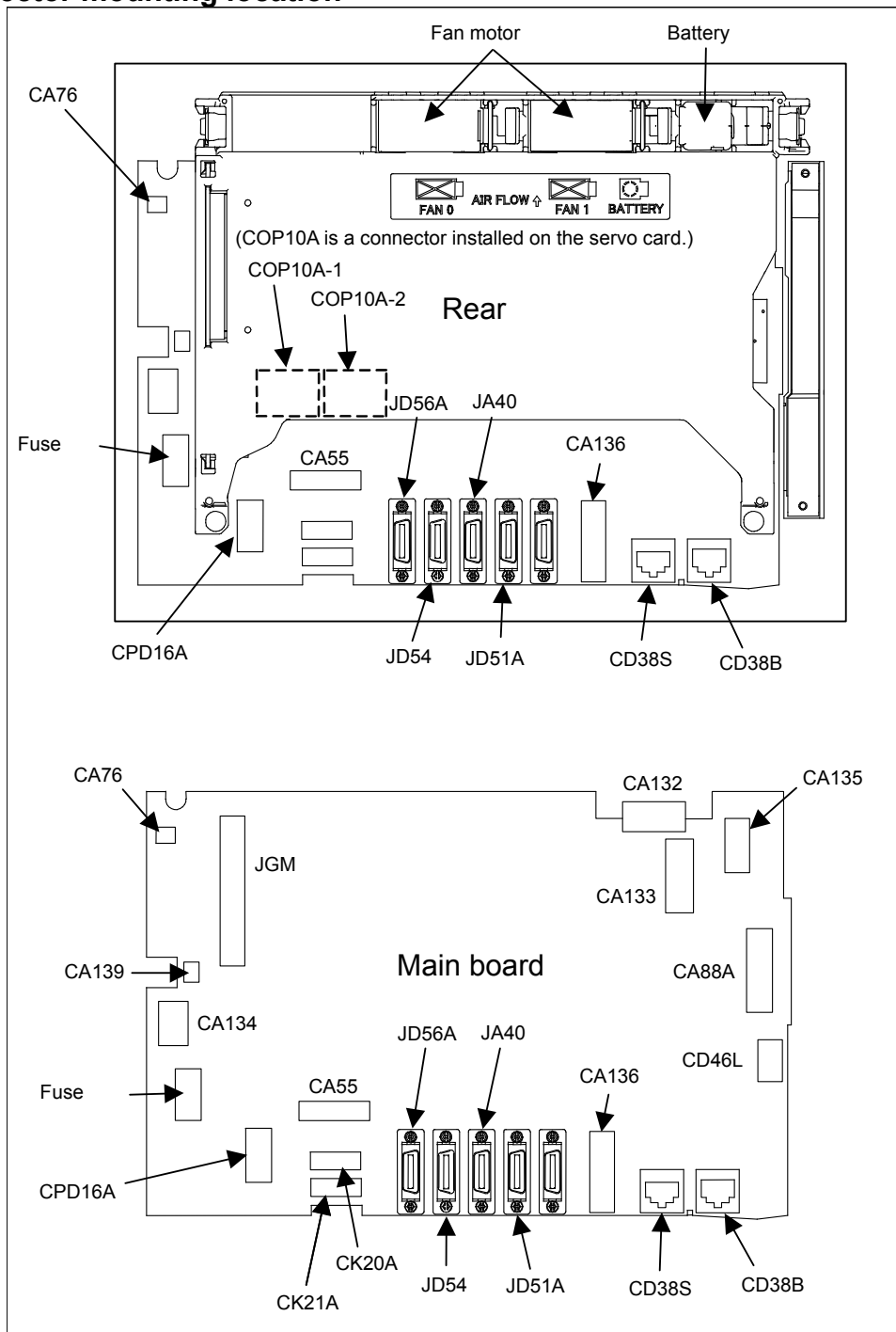

Connector number	Application
COP10A-1, COP10A-2	For FSSB interface
CA55	For MDI
JD56A	For I/O device interface (RS-232C)
JD54	For I/O device interface (RS-232C) or USB device
JA40	For high-speed skip
JD51A	For I/O Link i and I/O Link
CPD16A	For power supply
JGM	For back panel
CA133	For video signal interface (for 10.4"/12.1"LCD)
CA135	For video signal interface (for 15"LCD)

Connector number	Application
CA88A	For memory card interface
CD46L	For USB port
CK20A	For horizontal soft key
CK21A	For vertical soft key
CA132	For inverter board (for 10.4"LCD) For fan adapter board (for 12.1"/15" LCD)
CD38S	For Ethernet (Windows CE control or Embedded Ethernet)
CD38B	Ethernet (Multi-function Ethernet)
CA139	For touch panel interface
CA134	For inverter board (for 12.1"/15" LCD)
CA76	For buzzer interface
CA136	For backup unit

• Card and back panel mounting location

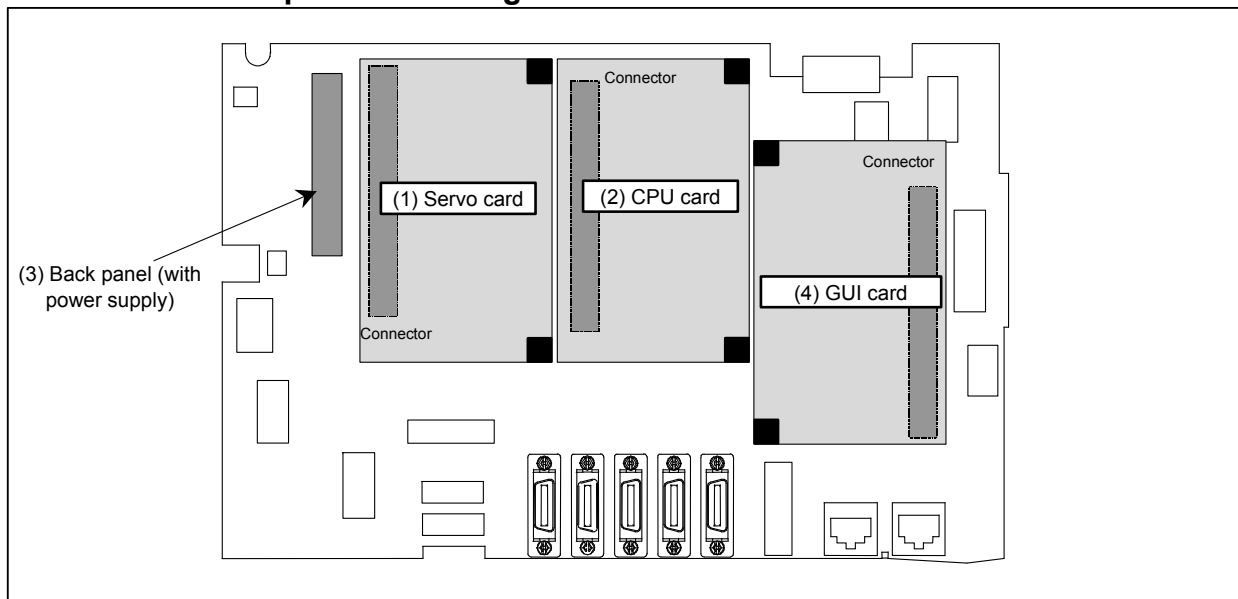

No.	Name	Specification	Remark
(1)	Servo card	See Subsection 2.4.1, "LCD-mounted Type Control Unit (8.4" LCD Unit and 10.4" LCD Unit A)".	
(2)	CPU card		
(3)	Back panel (with power supply)		
(4)	GUI card	A20B-3300-0670	
		A20B-3300-0671	



- FROM/SRAM module and compact flash card mounting location

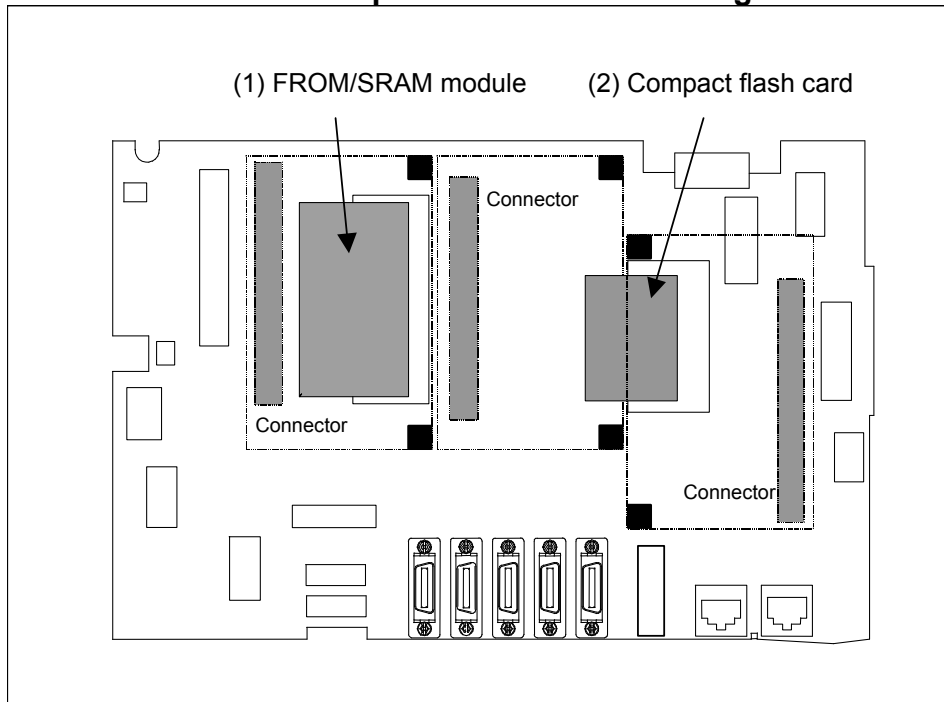

No.	Name	Specification	Remark
(1)	FROM/SRAM module	A20B-3900-0260	The FROM stores various control software programs, user software programs, and so forth. The SRAM is a battery-backed memory module.
(2)	Compact flash card	A87L-0001-0173#128MBD	Total capacity: 128MB
		A87L-0001-0173#256MBD	Total capacity: 256MB
		A87L-0001-0173#512MBD	Total capacity: 512MB
		A87L-0001-0173#001GBD	Total capacity: 1GB
		A87L-0001-0173#002GBD	Total capacity: 2GB

- Block diagram

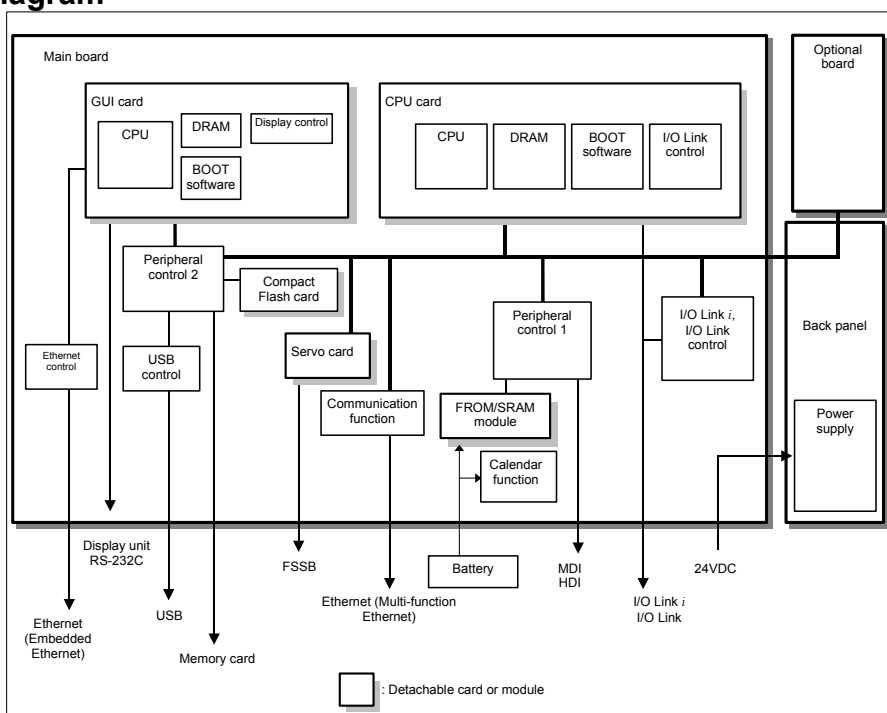

- LED display

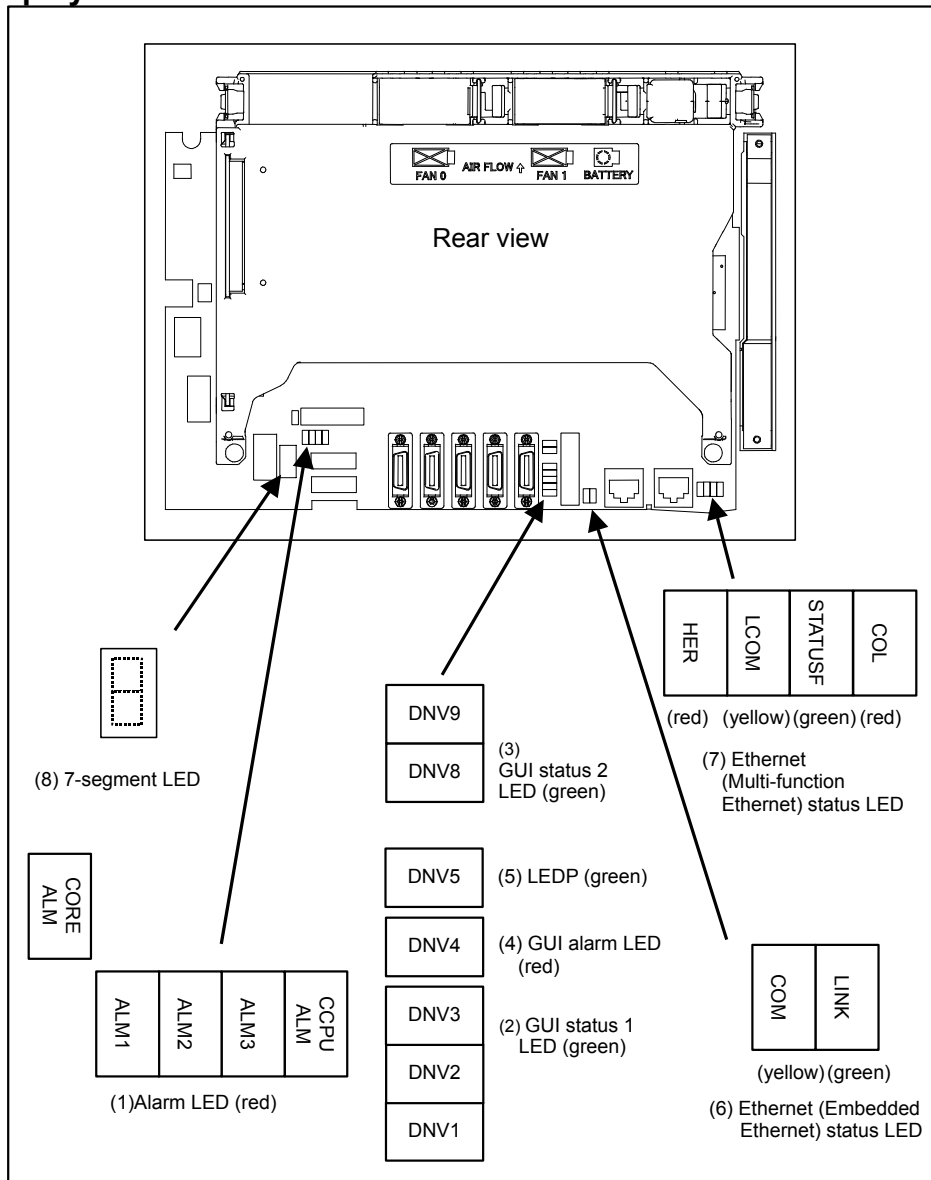

(1) Alarm LED (red LED)

CORE ALM	ALM 1	ALM 2	ALM 3	CCPU ALM	Meaning
◇	□	■	□	◇	Low battery voltage. The battery may be is running out.
◇	■	■	□	◇	Software detected an error and stopped the system.
◇	□	□	■	◇	Hardware detected a failure in the system.
◇	■	□	■	◇	An alarm was issued with the servo card on the main board.
◇	□	■	■	◇	An error was detected in the data of the SRAM on the FROM/SRAM module. The FROM/SRAM module may be faulty, the battery voltage may have dropped, or the main board may be faulty.
◇	■	■	■	◇	Abnormal power supply operation. The cause may be noise or the back panel (with power supply) failure.
◇	◇	◇	◇	■	The CPU card may be faulty.
■	◇	◇	◇	◇	Lights if there is an abnormal condition in the power supply on the main board.

■: On □: Off ◇: Don't care

(2) GUI status 1 LED (green LED)

LED			Meaning
DNV3 (STA3)	DNV2 (STA2)	DNV1 (STA1)	
<input type="checkbox"/>	<input type="checkbox"/>	<input type="checkbox"/>	State where the power is not tuned on, or state where the system was started up successfully and is running normally.
<input checked="" type="checkbox"/>	<input checked="" type="checkbox"/>	<input checked="" type="checkbox"/>	State immediately after the power is turned on. If the state remains unchanged: If "CCPUALM" is on: It is likely that the CPU card may be defective. If "CCPUALM" is off: It is likely that the main board or GUI card may be defective.
<input checked="" type="checkbox"/>	<input checked="" type="checkbox"/>	<input type="checkbox"/>	The NCBoot32 screen is active.
<input type="checkbox"/>	<input checked="" type="checkbox"/>	<input type="checkbox"/>	IPL processing is under way.

■: On   □: Off

(3) GUI status 2 LED (green LED)

LED	Meaning
DNV8 (LED2)	Indicates the operation status of the personal computer function.
DNV9 (LED1)	Indicates the operation status of the personal computer function.

■: On   □: Off

(4) GUI alarm LED (red LED)

LED	Meaning
DNV4 (RAME)	Common RAM error. The main board may be faulty.

(5) LEDP (green LED)

LED	Meaning
DNV5 (LEDP)	Turned on when power is supplied to the GUI card.

(6) Ethernet (Embedded Ethernet) status LED

LED	Meaning
LINK (green)	Turned on when a connection is made with the hub correctly.
COM (yellow)	Turned on when data is transferred.

## (7) Ethernet (Multi-function Ethernet) status LED

In the following explanations, the LED lighting states are expressed as follows:

□: Off    ■: On    ☆: Blinking    ◇: Don't care

## - LED display transition for STATUSF (power on state)

LED display	Status	Meaning
□	Power-off	
■	Immediately after power-on	Initial state entered immediately after power-on. If LED is stopped in this condition, the cause is one of the following: → The CNC communication software may not be running normally. Check whether the communication software is installed properly. → The main board may be faulty. Replace the main board.
☆	Start completion	The Multi-function Ethernet function has started normally.

## - LED display for STATUSF (during normal operation)

LED display	Status	Meaning
☆	Normal status	The Multi-function Ethernet function is operating normally.

## - LED display for LCOM

LED display	Status	Meaning
□	Not connected to hub	The board is not connected to the hub properly. The LED stays off also when the power to the hub is off. Check whether the board is connected to the hub properly.
■	Connected to hub	The board is connected to the hub.
☆	Transmission/reception in progress	Data is being transmitted or received.

## - LED display for COL

LED display	Status	Meaning
□	Normal status	The Multi-function Ethernet function is operating normally.
■ ☆	Collision occurs. (Data collision occurs.)	The LED is on or blinks at short intervals when the Ethernet communication traffic (communication amount) is high or ambient noise is high.

## - LED display for HER

LED display	Status	Meaning
□	Normal status	The Multi-function Ethernet function is operating normally.
■	Error detected in the Ethernet circuit on the main board	The cause may be the faulty main board or a malfunction due to noise.
☆	Error detected in the software	

## (8) 7-segment LED

See Appendix E, "LED Display".

**Inverter board and fan adapter board specification**

	<b>Name</b>	<b>Specification</b>	<b>Remark</b>
Inverter board	For 10.4" LCD (working also as fan adapter board)	A20B-8200-0662	
	For 12.1" LCD	A14L-0143-0003	
	For 15" LCD	A14L-0168-0001	
Fan adapter board	For 10.4" LCD (working also as fan adapter board)	Works also as the inverter board mentioned above.	
	For 12.1" LCD	A20B-8200-0669	
	For 15" LCD		
Main board-to-inverter board connection cable	For 12.1" LCD	A660-4042-T075#L90R00	
	For 15" LCD	A660-4042-T076#L75R00	

**- Details of the inverter board**

(1) For control unit with 10.4" LCD

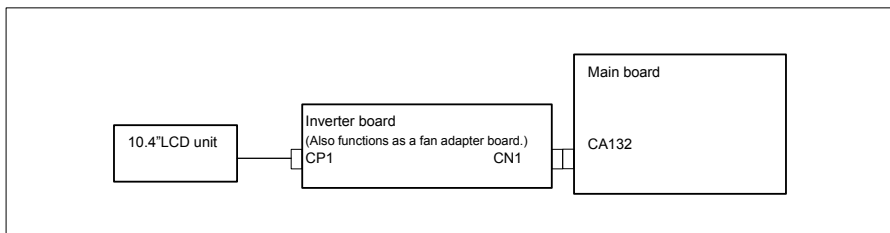

(2) For control unit with 12.1" LCD

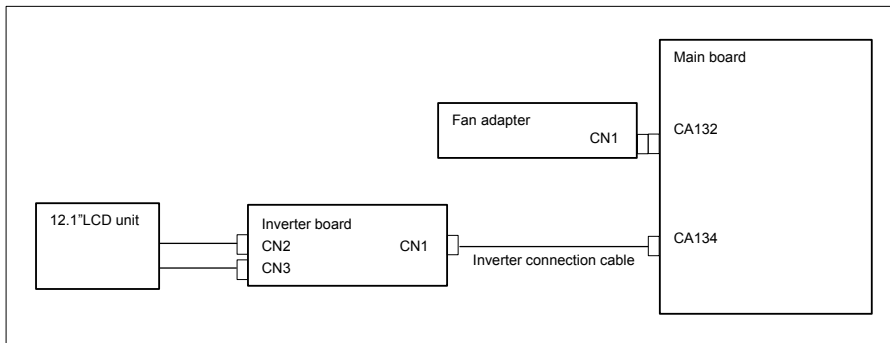

(3) For control unit with 15" LCD

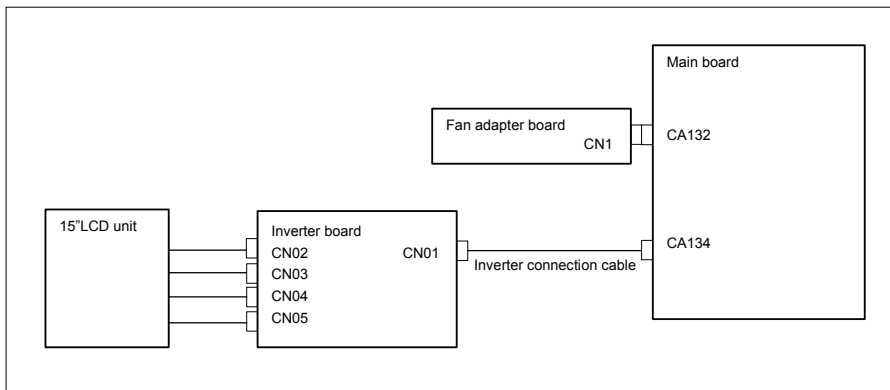

- **Locations of the inverter board and fan adapter board**

(1) For control unit with 10.4" LCD

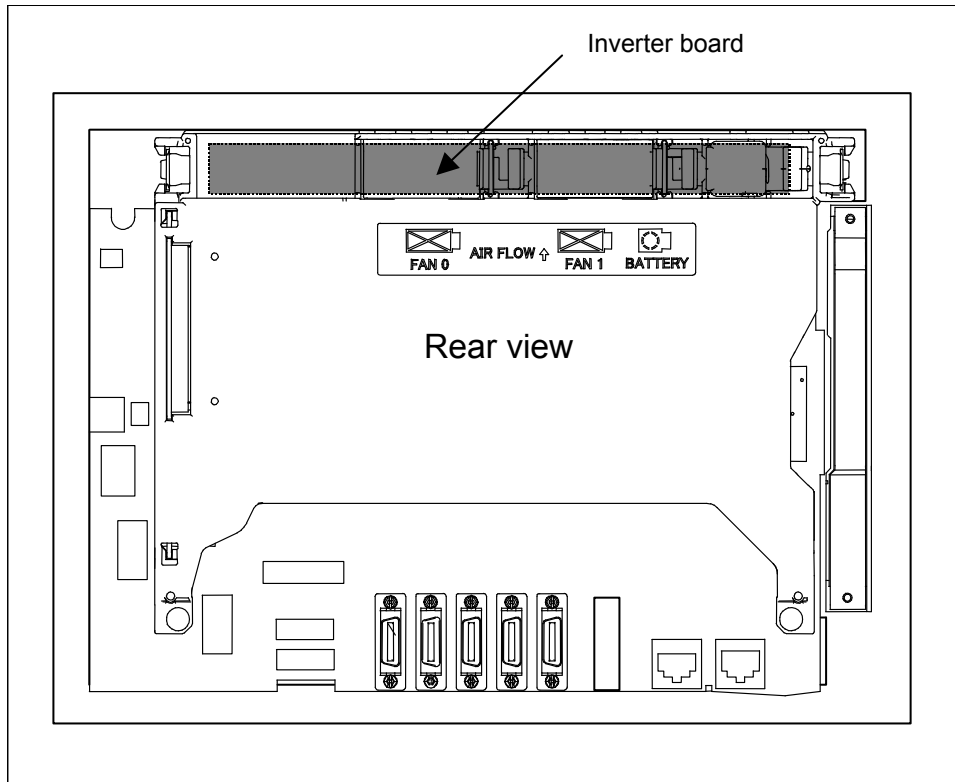

(2) For control unit with 12.1" LCD

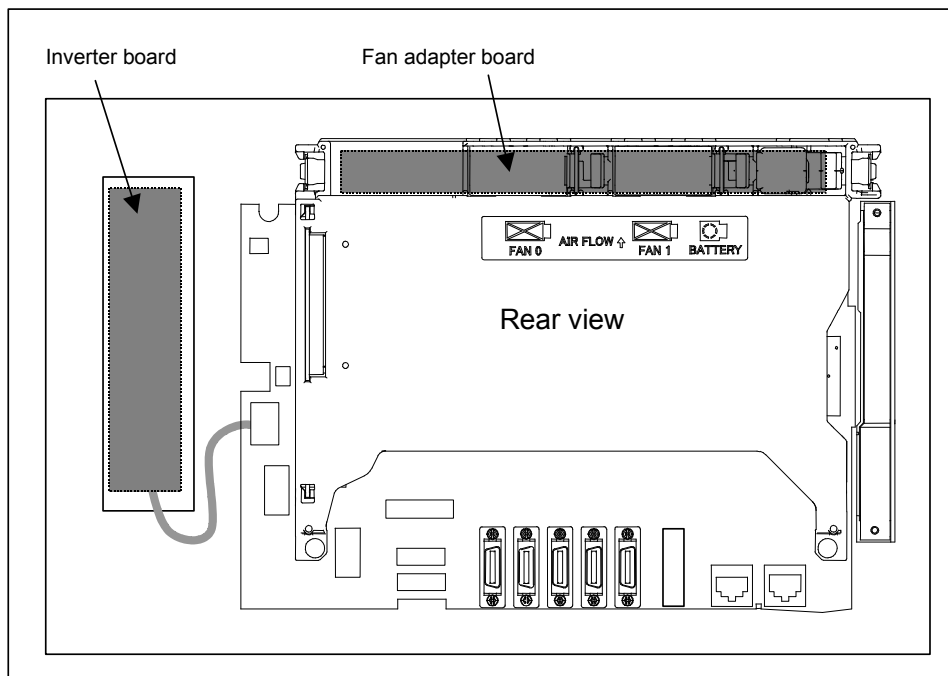

(3) For control unit with 15" LCD

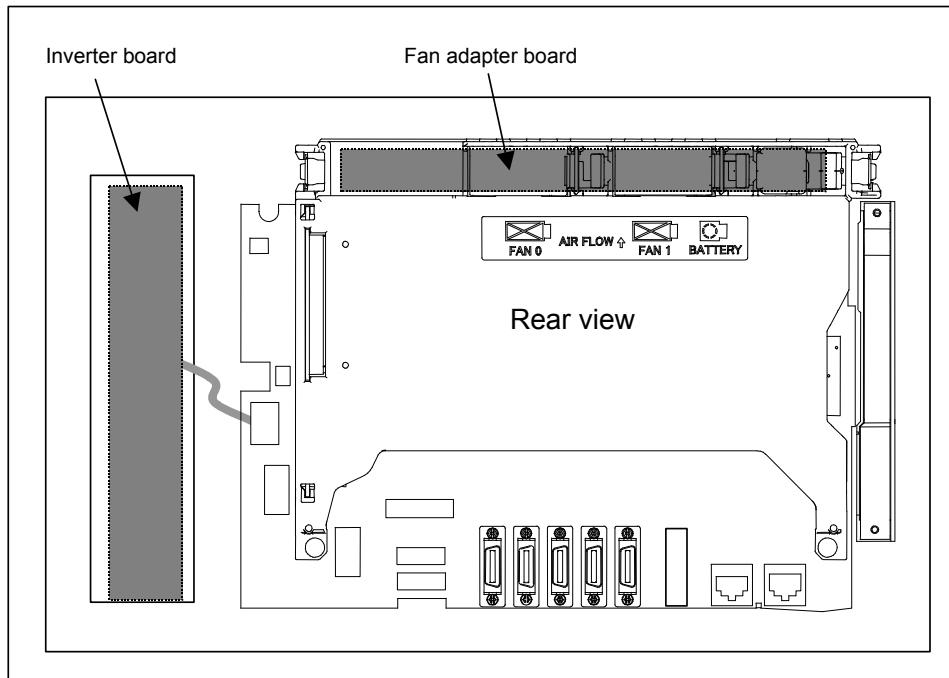

**- Backup unit specification**

Name	Specification	Remark
Backup unit board	A20B-2100-0820	
Backup unit cable	A02B-0323-K801	

**NOTE**

Some configurations contain no backup unit.

**- Connector mounting location**

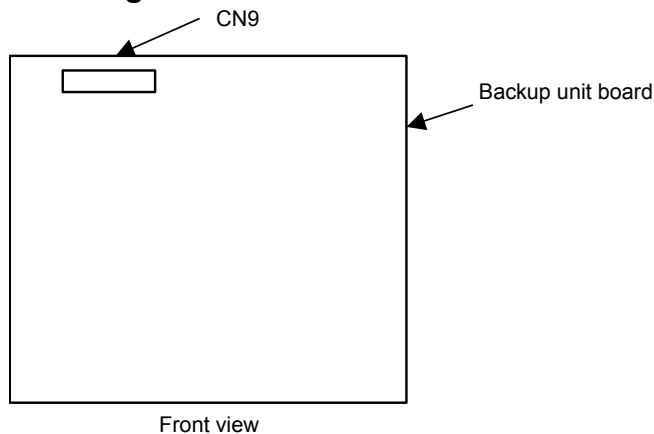

Connector name	Function
CN9	Supplies backup power.

**⚠ WARNING**

When the LED (LEDP) on the main board lights, do not touch any component in the basic and backup units. The personal computer function with Windows® CE remain active for up to 12 seconds after the main power supply is turned off.

## **2.5 HARDWARE OF STAND-ALONE TYPE CONTROL UNIT**

---

### **2.5.1 Stand-alone Type Control Unit**

---

**- Main board specification**

<b>Name</b>	<b>Specification</b>	<b>Remark</b>
Main board	A16B-3200-0710	
	A16B-3200-0711	



- **Mounting positions of connectors, LEDs, etc.**

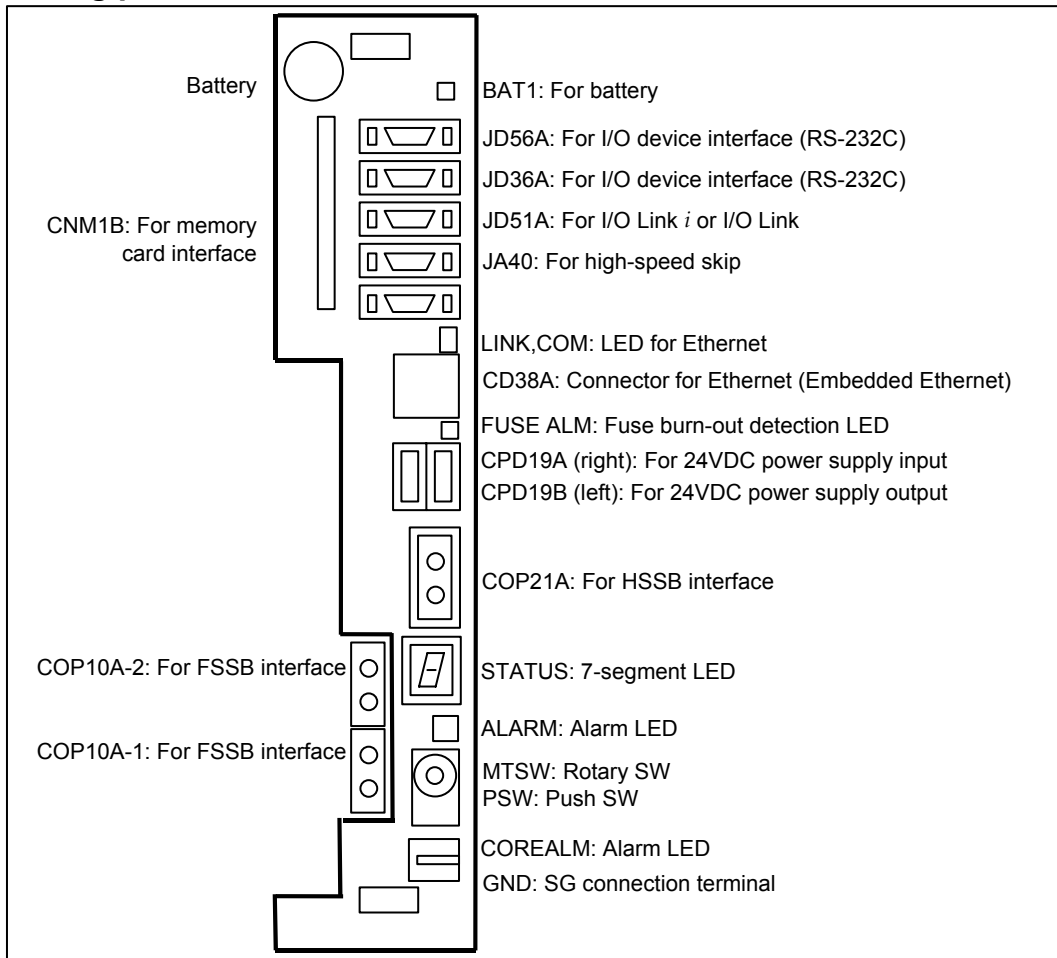

**STATUS 7-segment LED**

This LED indicates the state of the control unit. This LED is used also for setting and maintenance using the rotary switch MTSW and the push switch PSW.

**MTSW rotary switch**

This rotary switch is used for setting and maintenance operations, in combination with the STATUS 7-segment LED and the PSW push switch.

**PSW push switch:**

This push switch is used for setting and maintenance operations, in combination with the STATUS 7-segment LED and the MTSW rotary switch.

- Mounting positions of cards, power supply unit, and FROM/SRAM module

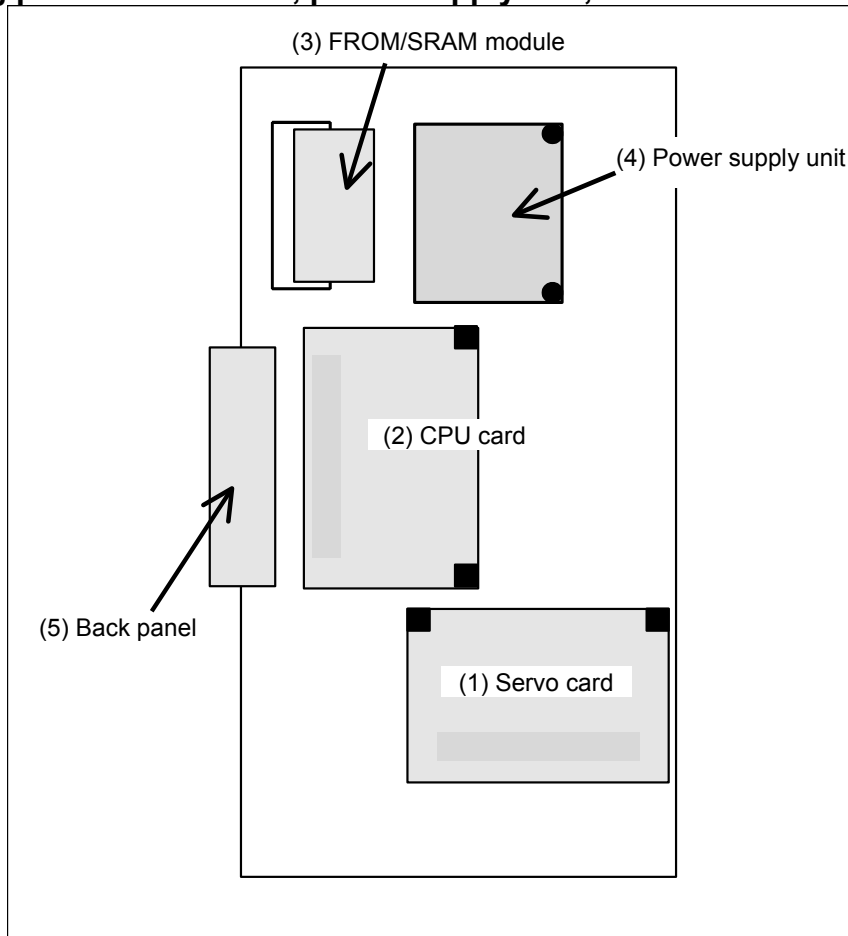

No.	Name	Specification	Remark
(1)	Servo card	See Subsection 2.4.1, "LCD-mounted Type Control Unit (8.4" LCD Unit and 10.4" LCD Unit A)".	
(2)	CPU card		
(3)	FROM/SRAM module	A20B-3900-0250	FROM stores various control software products. The SRAM is a battery-backed memory module.
		A20B-3900-0251	
		A20B-3900-0252	
		A20B-3900-0260	
(4)	Power supply unit	A20B-8101-0011	
(5)	Back panel	A20B-2003-0580	
		A20B-2003-0650	

- Block diagram

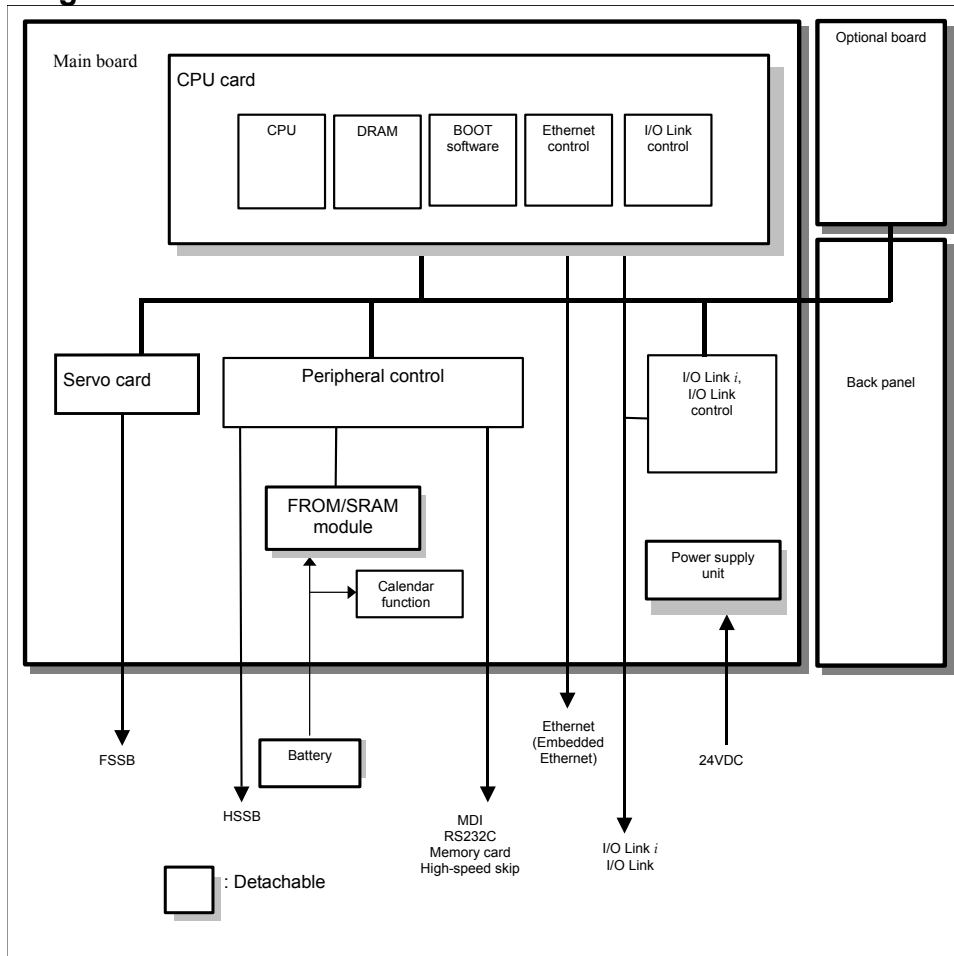



## (3) 7-segment LED

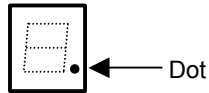

LED	Meaning
Dot	Turned on when the display unit is not connected to connector COP21A. If this LED is turned on when the display unit is connected, it is probable that the optical fiber cable is broken, the display unit is not powered on, or the display unit is faulty.

See Appendix E “LED Display” for others.

## 2.5.2 Display Unit for Stand-alone Type Control Unit

### 2.5.2.1 Display Unit (10.4” LCD unit A)

#### - Unit specification

Name	Specification	Remark
10.4” LCD unit A	A02B-0323-C074	
10.4” LCD unit A (with a protection cover)	A02B-0323-C075	
10.4” LCD unit A (with a touch panel)	A02B-0323-C084	
10.4” LCD unit A (with a touch panel and protection cover)	A02B-0323-C085	
1st 10.4” LCD unit A for two display unit	A02B-0323-C072	
1st 10.4” LCD unit A for two display unit (with a protection cover)	A02B-0323-C076	
2nd 10.4” LCD unit A for two display unit	A02B-0323-C073	
2nd 10.4” LCD unit A for two display unit (with a protection cover)	A02B-0323-C077	

#### - Prited circuit board for display unit

Name	Specification	Remark
Display control board	A20B-8200-0760	
	A20B-8200-0761	1st unit for two display unit
	A20B-8200-0762	2nd unit for two display unit
Inverter board	A20B-8200-0662	
Touch panel control board	A20B-8002-0312	

#### - Two display unit cable specification

Name	Specification	Remark
Interconnection cable for video signal	30m	A02B-0303-K843
	20m	A02B-0303-K840
	10m	A02B-0303-K841
	5m	A02B-0303-K842
Interconnection cable for MDI signal	30m	A02B-0303-K848
	20m	A02B-0303-K845
	10m	A02B-0303-K846
	5m	A02B-0303-K847

**Connector mounting location**

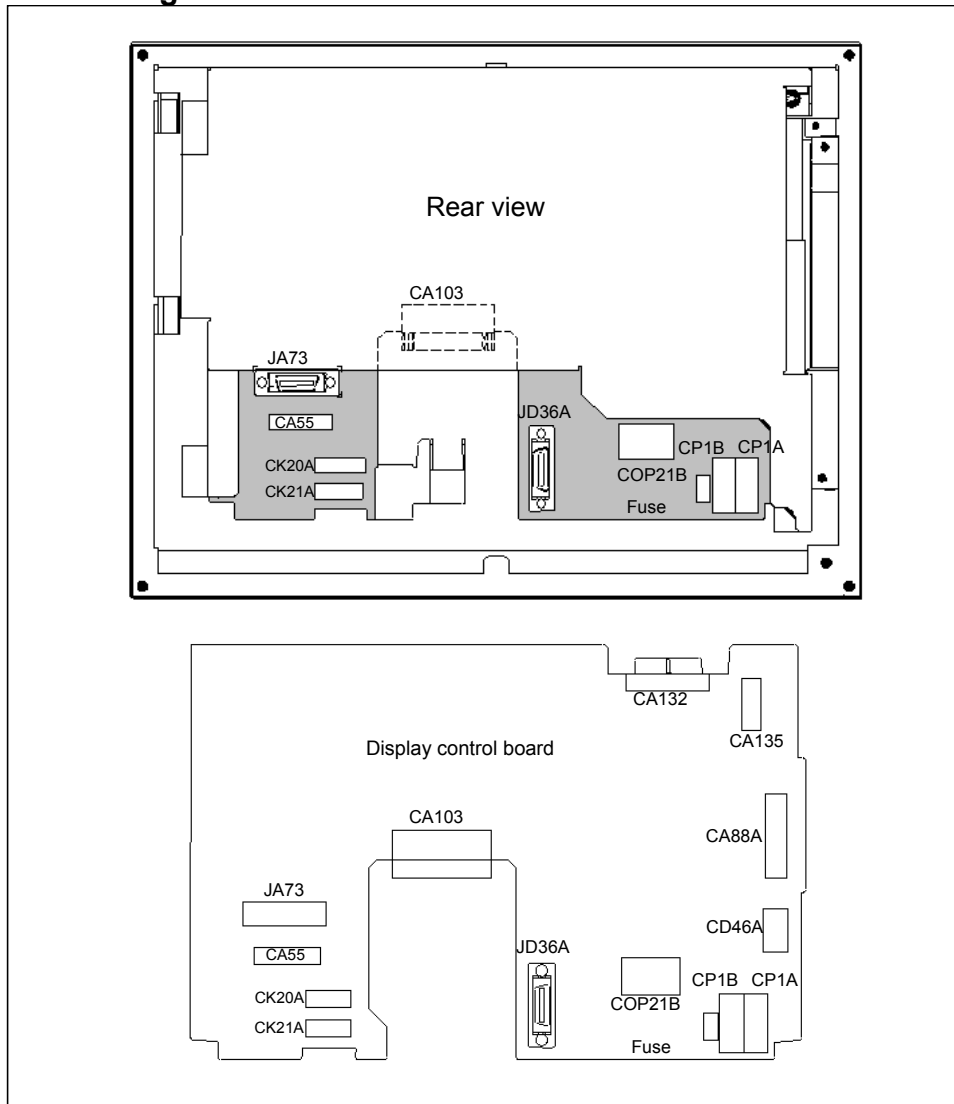

Connector number	Application
CA55	For MDI
JD36A	For touch panel interface
CP1A	For 24VDC power input
CP1B	For 24VDC power output
CA79A	For video signal interface
CA88A	For memory card interface
CD46A	For USB port
CA103	For Interconnection cable for video signal interface (for connecting two display units)
JA73	For Interconnection cable for MDI signal interface (for connecting two display units)
CK20A	For horizontal soft key
CK21A	For vertical soft key
CA87A	For inverter board
COP21B	For HSSB interface

**LED display**

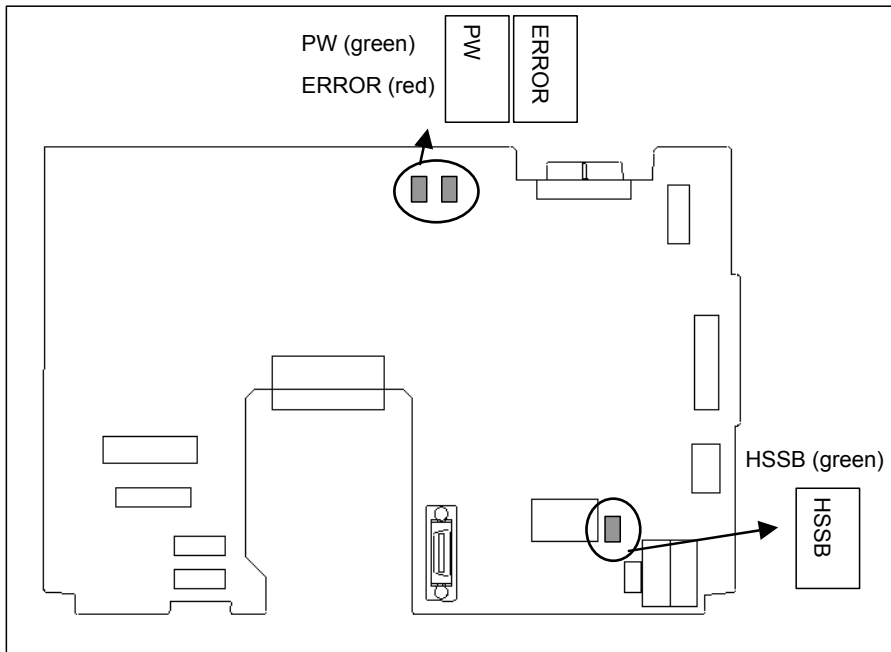

LED	Meaning
HSSB (green LED)	Lights when this board is normally connected to the control unit and communication is enabled.
PW (green LED)	Lights the power is normally turned on.
ERROR (red LED)	Lights if the hardware detects a failure in this display unit. It is likely that the display control board may be defective.

If a failure is detected on the control unit side, ERROR (red LED) does not light because of a communication failure such as a broken HSSB cable. In this case, the screen display that appears when the failure occurs will keep blinking.

**Configuration of the inverter**

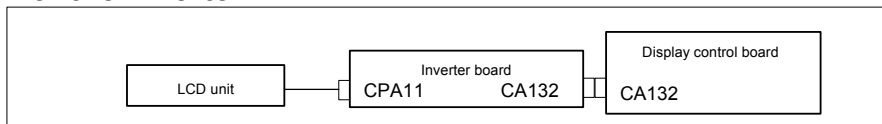

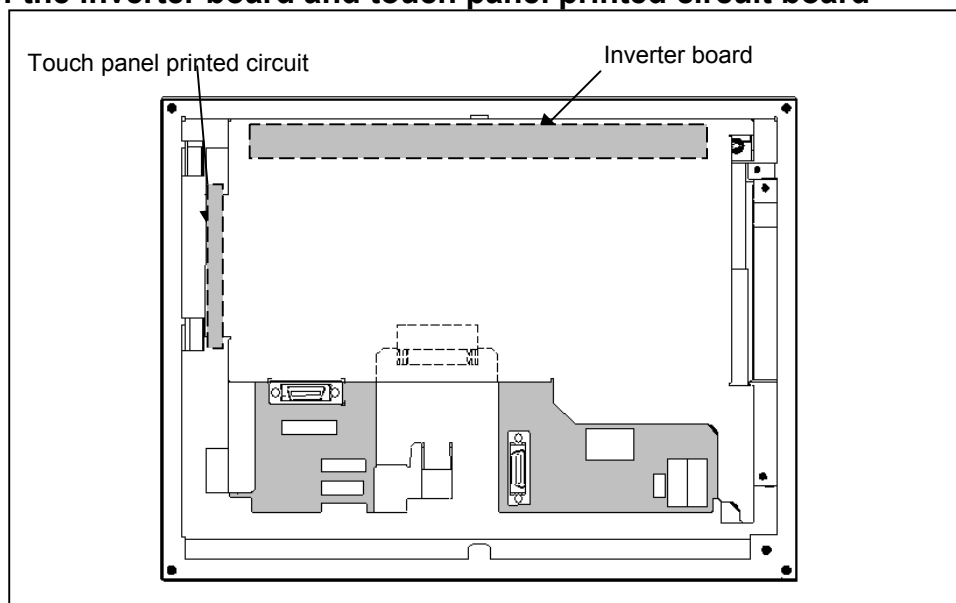
**Positions of the inverter board and touch panel printed circuit board****2.5.2.2 Display unit (10.4" LCD unit B and 15" LCD unit)****- Unit specification**

Name	Specification	Remark
10.4" LCD unit B	A02B-0323-C078	
10.4" LCD unit B (with a touch panel)	A02B-0323-C079	
10.4" LCD unit B (with a protection cover)	A02B-0323-C088	
10.4" LCD unit B (with a touch panel and protection cover)	A02B-0323-C089	
15" LCD unit	A02B-0323-C091	
15" LCD unit (with a touch panel)	A02B-0323-C092	
15" LCD unit (with a protection cover)	A02B-0323-C095	
15" LCD unit (with a touch panel and protection cover)	A02B-0323-C096	

**- Display control board specification**

Name	Specification	Remark
10.4" LCD unit B	A20B-8200-0746	
15" LCD unit	A20B-8200-0742	



- Connector mounting location

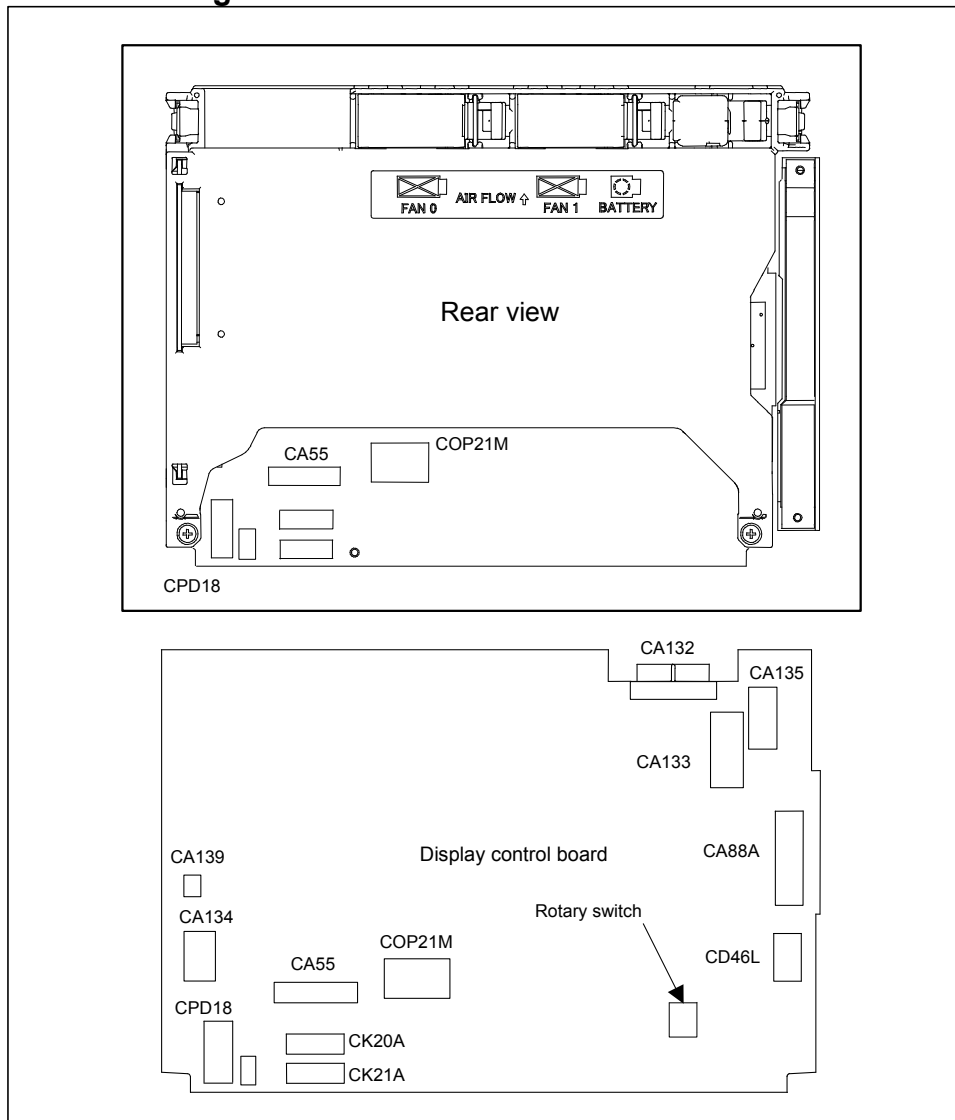

Connector number	Application
CA55	For MDI
CPD18	For power supply
CA133	For video signal interface (for 10.4"LCD)
CA135	For video signal interface (for 15"LCD)
CA88A	For memory card interface
CD46L	For USB port
CK20A	For horizontal soft key
CK21A	For vertical soft key
CA132	For inverter board (for 10.4"LCD) For fan adapter board (for 15"LCD)
COP21M	For HSSB interface
CA139	For touch panel interface
CA134	For inverter board (for 15"LCD)

- Mounting positions of the GUI card, power supply unit, and compact flash card

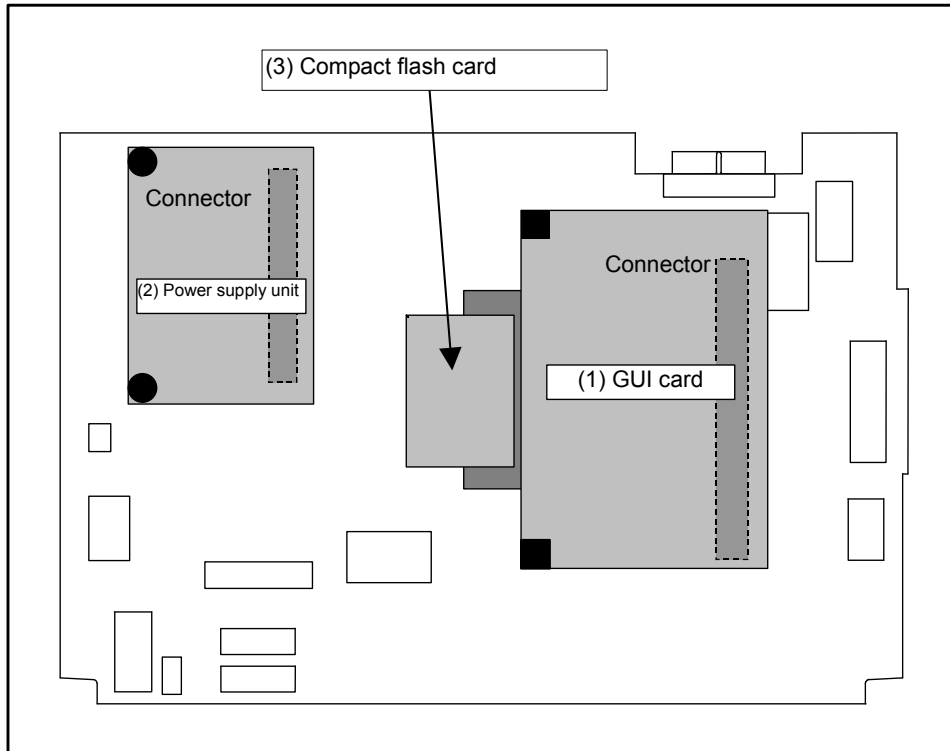

No.	Name	Specification	Remark
(1)	GUI card	A20B-3300-0670	
(2)	Power supply unit	A20B-8101-0011	
(3)	Compact flash card	A02B-0323-C990#A	Including software

- LED display

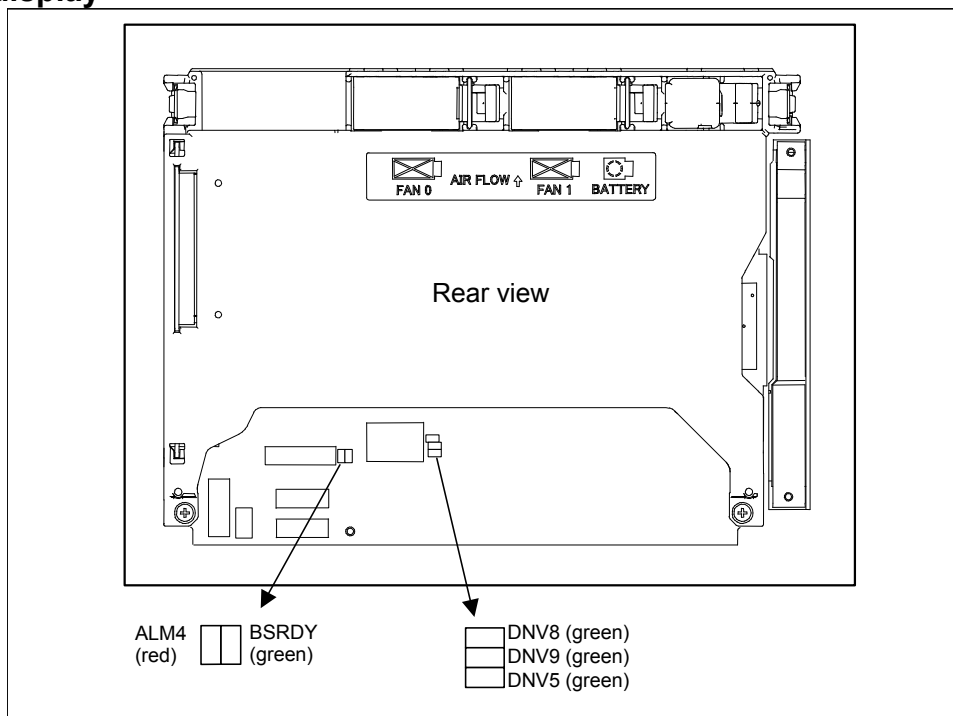

## (1) HSSB status LED

LED	Meaning
BSRDY (green)	Lights when this board is normally connected to the control unit and communication is enabled.
ALM2 (RAME · red)	Indicates a common RAM error. It is likely that the display control board may be defective.

## (2) Others (green LED)

LED	Meaning
DNV5 (LEDP)	Turned on when power is supplied to the display unit.
DNV8 (LED2)	Indicates the operation status of the screen display function.
DNV9 (LED1)	Indicates the operation status of the screen display function.

**- Inverter board and fan adapter board**

	Name	Specification	Remark
Inverter board	For 10.4" LCD (working also as fan adapter board)	A20B-8200-0662	
	For 15" LCD	A14L-0168-0001	
Fan adapter board	For 10.4" LCD (working also as fan adapter board)	Works also as the inverter board mentioned above.	
	For 15" LCD	A20B-8200-0669	
Connection cable between the display control board and the inverter board	For 15" LCD	A660-4042-T076#L75R00	

**- Details of the inverter board**

(1) For display unit with 10.4" LCD

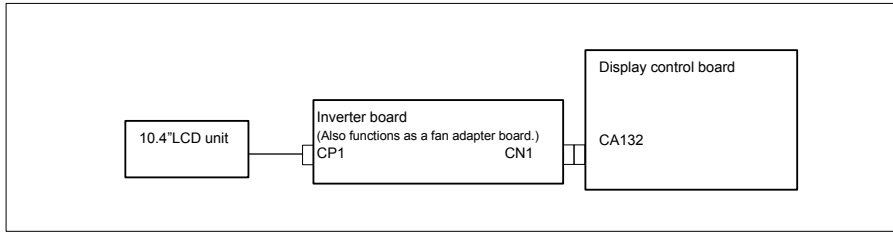

(2) For display unit with 15" LCD

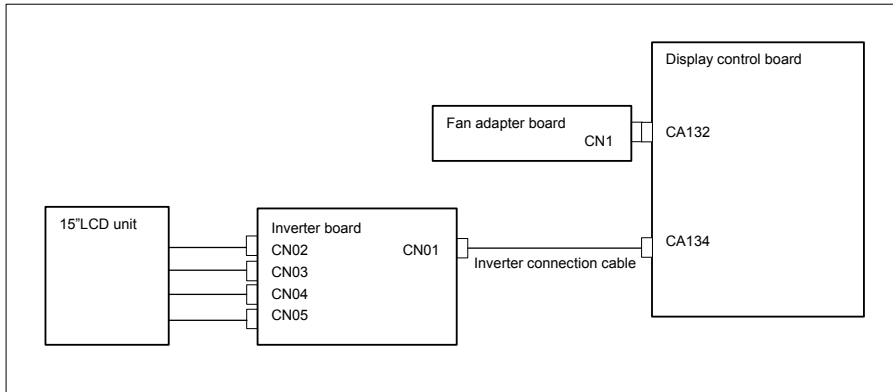

**- Locations of the inverter board and fan adapter board**

(1) For display unit with 10.4" LCD

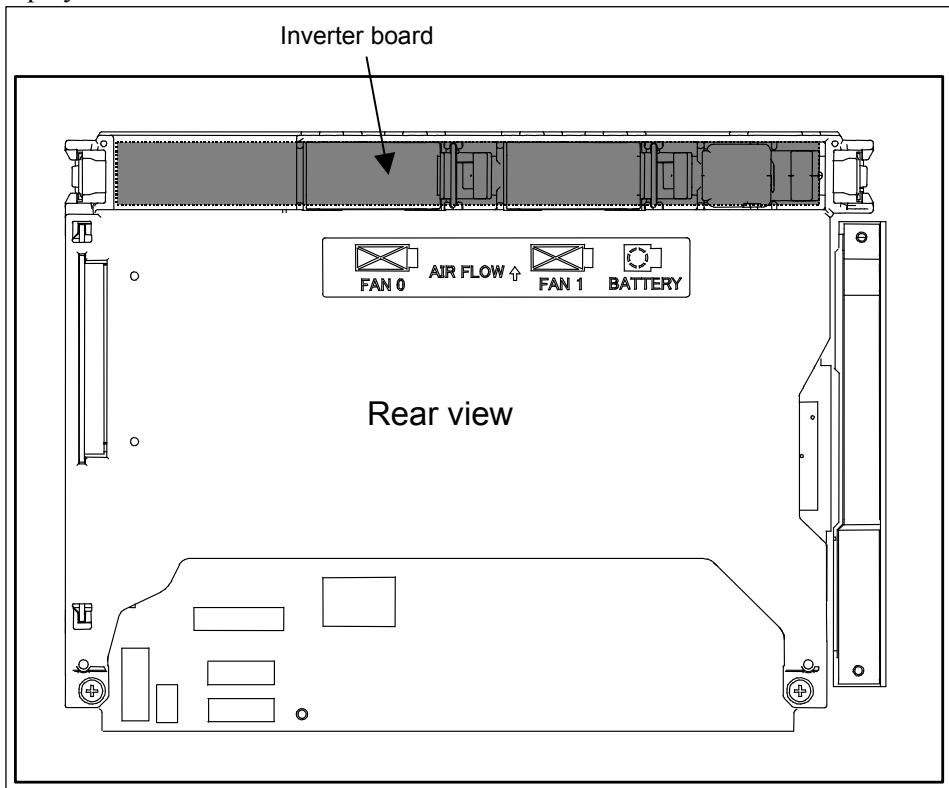

(2) For display unit with 15" LCD

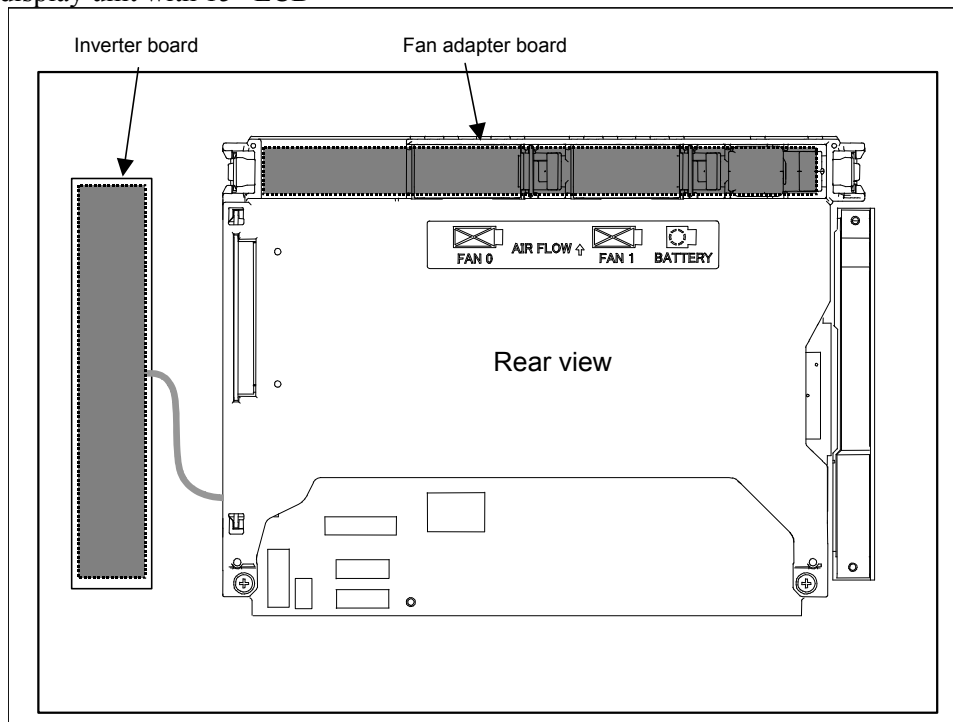

**- Connecting the display unit to the control unit**

For the display unit, place the rotary switch to 0 (initial setting).

Connection mode	Rotary switch setting
Default	0
Reserve	1 to F

**NOTE**

Do not set the rotary switch to the Reserve position.

**2.5.2.3 Display unit for automotive manufacture**

**- Unit specification**

Name	Specification	Remark
Display unit for automotive manufacture	A13B-0201-B201	
Display unit for automotive manufacture (with a touch panel)	A13B-0201-B202	
Display unit for automotive manufacture (with a protection cover)	A13B-0201-B203	
Display unit for automotive manufacture (with a touch panel and protection cover)	A13B-0201-B204	
Display unit for automotive manufacture (with I/O Link)	A13B-0201-B211	
Display unit for automotive manufacture (with a touch panel and I/O Link)	A13B-0201-B212	
Display unit for automotive manufacture (with I/O Link and protection cover)	A13B-0201-B213	
Display unit for automotive manufacture (with a touch panel, I/O Link, and protection cover)	A13B-0201-B214	

**- Display control board**

Name	Specification	Remark
Display control board	A20B-8200-0745	

- Display control board mounting location

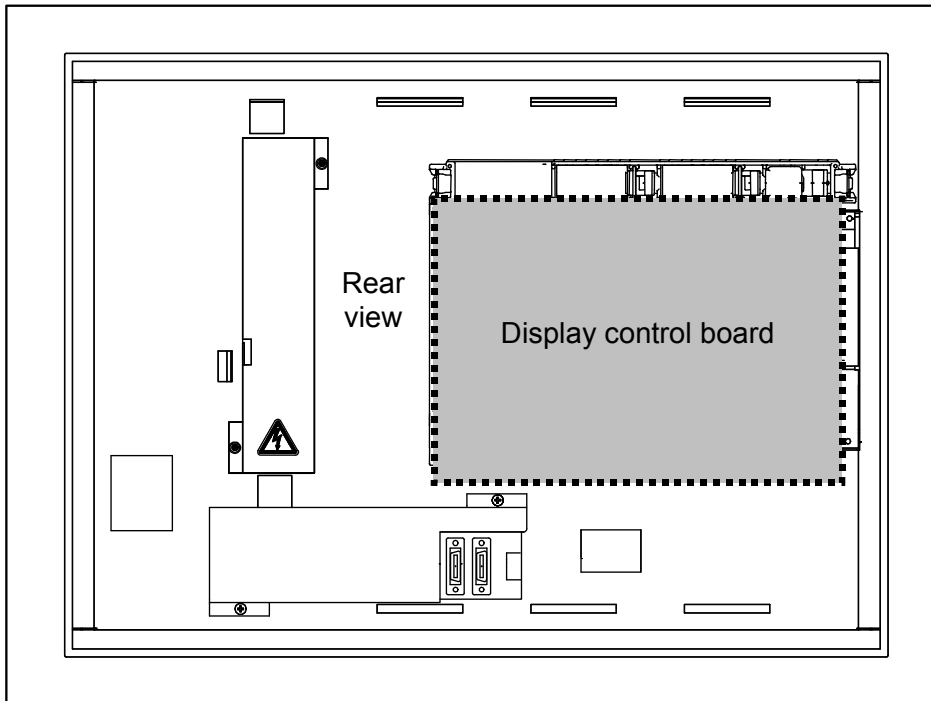

- Connector mounting location

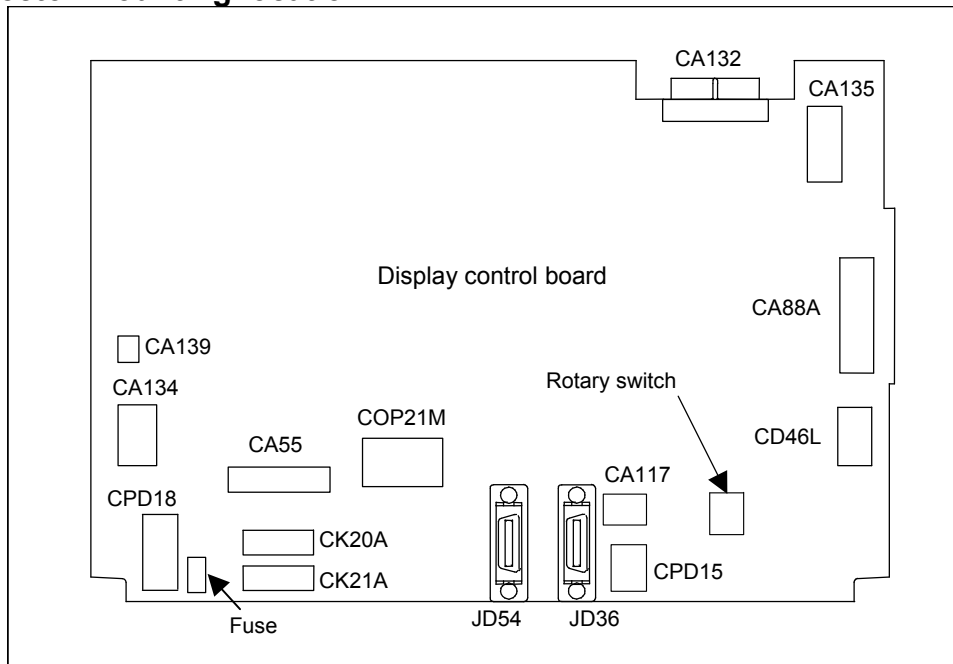

Connector number	Application
CA55	For MDI
CA132	For fan adapter board
CA88A	For memory card interface
CA139	For touch panel interface
CA135	For video signal interface
CD46L	For USB port
CK20A	For horizontal soft key
CK21A	For vertical soft key

Connector number	Application
COP21M	For HSSB interface
CA134	For inverter board
CPD18	For power supply
JD36	For I/O device interface (RS-232C)
JD54	For I/O device interface (RS-232C) or USB device
CPD15	For DC power interface of the I/O Link adapter board
CA117	For LED interface

- Mounting positions of the GUI card, power supply unit, and compact flash card

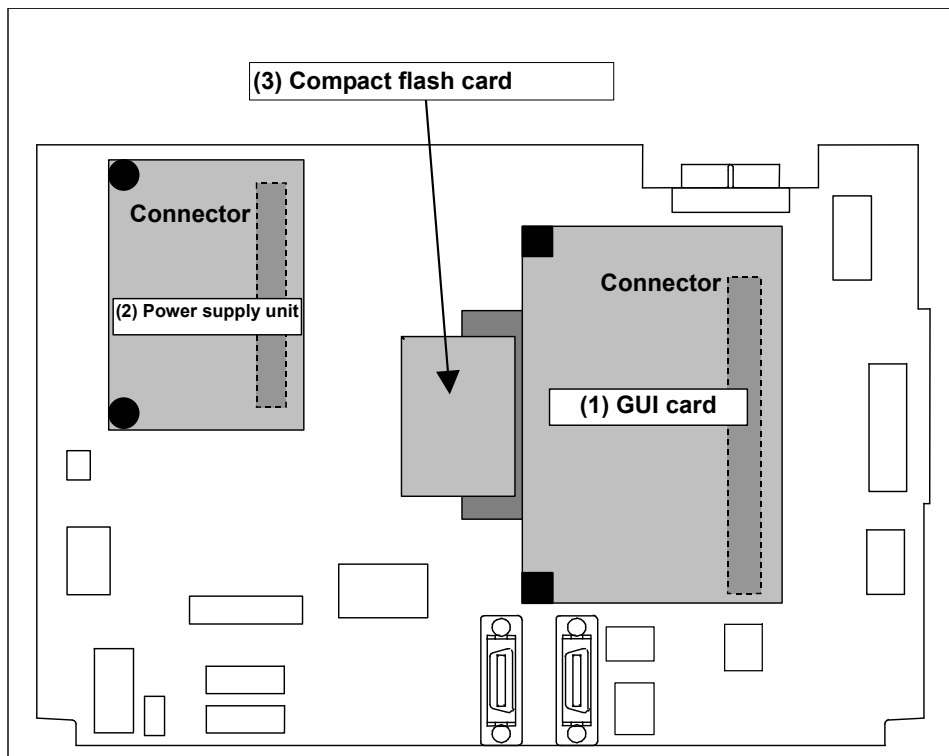

No.	Name	Specification	Remark
(1)	GUI card	A20B-3300-0670	
(2)	Power supply unit	A20B-8101-0011	
(3)	Compact flash card	A02B-0323-C990#B	Including software

- **Block diagram**

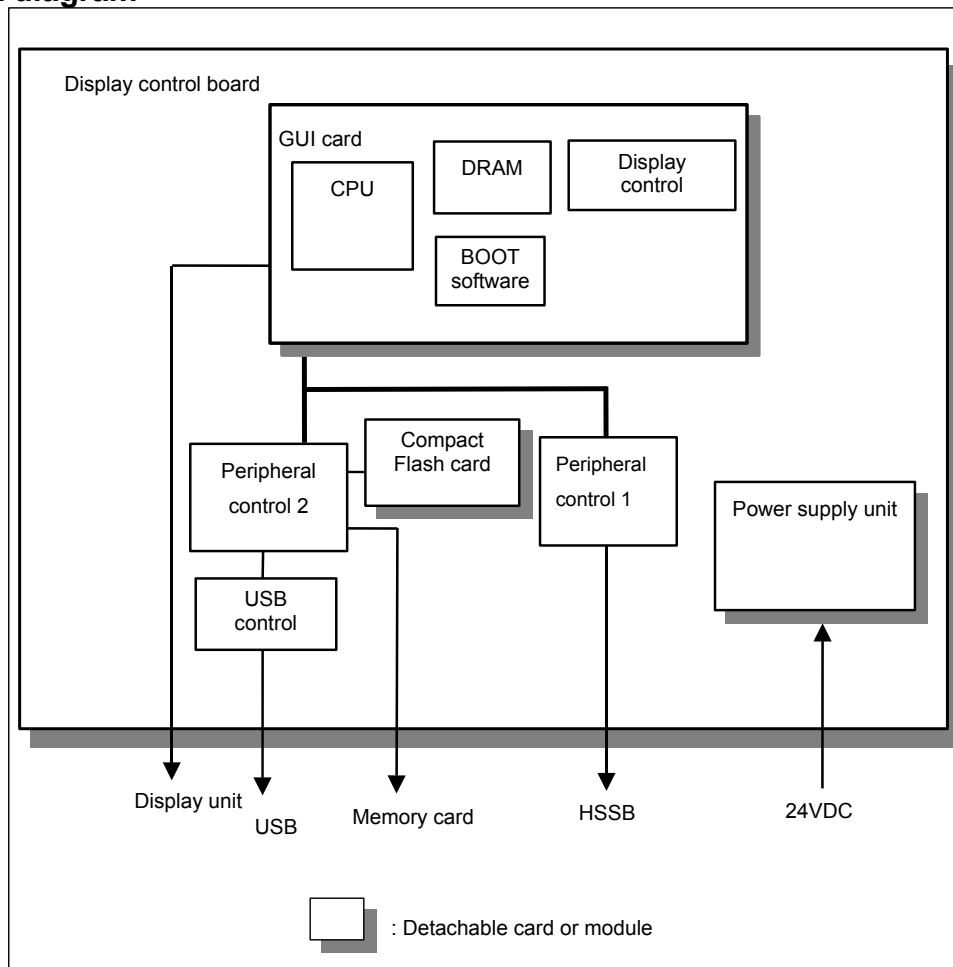



- LED display

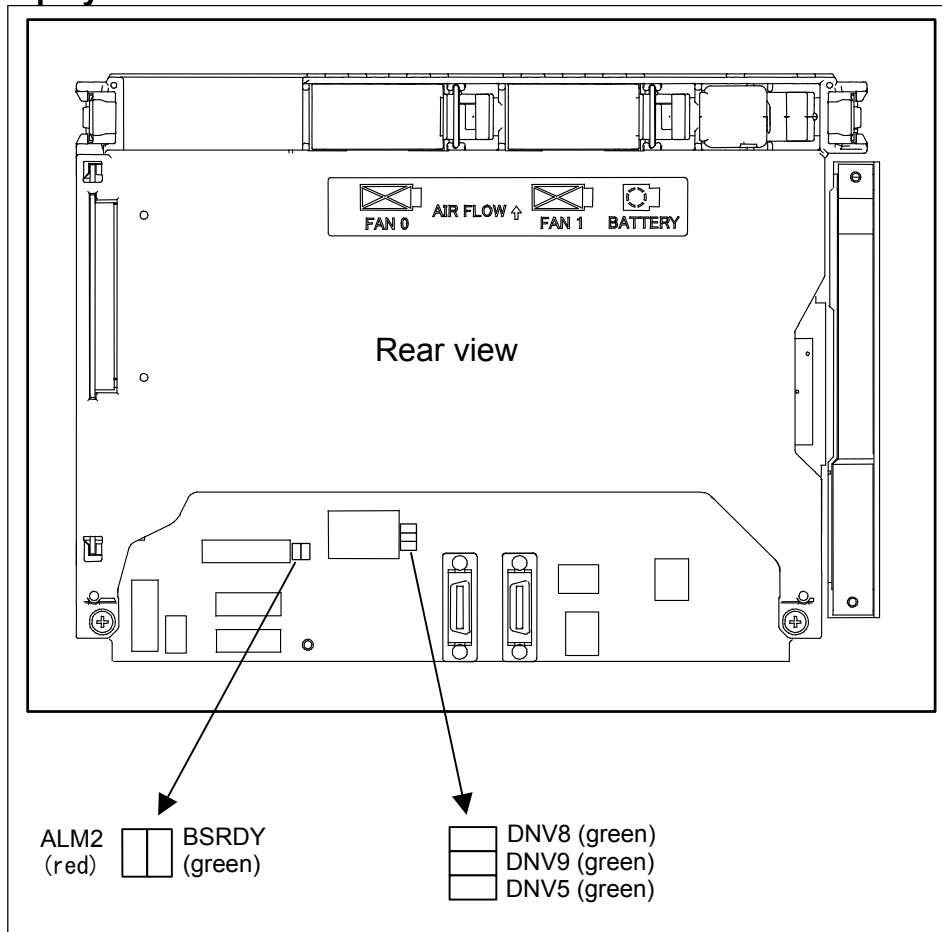

(1) HSSB status LED

LED	Meaning
BSRDY (green)	Lights when this board is normally connected to the control unit and communication is enabled.
ALM2 (RAME · red)	Indicates a common RAM error. It is likely that the display control board may be defective.

(2) Others (green LED)

LED	Meaning
DNV5 (LEDP)	Turned on when power is supplied to the display unit.
DNV8 (LED2)	Indicates the operation status of the screen display function.
DNV9 (LED1)	Indicates the operation status of the screen display function.

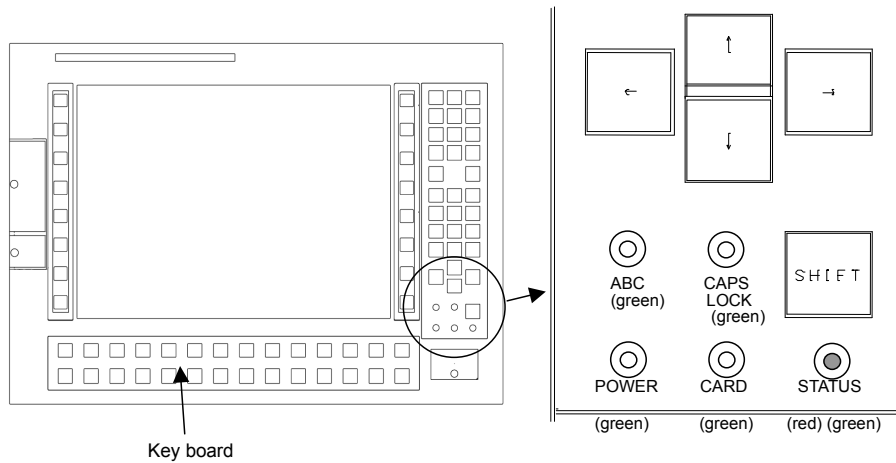

(4) LED on MDI

LED	Meaning
ABC (green)	Lights when the function key is in the alphabet input mode.
CAPS LOCK (green)	Lights when CAPS LOCK is enabled.
POWER (green)	Lights when the unit is powered on.
CARD (green)	Lights when data is being written to or read from the built-in memory card.
STATUS (green / red)	Lights in red during power-on or in green when after startup. Normally, this LED lights in green, but lights in red if a hardware alarm such as overheating, fan stop, or bus disconnection occurs.

- Inverter board and fan adapter board

Name	Specification	Remark
Inverter board	A14L-0168-0001	
Fan adapter board	A20B-8200-0669	
Connection cable between the display control board and the inverter board	A660-4042-T076#L75R00	

- Details of the inverter board

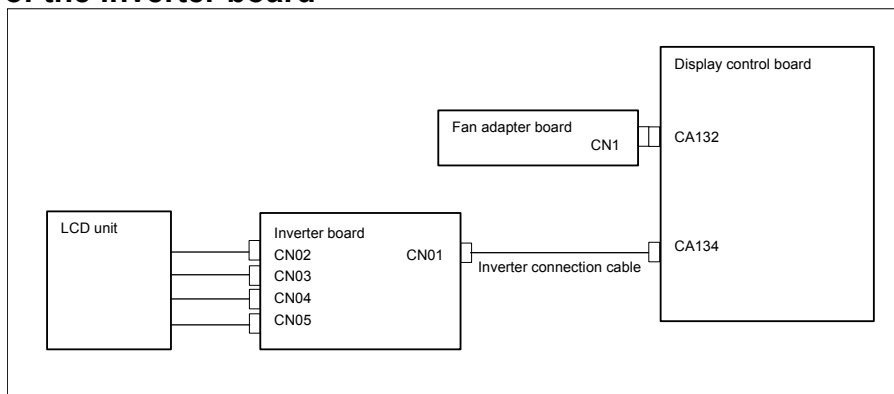

- **Locations of the inverter board and fan adapter board**

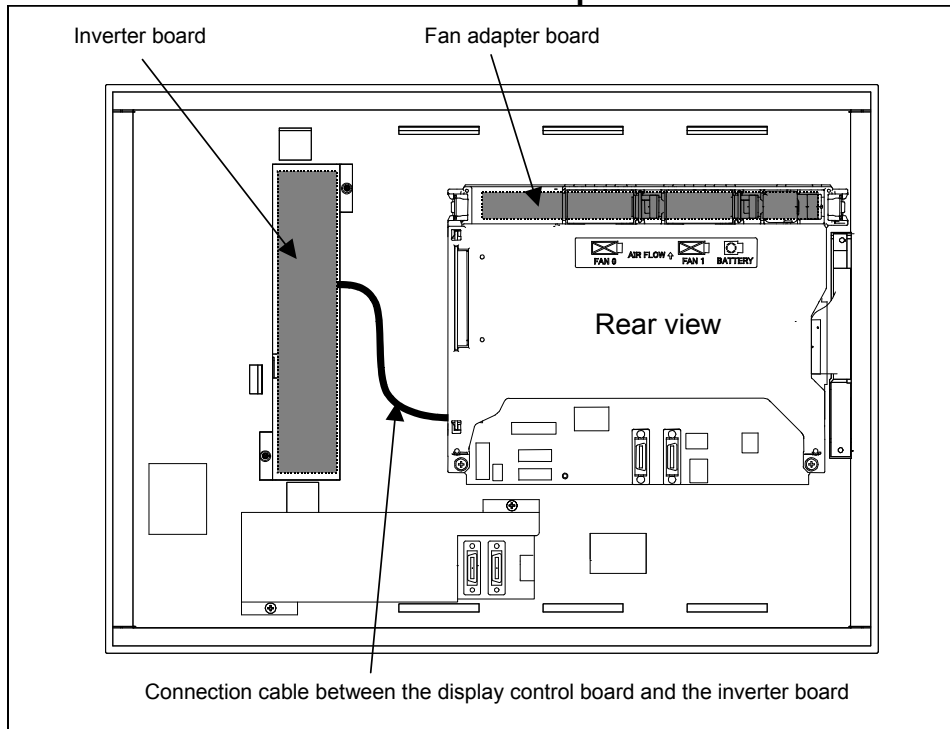

- **Connecting the display unit to the control unit**

For the display unit, place the rotary switch to 0 (initial setting).

Connection mode	Rotary switch setting
Default	0
Reserve	1 to F

**NOTE**

Do not set the rotary switch to the Reserve position.

**I/O Link adapter board (Unit specification: A13B-0201-B211, -B212, -B213, and -B214 only)**

Name	Specification	Remark
I/O Link adapter board	A20B-8002-0500	

### - I/O Link adapter board mounting location

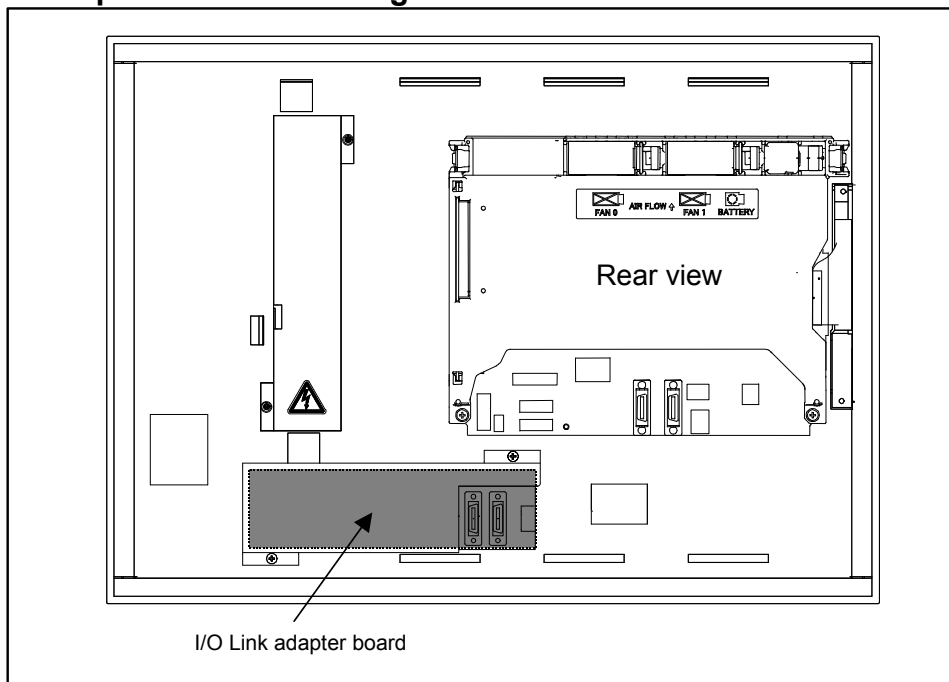

### - Details of the I/O Link adapter board

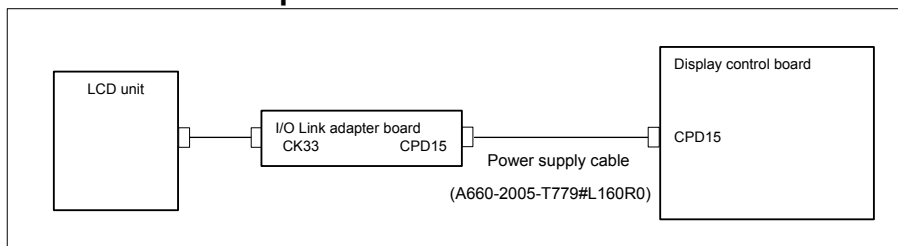

## Use of NCBOOT32

### 1. Purpose

NCBOOT32 perform the following operations.

- Displays the BOOT screen.  
On this screen, it is possible to perform CNC maintenance work such as installation or backup of the CNC system program or saving, restoration, or clearing of SRAM.
- Displays the IPL screen.
- Displays the CNC alarm screen.
- Monitors the state of communication with the CNC and makes reconnection during occurrence of an error.

### 2. Startup

Using the rotary switch on the display control board in the display unit for automobile manufacturers can change the startup sequence.

To start NCBOOT32 or return to the normal operation, turn off the power, change the position of the rotary switch, and turn on the power again.

- (1) Rotary switch position in normal operation: 0
  1. The CNC and display unit wait for communication to be established.
  2. The system waits for the battery to be charged completely (only when the battery unit is enabled).
  3. The system monitors a communication error and CNC system alarm.

- (2) Rotary switch position during startup of NCBOOT32 (during maintenance): F
1. The CNC and display unit wait for communication to be established.
  2. The system displays the BOOT screen.
  3. The system displays the IPL screen.
  4. The system displays the CNC power-on screen.
  5. The system monitors a communication error and CNC system alarm.

### 3. Descriptions of the BOOT and IPL screens

The operating procedure for the BOOT and IPL screens on the display unit for automobile manufacturers is the same as for the personal computer function with Windows<sup>®</sup> CE.  
See Appendix F.3 for the descriptions of the operating procedure.

## 2.5.3 Display Unit for Stand-Alone Type Control Unit (with Personal Computer Function with Windows<sup>®</sup> CE)

### - Display control board specification

	Name	Specification	Remark
Display control board (for 10.4"LCD)	For A13B-0201-B001,-B003,-B004, and -B006	A20B-8200-0740	
Display control board (for 12.1"LCD)	For A13B-0201-B011,-B013,-B014, and -B016	A20B-8200-0743	
Display control board (for 15"LCD)	For A13B-0201-B021,-B023,-B024, and -B026	A20B-8200-0741	

- Connector mounting location

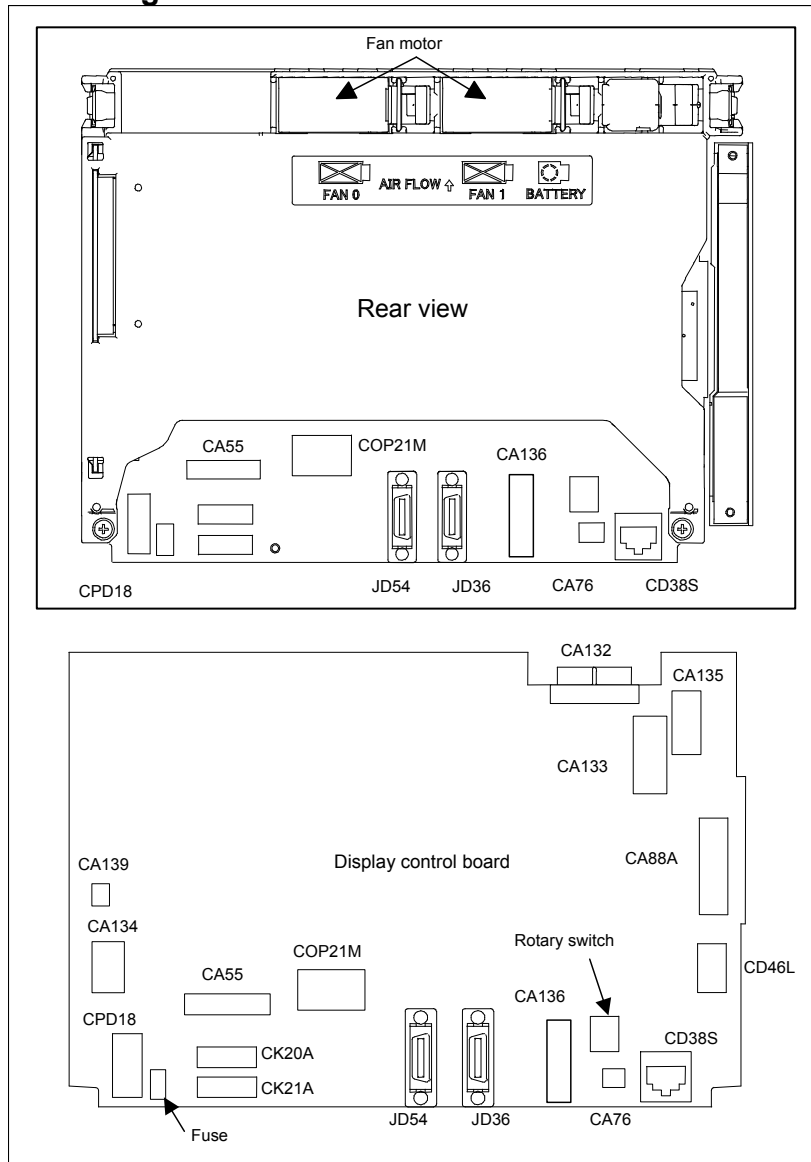

Connector number	Application
CA55	For MDI
JD36	For I/O device interface (RS-232C)
JD54	For I/O device interface (RS-232C) or USB device
CPD18	For power supply
CA133	For video signal interface (for 10.4"/12.1" display unit)
CA135	For video signal interface (for 15" display unit)
CA88A	For memory card interface
CD46L	For USB port
CK20A	For horizontal soft key
CK21A	For vertical soft key
CA132	For inverter board (for 10.4" display unit) For fan adapter board (for 12.1"/15" display unit)
COP21M	For HSSB interface
CD38S	For Ethernet (Windows CE control)
CA139	For touch panel interface
CA134	For inverter board (for 12.1"/15" display unit)
CA76	For buzzer interface

Connector number	Application
CA136	For backup unit

- Mounting positions of the GUI card, power supply unit, and compact flash card

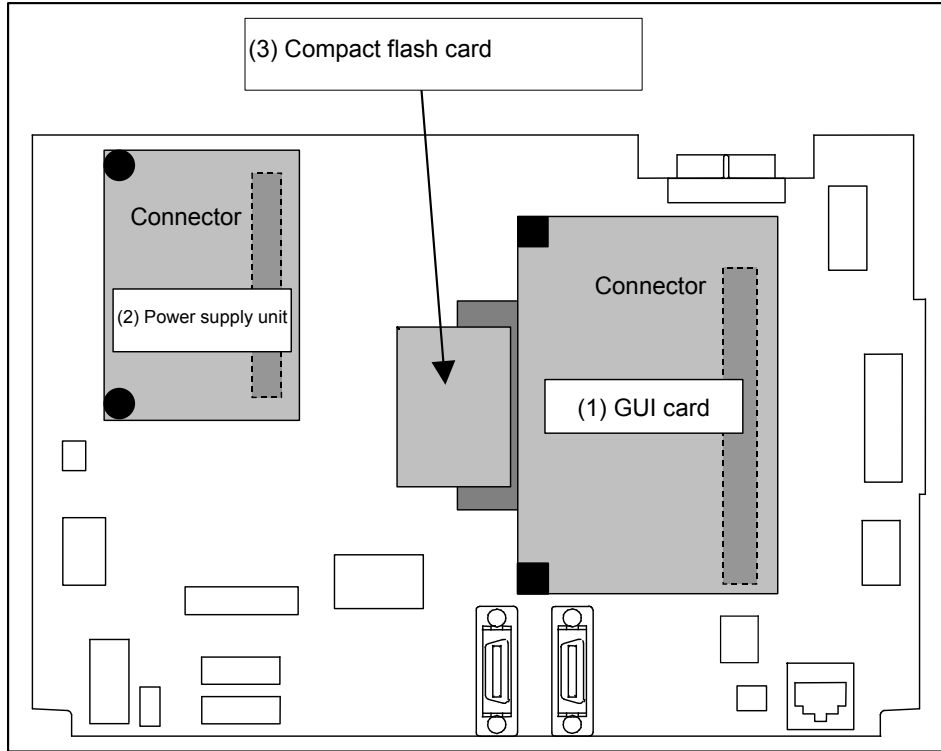

No.	Name	Specification	Remark
(1)	GUI card	A20B-3300-0670	
		A20B-3300-0671	
(2)	Power supply unit	A20B-8101-0011	
(3)	Compact flash card	A87L-0001-0173#128MBD	Total capacity: 128MB
		A87L-0001-0173#256MBD	Total capacity: 256MB
		A87L-0001-0173#512MBD	Total capacity: 512MB
		A87L-0001-0173#001GBD	Total capacity: 1GB
		A87L-0001-0173#002GBD	Total capacity: 2GB

- **Block diagram**

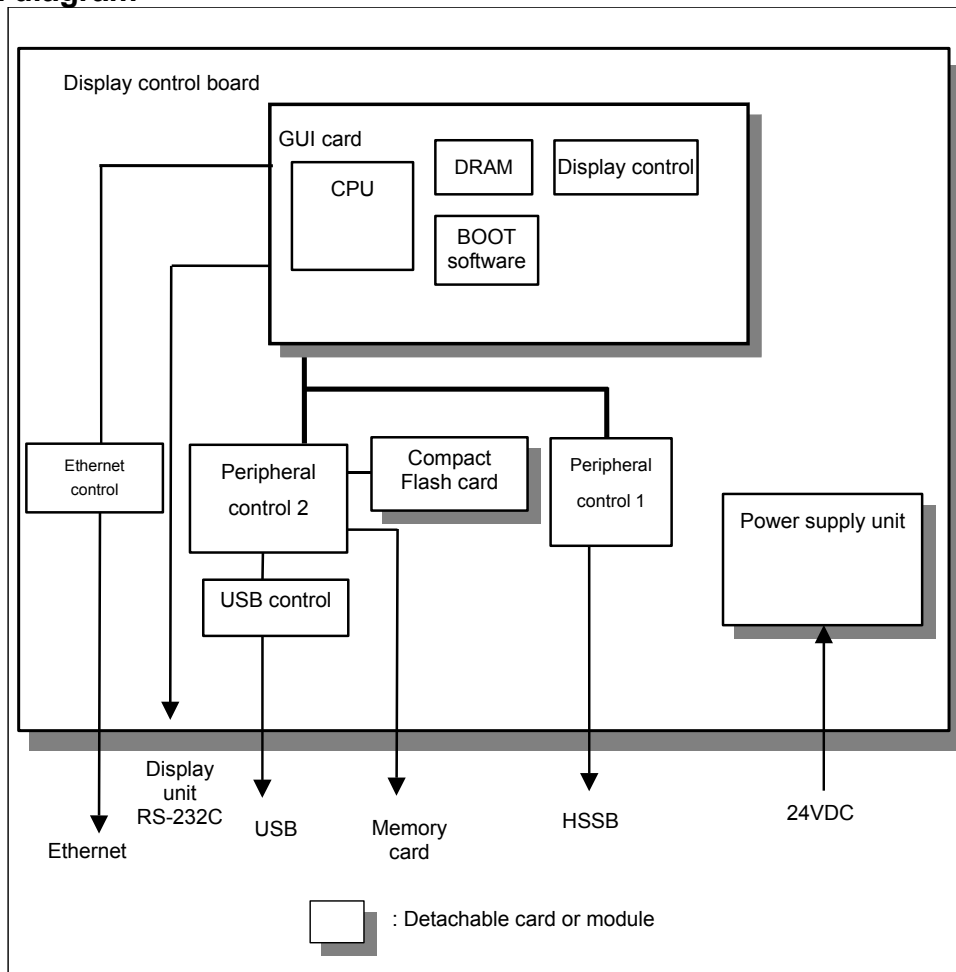



- LED display

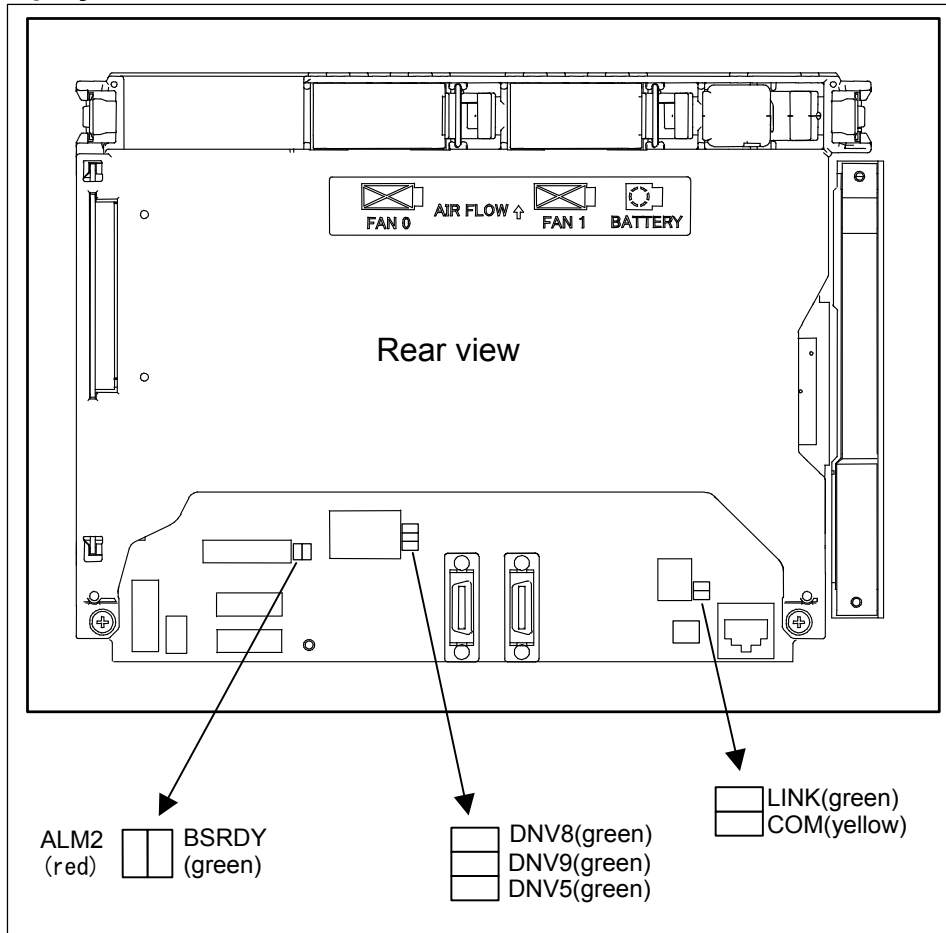

(1) HSSB status

LED	Meaning
BSRDY (green)	Lights when this board is normally connected to the control unit and communication is enabled.
ALM2 (RAME · red)	Indicates a common RAM error. It is likely that the display control board may be defective.

(2) Ethernet status

Name	Meaning
LINK (green)	Turned on when a connection is made with the hub correctly.
COM (yellow)	Turned on when data is transferred.

(3) Others (green LED)

Name	Meaning
DNV5 (LEDP)	Turned on when power is supplied to the GUI card.
DNV8 (LED2)	Indicates the operation status of the personal computer function.
DNV9 (LED1)	Indicates the operation status of the personal computer function.

**- Specifications of Inverter board and fan adapter board**

Name	Specification	Remark
Inverter board	For 10.4" LCD (working also as fan adapter board)	A20B-8200-0662
	For 12.1" LCD	A14L-0143-0003
	For 15" LCD	A14L-0168-0001
Fan adapter board	For 10.4" LCD (working also as fan adapter board)	Works also as the inverter board mentioned above.
	For 12.1" LCD	A20B-8200-0669
	For 15" LCD	
Connection cable between the display control board and the inverter board	For 12.1" LCD	A660-4042-T075#L90R00
	For 15" LCD	A660-4042-T076#L75R00

**- Details of the inverter board**

(1) For display unit with 10.4" LCD

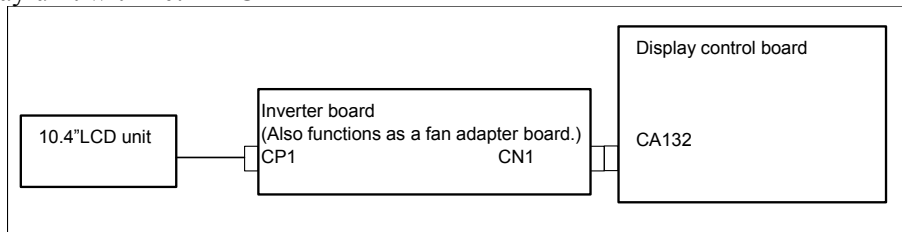

(2) For display unit with 12.1" LCD

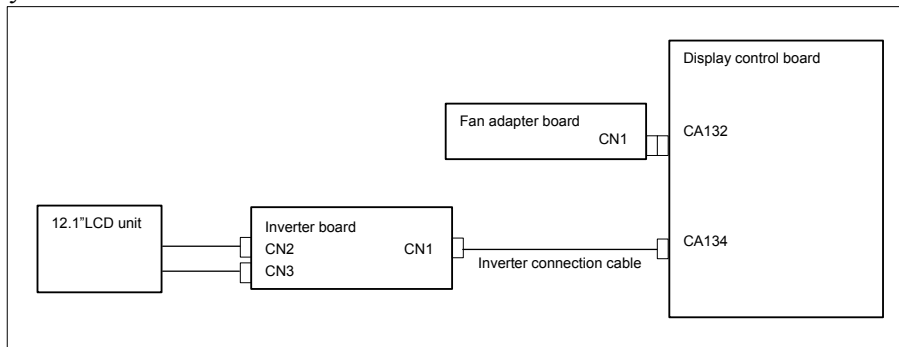

(3) For display unit with 15" LCD

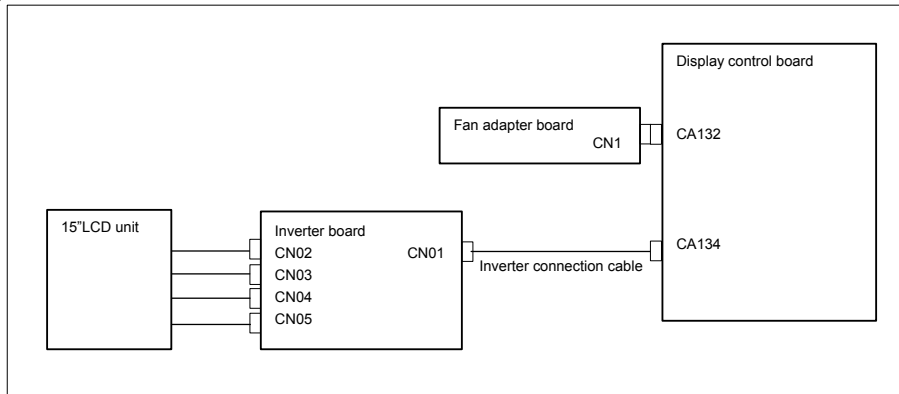

- **Locations of the inverter board and fan adapter board**

(1) For display unit with 10.4" LCD

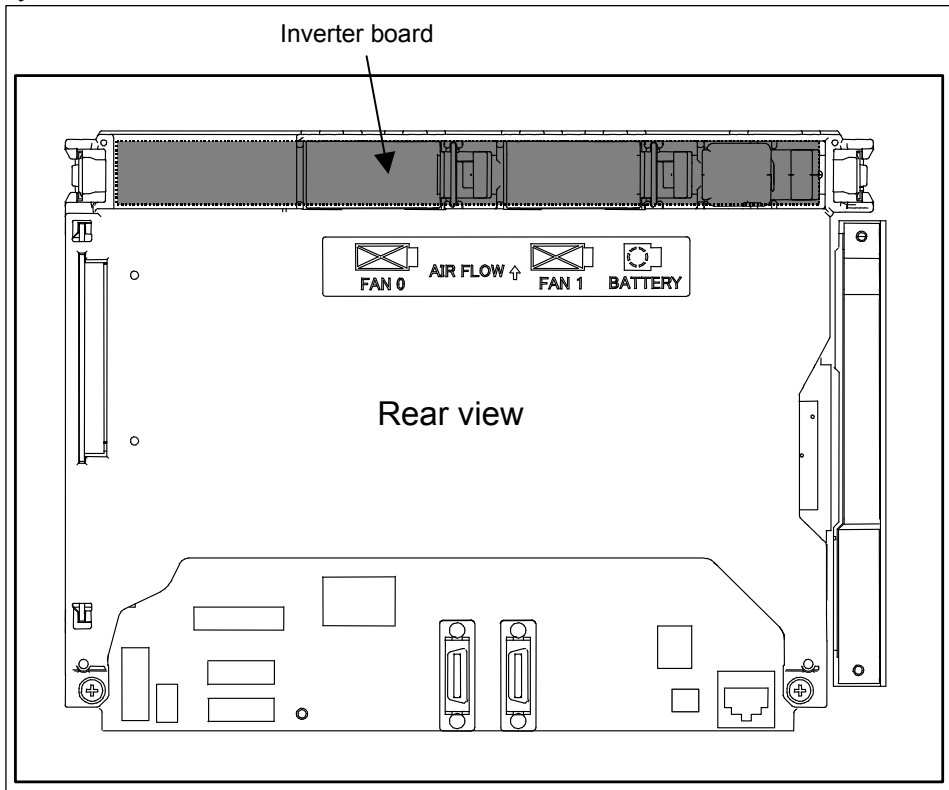

(2) For display unit with 12.1" LCD

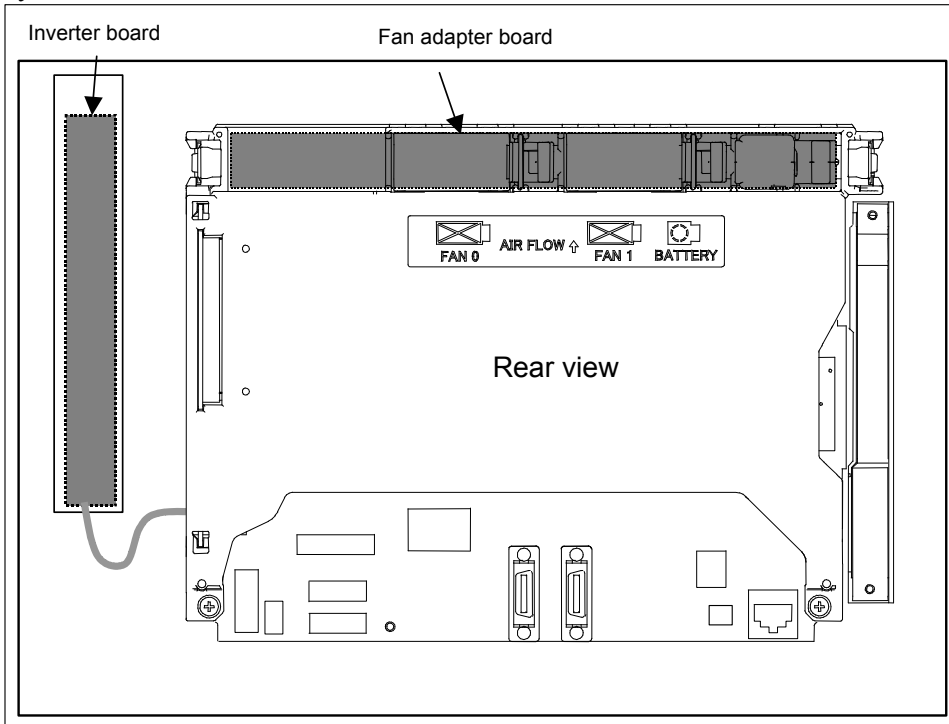

(3) For display unit with 15" LCD

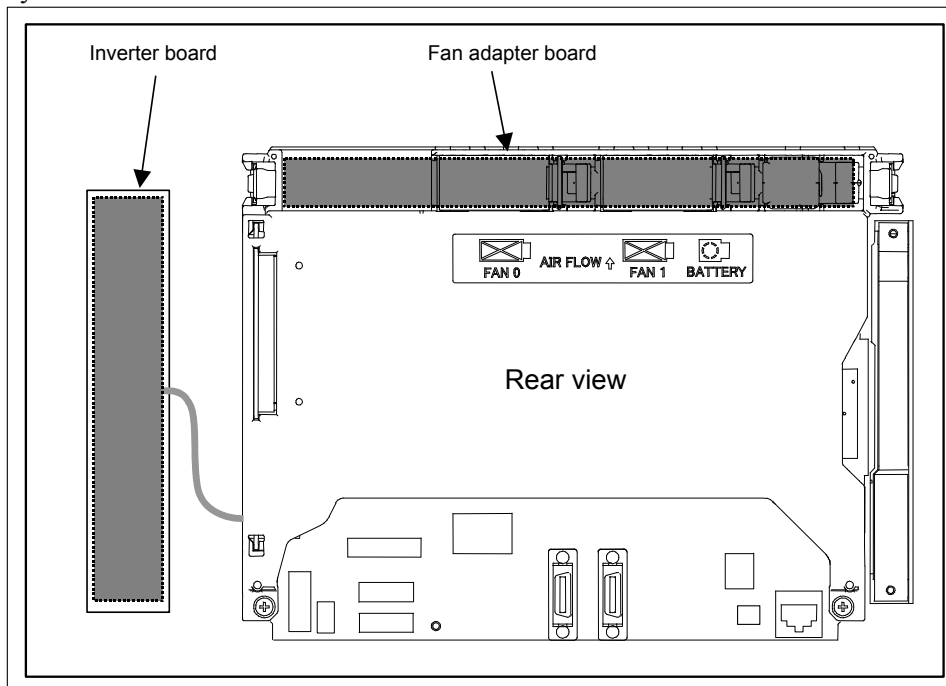

**- Connecting the display unit to the control unit**

For the display unit, place the rotary switch to 0 (initial setting).

Connection mode	Rotary switch setting
Default	0
Reserve	1 to F

**NOTE**

Do not set the rotary switch to the Reserve position.

**- Backup unit specification**

Name	Specification	Remark
Backup board	A20B-2100-0820	

See Subsection 2.4.3, “Bacup Unit”.

## 2.6 HARDWARE OF OPTIONAL BOARDS

### 2.6.1 Fast Ethernet Board

**- Specification**

Name	Specification	Remark
Fast Ethernet board	A20B-8101-0770	

**NOTE**

The Ethernet board may be used for the data server and FL-net functions as well as the Ethernet functions depending on parameter setting.

- Connector mounting location

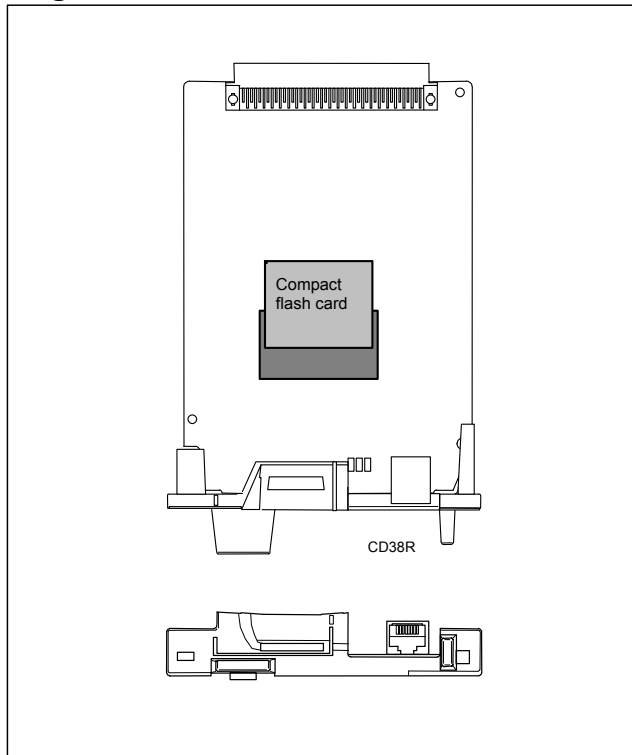

Connector number	Application
CD38R	For Ethernet

- LED display

The board incorporates four LEDs.  
The locations and meanings of the LEDs are indicated below.

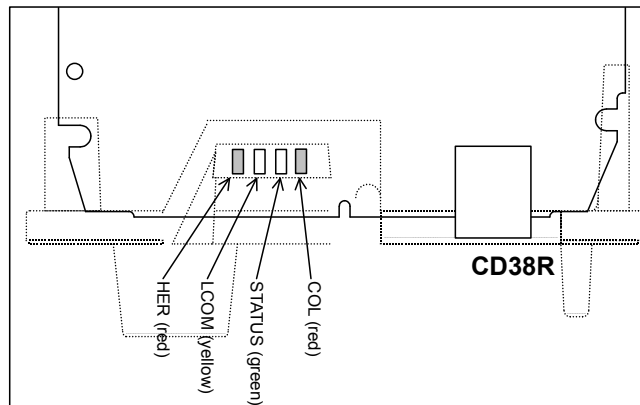

**NOTE**  
The face plate is indicated with dotted line.

In the following explanations, the LED lighting states are expressed as follows:

□: Off    ■: On    ☆: Blinking

LED display transition for STATUS (power on state)

LED display	Status	Meaning
□	Power-off	
■	Immediately after power-on	Initial state entered immediately after power-on. If the board is stopped in this condition, the cause is one of the following: → The CNC communication software may not be running normally. Check whether the communication software is installed properly. → The hardware may be faulty. Replace this board.
☆	Start completion	The board has started normally.

LED display transition for STATUS (during normal operation)

LED display	Status	Meaning
☆	Normal status	The board is operating normally.

LED display for LCOM

LED display	Status	Meaning
□	Not connected to hub	The board is not connected to the hub properly. The LED stays off also when the power to the hub is off. Check whether the board is connected to the hub properly.
■	Connected to hub	The board is connected to the hub.
☆	Transmission/reception in progress	Data is being transmitted or received.

LED display for COL

LED display	Status	Meaning
□	Normal status	The board is operating normally.
■	Collision occurs.	The LED is on or blinks at short intervals when the Ethernet communication traffic (communication amount) is high or ambient noise is high.
☆	(Data collision occurs.)	

LED display for HER

LED display	Status	Meaning
□	Normal status	The board is operating normally.
■	Error detected in the hardware	The cause may be a failure in this board or a malfunction due to noise.
☆	Error detected in the software	

## 2.6.2 Additional axis board

### - Specification

Name	Specification	Remark
Additional axis board	A20B-8101-0740	

**Connector and LED mounting location and LED display**

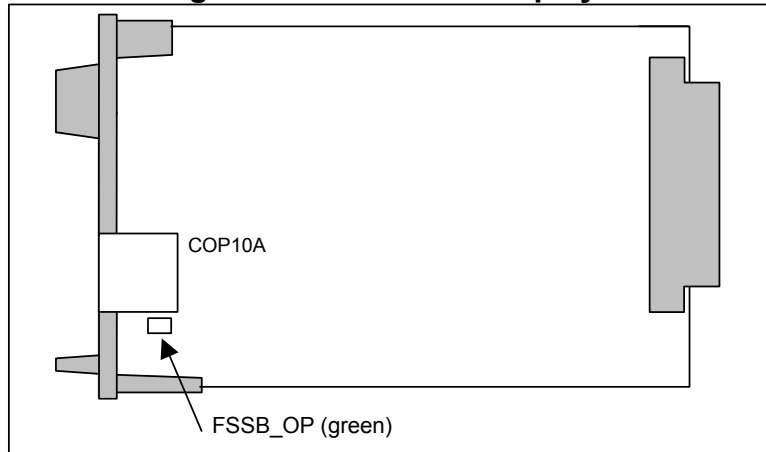

Connector number	Application
COP10A	For FSSB interface

**- LED display**

LED	Meaning
FBBS_OP (green)	ON: FSSB connected

**2.6.3 HSSB interface board**

**- Specification**

Name	Specification	Remark
HSSB interface board	A20B-8101-0111	

**- Connector and LED mounting location and LED display**

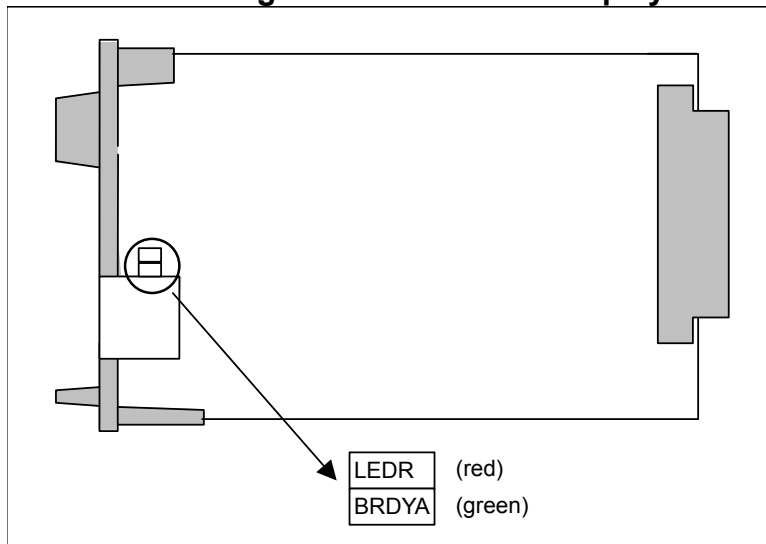

Connector number	Application
COP21N	For HSSB interface

**- LED display**

LED	Meaning
LEDR	Turned on when a common RAM parity error occurs in this board.

LED	Meaning
BRDYA	Lights to indicate that a link has been established.

## 2.6.4 PROFIBUS-DP Board

- Specification

Name	Specification	Remark
PROFIBUS-DP master board	A20B-8101-0050	
PROFIBUS-DP slave board	A20B-8101-0100	

Connector mounting location

- PROFIBUS-DP master board

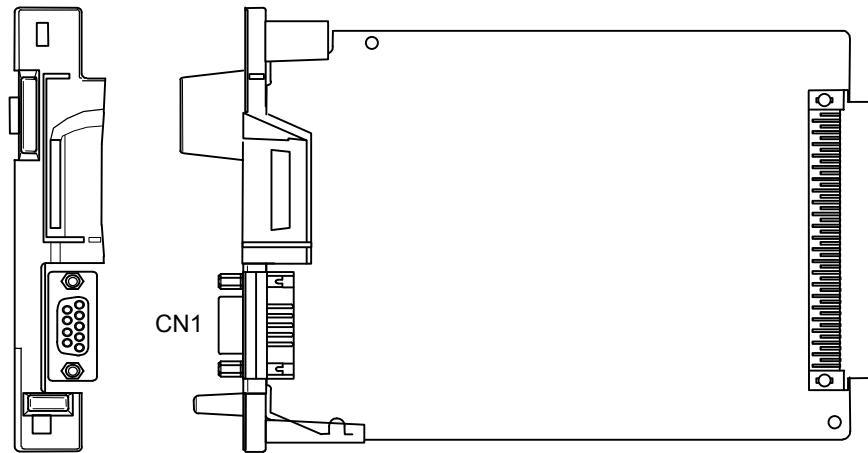

Connector number	Application
CN1	For PROFIBUS-DP master interface

- PROFIBUS-DP slave board

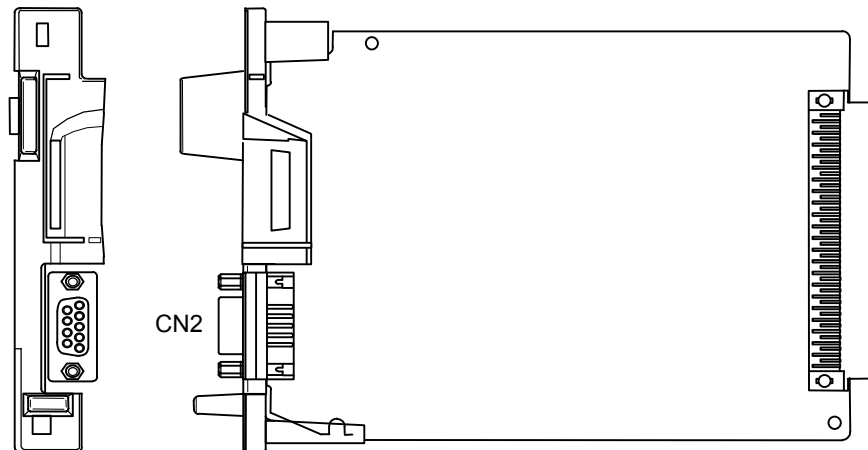

Connector number	Application
CN2	For PROFIBUS-DP slave interface



- LED display and their meanings
- PROFIBUS-DP master interface

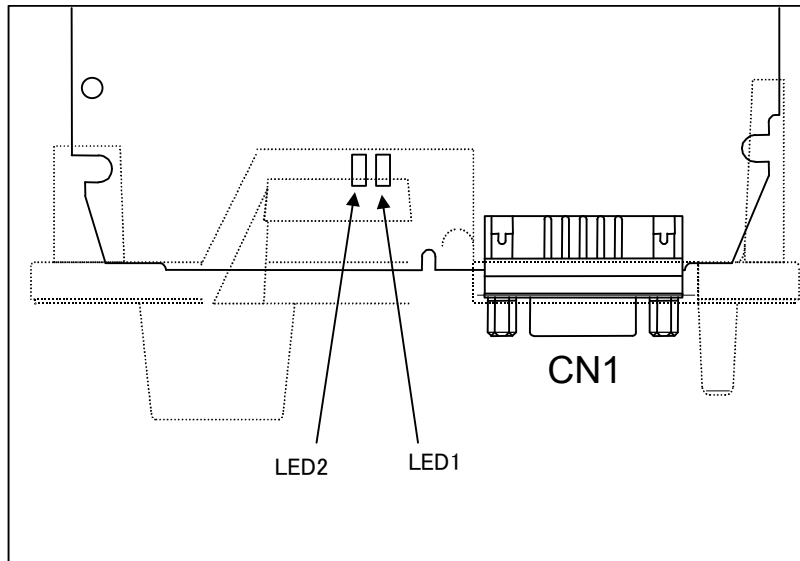

**NOTE**  
The face plate is indicated with dotted line.

- LED display

Name	Color	Description
LED1	Green	Indicates that the CPU on this board has started running. On: RESET has been released, allowing the CPU to start running. The LED is turned off when the power is turned on.
LED2	Green	Indicates whether communication is being normally carried out. On: Communication is being normally carried out. Off: Communication is not being carried out. The LED is turned off when the power is turned on.

- PROFIBUS-DP slave board

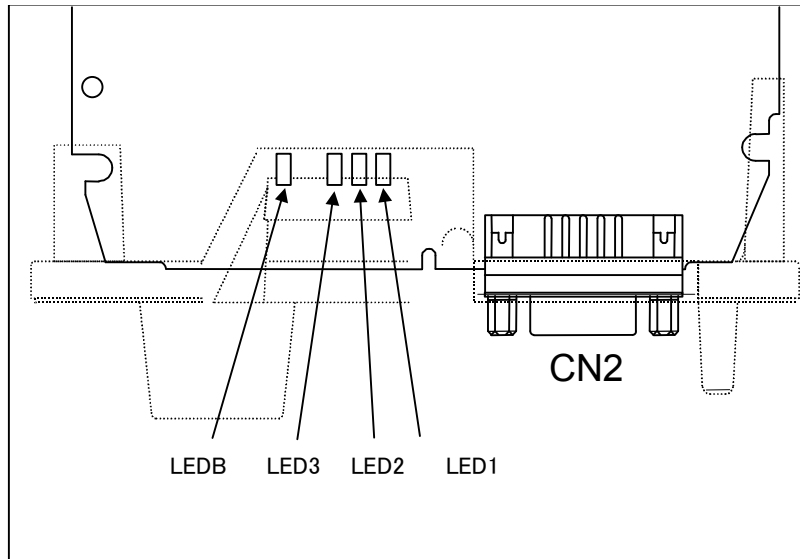

**NOTE**  
The face plate is indicated with dotted line.

- LED display

Name	Color	Description
LED1	Green	Indicates that the CPU on this board has started running. On: RESET has been released, allowing the CPU to start running. The LED is turned off when the power is turned on.
LED2	Green	Indicates that communication has started. On: Communication has started. The LED is turned off when the power is turned on or if: - No parameter data and configuration data have been received. - Invalid parameter data and configuration data have been received.
LED3	Green	Indicates whether communication is being normally carried out. On: Communication is being normally carried out. Off: Communication is not being carried out. The LED is turned off when the power is turned on.
LEDB	Red	Indicates that a RAM parity alarm condition has occurred on this board. On: A RAM parity alarm condition has occurred. The LED is turned off when the power is turned on. Once it has been turned on, it stays on until the power is turned off.

## 2.6.5 DeviceNet Board

### Specification

Name	Specification	Remark
DeviceNet master board	A20B-8101-0220	
DeviceNet slave board	A20B-8101-0330	

### Connector and LED mounting location

#### - DeviceNet master board

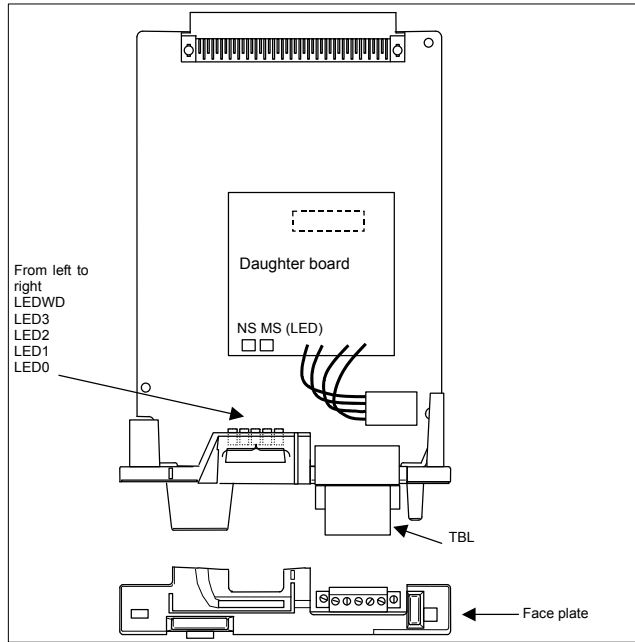

Connector number	Application
TBL	For DeviceNet interface

#### - DeviceNet slave board

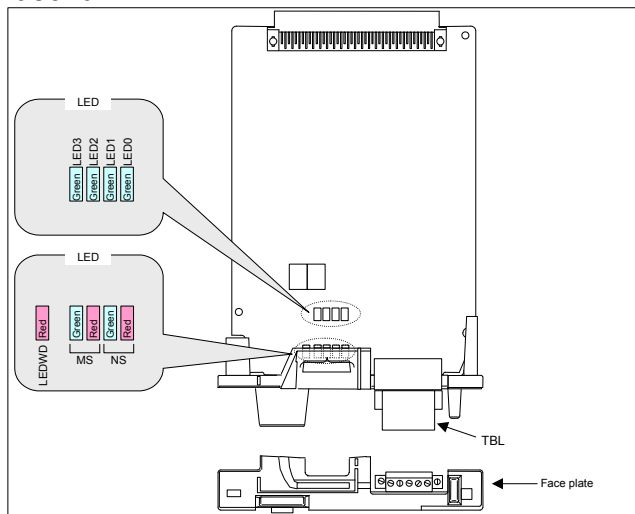

Connector number	Application
TBL	For DeviceNet interface

## LED display and their meanings

### - DeviceNet master board

This board provides four green LEDs and one red LED for status indication. In addition, the internal daughter board has two LEDs that emit red and green light.

Name	Color	Meaning
LED0 to 3	Green	Indicates the activation state of the DeviceNet application software.
LEDWD	Red	Indicates an error on the daughter board.
MS	Red / green	Indicates the module status, which is the status of the local node.
NS	Red / green	Indicates the network status, which is the status of the entire network including the local node.

In the following explanations, the LED lighting states are expressed as follows:

□: Off    ■: On    ☆: Blinking    ◇: Don't care

### LED display transition for LED0, LED1, LED2, and LED3 (during power-on)

LED 3 2 1 0	Status after power-on	Action when stopped after power-on
□□□□	Power-off	
■ ■ ■ ■	After power-on, the DeviceNet application software does not start.	The DeviceNet application software is not running normally. Check whether the software is installed properly.
□□□□	Initializing the firmware on the daughter board.	Replace the DeviceNet master board.
□□□■	Checking memory on the daughter board.	
□□■□	Recognizing the firmware on the daughter board.	
□□■ ■	Reading DeviceNet parameters.	Confirm that DeviceNet master function (software option) has been purchased.
□ ■ □ □	Verifying that DeviceNet parameter "NETWORK" is set to "ONLINE."	Set DeviceNet parameter "NETWORK" to "ONLINE."
□ ■ □ ■	Setting the bus parameter in DeviceNet parameters.	Replace the DeviceNet master board.
□ ■ ■ □	Setting the slave parameter in DeviceNet parameters.	Set the slave parameter in DeviceNet parameters correctly. If there is no problem with the setting, replace the DeviceNet master board.
□ ■ ■ ■	Checking duplicate MAC IDs.	Check duplication with the MAC ID of a slave device. Check if cables are connected correctly. Check if power for communication is correctly supplied. Check if slave devices are turned on.
■ □ □ □	The DeviceNet application software has been initialized and I/O communication starts.	

**LED display for LED1, LED2, LED3, and LED4 (when abnormality occurs)**

LED 3 2 1 0	Status	Meaning
□□□□ ↑ ↓ ■■■■ (Repetition)	Daughter board failure	The daughter board failed. Replace the DeviceNet master board.

**LED display for LEDWD**

LED display	Status	Meaning
■	Daughter board failure	The daughter board failed. Replace the DeviceNet master board.

**LED display of MS and NS (during normal operation)**

LED display	Status	Meaning
MS □ NS □	Immediately after power-on	The MPU on the daughter board is being reset.
MS ☆ green NS □	Initializing	The firmware on the daughter board is making a initialization.
MS ■ green NS □	Checking duplication of MAC IDs	The firmware on the daughter board is checking duplicated MAC IDs.
MS ■ green NS ☆ green	I/O communication stopped	The firmware on the daughter board is stopping I/O communication.
MS ■ green NS ■ green	I/O communication in advance	The firmware on the daughter board is successfully performing I/O communication.

**LED display of MS and NS (during occurrence of an error)**

LED display	Status	Error and action
MS ☆ red NS ◇	Daughter board failure	A MAC ID or communication rate setting error occurred or the daughter board failed. When the setting is correct, replace the DeviceNet master board.
MS ■ red NS □	Daughter board failure	The daughter board failed. Replace the DeviceNet master board.
MS ◇ NS ■ red	Duplicate MAC IDs	MAC IDs are duplicate. Verify the following: → MAC IDs are not duplicate by check the MAC IDs of all nodes.
	Busoff detection	Communication stopped because a communication error occurred frequently. Verify the following: → The communication rates of all nodes are set to the same value. → The cable length is appropriate. → The cable is not loose or broken. → A terminal is placed on only both ends of the main line. → There is not much noise.
MS ◇ NS □	Network power failure	Power for communication is not supplied. Verify the following: → Power for communication is properly supplied.
	Transmission error	Transmission is not completed successfully. Verify the following: → All slaves are turned on. → There is no other master on the network. → The communication rates of all nodes are set to the same value. → The cable length is appropriate. → The cable is not loose or broken. → A terminal is placed on only both ends of the main line. → There is not much noise.
MS ◇ NS ☆ red	Slave not present	No slaves are present. Verify the following: → The slave is turned on. → The communication rates of all nodes are set to the same value. → The cable length is appropriate. → The cable is not loose or broken. → A terminal is placed on only both ends of the main line. → There is not much noise.
	Slave I/O size mismatch	The slave I/O size setting does not match the setting of the actual slave. Verify the following: → The slave I/O size setting matches the setting of the actual slave.
	I/O communication error	I/O communication timed out. Verify the following: → The communication rates of all nodes are set to the same value. → The cable length is appropriate. → The cable is not loose or broken. → A terminal is placed on only both ends of the main line. → There is not much noise.

### DeviceNet slave board

This board provides four green LEDs (LED0 to LED3) and one red LED (LEDWD) for status indication. In addition, there are two LED sets (MS and NS) that consist of one red LED and one green LED.

Name	Color	Meaning
LED0 to 3	Green	Indicates the activation state of the DeviceNet application software.
LEDWD	Red	Indicates an error on the DeviceNet slave board.
MS	Green	Indicates the module status, which is the status of the local node.
	Red	
NS	Green	Indicates the network status, which is the status of the entire network including the local node.
	Red	

In the following explanations, the LED lighting states are expressed as follows:

□: Off    ■: On    ☆: Blinking    ◇: Don't care    ? : Undefined

### LED display transition for LED0, LED1, LED2, and LED3

LED 3 2 1 0	Status and cause when stopped after power-on	Action when stopped after power-on
□□□□	Power-off	
■ ■ ■ ■	After power-on, the DeviceNet application software does not start. Or, the DeviceNet slave function (software option) is disabled.	The DeviceNet application software is not running normally. Check whether the software is installed properly. Or, confirm that the DeviceNet slave function (software option) has been purchased.
□□□□	Initializing the firmware.	Replace the DeviceNet slave board.
□□□■	Firmware has been initialized.	
□□■□	A line baud rate check is in progress.	Check the status of communication with the DeviceNet master.
□□■■	Checking duplication of MAC IDs	
□■□□	Waiting for I/O communication to be established.	A network power failure may also occur. Check whether the power for communication is supplied properly.
□■□■	I/O communication is normal.	
□■■□	I/O communication has timed out.	If the system does not recover from the error, replace the DeviceNet slave board.
□■■■	I/O communication is idle.	

### LED display for LEDWD

LED display	Status	Meaning
■	Board failure	The DeviceNet slave board failed. Replace the DeviceNet slave board.

**LED display of MS and NS (during normal operation)**

In the “during normal operation” status, when communication is normally established, a transition to the “I/O communication normal” status is made.

LED display	Status	Meaning
MS <input type="checkbox"/> green MS <input type="checkbox"/> red NS <input type="checkbox"/> green NS <input type="checkbox"/> red	Immediately after power-on	The onboard firmware is being initialized when the onboard MPU is in the reset status or reset release status.
MS <input checked="" type="checkbox"/> green MS <input type="checkbox"/> red NS <input type="checkbox"/> green NS <input type="checkbox"/> red	Communication under preparation	The onboard firmware performs processing in the order below. (1) Waits for the DeviceNet application software to be initialized. (2) Checks the baud rate. (3) Checks MAC ID duplication.
MS <input checked="" type="checkbox"/> green MS <input type="checkbox"/> red NS ☆ green NS <input type="checkbox"/> red	Waiting for I/O communication to be established.	Each status corresponds to DeviceNet MPU status transition.
MS <input checked="" type="checkbox"/> green MS <input type="checkbox"/> red NS <input checked="" type="checkbox"/> green NS <input type="checkbox"/> red	I/O communication is normal.	
MS ◇ green MS ◇ red NS <input checked="" type="checkbox"/> green NS ☆ red	I/O communication has timed out.	

**NOTE**

When a transition to the "I/O communication normal" status is not made, confirm that the power for communication is correctly supplied because a network power failure may have occurred.



**LED display of MS and NS (during occurrence of an unrecoverable failure)**

In the "during occurrence of an unrecoverable failure" status, once an error occurred, recovery is not performed unless this slave station is powered off and back on again.

LED display	LED 3 2 1 0	Status	Error and action
MS ◇ green MS ◇ red NS □ green NS ■ red	■ □ □ □ ↑ ↓ □ □ ■ □ (Repetition)	Duplicate MAC IDs	Check the following and then turn the slave power off and back on again. → MAC IDs are not duplicate by check the MAC IDs of all nodes.
	■ □ □ □ ↑ ↓ □ □ ■ ■ (Repetition)	Busoff detection	Check the following and then turn the slave power off and back on again. → The communication rates of all nodes are set to the same value. → The cable length is appropriate. → The cable is not loose or broken. → A terminal is placed on only both ends of the main line. → There is not much noise.
MS □ green MS ■ red NS ◇ green NS ◇ red	■ □ □ □ ↑ ↓ □ ? ? ? (Repetition)	Board failure	The DeviceNet slave board failed. Replace the DeviceNet slave board.
MS ◇ green MS ◇ red NS ◇ green NS ◇ red	□ □ □ □ ↑ ↓ ■ ■ ■ ■ (Repetition)	An unrecoverable failure occurred on the CNC side.	Contact FANUC.

**2.6.6 CC-Link Board**

**Specification**

Name	Specification	Remark
CC-Link remote device station board	A20B-8101-0551	

**Connector and LED mounting location  
CC-Link remote device station board**

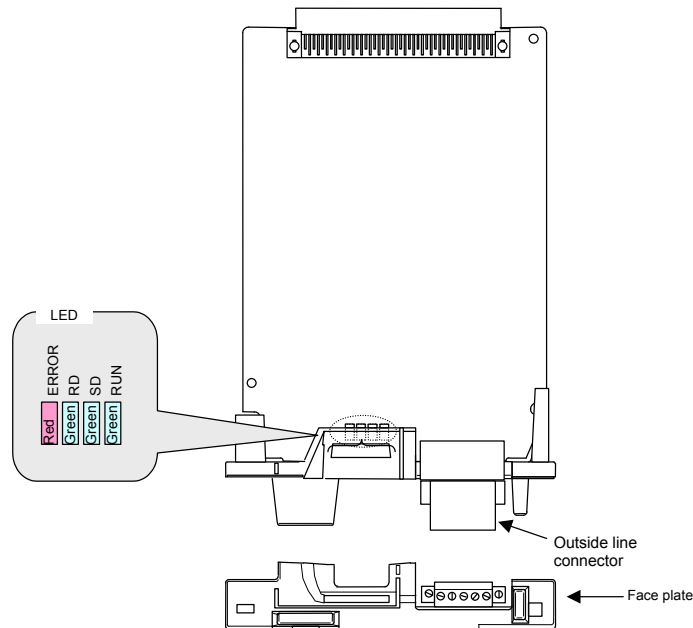

## LED display and their meanings

### - CCC-Link remote device station board

This board provides three green LEDs and one red LED for status indication.

Name	Color	On	Off
RUN	Green	Online	Offline
SD	Green	Sending data.	Not sending data.
RD	Green	Channel carrier detected.	Channel carrier error.
ERROR	Red	CRC error detected.	Communicating normally.

In the usual, normal communication state, the on/off states of the LEDs are as follows:

Name	On/off state
RUN	On
SD	Blinking
RD	On
ERROR	Off

#### NOTE

If the number of units on the network is small, SD blinks at high speed, and it may appear on not instead of blinking to the human eye.

## LED indicators in the event of an error

In any of the following LED states, check the settings as listed in the table below.

□: Off    ■: On    ☆: Blinking    ◇: Don't care

LED				Meaning of the state	Check item
RUN	SD	RD	ERR		
◇	◇	◇	☆	<ul style="list-style-type: none"> <li>A CRC error occurred.</li> </ul>	Cable connection Terminating resistors Measures against noise Baud rate
■	□	■	□	<ul style="list-style-type: none"> <li>Data destined to the local station cannot be received from the master station.</li> </ul>	Settings of the master station
□	☆	■	□	<ul style="list-style-type: none"> <li>The master station is not link-started.</li> </ul>	Settings of the master station
□	□	■	□	<ul style="list-style-type: none"> <li>Data cannot be received.</li> </ul>	Cable connection Measures against noise Settings of the master station
□	□	□	□	<ul style="list-style-type: none"> <li>The cable is disconnected.</li> <li>The master station is not turned on.</li> </ul>	Cable connection Settings of the master station

Check item	What to check
Cable connection	<ul style="list-style-type: none"> <li>The cable is not connected.</li> <li>The cable and the connector are connected together correctly.</li> <li>The cable is not bend forcibly.</li> <li>The inter-slave station distance is correct.</li> </ul>
Terminating resistors	<ul style="list-style-type: none"> <li>Terminating resistors are connected to both ends of the cable.</li> <li>The terminating resistors match the cable type.</li> </ul>
Measures against noise	<ul style="list-style-type: none"> <li>Each unit is grounded.</li> </ul>
Baud rate	<ul style="list-style-type: none"> <li>The same baud rate is set for the master and slave stations.</li> </ul>
Settings of the master station	<ul style="list-style-type: none"> <li>The master station is turned on.</li> <li>The master station is operating normally.</li> <li>The settings of the master station are made correctly.</li> </ul>

## 2.7 ENVIRONMENTAL REQUIREMENTS OUTSIDE THE CABINET

### 2.7.1 Environmental Conditions outside the Cabinet

The control unit and the peripheral units have been designed on the assumption that they are housed in closed cabinets. In this manual "cabinet" refers to the following:

- Cabinet manufactured by the machine tool builder for housing the control unit or peripheral units;
- Operation pendant, manufactured by the machine tool builder, for housing the display unit, MDI unit, or operator's panel.
- Equivalent to the above.

The following table lists the environmental conditions required in installing these cabinets.

Ambient temperature of the cabinet	Operating	0°C to 45°C
	Nonoperating (including storage and transportation)	-20°C to 60°C
	Temperature change	0.3°C/minute or less
Humidity	Normal	75%RH or less, no condensation
	Short period (less than 1 month)	95%RH or less, no condensation
Vibration	Operating	0.5G or less
	Nonoperating (including storage and transportation)	1.0G or less
Meters above sea level	Operating	Up to 1000 m <small>(see Note 1 in the Subsec. 2.7.2.)</small>
	Nonoperating (including storage and transportation)	Up to 12000 m
Environment	Normal machine shop environment (The environment must be considered if the cabinets are in a location where the density of dust, coolant, organic solvent, and/or corrosive gas is relatively high.)	

### 2.7.2 Installation Conditions of the Control Unit

Condition		LCD-mounted type control unit and display unit	Stand-alone type control unit
Ambient temperature	Operating	0°C to 58°C	0°C to 55°C
	Nonoperating (including storage and transportation)	-20°C to 60°C	
	Temperature change	0.3°C/minute or less	
Humidity	Normal	75%RH or less, no condensation	
	Short period (less than 1 month)	95%RH or less, no condensation	
Vibration	Operating	0.5G or less FANUC's evaluation test was conducted under the following conditions complying with IEC 60068-2-6. 10 to 58Hz: 0.075mm (amplitude) 58 to 500Hz: 1G Direction of vibration: Each of the X, Y, and Z directions Number of sweep cycles: 10	
	Nonoperating (including storage and transportation)	1.0G or less	
Meters above sea level	Operating	Up to 1000m <small>(Note 1)</small>	
	Nonoperating (including storage and transportation)	Up to 12000m	

Condition	LCD-mounted type control unit and display unit	Stand-alone type control unit
Environment	Coolant, lubricant, or cutting chips shall not be sprinkled directly over the CNC or servo unit. No corrosive gas shall be allowed.	

**NOTE**

- 1 If the control unit is installed 1000 m or higher above sea level, the allowable upper ambient temperature of the control unit in the cabinet is changed as follows. Assume that the allowable upper ambient temperature of the control unit in the cabinet installed 1000 m or higher above sea level decreases by 1.0°C for every 100 m rise in altitude.

Example)

When a control unit whose required operating ambient temperature range is 0°C to 55°C is installed 1750 m above sea level:

$$55^{\circ}\text{C} - (1750\text{m} - 1000\text{m}) / 100\text{m} \times 1.0^{\circ}\text{C} = 47.5^{\circ}\text{C}$$

Therefore, the allowable ambient temperature range is from 0°C to 47.5°C.

- 2 When using a unit having additional installation conditions, be sure to meet also these conditions.

## 2.8 CAUTIONS RELATED TO GROUNDING AND NOISE

The cabinet and pendant box generally have measures against electrical shocks and noise, such as connecting grounding wires and separating cables on routing, in them. If you removed grounding wires from the cabinet or pendant box, for example, in replacing a control or peripheral unit in the cabinet or pendant box or if you temporarily changed the way other cables are laid or bound, basically restore their original state of connection after maintenance work. Otherwise, it is likely that an electrical shock or noise may result and the unit may malfunction.

This section describes the concept of cable separation, a noise suppresser as a measure against noise, cable clamping and shield processing, and a lightning surge absorber.

### 2.8.1 Separating Cables

The cables used for the CNC machine tool are classified as listed in the following table. The cables in each group must have been subjected to treatment stated in the Action column.

**Table 2.8.1 Cable grouping**

Group	Signal line	Action
A	Primary AC power line	Bind the cables in group A separately <sup>(Note 1)</sup> from groups B and C, or cover group A with an electromagnetic shield <sup>(Note 2)</sup> . See Subsection 2.8.2 and connect spark killers or diodes with the solenoid and relay.
	Secondary AC power line	
	AC/DC power lines (containing the power lines for the servo and spindle motors)	
	AC/DC solenoid	
	AC/DC relay	
B	DC solenoid (24 VDC)	Connect diodes with the DC solenoid and relay. Bind the cables in group B separately from group A, or cover group B with an electromagnetic shield. Separate group B as far from group C as possible. It is desirable to apply shield processing described in Subsection 2.8.3.
	DC relay (24 VDC)	
	DI/DO cable between the I/O unit and power magnetics cabinet	
	DI/DO cable between the I/O unit and machine	
	24 VDC input power cables connected to the control unit and its peripherals	

Group	Signal line	Action
C	I/O Link <i>i</i> or I/O Link cable	Bind the cables in group C separately from group A, or cover group C with an electromagnetic shield. Separate group C as far from group B as possible. Be sure to perform shield processing as described in Subsection 2.8.3.
	Cable for the position coder	
	Cable for the manual pulse generator	
	Cable for the MDI <sup>(NOTE 3)</sup>	
	RS-232C interface cable	
	Cable for the battery	
	Cable for the Ethernet	
	Other cables for which shield processing is specified	

**NOTE**

- 1 Binding the cables in one group separately from another means that the groups are placed 10 cm or more apart from one another.
- 2 Covering a group with an electromagnetic shield means that shielding is provided between groups with grounded steel plates.
- 3 The shield is not required when the cable for the MDI is no more than 50 cm in length.

**CAUTION**

Select a cable with a proper length. If the cable is too long, the noise immunity may be reduced or noise may be caused on other cables. In addition, when the excess length is coiled, the inductance is increased and a high voltage is induced during turning on or off of signals. This may cause a failure or a malfunction due to noise.

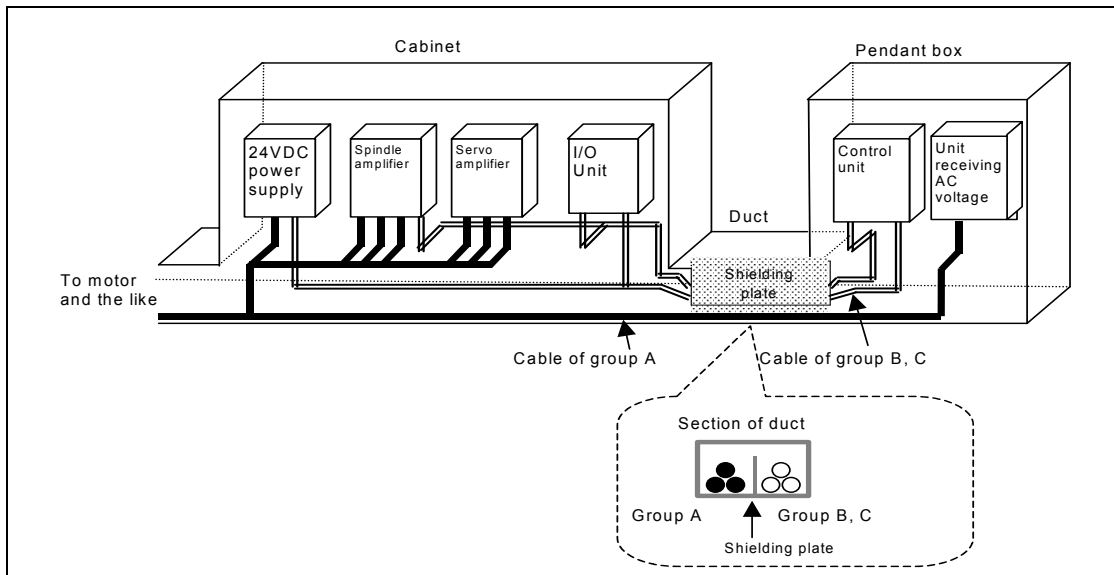

Fig. 2.8.1 Cable layout example

## 2.8.2 Noise Suppressor

A noise suppressor must be installed as a measure against noise that may occur in actuators such as solenoids and relays used in the power magnetics cabinet.

Because an actuator, which converts electrical energy to mechanical action, is an inductive load, it resonates with the parasitic capacitance in a circuit containing it, when it works on and off, thus generating intermittent arcs accompanied by abrupt voltage rises and falls at its contacts, hence electromagnetic waves interfering with electronics circuits. As a remediation measure, treat the inductive load as described below.

- 1) While referencing the processing for cable groups A and B described in Subsection 2.8.1, “Separating Signal Lines”, apply a CR snubber circuit and a diode, respectively, to an inductive load in an AC circuit and that in a DC circuit.
- 2) When selecting a CR snubber or diode, observe the following cautions.

### Cautions for selecting and using a CR snubber

- Use a CR snubber in an AC circuit.  
A varistor, voltage clamping element, can limit the peak of an oscillating voltage waveform but cannot relax an abrupt voltage transition. For this reason, we recommend using a CR snubber rather than the varistor.
- Determine the rating of the resistor and capacitor in the CR snubber according to the steady-state current  $I$  (A) and DC resistance  $R_L$  ( $\Omega$ ) of the inductive load as follows:
  - 1) CR snubber resistance:  $R \cong R_L(\Omega)$
  - 2) CR snubber capacitance:  $\frac{I^2}{10} \leq C \leq \frac{I^2}{20}$  ( $\mu\text{F}$ )
- Place the CR snubber close to the inductive load to minimize its wiring.

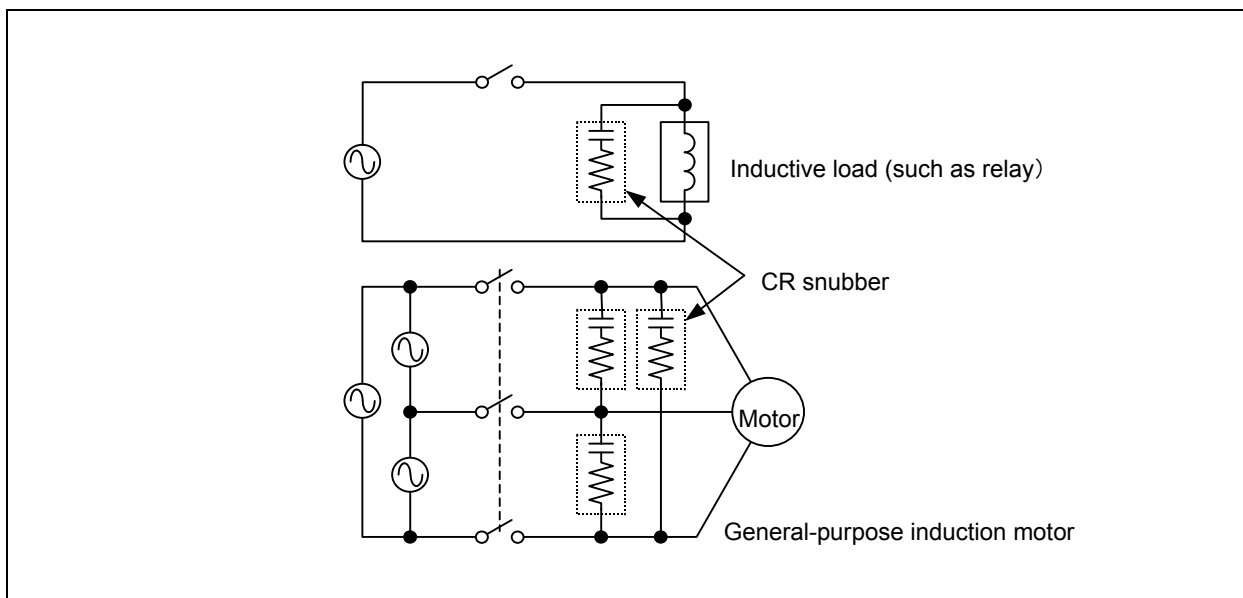

Fig. 2.8.2 (a) Example of applying a CR snubber

### Cautions for selecting and using a diode

- A diode (freewheeling diode) can be used as a noise suppressor for a DC driver circuit.
- Determine the ratings of the diode according to the drive voltage and current for the inductive load (such as a solenoid coil, relay, or motor) as follows:
  - 1) Voltage rating: Approximately twice the voltage applied to the inductive load
  - 2) Current rating: Approximately twice the steady-state current flowing through the inductive load

- Place the diode close to the inductive load in order to minimize its wiring.

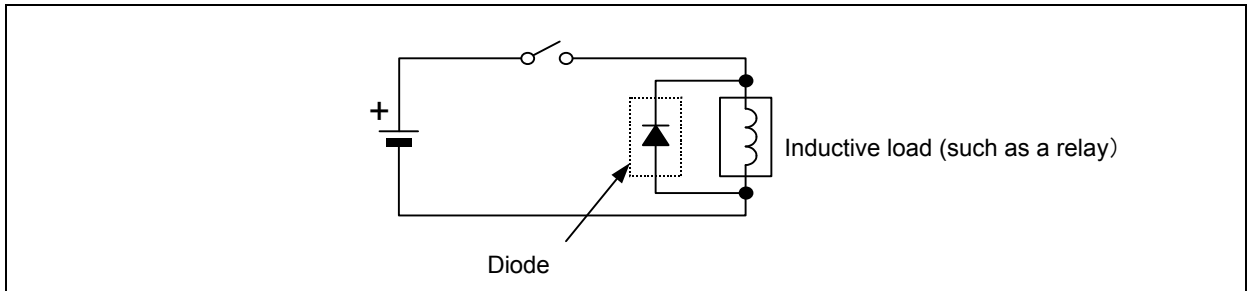

Fig. 2.8.2 (b) Example of applying a diode

### 2.8.3 Cable Clamp and Shield Processing

Each cable leading into this control unit, servo amplifiers, or spindle amplifiers that requires shielding so as to suppress external noise has been clamped (basically signal cables require shield clamps). So when the cable replaced by a new one, confirm that the shield processing complies with following requirements.

Partially peel the sheath off each of such cables and expose the shield, and press the exposed portion against a ground bar with a clamp. Care should be taken so that the ground bar and shield have a surface contact in a larger area.

The ground bar for the cable clamp must be installed as shown in Fig. 2.8.3 (a).

When the multipoint grounding scheme is used, care should be taken so that the ground bar for the shield clamp and cabinet are connected at low impedance by, for example, preventing the cabinet side contact surface from being coated.

When using an in-line connector or the like to split a cable, it is necessary to connect the shield of one portion of the cable and that of the other portion and to keep the total impedance of the two cable portions from becoming high. Even if the connector is placed at the inlet of the cabinet, it is also necessary to use the shield for the intra-cabinet portion of the cable all the way to the other end of the cable.

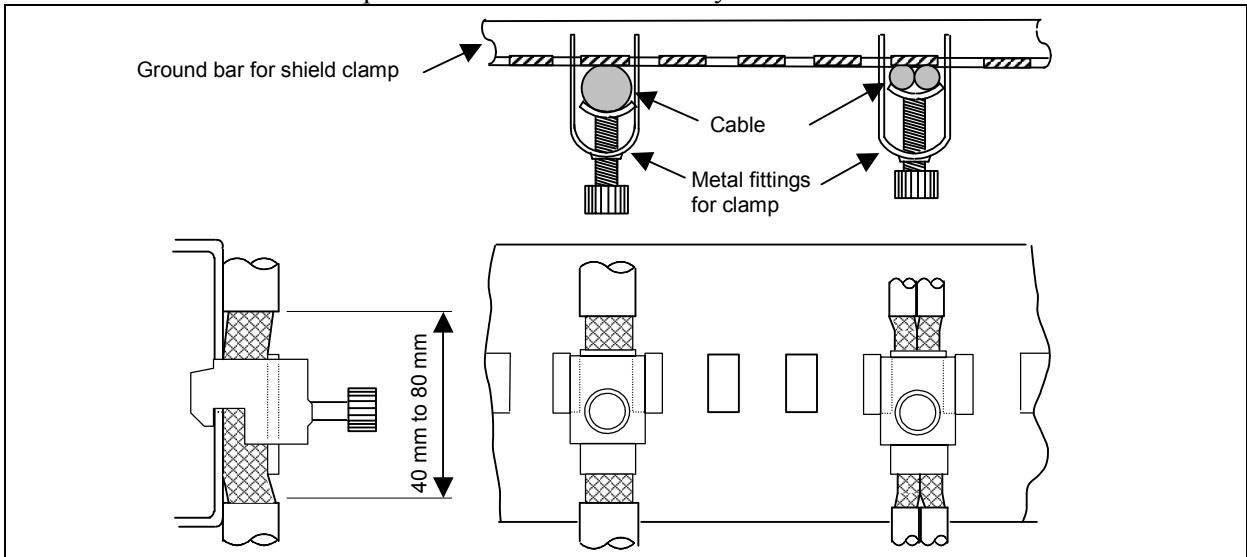

Fig. 2.8.3 (a) Cable clamp (1)

**NOTE**

Bundle and clamp the shields of cables that lead into the control unit or amplifier at a point, respectively, close to the unit or amplifier.

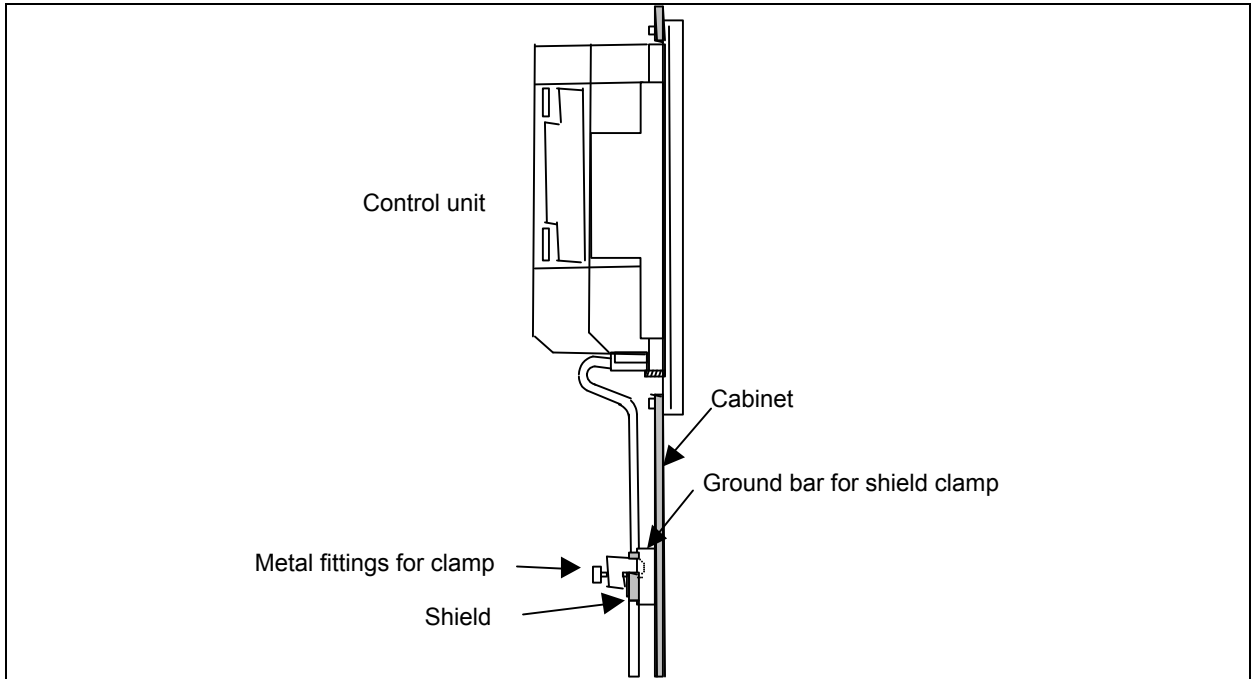

Fig. 2.8.3 (b) Cable clamp (2)

Prepare a ground bar for cable clamping shown below.

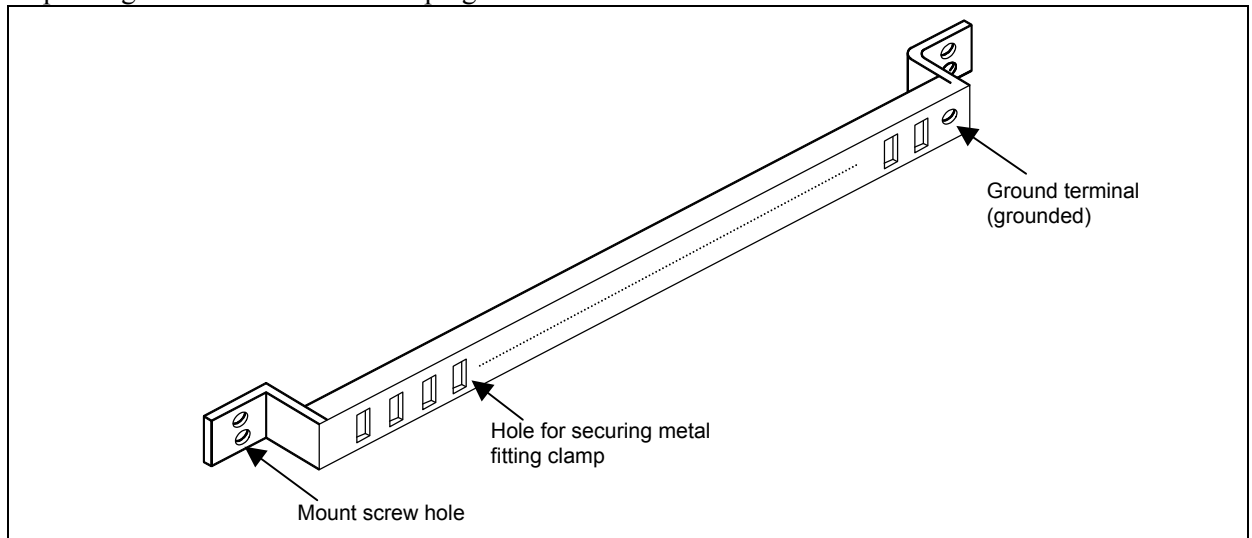

Fig. 2.8.3 (c) Ground bar for shield clamp (outline drawing)

The ground bar for cable clamping must be made of a steel plate at least 2 mm thick and plated with nickel.

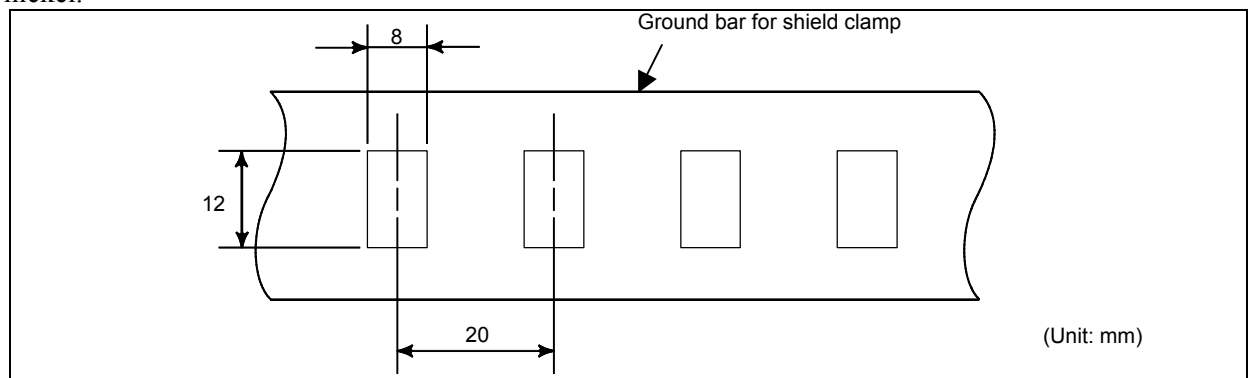
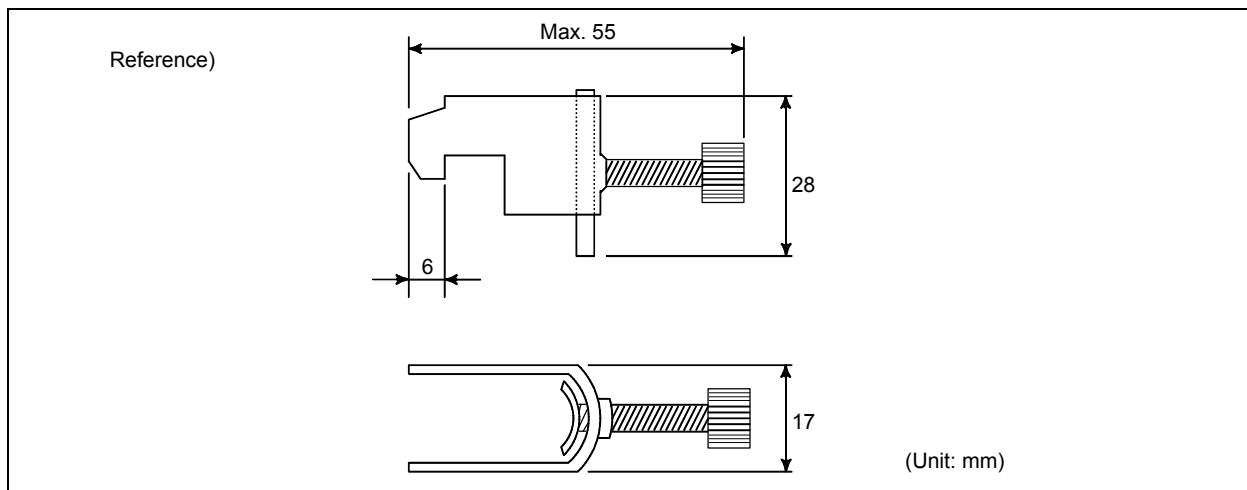

Fig. 2.8.3 (d) Ground bar for shield clamp (hole arrangement and dimension drawing)





**Fig. 2.8.3 (e) Clamping metal fixture (outline drawing)**

Ordering specification for metal fittings for clamp  
A02B-0303-K001 (8 pieces)

## 2.8.4 Lightning Surge Absorber

A lightning surge absorber installed between input power lines and between input power lines and the ground might be effective to protect units from lightning voltage surges. However, installing a surge absorber does not always ensure protection from lightning surges. How to install the lightning surge absorber is explained below.

### Installation procedure

The surge-absorbing elements used for measures against surges due to lightning must be installed in the input power unit as shown in the figure below. The figure below shows an example in which an insulating transformer, shown by dotted lines, is not installed. If an insulating transformer is installed, surge-absorbing element 2 (between line and ground) is not required.

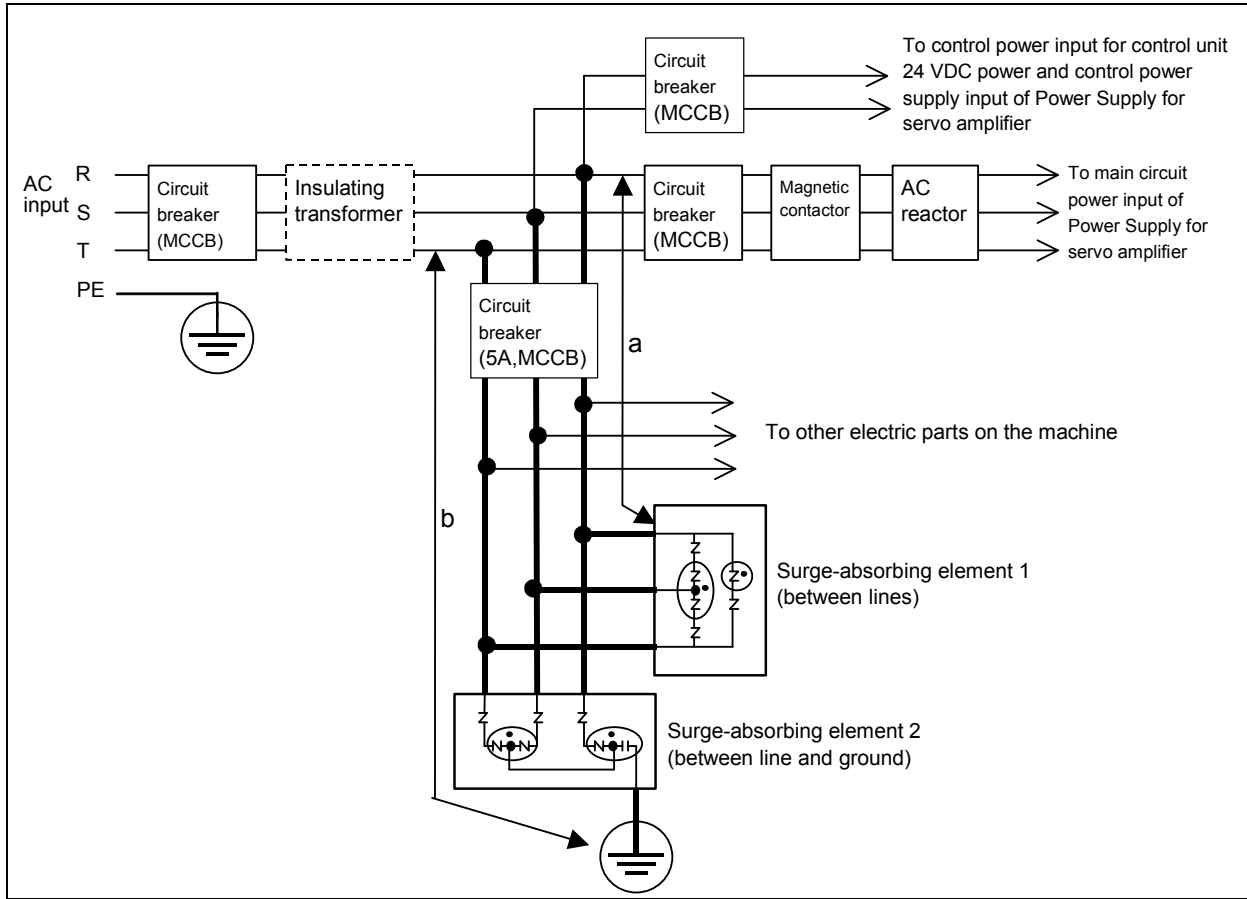

Fig. 2.8.4 Example of installing lightning surge absorbers on 200 VAC lines

### ⚠ CAUTION

- For a better surge absorbing effect, the wiring shown by heavy line must be as short as possible.  
 Wire size : Cross-sectional area at least  $2 \text{ mm}^2$  large  
 Wire length: The sum of the length (a) of the wire for the connection of surge-absorbing element 1 and that (b) of surge-absorbing element 2 must be 2 m or less.
- If conducting dielectric strength tests by applying overvoltages (1000 VAC and 1500 VAC) to the power line, remove surge-absorbing element 2. Otherwise, the overvoltages would activate the element.
- The circuit breaker (5A) is a short circuit protection of lines if the surge-absorbing elements result in short circuit breakdown due to the absorption of an excessive amount of energy.

### NOTE

The circuit breaker (5A) can be used also for other electric parts on the machine because no current flows through surge-absorbing elements 1 and 2 in the normal state. The “other electric parts on the machine” can be the control power supply of Power Supply for servo unit and the power supply for the fan motor for a spindle motor.

# 3 REPLACING CONTROL UNIT MAINTENANCE PARTS

## 3.1 CAUTIONS FOR REPLACEMENT

### WARNING

- 1 Only those personnel who have received approved safety and maintenance training may perform this replacement work. When opening the cabinet and replacing the board, be careful not to touch the high-voltage circuits (marked with  and fitted with an insulating cover). If you touch any uncovered high-voltage circuit, you will get an electric shock.
- 2 Before exchanging, be sure to shut off externally supplied power. Otherwise, electrical shocks, breakdown, and blowout may occur.  
If a control unit is turned off but other units are not, it is likely that power may be supplied to servo units, resulting in the units being damaged and workers getting an electrical shock when the units are exchanged.
- 3 In order to prevent damage that may be caused by static electricity, wear a grounding wrist strap or take a similar protective measure before starting to touch a printed-circuit board or unit or attach a cable.  
Static electricity from human bodies can damage electrical circuits.
- 4 Voltage lingers in servo and spindle amplifiers for a while even after power has been turned off, resulting in workers possibly getting an electrical shock when the workers touch them. Before starting to exchange these amplifiers, wait for 20 minutes after power has been turned off.
- 5 When replacing a unit, ensure that the new unit has the same parameters and settings as the old one. (For details, refer to the manual for the machine.)  
Otherwise, unpredictable machine movement could damage the workpiece or the machine itself or cause injury.
- 6 If you notice an apparent hardware fault, such as abnormal noise, abnormal odor, smoke, ignition, or abnormal heat, in the hardware while power is being supplied to it, shut it off at once. These faults can cause fire, breakdown, blowout, and malfunction.
- 7 The radiating fins of control units, servo amplifiers, spindle amplifiers, and other devices can remain very hot for a while after power has been turned off, making you get burned if you touch them. Before starting to work on them, wait and make sure they are cool.
- 8 When exchanging heavy stuff, you should do so together with two or more people.  
If the replacement is attempted by only one person, the old or new unit could slip and fall, possibly causing injury.
- 9 Be careful not to damage cables. Otherwise, electrical shocks can occur.
- 10 When working, wear suitable clothes with safety taken into account. Otherwise, injury and electrical shocks can occur.
- 11 Do not work with your hands wet. Otherwise, electrical shocks and damage to electrical circuits can occur.

**NOTE**

The LCD (liquid-crystal display) has been fabricated using an extreme precision technology. However, some of their pixels may fail to light or stay constantly lighting because of their characteristics. Please be forewarned that these phenomena are not faults.

### 3.1.1 Optional Information File

This control unit supports the “FANUC Remote Option System”. Optional parameters are held as an optional information file (named “OPRM INF”) in FROM

#### Cautions for optional information file restoration

- 1) When making a backup copy of SRAM data and user files, make a backup copy also of an optional information file (named “OPRM INF”) in FROM. The optional information file is needed when the optional information must be restored, for example, because of it having been damaged.
- 2) Once the optional information file is restored, alarm PS5523 “OPTION AUTHENTICATION WAIT STATE” is issued at power-on, indicating that the optional parameters must be authenticated by the FANUC service department within the period of validity (within 30 days since the occurrence of the alarm). Alarm PS5523 can be canceled by a reset within the period of validity. Contact the FANUC service department for information about the authentication procedure.

### 3.1.2 Attaching and Detaching Units

LCD-mounted type control units, display units, MDI units, and main panel machine operator's panels, can be categorized into two types in terms of the way they are mounted. One of the types is fixed using M4 nuts through the rear surface of the unit, and the other type is fixed using M3 screws through the front surface of the unit. The front surface-mount type units use screw caps for covering the screw holes in its corners.

When attaching the M3-fixed type unit mentioned above to, or detaching it from, a cabinet, follow the procedure below while paying attention to the screw caps.

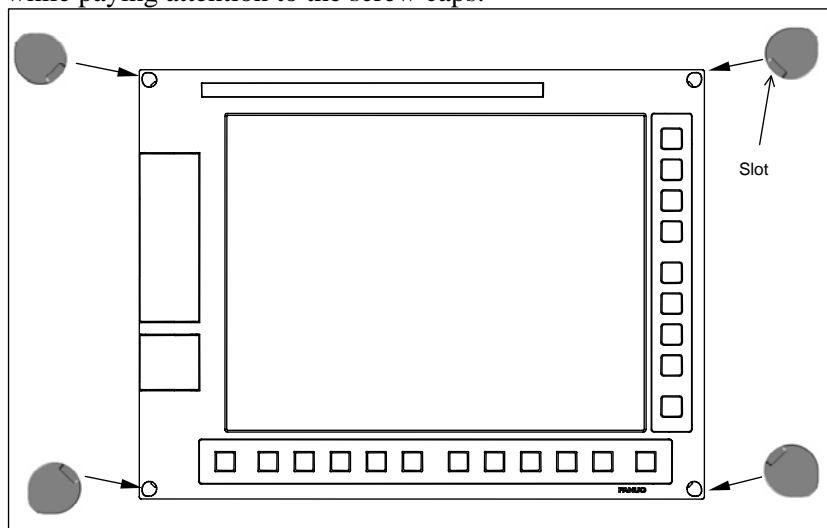

#### Detaching

1. Pull out the screw cap from the screw hole in each corner by inserting a precision screwdriver (flat blade) into the slot in the screw cap head.
2. Remove the screw which appeared each screw cap was detached to detach the unit.

## Attaching

1. Fasten the unit by inserting a screw into the screw hole in each corner. Tighten the screws with an appropriate torque.
2. Cover each screw hole with a screw cap while making sure that all the screw caps are oriented in such a way that their slots face in the respective directions shown in the figure. Push in each screw cap until they become flush with the surface of the unit.

### NOTE

The ordering information for the screw caps is as follows:  
 A02B-0319-K190: A set of 100 screw caps  
 A02B-0319-K191: A set of 5 screw caps

## 3.1.3 Tightening Torque for Fastening Units and Ground Terminals

The following table lists the tightening torque for screws and nuts used to fasten the units (except those having molded mounting parts) explained herein and ground terminals in the units.

Screw and nut diameter	Tightening torque
M3	0.8 to 1.0 N·m
M4	1.6 to 2.0 N·m

The following table lists the tightening torque for screws and nuts used to fasten those units having molded mounting parts, such as stand-alone control units and separate detector interface units.

Screw and nut diameter	Tightening torque
M4	1.1 to 1.5 N·m
M5	2.4 to 2.8 N·m



### CAUTION

Be sure to observe the rules listed above when tightening screws. If screws are tightened too weakly or too strongly, it is likely that the unit may drop, break, or malfunction.

For units having a touch panel in particular, be sure to observe the above rules. Failing to observe them can cause the touch panel to malfunction.

### NOTE

For units having different installation conditions specified herein, observe them first.

## 3.1.4 Packing

Each FANUC-supplied unit, such as a display or operator's panel, has been designed on the assumption that they will be mounted using packing and with the specified screw tightening torque. Failing to mount them as specified can lead to unit damage and/or malfunction. Be sure to use packing and observe the specified screw tightening torque. When replacing the packing, do so neatly so that no coolant will get in the unit after replacement. Observe the following precaution when attaching the packing.

When making screw holes in packing, be careful not to cut to the edge of the packing. Any extra cut can let coolant get in the cabinet through the screw hole, causing trouble.

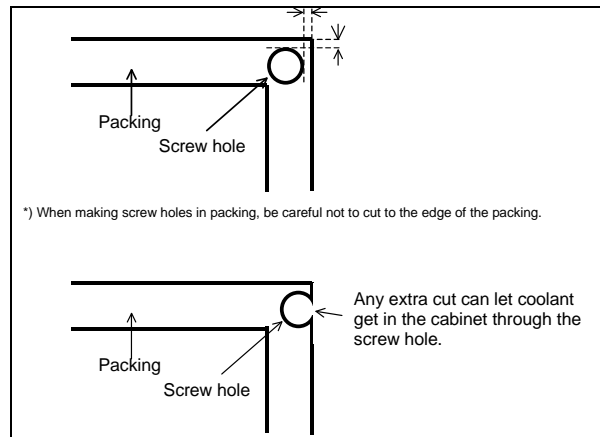

**Packing for LCD units, MDI units, and standard machine operator’s panels**

Observe the following rough standards for the thickness and hardness of packing used with LCD units (included LCD-mounted control units or display units), MDI units, and main panel of standard machine operator’s panel.

- Thickness : 1.4mm(including double-stick tape)
- Hardness : 8(Asker C)

The following models of packing can be purchased from FANUC. These models are electrically conductive. When they are used to mount a unit on a cabinet or pendant box, they leave no electrical gap between the unit and cabinet or pendant box, being effective in electromagnetic wave shielding and EMC measures.

Ordering information	Use
A02B-0323-K302	For 8.4” LCD unit, for standard MDI unit (ONG 8.4” LCD unit)
A02B-0323-K301	For 10.4” LCD unit, for standard MDI unit (ONG vertical type)
A02B-0323-K300	For 12.1” LCD unit
A02B-0323-K304	For 15” LCD unit
A02B-0323-K306	For display unit for automotive manufacture
A02B-0323-K310	For standard MDI unit (ONG vertical type)
A02B-0323-K313	For small MDI unit (ONG 8.4” LCD unit)
A02B-0323-K314	For standard MDI unit (QWERTY)
A02B-0323-K315	For standard MDI unit (QWERTY type B)
A02B-0323-K320	For main panel of standard machine operator’s panel

**⚠ CAUTION**

- 1 We have evaluated the above models of packing for many different coolants. However, we do not necessarily guarantee that they are resistant to all coolants. They are not resistant to, for example, coolants containing sulfur or chlorine at a high activation level and water-soluble coolants at a high alkali level.
- 2 When attaching these models of packing, observe the cautions provided together with them.

When using packing to install a LCD unit, MDI unit, or standard machine operator’s panel in a cabinet or pendant box, be careful not to pinch the packing between the mounting surface of the cabinet or pendant box and the brim of the unit being installed.

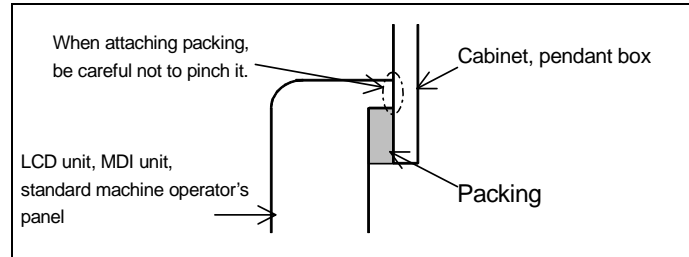

## 3.2 REPLACING THE MAIN BOARD



### CAUTION

Before starting to replace the main board, make a backup copy of the contents (parameters, programs, etc.) of SRAM in the CNC. The SRAM contents may be lost during replacement. See Chapter 5, "INPUT AND OUTPUT OF DATA", and Appendix C, "BOOT SYSTEM" for explanations about how to make backup copies. Also see Subsection 3.1.1, "Optional Information File".

### 3.2.1 LCD-mounted Type Control Unit

#### Replacement procedure

- 1) Remove each cable from the control unit. Take out the control unit from the cabinet while referencing Subsection 3.1.2, "Attaching and Detaching Units".
- 2) Detach the two screws in the lower section of the case unit from the main board. The structure is such that the two screws will not come off the case unit.
- 3) Pull out the case unit while unlatching the claws from the metal bases on both sides in the upper section of the case unit. The case unit comes out together with the back panel, fan motor, and lithium battery.

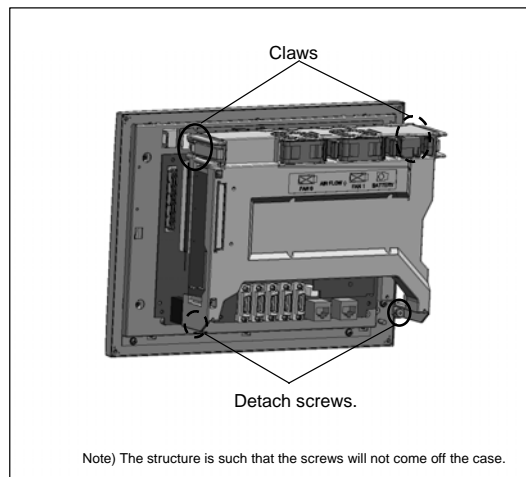

- 4) Remove the cable from each connector on the main board. Also remove the screws fastening the main board.

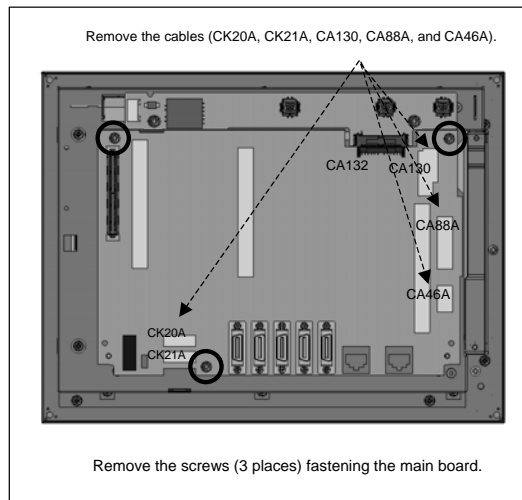

**Detaching the main board from the 10.4" LCD unit-mounted control unit**

- 5) Detach the main board by pulling it down because the main board and inverter board is connected using the connector CA132 (for the inverter board).
- 6) After moving the cards and modules from the detached main board to another (replacing) main board, attach the replacing main board.
- 7) Connect the main board to the inverter board and fasten it with screws. Re-attach each cable to the main board while exercising care not to attach them incorrectly.
- 8) Place the case in such way that its screws and latches align with their positions, and push it in slowly. When pushing it in, make sure that the back panel and main board engage with their respective connectors securely and pay attention not to apply an excessive force. After making sure that the case unit is latched securely, tighten the case unit screws. Also make sure that the fan motor and battery are connected securely.
- 9) While referencing Subsection 3.1.2, "Attaching and Detaching Units", attach the control unit to the cabinet. Re-attach the cables to the control unit. Be careful not to attach them incorrectly.

**NOTE**

Once the main board on a control unit with a touch panel is replaced, the touch panel needs to be calibrated. See Section 3.14 for explanations about how to adjust the touch panel.



## 3.2.2 Stand-alone Type Control Unit

### Replacement procedure

- 1) Remove each cable from the control unit. (The lithium battery need not be removed because it is on the face plate of the main board.)
- 2) Remove the fan unit. <sup>(Caution)</sup>
- 3) Hold handles A and B.
- 4) Pull out the printed circuit board while pushing down the hook of handle A and pushing up the hook of handle B.
- 5) After moving the cards and modules from the detached main board to another (replacing) main board, attach the replacing main board.
- 6) While holding handles A and B, push the main board into the control unit slowly and engage it with the back panel connector. Make sure that the hooks of handles A and B have latched on the case.
- 7) While referencing Subsection 3.11.2, attach the fan unit. Note that, unless the main board is engaged with the back panel securely, the fan unit cannot be mounted.
- 8) Re-attach the cables correctly.

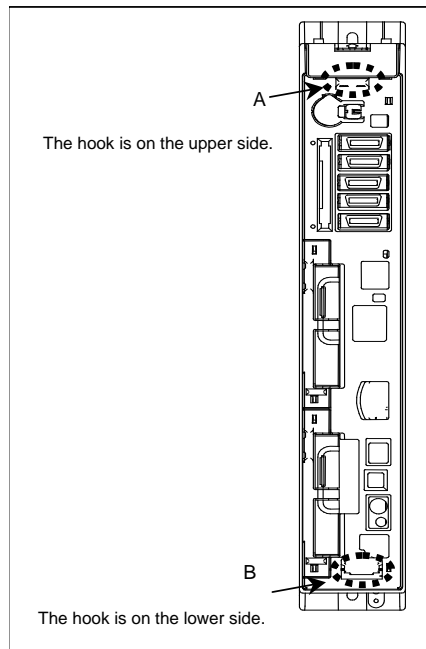

### CAUTION

The main board is so structured that it is fastened to the control unit with the fan unit. For this reason, the main board cannot be detached if the fan unit is mounted on the control unit. Before starting to detach or attach the main board, be sure to remove the fan unit.

See Subsection 3.11.2 for explanations about how to remove the fan unit.

## 3.3 REPLACING THE DISPLAY CONTROL BOARD FOR THE DISPLAY UNIT

### Replacement procedure

- 1) Detach each cable from the display unit. While referencing Subsection 3.1.2, "Attaching and Detaching Units", take out the display unit from the cabinet.
- 2) [Display unit (with 10.4" LCD unit A)]  
Remove the screws from the cover and detach the cover. If the display unit is a type having a touch panel, remove the cable from the touch panel control board before detaching the cover.  
[Other types of display units]  
Remove the two screws from the lower section of the case unit. While pushing down the claws in the upper section, take out the case unit. The structure is such that the screws will not come off the case unit. Note that the fan motor need not be removed. While unlatching the claws from the metal bases on both sides in the upper section of the case unit, pull out the case unit.

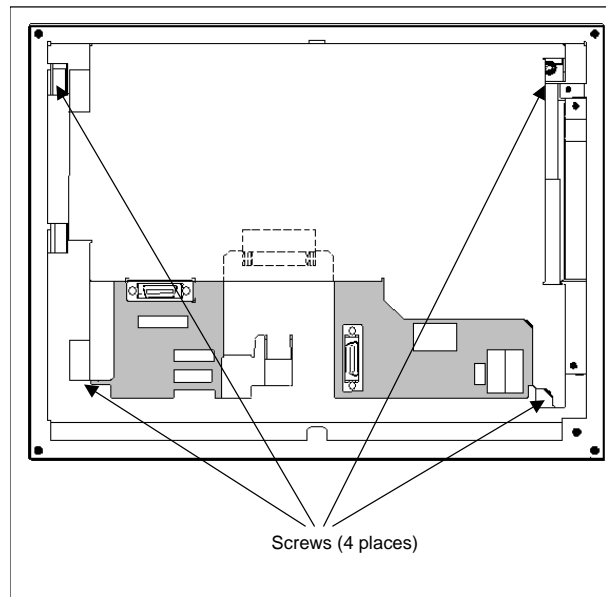

**Display unit (with 10.4" LCD unit A)**

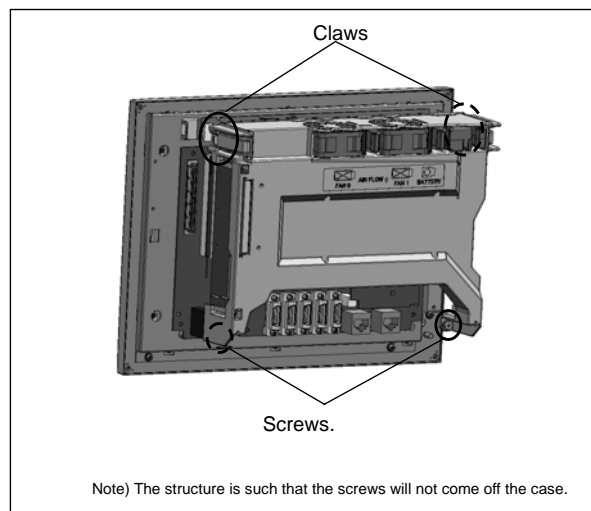

**Other display units**

- 3) Remove the cable from each connector on the display control board. Also remove the screws fastening the display control board.

- 4) Detach the display control board by pulling it down because the display control board and inverter board are connected using the connector CA132 (for the inverter board).
- 5) Move cards and modules (if any) from the detached display control board to another (replacing) display control board, and attach the replacing display control board.
- 6) Connect the display control board to the inverter board and fasten it with screws. Re-attach each cable to the display control board while exercising care not to attach them incorrectly.
- 7) [For display unit (with 10.4" LCD unit A)]  
Mount the cover using screws. If the display unit is a type having a touch panel, re-attach the cable to the touch panel controller board.  
[For other display units]  
Place the case unit in such way that its screws and latches align with their respective positions and push it in slowly. After making sure that the case unit is latched securely, tighten the case unit screws. Also make sure that the fan motor is connected securely.
- 8) While referencing Subsection 3.1.2, "Attaching and Detaching Units", attach the display unit to the cabinet. Re-attach the cables to the display unit. Be careful not to attach them incorrectly.

**NOTE**

Once the display control board on a display unit with a touch panel is replaced, the touch panel needs to be calibrated. See Section 3.14 for explanations about how to adjust the touch panel.

## 3.4 REPLACING LCD UNITS

### 3.4.1 LCD-mounted Type Control Unit (8.4" LCD Unit and 10.4" LCD Unit)

**CAUTION**

Before starting to replace the main board, make a backup copy of the contents (parameters, programs, etc.) of SRAM in the CNC. The SRAM contents may be lost during replacement. See Chapter 5, "INPUT AND OUTPUT OF DATA", and Appendix C, "BOOT SYSTEM" for explanations about how to make backup copies. Also see Subsection 3.1.1, "Optional Information File".

**Replacement procedure**

- 1) Remove the screws from the lower section of the case unit and pull it out while unlatching claws from the upper section.

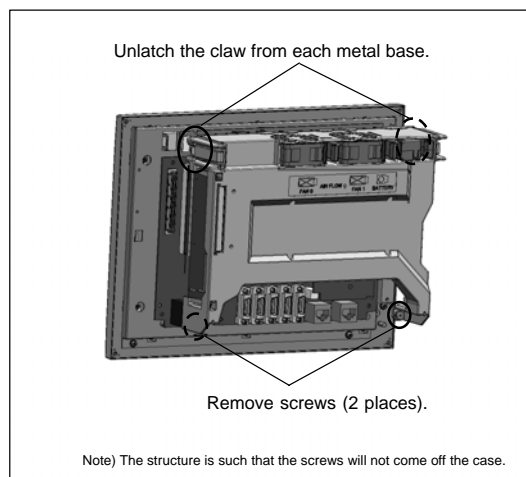

- 2) Detach the cable from each connector on the main board. Also remove the fastening screws.

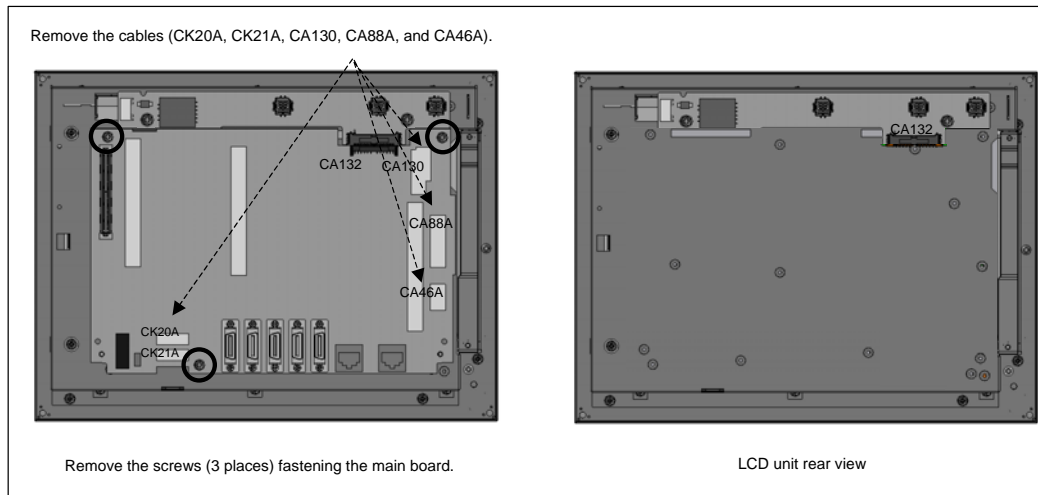

**In case of 10.4" LCD unit A**

- 3) Move the main board to the replacing LCD unit.
- 4) Re-attach the cables, screws, and case unit.

**NOTE**

- 1 See also the descriptions of the main board replacement procedure in Subsection 3.2.1, "LCD-mounted Type Control Unit".
- 2 Once you replace the LCD unit in a control unit with a touch panel, move the touch panel control printed circuit board from the replaced LCD unit to the replacing LCD unit. Note that the touch panel needs to be calibrated. See Section 3.14 for explanations about how to adjust the touch panel.

### 3.4.2 Display Unit for Stand-alone Type Control Unit (10.4" LCD Unit)

#### Replacement procedure

See the descriptions of the display control board replacement procedure for the display unit in Section 3.3.

**NOTE**

Once the LCD unit for a display unit with a touch panel is replaced, the touch panel needs to be calibrated. See Section 3.14 for explanations about how to adjust the touch panel.

## 3.5 MOUNTING AND DEMOUNTING CARD PCBS

### ⚠ CAUTION

Before starting to replace the main board, make a backup copy of the contents (parameters, programs, etc.) of SRAM in the CNC. The SRAM contents may be lost during replacement. See Chapter 5, "INPUT AND OUTPUT OF DATA", and Appendix C, "BOOT SYSTEM" for explanations about how to make backup copies. Also see Subsection 3.1.1, "Optional Information File".

### Method of extraction

1. Unlatch the card PCB (servo card, CPU card, DeviceNet card, or GUI card) by pulling the claws on the two spacers outward. (Fig. a)
2. Pull the card PCB upward. (Fig. b)

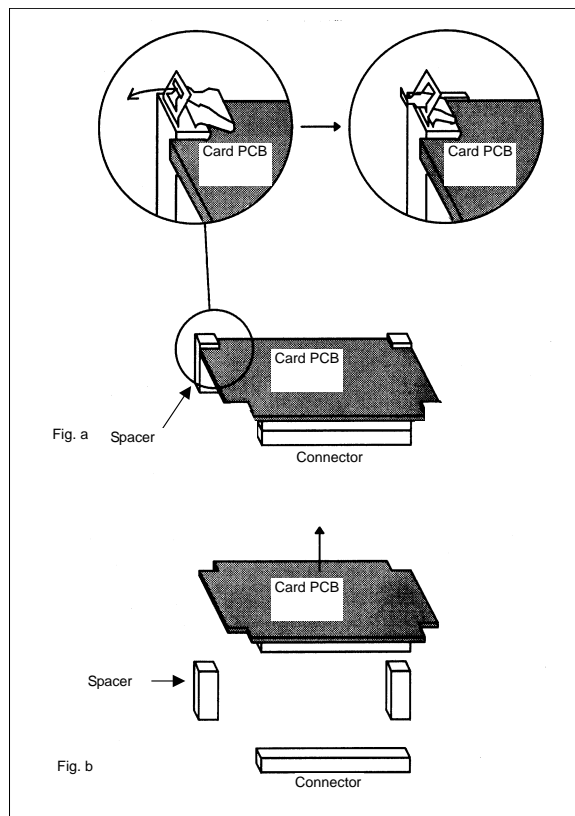

### Method of insertion

1. Check that the metal fittings of the spacers are raised. (Fig. d)
2. To align the card PCB insertion position, touch the spacer fixing end faces of the card PCB with the spacers as shown in the figure below. (At this time, the board can be touched with the spacers for easier position alignment by slightly holding up the connector side and lowering the spacer side only.)
3. While aligning the card PCB with the spacers, lower the connector side slowly then cause the connectors to touch each other. (Fig. d)
4. Push the connector side of the card PCB slowly. At this time, push the card board against the board on the rear side of the connector. The force required for connector insertion is about 10 kgf. If the connector cannot be mated by a force of about 10 kgf or more, the card board may be aligned incorrectly, and the connector can break. In this case, realign the card board.
5. Push in the spacer metal fittings. (Fig. e)

#### CAUTION

When attaching the connector, do not press the radiating fin of the card PCB with your finger, or you may get hurt or the PCB may get damaged.

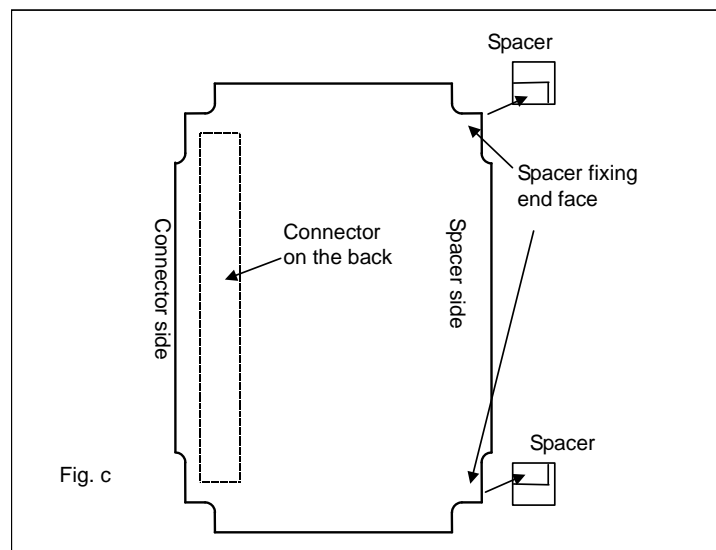
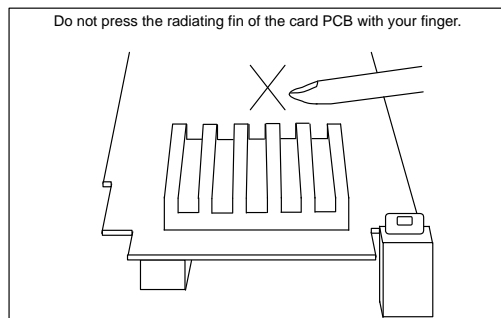

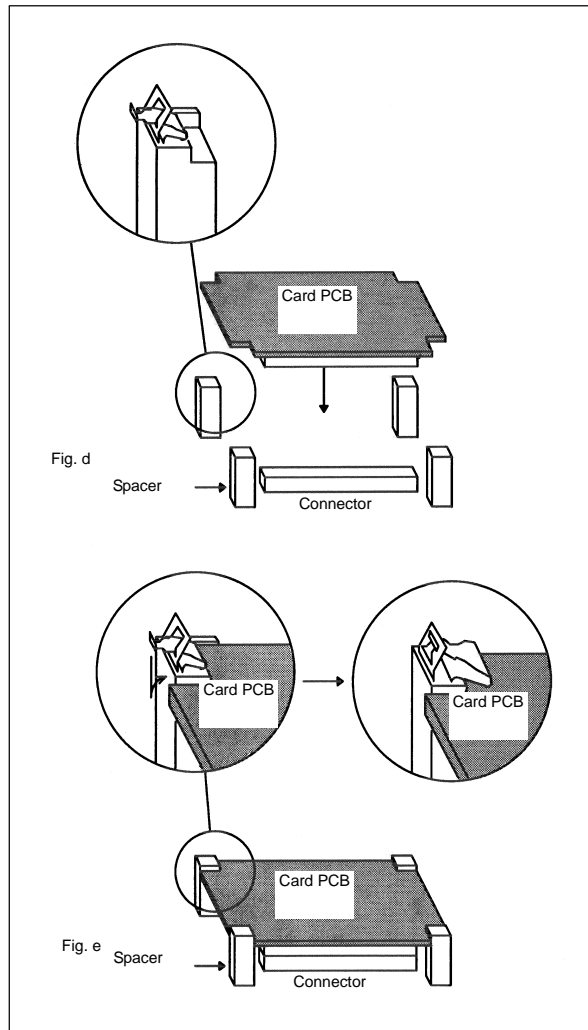

## 3.6 MOUNTING AND DEMOUNTING FROM/SRAM MODULE

### CAUTION

Before starting replacement work, make a backup copy of the contents of the FROM/SRAM module. See Chapter 5, "INPUT AND OUTPUT OF DATA", and Appendix C, "BOOT SYSTEM" for explanations about how to make backup copies and how to restore the contents of memory. Also see Subsection 3.1.1, "Optional Information File" .

### Demounting an FROM/SRAM module

- 1) Open the claw of the socket outward. (Fig. a)
- 2) Extract the module slantly upward. (Fig. b)

### Mounting an FROM/SRAM module

- 1) Insert the module slantly into the module socket, with side B facing upward. (Fig. b)
- 2) Push the module downward until it is locked. (Fig. c) At this time, push it down with pushing two points of (\*) in the figure.

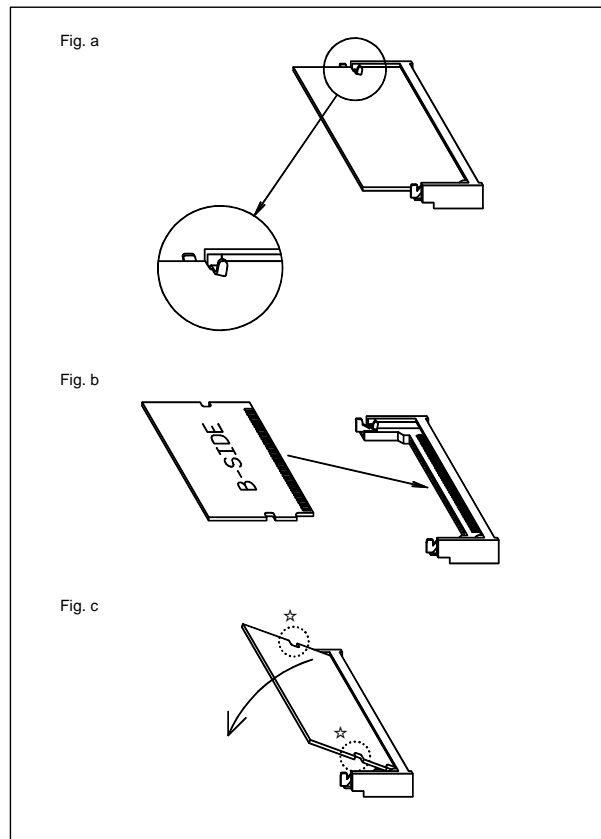

### 3.7 ATTACHING A COMPACT FLASH CARD ONTO, AND DETACHING IT FROM, A PRINTED CIRCUIT BOARD



#### CAUTION

Before starting to replace the compact flash card, make a backup copy of the contents (parameters, programs, etc.) of SRAM in the CNC. The SRAM contents may be lost during replacement. See Chapter 5, "INPUT AND OUTPUT OF DATA", and Appendix C, "BOOT SYSTEM" for explanations about how to make backup copies. Also see Subsection 3.1.1, "Optional Information File".

Some types of printed circuit boards incorporate a compact flash card. When replacing these printed circuit boards, stick to the following procedures.

#### Dismounting procedure

Pull out the card by turning the latch toward the far side while pressing down the printed circuit board retainer gently.

#### Mounting procedure

Push in the card until it locks.



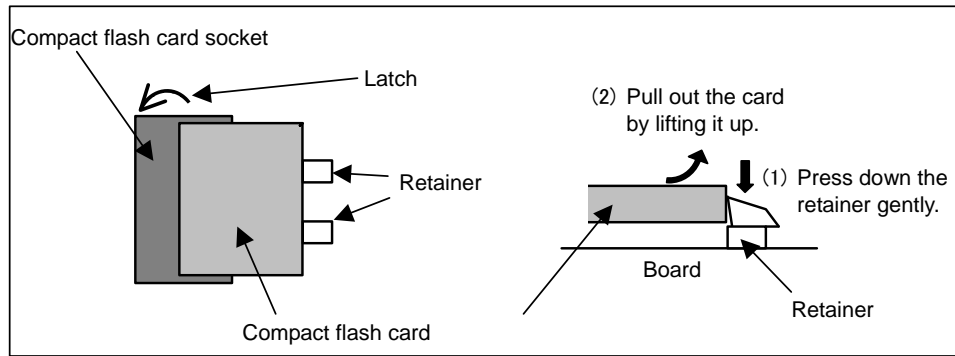

## 3.8 INSERTING AND EXTRACTING OPTIONAL BOARDS

### Method of extraction

1. Detach the cable connected to the optional board and the cable that interferes when the optional board is extracted.
2. Pinch handles A and B.
3. Pinch handle A, and extract the optional board while disengaging the latch.

### Method of insertion



#### CAUTION

Insert the option board all the way through the rack. Turning on the power without having it engaged with the back panel connector on the far-side wall of the rack may lead to a failure or system alarm.

1. By holding handles A and B, insert the board into the rack until it reaches the far-side wall of the rack to make the back panel engaged with the connector. Make sure that the claw of handle A is latched securely and the option board surface is flushed with the ambient surface.
2. Plug the detached cables again correctly.

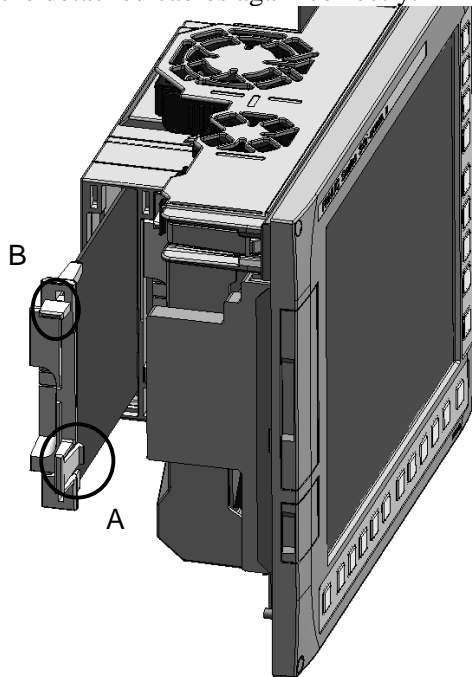

LCD-mounted type

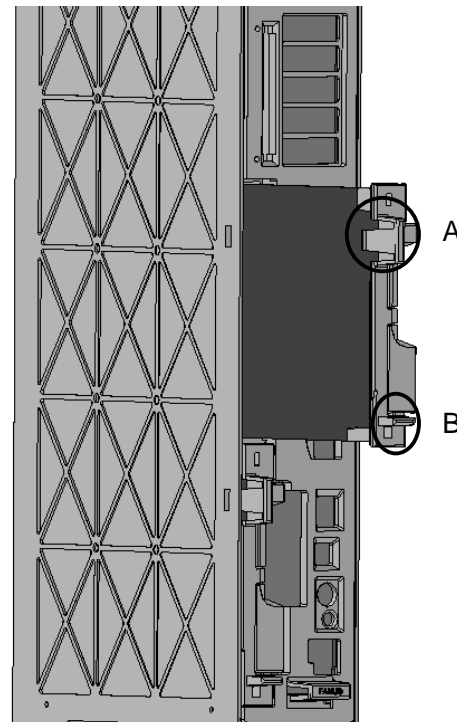

Stand-alone type

**Option board location**

Which slot is to be used for which option board is predetermined. When adding or maintaining option boards, install them while observing the following rules.

1. Option boards for 2-slot type LCD-mounted or stand-alone control units  
 Check the option boards you are going to install with Table 3.8.1. Insert a board with a smaller number and that with a larger number, respectively, into slots 1 and 2.
2. Option boards for 4-slot type stand-alone control units  
 Check the option boards you are going to install with Table 3.8.1. Insert a board with the smaller number, one with the next smaller number, and so, respectively, into slots 1, 3, 4, and 2 in the stated order.

**Table 3.8.1 Optional boards**

No.	Name
1	PROFIBUS-DP master board
2	Fast Ethernet board
3	DeviceNet master board
4	DeviceNet slave board
5	PROFIBUS-DP slave board
6	HSSB board
7	CC-Link remote device station board
8	Additional axis board

LCD-mounted type

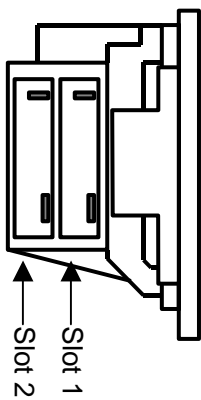

Stand-alone type

4 slots

2 slots

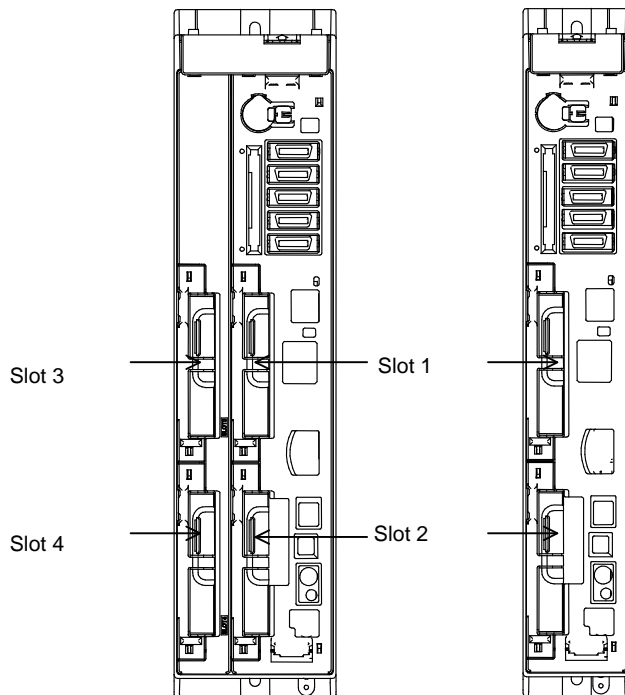

## 3.9 REPLACING FUSES

---



### **WARNING**

Before replacement of a blown fuse, the cause of the blown fuse must be corrected. So, fuse replacement work must be done only by a person who is trained in the related maintenance and safety requirements. When opening the cabinet and replacing a fuse inside, be careful not to touch the high-voltage circuits (marked with  and fitted with an insulating cover). Touching the uncovered high-voltage circuits presents an extremely dangerous electric shock hazard.

### 3.9.1 LCD-mounted Type Control Unit

• **8.4” LCD unit and 10.4” LCD unit A**

Fuse mounting location

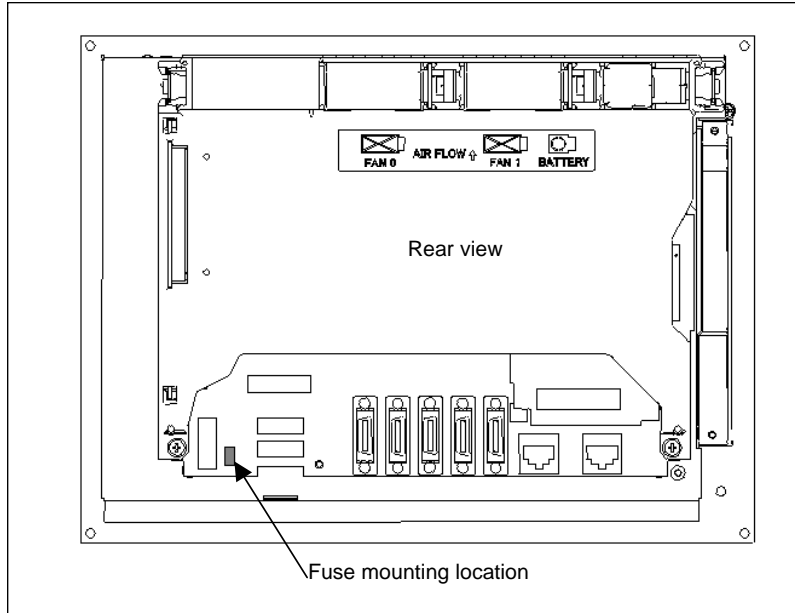

Fuse specification

Specification	Rating
A02B-0236-K100	5A

• **10.4” LCD unit and 15” LCD unit**

Fuse mounting location

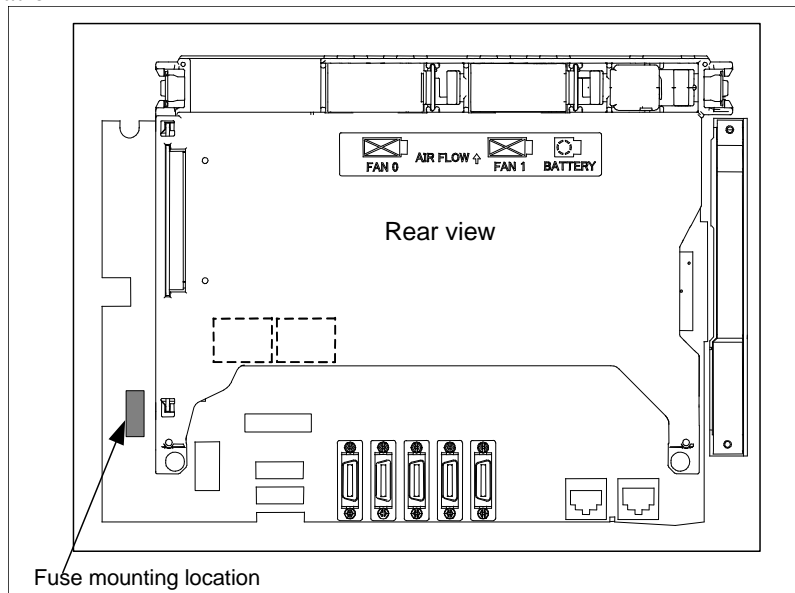

Fuse specification

Specification	Rating
A02B-0236-K101	7.5A

### 3.9.2 LCD-mounted Type Control Unit (Personal Computer Function with Windows® CE)

Fuse mounting location

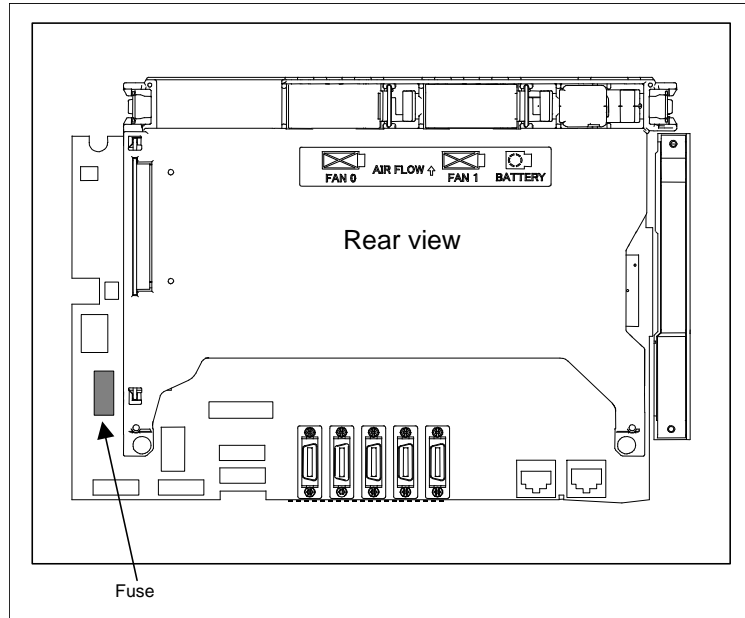

Fuse specification

Specification	Rating
A02B-0236-K101	7.5A

### 3.9.3 Stand-alone Type Control Unit

Fuse mounting location

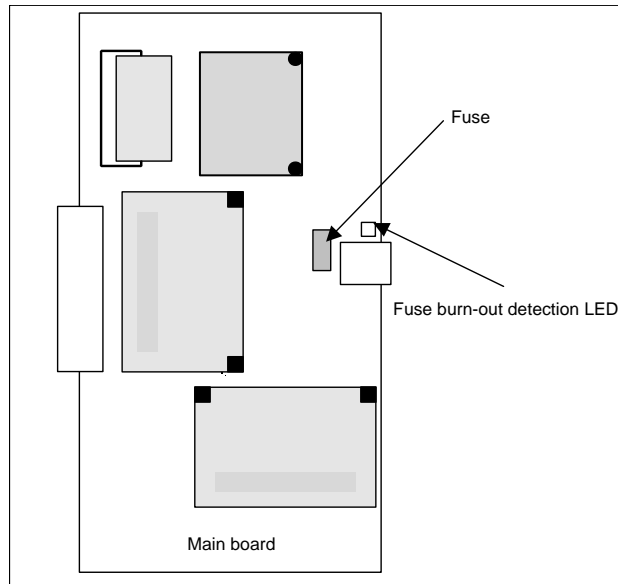

The fuse is on the main board. Before replacing the fuse, pull out the main board. See Subsection 3.2.2 for explanations about how to pull it out.

Fuse specification

Specification	Rating
A02B-0265-K100	7.5A

### 3.9.4 Display Unit for Stand-alone Type Control Unit

#### 3.9.4.1 Display unit (10.4" LCD unit A)

Fuse mounting location

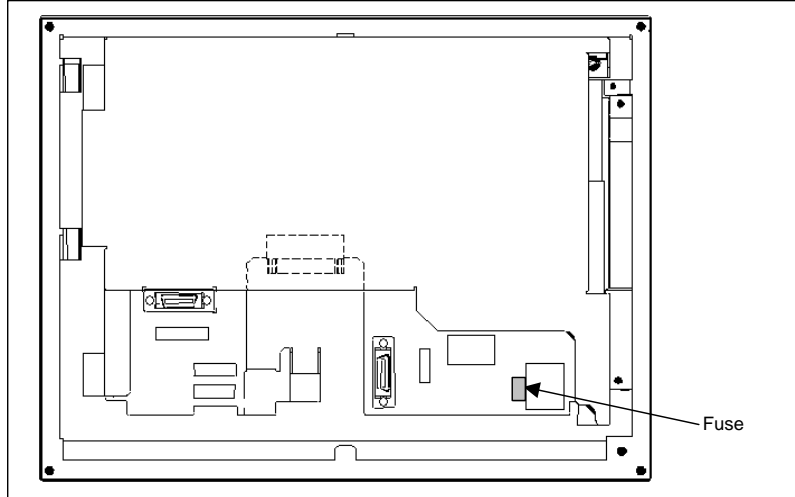

Fuse specification

Specification	Rating
A02B-0303-K101	3.2A

#### 3.9.4.2 Display unit (10.4" LCD unit B and 15" LCD unit)

Fuse mounting location

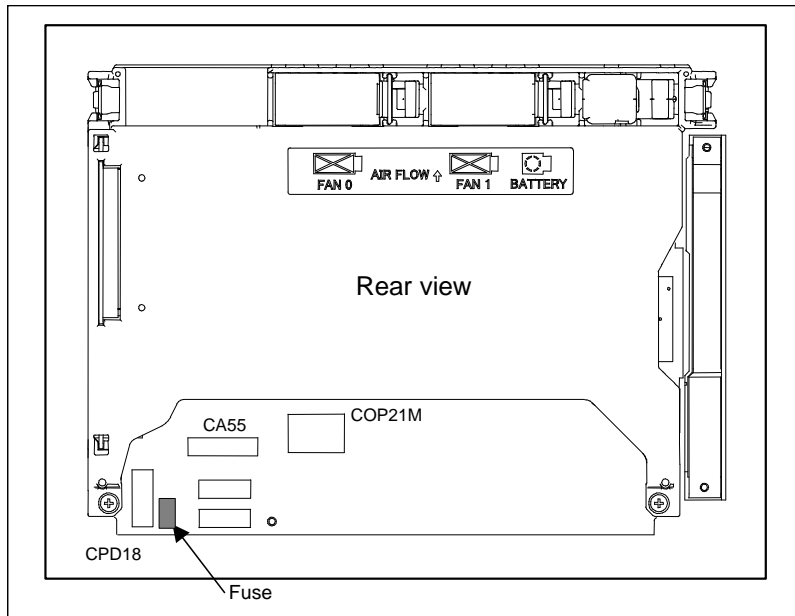

Fuse specification

Specification	Rating
A02B-0236-K100	5A

### 3.9.4.3 Display unit for Automotive manufacture

Fuse mounting location

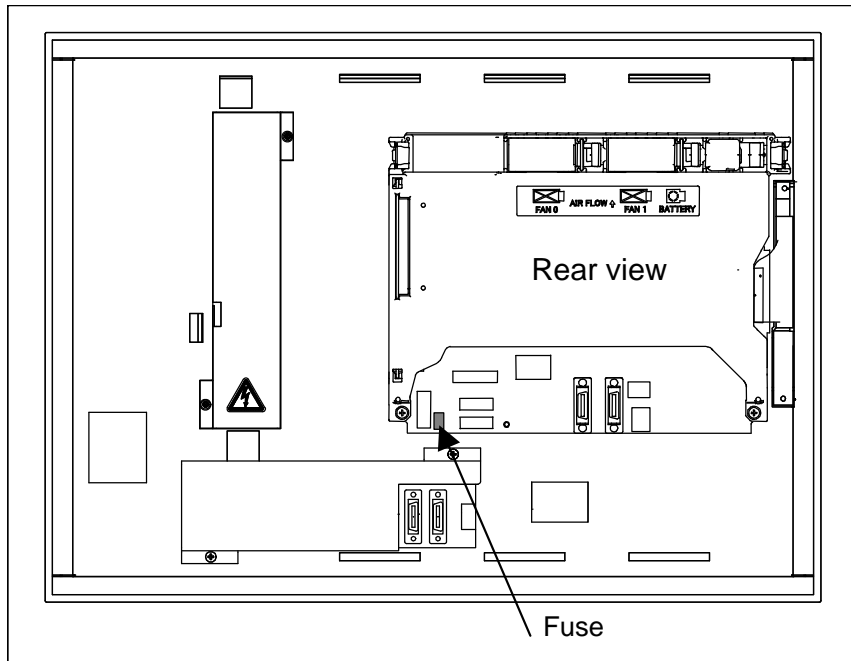

Fuse specification

Specification	Rating
A02B-0236-K100	5A

### 3.9.5 Replacing the Fuse on the Display Unit for the Stand-Alone Type Control Unit (with PC Functions Supporting Windows® CE)

Fuse mounting location

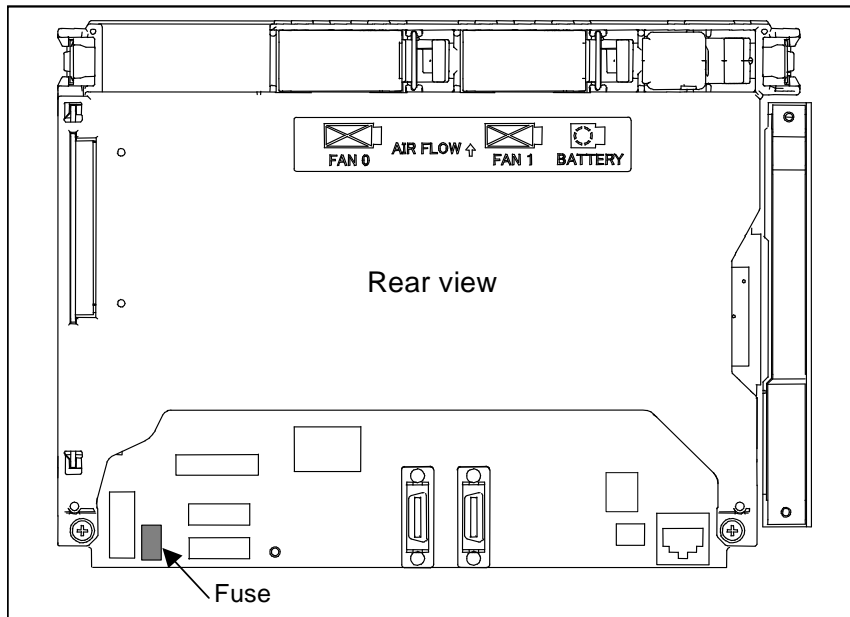

Fuse specification

Specification	Rating
A02B-0236-K100	5A

## 3.10 REPLACING THE MEMORY BACKUP BATTERY IN THE CONTROL UNIT

Such as Offset data and system parameters are stored in SRAM in the control unit. The power for the SRAM is backed up with a memory backup battery housed in the control unit. Therefore, the above data is not lost even if the main power is turned off.

When the battery voltage falls, alarm message "BAT" blinks on the LCD screen and the battery alarm signal is output to the PMC. Once the alarm message starts blinking or the alarm signal is output, replace the battery as soon as possible. In general, the battery can be replaced within one week of the alarm first being issued. This, however, depends on the system configuration.

If the battery voltage subsequently drops further, backup of memory can no longer be provided. Turning on the power to the control unit in this state causes system alarm to be issued because the contents of memory are lost. Replace the battery, clear the entire memory, then reenter the data.

For this reason, FANUC recommends that the battery be replaced once per year regardless of whether a battery alarm is issued.

Two types of batteries are usable:

- Lithium battery incorporated in the control unit
- Commercial alkaline dry cells (R20) inserted in a battery case externally attached to the control unit

### NOTE

The control unit is factory-equipped with a lithium battery by default. This battery can provide backup for the memory contents for about a year.

### 3.10.1 Replacing a Lithium Battery

#### For LCD-mounted type control unit

Prepare a new lithium battery (ordering code: A02B-0323-K102).

- <1> Turn the power to the machine (control unit) on. After about 30 seconds, turn the power off.
- <2> Pull out the lithium battery on the back of the control unit. (Hold the latch of the lithium battery, and pull the lithium battery toward you while releasing the claw from the case.)

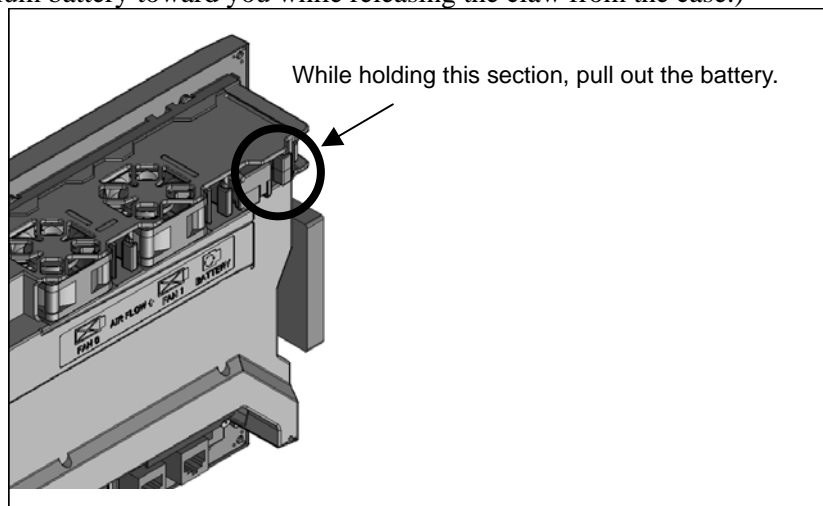

- <3> Mount a new lithium battery you get ready beforehand. (Push the battery until the catch is latched with the case.) Confirm that the catch has been latched securely.



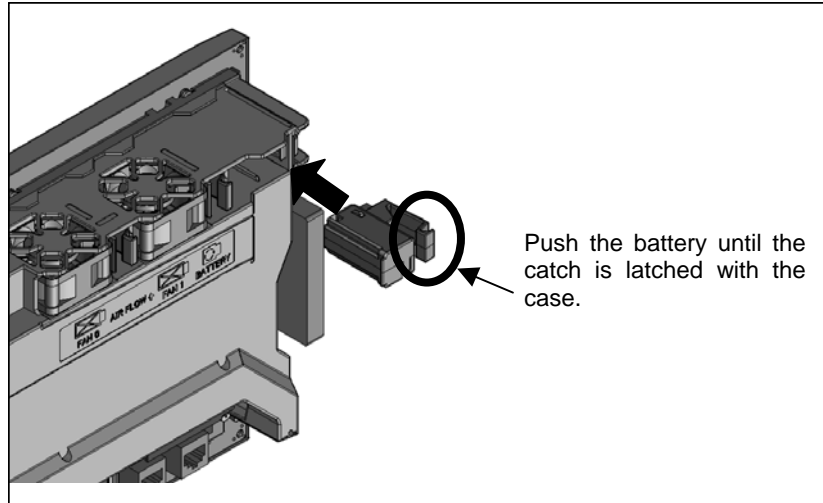

**⚠ WARNING**

Using other than the recommended lithium battery may result in the battery exploding. Replace the battery only with the specified lithium battery (A02B-0323-K102).

**⚠ CAUTION**

Steps <1> to <3> should be completed within 30 minutes.  
Do not leave the control unit without a battery for any longer than the specified period. Otherwise, the contents of SRAM may be lost.  
Before starting replacement work, save the contents of the SRAM in a batch. Even if they are lost, they can be restored easily.  
For the methods of saving all contents and restoring them, refer to the Chapter 5, "INPUT AND OUTPUT OF DATA", and Appendix C, "BOOT SYSTEM".

**NOTE**

After replacement, dispose the used battery as "industrial waste" correctly according to the laws of the country where the machine is installed and the ordinances of the local government having jurisdiction over the site of the machine. When disposing the battery, insulate it, for example, by taping its electrodes in order to prevent a short circuit.

**For stand-alone type control unit**

Prepare a new lithium battery (ordering code: A02B-0200-K102).

- <1> Turn the power to the machine (control unit) on. After about 30 seconds, turn the power off.
- <2> Remove the lithium battery on the upper section of the control unit.  
First, unplug the connector by yanking the battery cable, then take the battery out of its case.  
The battery case is located in the upper section of the face plate of the main board.
- <3> Insert a new lithium battery and reconnect the connector.

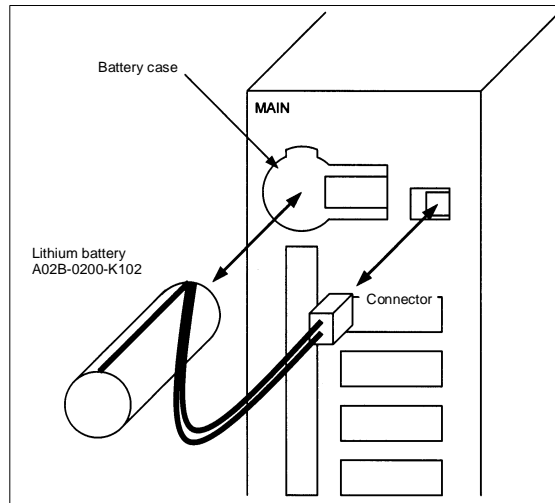
**⚠ WARNING**

Using other than the recommended battery may result in the battery exploding. Replace the battery only with the specified battery (A02B-0200-K102).

**⚠ CAUTION**

Steps <1> to <3> should be completed within 30 minutes. Do not leave the control unit without a battery for any longer than the specified period. Otherwise, the contents of SRAM may be lost. Before starting replacement work, save the contents of the SRAM in a batch. Even if they are lost, they can be restored easily. For the methods of saving all contents and restoring them, refer to the Chapter 5, "INPUT AND OUTPUT OF DATA", and Appendix C, "BOOT SYSTEM".

**NOTE**

After replacement, dispose the used battery as "industrial waste" correctly according to the laws of the country where the machine is installed and the ordinances of the local government having jurisdiction over the site of the machine. When disposing the battery, insulate it, for example, by taping its electrodes in order to prevent a short circuit.

### 3.10.2 Replacing a Commercial D-size Alkaline Dry Cells

Commercial alkaline dry cells (R20) can be used in place of the lithium battery incorporated in the control unit by inserting them in a battery case externally attached to the control unit.

#### How to connect the battery case to the control unit

For the LCD-mounted type control unit, attach a battery cable (A02B-0323-K103) to the battery case (A02B-0236-C282). For the stand-alone control unit, use the battery case (A02B-0236-C281), which is factory-attached with a battery cable.

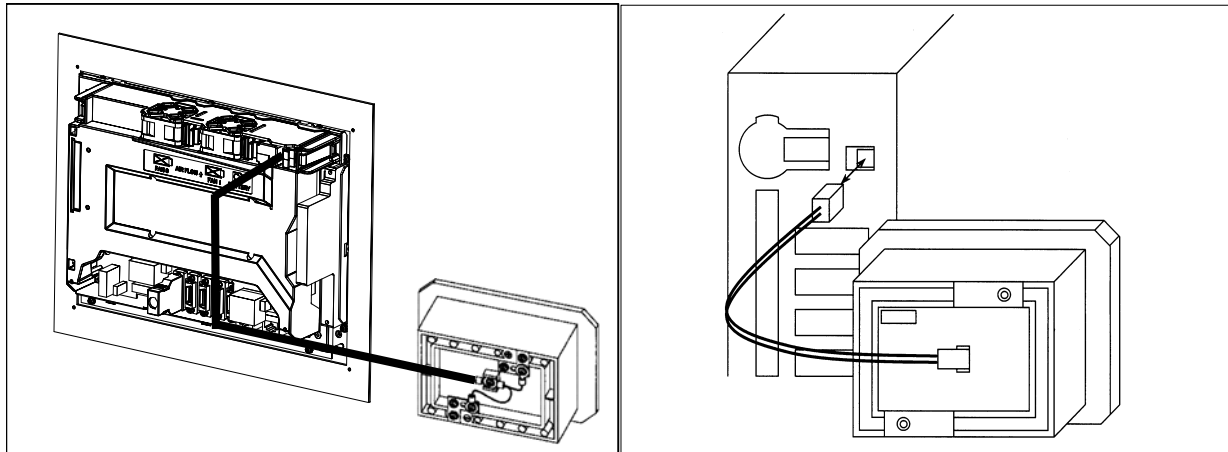

(For LCD-mounted type)

(For stand-alone type)

Example of connecting the battery case to the control unit

#### NOTE

- 1 The connector of the battery cable has a simplified lock for engagement. So, fix the battery cable at a point within a length of 500 mm from the connector location with no tension on it in order to prevent the connector from falling due to its own weight or any extraneous force.
- 2 Keep the battery cable away from any source of noise, such as power wires.

#### Replacing a commercial D-size alkaline dry cells

- <1> Have commercial D-size alkaline dry cells handy.
- <2> Turn the power to the machine (control unit) on for about 30 seconds.
- <3> Turn off the power to the control unit.
- <4> Remove the cover from the battery case.
- <5> Replace the old dry cells with new ones. Mount the dry cells in a correct orientation.
- <6> Reinstall the cover onto the battery case.

#### ⚠ CAUTION

Steps <1> to <6> should be completed within 30 minutes.

Do not leave the control unit without a battery for any longer than the specified period. Otherwise, the contents of SRAM may be lost.

If steps <1> to <6> may not be completed within 30 minutes, save all contents of the SRAM to the memory card or USB memory beforehand. Thus, if the contents of the SRAM are lost, the contents can be restored easily.

For the methods of saving all contents and restoring them, refer to the Chapter 5, "INPUT AND OUTPUT OF DATA", and Appendix C, "BOOT SYSTEM".

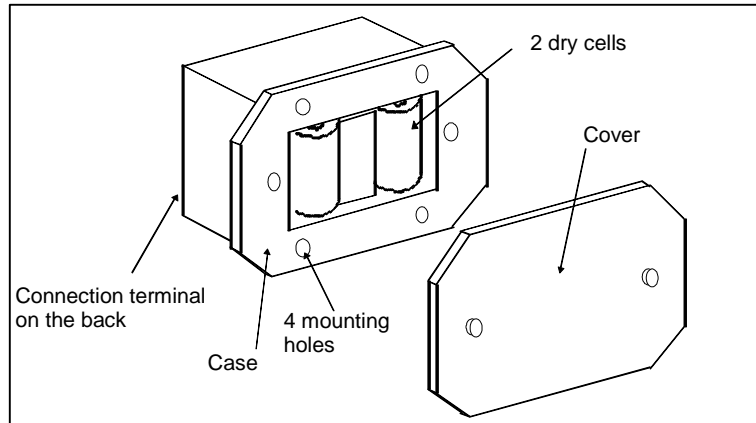

### 3.11 REPLACING A FAN

When a reduction in the speed of the fan motor is detected, the FAN warning message blinks on the LCD screen.

When a failure such as stop of the fan motor is detected, an overheat alarm or system alarm is issued and the system stops operating. Therefore, as soon as the FAN warning appears, replace the fan motor.

#### 3.11.1 LCD-mounted Type Control Unit

**- Fan motor specification**

	Specification	Remark
Unit with no option slot	A02B-0323-K120	
Unit with a slot for option 1	A02B-0323-K124	
Unit with a slot for option 2	A02B-0323-K125	

**- Replacing a fan motor**

1. When replacing the fan motor, be sure to turn off the power to the machine (CNC).
2. Remove the fan motor from the case by holding its latch and pulling it out while releasing the claws from the case.
3. Mount the fan motor to the case. After that, make sure that the fan motor claws have latched the case securely.

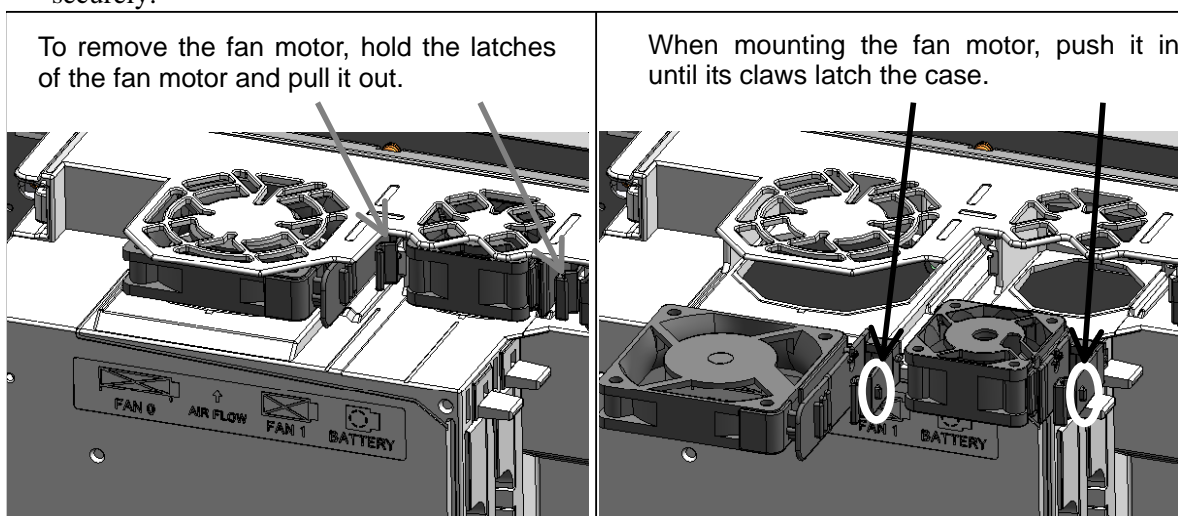

## 3.11.2 Stand-alone Type Control Unit

### - Fan unit specification

	Specification	Remark
2-slot rack fan unit	A02B-0303-C103	
4-slot rack fan unit	A02B-0303-C102	

### - Replacing a fan unit

#### Detaching a fan unit

1. When replacing the fan motor, be sure to turn off the power to the machine (control unit).
2. Push up the latch at the top of the unit until the latch is disengaged.

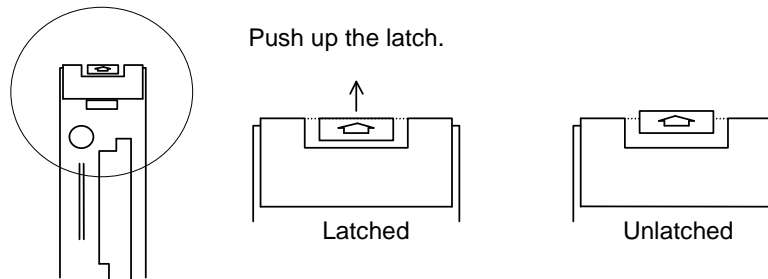

#### **CAUTION**

Just disengage the latch. Do not push up the latch after the latch is disengaged. If you continue pushing up the latch forcibly, the latch can break.

3. Place a finger at the bottom of the front of the fan unit then push up the fan unit.

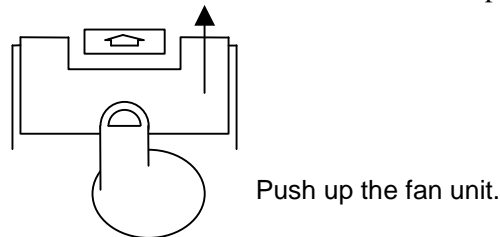

4. Push up the fan unit until the fan unit is slanted by about 30 degrees.
5. Pull out the fan unit toward you in the slanted direction.

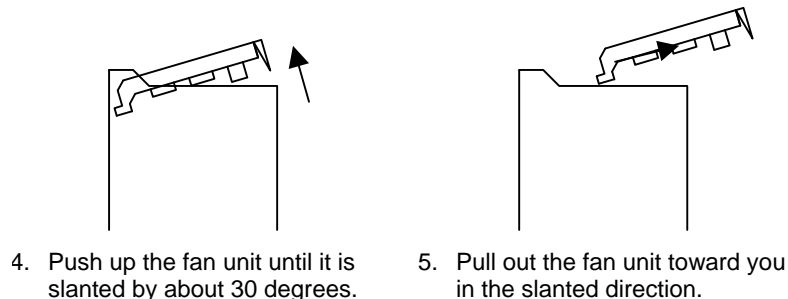

#### Attaching a fan unit

1. Insert a fan unit deeply into the main unit at a slanted angle of about 30 degrees until the fan unit touches the wall of the main unit.
2. Lower the fan unit slowly on the main unit.
3. Push down the fan unit on the near side to couple the fan unit with the top of the main unit.

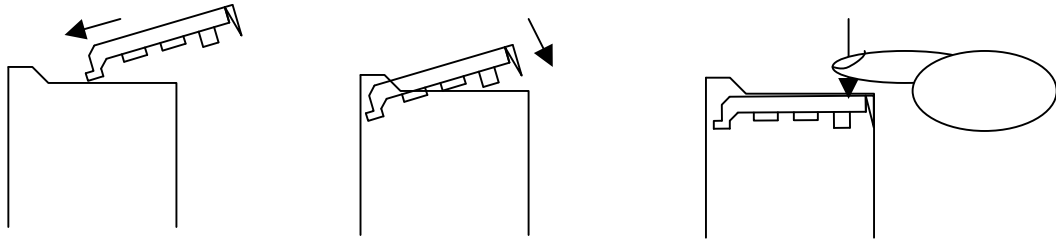

1. Insert the fan unit at about 30 degrees until it touches the far-side wall of the main unit.
2. Lower the fan unit slowly.
3. Push down the fan unit to connect it to the main unit.

**CAUTION**  
 The fan unit and main board are coupled directly with each other by a connector. When mounting the fan unit, failing to follow the connection procedure correctly may damage the coupling section of the connector.

4. Push down the latch at the top of the fan unit for latching.

4. Push down the latch.

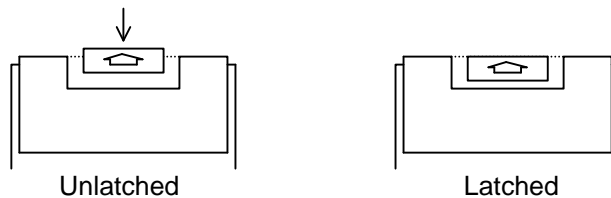

5. Turn on the power, then check that no fan alarm is issued and that both fans are rotating.

**CAUTION**  
 If the power is turned on without connecting the fan unit correctly, it is likely that the fan may not be able to rotate or a fan alarm may be issued even when it rotates. After replacement, make sure that the fan rotates normally and no fan alarm is issued.

**NOTE**  
 When a large amount of force is required to couple the fan unit with the main unit, check if pins of the connector of the base printed circuit board are bent and if the base printed circuit board is inserted correctly.

### 3.11.3 Display Unit for Automotive

**- Fan motor specification**

Specification	Remark
A02B-0323-K120	

**- Replacing a fan motor**

See Subsection 3.11.1 for explanations about how to replace the fan motor.

### 3.11.4 Display Unit for Stand-alone Type Control Unit (Personal Computer Function with Windows® CE)

- **Fan motor specification**

Specification	Remark
A02B-0323-K120	

- **Replacing a fan motor**

See Subsection 3.11.1 for explanations about how to replace the fan motor.

## 3.12 REPLACING THE PROTECTION COVER

### - Protection cover specification

Screen size	Specification	Remark
8.4"	A02B-0323-K112	
10.4"	A02B-0323-K113	
12.1"	A02B-0323-K114	
15"	A02B-0323-K115	

### - How to attach the protection cover

If the screen surface already has a protection cover or touch panel protection sheet attached on it, detach the cover or sheet from it. Remove any adhesive left on it completely, using adhesive tape. Using solvent in attempt to remove any remaining adhesive may result in the screen surface being soiled contrary to your expectation.

Before attaching the protection cover, wipe off any soil and smear completely from the ornamental frame, LCD surface, and soft key surface, using ethanol or diluted neutral detergent (such as kitchen detergent). If you used neutral detergent, remove any remaining detergent, using a cloth wetted with water. Any remaining oily substance or detergent causes the protection cover to come off easily. After making sure that the ornamental frame is dry, follow the procedure below to attach the protection cover.

#### - For 8.4" LCD unit

1. Position the protection cover in such a way that the both-side adhesive tape does not overlap with the soft key section, LCD section, PCMCIA interface or USB port lids.
2. Upon completion of positioning, press the protection cover by stroking the both-side adhesive tape section. Moving your finger along the attached surface with a short reciprocating motion can enhance adhesion.
3. The protection cover surface is covered with a thin film to protect it from flaws and contamination. Peel off the thin film from the protection cover.

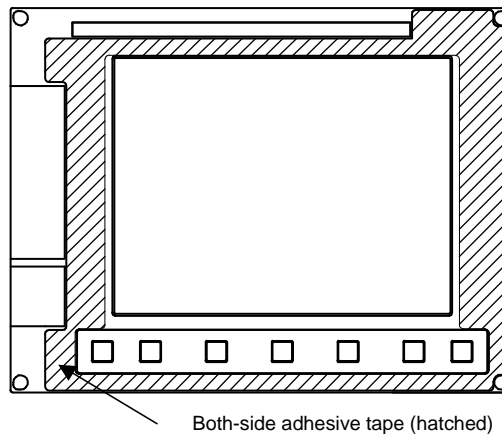

#### - For 10.4", 12.1", and 15" LCD units

1. The protection cover for the LCD units has a concave section so that it is conformable to the figure of the display section. Position the protection cover in such a way that the concave section meets the ornamental frame at the position indicated with the arrow while exercising care not to cause the both-side adhesive tape to overlap with the soft key section.
2. Pressing the protection cover after positioning in such a way that any air left between the LCD section and protection cover is expelled toward the right will make it possible to attach the protection cover tidily. Once the protection cover is finally positioned, press it firmly while stroking the both-side adhesive tape section. Moving your finger along the attached surface with a short reciprocating motion can enhance adhesion.



3. For units with a touch panel, make sure that the touch panel is not held pressed after power-on. Also make sure that the touch panel works normally.

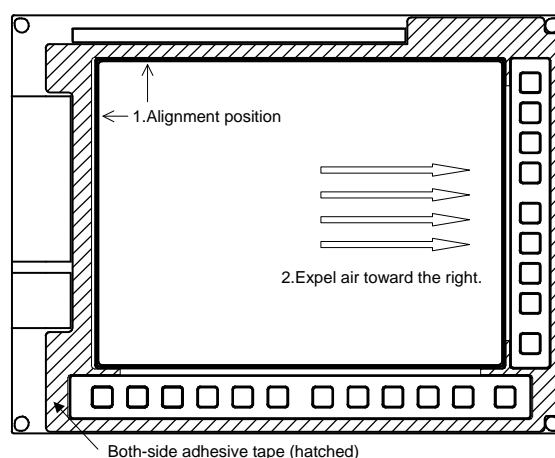

### 3.13 REPLACING THE TOUCH PANEL PROTECTION SHEET

For the unit with a touch panel, the surface of the touch panel is covered with the protection sheet to protect it. When there are flaws and contamination on this protection sheet that make the screen hard to read, replace the protection sheet. Prepare the following items.

- 1) Protection sheet
- 2) Ethanol or neutral detergent (such as kitchen detergent)
- 3) Soft cloth (if neutral detergent is used)

#### Touch panel protection sheet specification

Screen size	Specification	Remark
10.4"	A02B-0236-K110	
12.1"	A02B-0236-K118	
15"	A08B-0082-K020	

#### - Replacement procedure

- 1) Before replacement
  - <1> Turn off the power to the machine.
  - <2> Peel off the old protection sheet from the surface of the touch panel.
  - <3> Remove any remaining adhesive completely, using adhesive tape.  
Using solvent in attempt to remove any remaining adhesive may result in the screen surface being soiled contrary to your expectation.
  - <4> Remove any oily substance from the touch panel surface, using ethanol or diluted neutral detergent.
  - <5> If you used neutral detergent, remove any remaining detergent, using a soft cloth wetted with water.
    - If the touch panel surface becomes cloudy, oil is still left on the surface. Remove oil completely.
    - If oil or detergent is left on the surface of the touch panel, the protection sheet cannot adhere to the panel completely and will sometimes peel off easily.
  - <6> With a dry soft cloth, wipe off moisture completely.

- 2) Applying the protection sheet
  - <1> Fold the tab over the front side (the side opposite to the backing sheet).

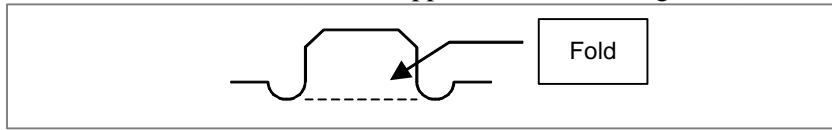

- <2> Peel off the backing sheet.
  - <3> Position the sheet, then attach the upper and lower sides of the sheet first. Check that the sides of the protection sheet do not touch the escutcheon.

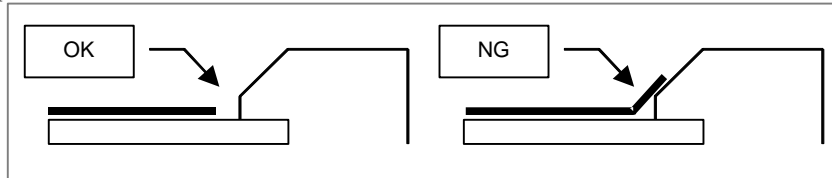

- <4> Attach the right and left sides of the protection sheet while pushing out air between the touch panel and protection sheet.
    - With part of the protection sheet kept stuck to the touch panel, do not attempt to correct the position of the protection sheet by pulling the sheet.
  - <5> Press the adhesive parts of the four sides, and attach the entire sheet completely.
    - Check that the four corners and four sides of the protection sheet do not float.

- (3) Checks after replacement
  - <1> Check that there is no wrinkle on the surface of the protection sheet.
  - <2> After power-on, check that there is no touch panel portion kept pressed.
  - <3> Press the touch panel, and check that correct operation takes place.

## 3.14 TOUCH PANEL CALIBRATION

### - Conditions that require calibration

Touch panel calibration is needed under the following conditions:

1. The LCD mounted type control unit with a touch panel or the display unit with a touch panel was replaced.
2. The main board on the LCD mounted type control unit with a touch panel or the display control board on the display unit with a touch panel was replaced.
3. The touch panel control board was replaced.
4. Memory all clear was performed.

### - Related Parameters

	#7	#6	#5	#4	#3	#2	#1	#0
3113			DCL					

[Input type] Parameter input

[Data type] Bit

**#5 DCL** The touch panel compensation screen is:

0: Disabled.

1: Enabled.

Set this parameter to 0 usually. Touch panel compensation becomes necessary only when the panel is replaced or memory all clear operation is performed. Set this parameter to 1 only when performing touch panel compensation. Upon completion of compensation, set this parameter to 0.

	#7	#6	#5	#4	#3	#2	#1	#0
3119					TPA	DDS		

[Input type] Parameter input  
 [Data type] Bit



**NOTE**  
 When this parameter is set, the power must be turned off before operation is continued.

**#2 DDS** The touch panel is:  
 0: Enabled.  
 1: Disabled.  
 Set this parameter to 1 when disabling the touch panel temporarily, for example, at start-up time.

**- Touch panel calibration method**

**NOTE**  
 How to calibrate the touch panel used with the display unit for the LCD-mounted control unit (with personal computer function with Windows® CE) and the stand-alone control unit (with personal computer function with Windows® CE) or the display unit for automobile manufacturers is explained later.

Calibration procedure

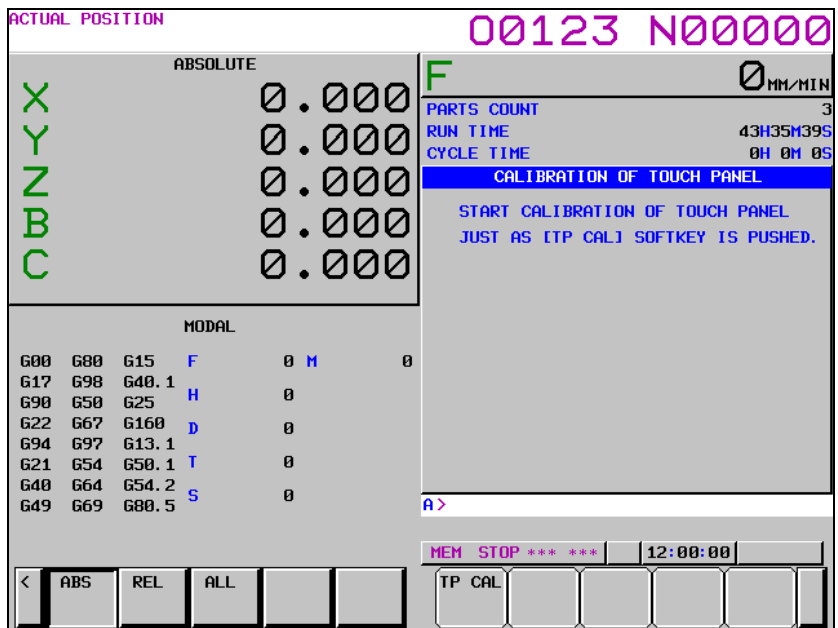

- <1> Enable the touch panel calibration screen.(Set bit 5 (DCL) of parameter No. 3113 to 1.)
- <2> Press function key .
- <3> Press the continuous menu key  several times. The [TOUCH PANEL] soft key is displayed.
- <4> Press the [TOUCH PANEL] soft key then the [(OPRT)] soft key. The [TP CAL] soft key is displayed.

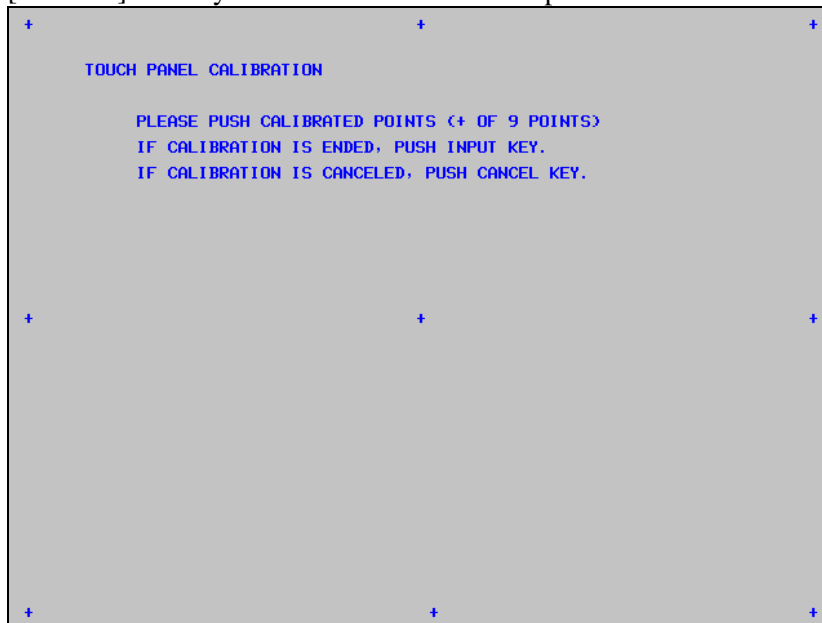

<5> Pressing the [TP CAL] soft key causes a full-screen touch panel calibration screen to appear.



<6> Click the 9 calibration points with a stylus pen. The marker of a normally clicked point changes from "+" to "o". If you fail to click right on a "+" mark, the message "Your stylus pen is not right on a "+" mark. Click again." appears.

<7> After clicking all 9 calibration points, clicking the  key completes calibration. To quit or retry calibration, click the  key. The previous screen appears again. Before clicking 9 calibration points, clicking the  key aborts calibration.

<8> When calibration ends normally, the message "Calibration ended" appears.

<9> After completing calibration, disable the touch panel calibration screen (by resetting the DCL parameter (bit 5 of parameter No. 3113) to 0) to prevent operation mistake.

**- Touch panel calibration method (for LCD-moutend type control unit (personalcomputer function with Windows® CE) and display unit for stand-alone type control unit (personalcomputer function with Windows® CE))**

Open the control panel and start the stylus.

Make calibration as directed in the window.

**- Touch panel calibration method (for display unit for automotive manufacture)**

1. Press the ALT-O key to display the following function menu.

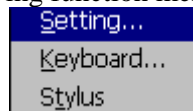

2. Select [Stylus] to display the calibration screen.

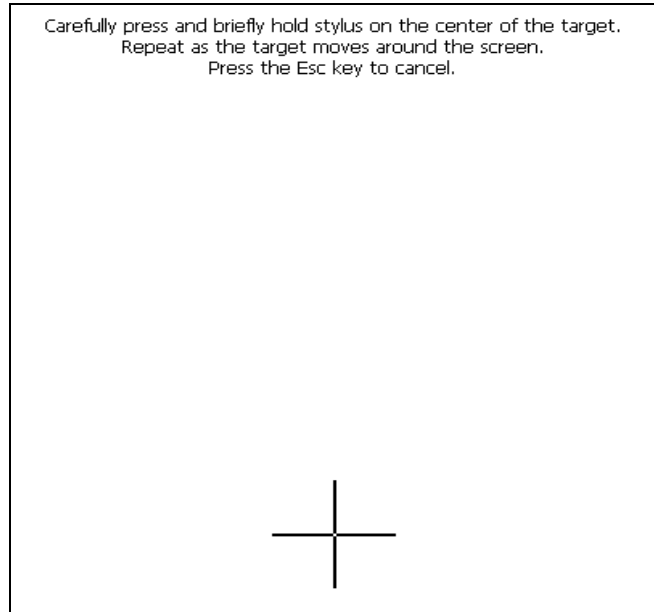

3. When the crosshair cursor appears, press and hold the center of the cursor until it disappears (about three seconds).
4. When the cursor position moves, perform step 3 again. Repeat this process a total of five times.
5. Press the RETURN key to close the calibration screen. To cancel the settings of the touch panel, press the ESC key.

## 3.15 REPLACING THE BACKUP UNIT

When "NCBOOT32- A battery backup hardware alarm(04E5)" appears on the screen of the personalcomputer function with Windows<sup>®</sup> CE, replace the backup unit.



### Procedure

- <1> Turn off the CNC power, replace the backup unit, and turn on the power again.
- <2> When the Windows screen appears, press the Ctrl key and Aux key of the MDI in sequence to display the start menu, and start Windows Explorer.
- <3> Execute "Storage Card\Fanuc\NCBOOT32.exe".
- <4> When a pop-up menu appears at the lower left of the screen, select "Open".
- <5> Check "Enable battery backup unit" to enable backup operation.
- <6> Select "OK" to close NCBOOT32.
- <7> Execute "Storage Card\Fanuc\NCBOOT32.exe".
- <8> When a pop-up menu appears at the lower left of the screen, select "Save".
- <9> Turn off the CNC power and back on again. Confirm that a backup operates normally and no alarm appears.

# 4 MAINTENANCE OF THE OTHER UNITS

## 4.1 CAUTIONS COMMON TO THE OTHER UNITS

### - Replacing fuses



#### WARNING

Before replacement of a blown fuse, the cause of the blown fuse must be corrected. So, fuse replacement work must be done only by a person who is trained in the related maintenance and safety requirements. When opening the cabinet and replacing a fuse inside, be careful not to touch the high-voltage circuits (marked with and fitted with an insulating cover). Touching the uncovered high-voltage circuits presents an extremely dangerous electric shock hazard.

See the descriptions of each unit in this chapter for the locations of their fuses.

See also Appendix B, “LISTS OF UNITS, PRINTED CIRCUIT BOARDS, AND CONSUMABLES” for the specifications of the fuses for each unit.

## 4.2 UNITS SUPPORTING I/O Link *i*

### 4.2.1 Items Common to Units Supporting I/O Link *i*

#### - Meanings of LED displays on units supporting I/O Link *i*

The standard I/O Link *i* incorporates three LEDs, “LINK” (green), “ALM” (red), and “FUSE” (red) for each unit separately. The information represented using each LED is as follows:

**LED 「LINK」 (green)** Indicates the status of communication by the unit of interest.

**LED 「ALM」 (red)** Indicates that an alarm has been issued in the unit of interest.

**LED 「FUSE」 (red)** Indicates where there is a blown fuse in the unit of interest.

See Section 10.26 for descriptions of the on/off states of the LEDs and their meanings.

#### - Status Alarm

Some I/O units have a function which detects unit errors including DO alarms (ground faults) and DO common voltage errors. If these units detect an error described above, how detected information is transferred to the master differs between the I/O Link and I/O Link *i*.

With the I/O Link, detected information is transferred to the master as DI signals. For this reason, to allow the master to reference the detected information, as many signals as required for the detected information must be assigned to X addresses. As many signals as required for the detected information are assumed as the number of DI signals used by the group and channel.

With the I/O Link *i*, detected information is called a status alarm, and the CNC is notified of the status alarm separate from DI signals. For this reason, it is not necessary to assign the information to X addresses. If an error occurs, the information is output to the system relay (R or Z) area. The information only for one group per channel is output to the system relay area. Only the information for the first group in which a status alarm is detected is output.

Given below are the examples of system relay areas where a status alarm is issued.

See the descriptions of each unit in this section for the correspondence between the slot number and alarm information number for them.

For details of the system relay area, refer to the FANUC Series 30i/31i/32i-MODEL B PMC Programming Manual (B-64513EN).

[Reference] System relay area related to a status alarm

Channel 1	Channel 2	7	6	5	4	3	2	1	0
R9268(Z268)	R9276(Z276)	Status	Type						
R9269(Z269)	R9277(Z277)				Group number				
R9270(Z270)	R9278(Z278)				Slot number				
R9271(Z271)	R9279(Z279)	Alarm information number							
R9272(Z272)	R9280(Z280)	Y address number							
R9273(Z273)	R9281(Z281)								
R9274(Z274)	R9282(Z282)					PMC path			
R9275(Z275)	R9283(Z283)	Alarm data							

[Reference] Simple description of signals

Name	Description
Status	Indicates that a status alarm occurs when this signal is set to 1.
Type	Indicates the type of status alarm. 0: DO alarm (such as a ground fault), 1: Other than a DO alarm (such as a DO common voltage error)
Group number	Outputs a group number (0 to 23).
Slot number	Outputs a numeric value 0 to 31, which indicates slot number 1 to 32.
Alarm information number	Outputs the position of the alarm information corresponding to the alarm which occurs (byte position in the slot).
Y address number	Outputs the Y address number of the relevant DO signal. Valid when the PMC path value is other than 0.
PMC path	Outputs the PMC path at the Y address assigned to the relevant DO signal. Outputs 0 if no address is assigned to the DO signal.
Alarm data	Outputs information on the alarm which occurs. Outputs 1 to the bit corresponding to the alarm which occurs.

## 4.2.2 I/O Module for Connector Panel [Supporting I/O Link *i*]

### - Specification

Name	Ordering specifications	Specification
I/O module for connector panel (basic module)	A03B-0824-C001	DI/DO : 24/16
I/O module for connector panel (extension module A)	A03B-0824-C002	DI/DO : 24/16 With MPG interface
I/O module for connector panel (extension module B)	A03B-0824-C003	DI/DO : 24/16 Without MPG interface
I/O module for connector panel (extension module C)	A03B-0824-C004	DO : 16 2A output module
I/O module for connector panel (extension module D)	A03B-0824-C005	Analog input module
Fuse (spare parts)	A03B-0815-K002	1A (For basic module)
Flat cable between modules	A03B-0815-K100	20 mm long Suitable for a module interval of 32 mm



- Connector and fuse locations

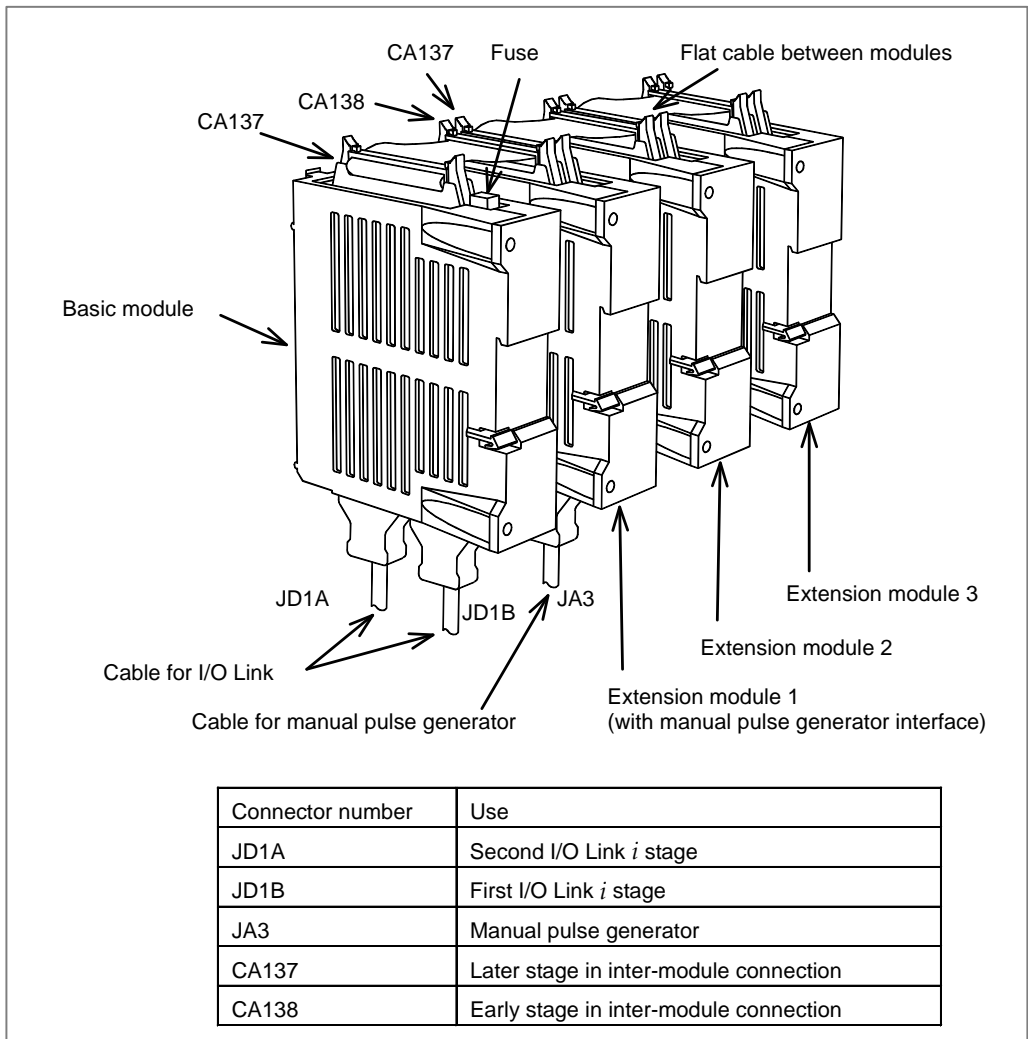

**- LED**

The basic module incorporates a green LED, “LINK”, and two red LEDs, “ALM” and “FUSE”. See Subsection 4.2.1 for descriptions of the correspondence between the on/off state of each LED and the status of the I/O module for connector panel.

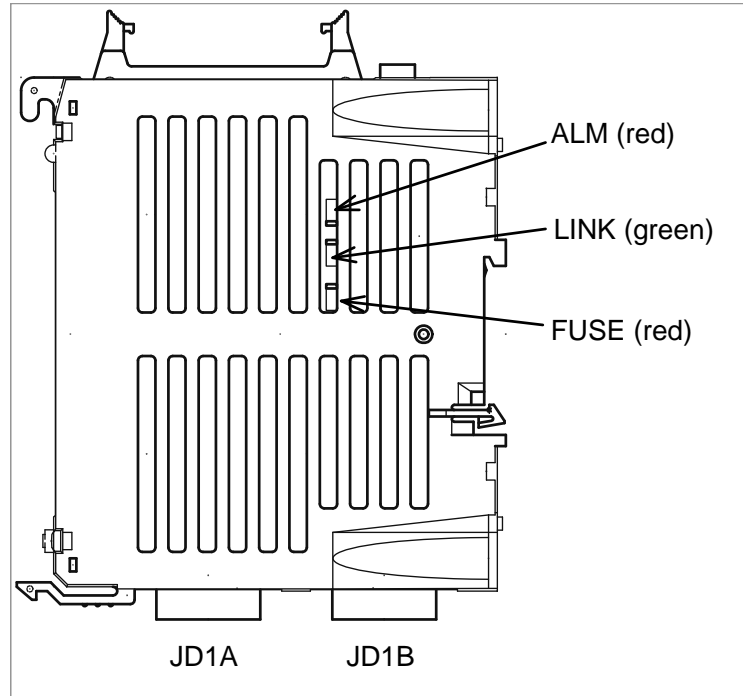

**- Rotary switch**

**⚠ CAUTION**  
 The rotary switch on each extension module is used to connect them by skipping other extension modules (slots).  
 When replacing extension modules, set the rotary switch on a replacing module in the same manner as for the replaced module.

**Method of setting (control and setting method)**

A control (rotary switch) is provided on the location shown below of each expansion module. When changing the setting, turn the rotary switch with a flat-blade screwdriver with a tip diameter of about 2.5 mm.

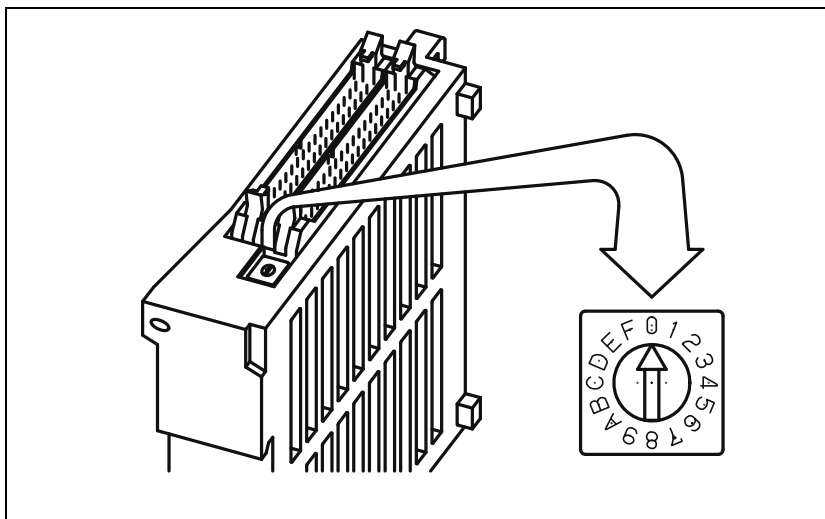

**- Correspondence between slot numbers and intra-slot byte addresses**

The table below lists the slot number and intra-slot byte address for this module.

Slot number	Intra-slot byte address	DO address	Location
1	0	$Y_{n_1}$	Basic module
1	1	$Y_{n_1+1}$	Basic module
2	0	$Y_{n_2}$	Extension module 1
2	1	$Y_{n_2+1}$	Extension module 1
3	0	$Y_{n_3}$	Extension module 2
3	1	$Y_{n_3+1}$	Extension module 2
4	0	$Y_{n_4}$	Extension module 3
4	1	$Y_{n_4+1}$	Extension module 3

**4.2.3 I/O Module for Operator’s Panel (Supporting Matrix Input) [Supporting I/O Link *i*]**

**- Specification**

Name	Specification	Remark
I/O module for operator’s panel	A03B-0824-K200	
Fuse (spare parts)	A03B-0815-K001	1A

**- Connector, LED, and fuse locations**

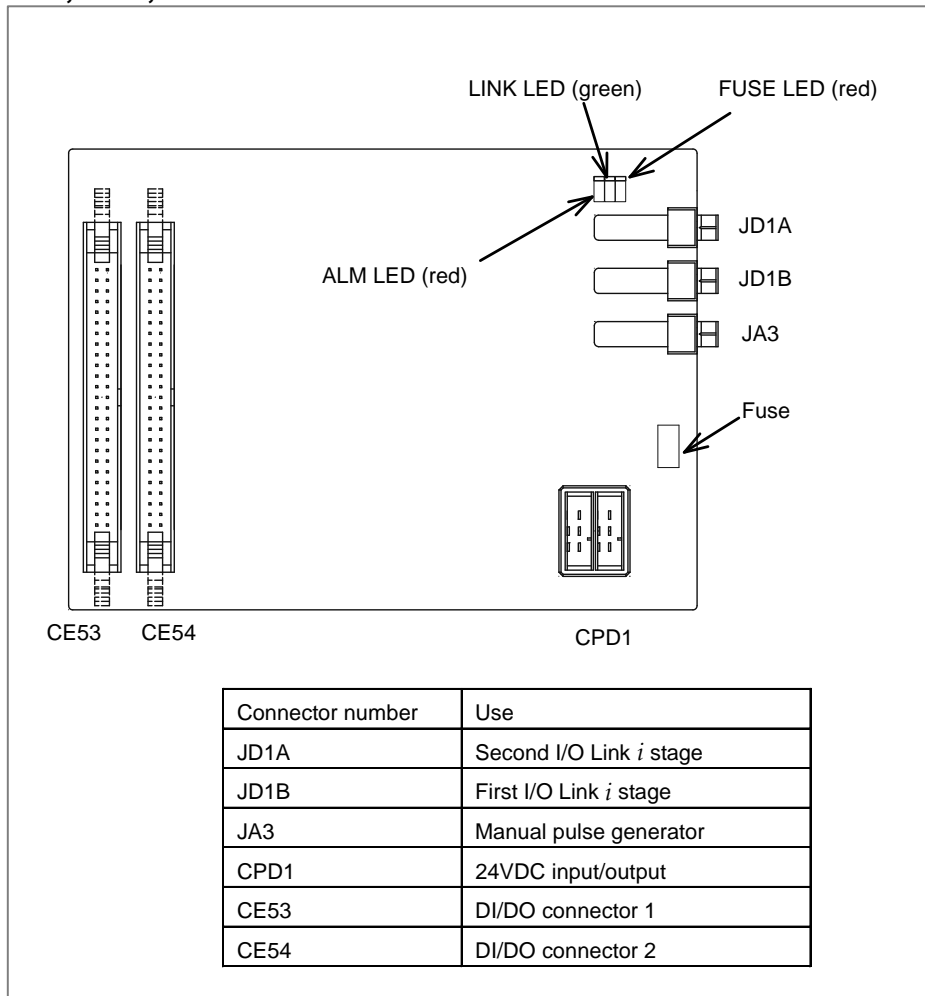

### - LED

The I/O module for operator's panel incorporates a green LED, "LINK", and two red LEDs, "ALM" and "FUSE" in above figure.

See Subsection 4.2.1 for descriptions of the correspondence between the on/off state of each LED and the status of the I/O module for operator's panel.

### - Correspondence between slot numbers and intra-slot byte addresses

The table below lists the slot number and intra-slot byte address for this module.

With this module, DO alarms (such as ground fault) are detected for each byte separately.

Information output to the system relay area			Description
Slot number	Alarm information number	Alarm data bit 0 data	
1	0	1	Y <sub>n1</sub> error
1	1	1	Y <sub>n1+1</sub> error
1	2	1	Y <sub>n1+2</sub> error
1	3	1	Y <sub>n1+3</sub> error
1	4	1	Y <sub>n1+4</sub> error
1	5	1	Y <sub>n1+5</sub> error
1	6	1	Y <sub>n1+6</sub> error

## 4.2.4 Connection of I/O Module for Operator's Panel and I/O Module for Power Magnetics Cabinet [Supporting I/O Link *i*]

### - Specification

Item	Ordering specifications	Remarks
I/O module for operator's panel (with MPG interface)	A03B-0824-K202	DI : 48 points DO : 32 points With MPG interface
I/O module for power magnetics cabinet (without MPG interface)	A03B-0824-K203	DI : 48 points DO : 32 points Without MPG interface
Fuse (spare parts)	A03B-0815-K001	1A

- Connector, LED, and fuse locations

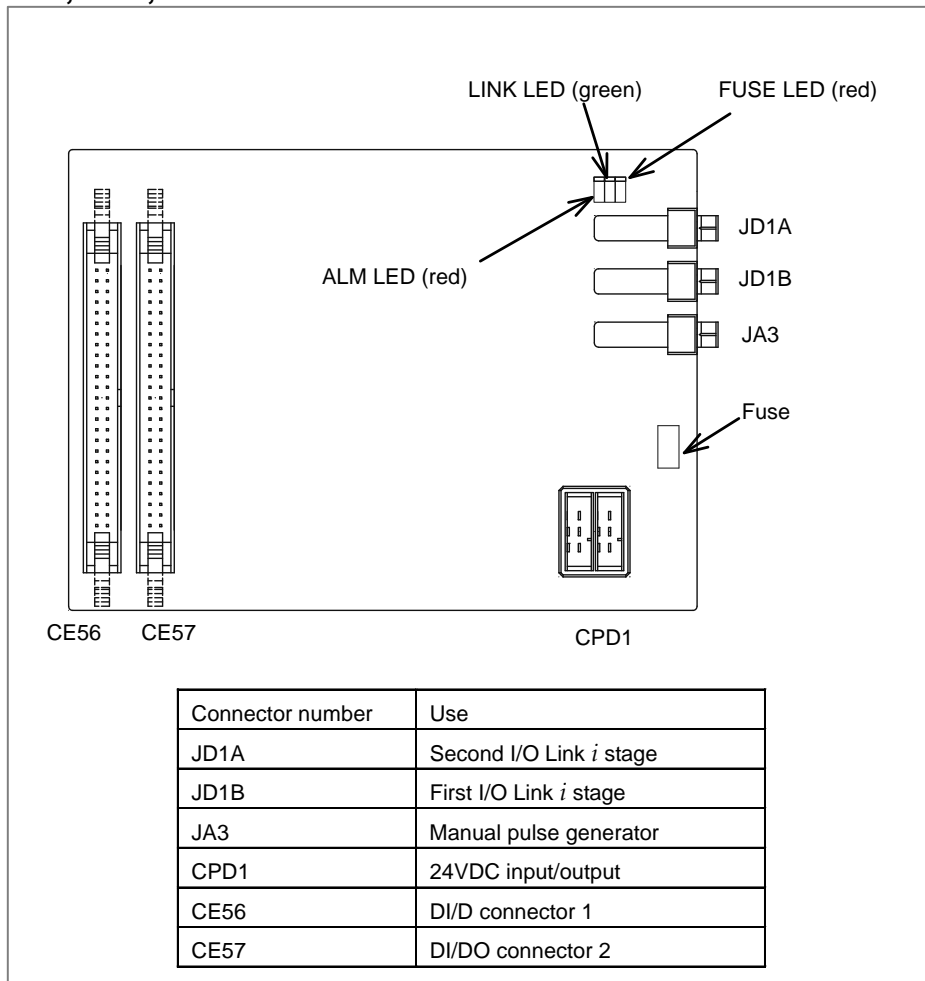

- LED

The I/O module for operator’s panel incorporates a green LED, “LINK”, and two red LEDs, “ALM” and “FUSE” in above figure.

See Subsection 4.2.1 for descriptions of the correspondence between the on/off state of each LED and the status of the I/O module for operator’s panel.

- Correspondence between slot numbers and intra-slot byte addresses

The table below lists the slot number and intra-slot byte address for this module.

Slot number	Alarm information number	Address of the DO driver which detects an error
1	0	$Y_{n_1}$
1	1	$Y_{n_1+1}$
1	2	$Y_{n_1+2}$
1	3	$Y_{n_1+3}$

4.2.5 I/O Module Type-2 for Connector Panel [Supporting I/O Link *i*]

- Specification

Item	Ordering specifications	Specification
I/O module type-2 for connector panel (basic module B1)	A03B-0824-C040	DI/DO=48/32 With MPG interface
I/O module type-2 for connector panel (basic module B2)	A03B-0824-C041	DI/DO=48/32 Without MPG interface

Item	Ordering specifications	Specification
I/O module type-2 for connector panel (extension module E1)	A03B-0824-C042	DI/DO=48/32
Fuse (spare parts)	A03B-0815-K002	1 A (for basic module)
Inter-module flat cable	A03B-0815-K102	Cable length: 35 mm Module interval: 5 mm

- Connector, LED, and fuse locations

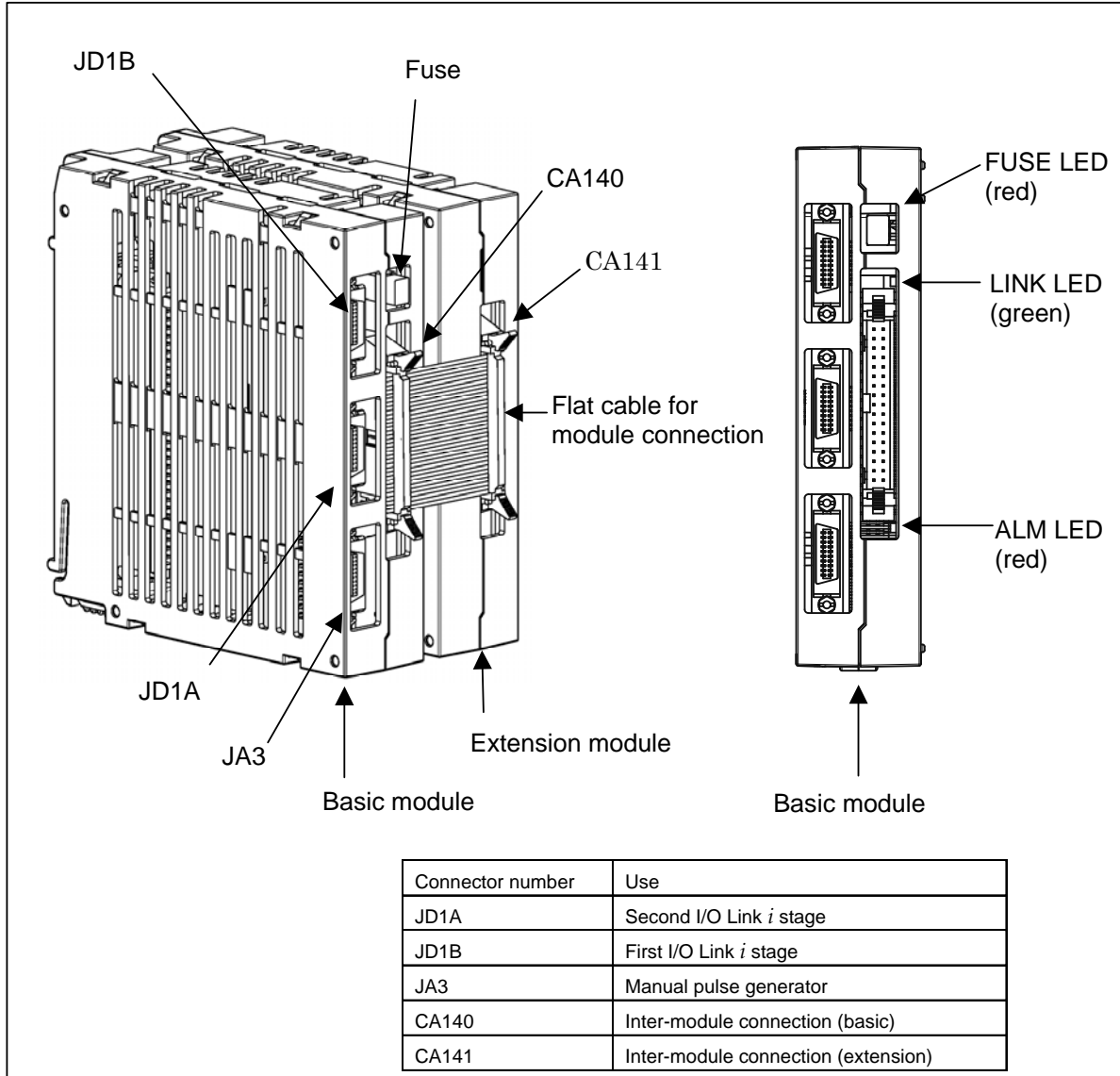

- LED

The basic module incorporates a green LED, “LINK”, and two red LEDs, “ALM” and “FUSE”. See Subsection 4.2.1 for descriptions of the correspondence between the on/off state of each LED and the status of the I/O module type-2 for connector panel.

- Correspondence between slot numbers and intra-slot byte addresses

The table below lists the slot number and intra-slot byte address for this module.

Slot number	Alarm information number	Address of the DO driver which detects an error	Location
1	0	Yn <sub>1</sub>	Basic module

Slot number	Alarm information number	Address of the DO driver which detects an error	Location
1	1	$Y_{n_1+1}$	Basic module
1	2	$Y_{n_1+2}$	Basic module
1	3	$Y_{n_1+3}$	Basic module
2	0	$Y_{n_2}$	Extension module
2	1	$Y_{n_2+1}$	Extension module
2	2	$Y_{n_2+2}$	Extension module
2	3	$Y_{n_2+3}$	Extension module

## 4.2.6 Terminal Type I/O Module [Supporting I/O Link $i$ ]

### - Specification

Item	Ordering specifications	Specification
Basic module	A03B-0823-C011	DI/DO: 24/16
Extension module A	A03B-0823-C012	DI/DO : 24/16 With MPG interface
Extension module B	A03B-0823-C013	DI/DO : 24/16 Without MPG interface
Extension module C	A03B-0823-C014	DO : 16 2-A output module
Extension module D	A03B-0823-C015	Analog input module
Extension module E	A03B-0823-C016	Analog output module
Fuse (spare parts)	A03B-0823-K001	2A (for basic module)
Spare terminal block set (for basic module and extension module A/B)	A03B-0823-K020	Cable-side terminal block set (including each of T1 through T4)
Spare terminal block set (for extension module C)	A03B-0823-K011	Cable-side terminal block set (including each of T1 and T2)
Spare terminal block set (for extension module D)	A03B-0823-K012	Cable-side terminal block set (including each of T1 and T2)
Spare terminal block set (for extension module E)	A03B-0823-K013	Cable-side terminal block set (including each of T1 and T2)
Inter-module cable A	A03B-0823-K100	Cable length: 100 mm, 52 pins Used for extension module connection



### CAUTION

The spare terminal board set is a replacement set for a cable-side terminal board supplied with the main unit.

- Locations of connectors, fuses, LEDs, etc.

Basic module A03B-0823-C011

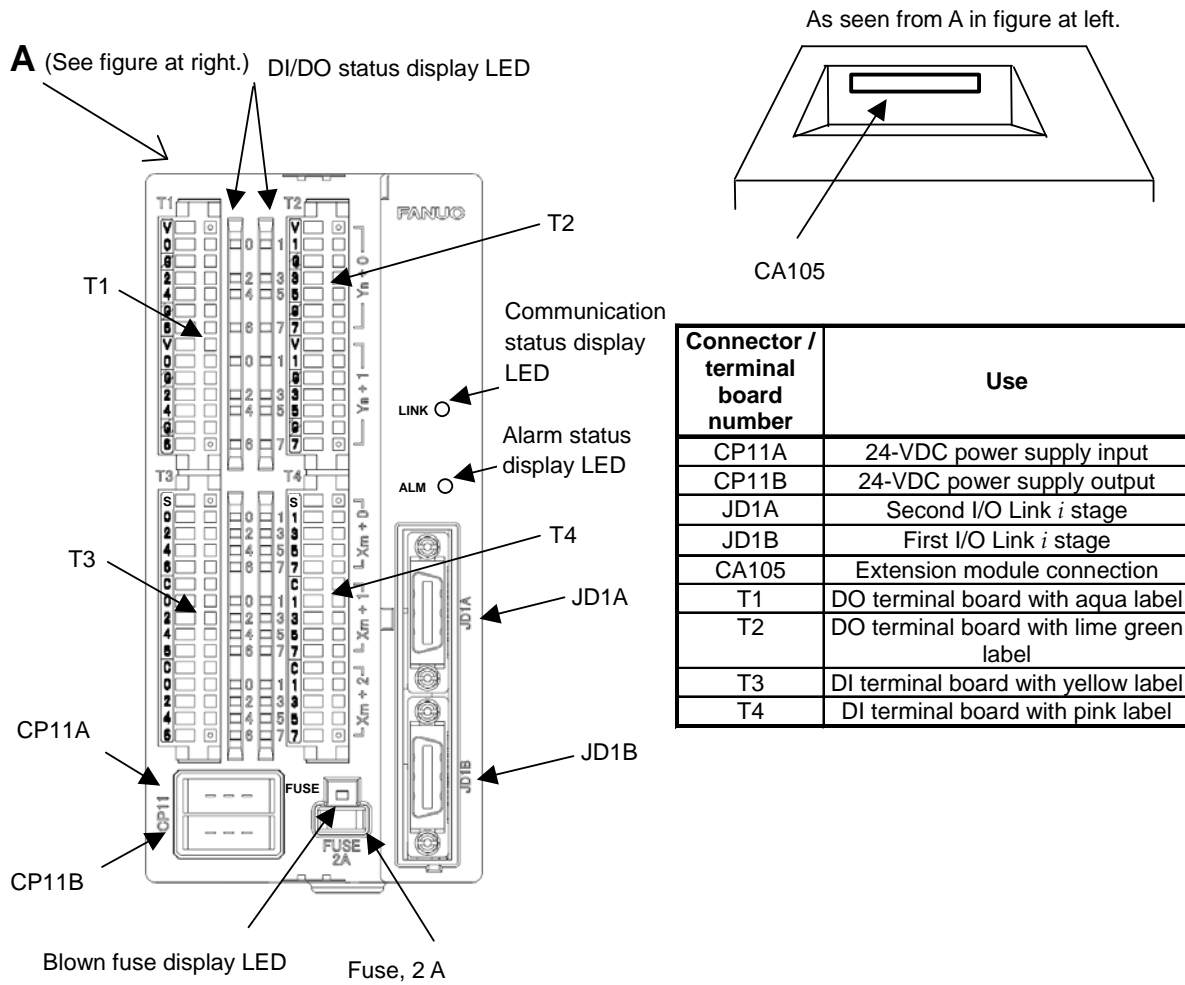

Connector / terminal board number	Use
CP11A	24-VDC power supply input
CP11B	24-VDC power supply output
JD1A	Second I/O Link <i>i</i> stage
JD1B	First I/O Link <i>i</i> stage
CA105	Extension module connection
T1	DO terminal board with aqua label
T2	DO terminal board with lime green label
T3	DI terminal board with yellow label
T4	DI terminal board with pink label

Meanings of LED displays

LED	Meaning
LINK	Status of communication
ALM	Occurrence of alarm
FUSE	Blown fuse
DO 0 to 7 (2 bytes)	Light when DO is ON.
DI 0 to 7 (3 bytes)	Light when DIO is ON.



**Extension module A A03B-0823-C012**

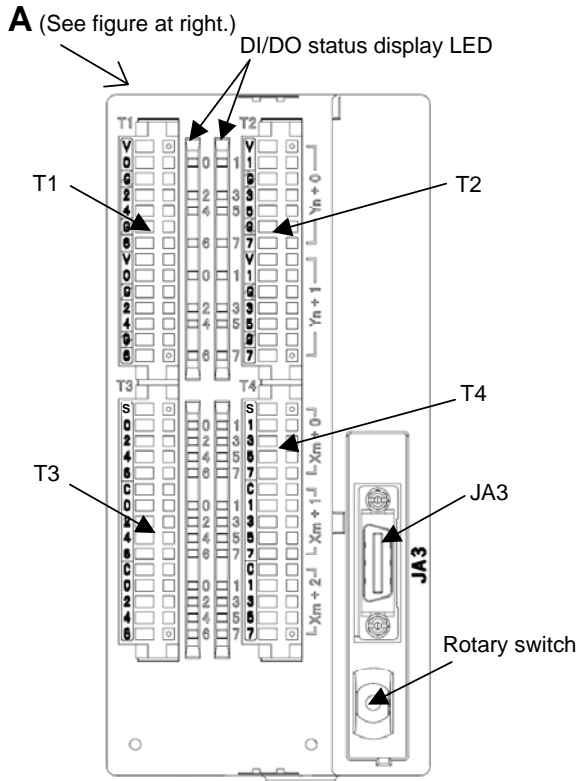

As seen from A in figure at left.

(Common to A03B-0823-C012 and A03B-0823-C013)

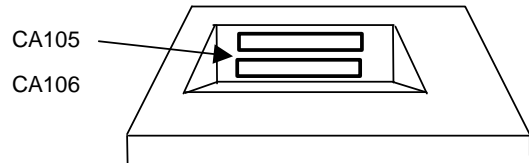

Connector / terminal board number	Use
JA3	MPG interface
CA105	Extension module connection (to next-stage extension module)
CA106	Extension module connection (to previous-stage basic module)
T1	DO terminal board with aqua label
T2	DO terminal board with lime green label
T3	DI terminal board with yellow label
T4	DI terminal board with pink label

**Extension module B A03B-0823-C013**

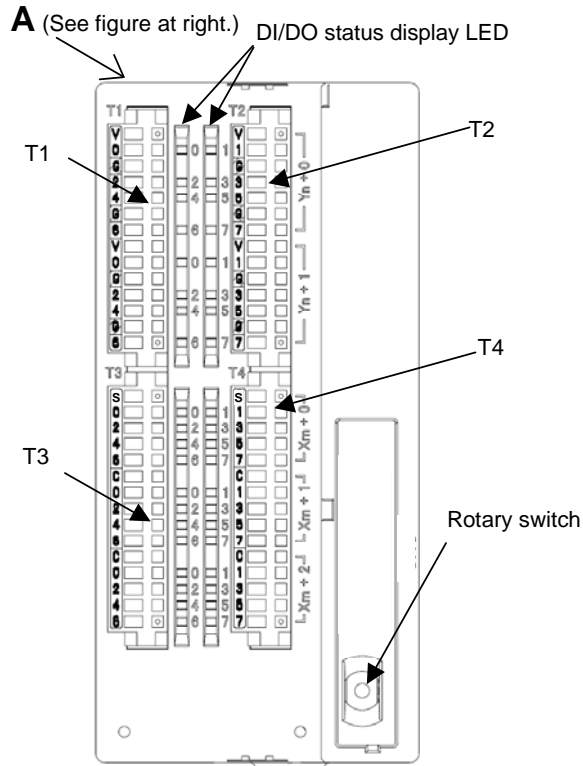

Connector / terminal board number	Use
CA105	Extension module connection (to next-stage extension module)
CA106	Extension module connection (to previous-stage basic module)
T1	DO terminal board with aqua label
T2	DO terminal board with lime green label
T3	DI terminal board with yellow label
T4	DI terminal board with pink label

Meanings of LED displays

(Common to A03B-0823-C012 and A03B-0823-C013)

LED	Meaning
DO 0 to 7 (2 bytes)	Light when DO is ON.
DI 0 to 7 (3 bytes)	Light when DIO is ON.

**Extension module C A03B-0823-C014**

As seen from A in figure at left. (Common to A03B-0823-C014 and A03B-0823-C015)

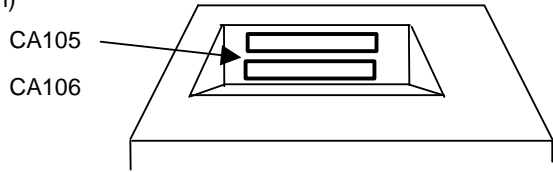
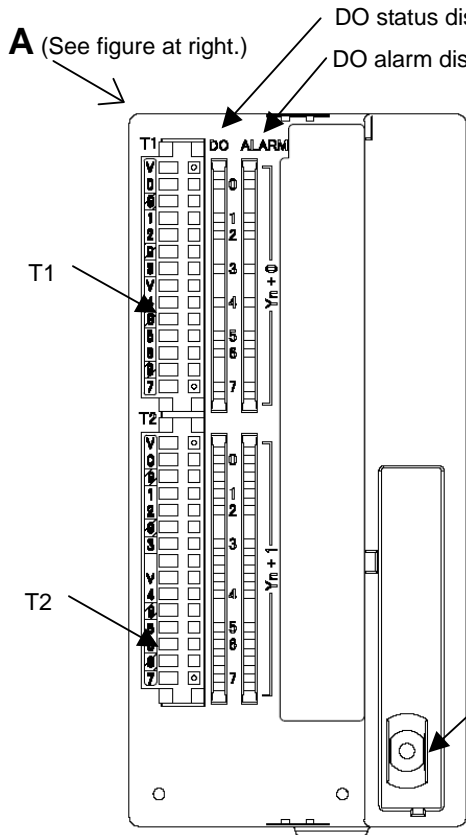

Connector / terminal board number	Use
CA105	Extension module connection (to next-stage expansion module)
CA106	Extension module connection (to previous-stage basic or extension module)
T1	DO terminal board with aqua label
T2	DO terminal board with lime green label

Rotary switch  
Meanings of LED displays

LED	Meaning
DO 0 to 7 (2 bytes)	Light when DO is ON.
ALARM 0 to 7 (2 bytes)	Light to indicate an alarm.

**Extension module D A03B-0823-C015**

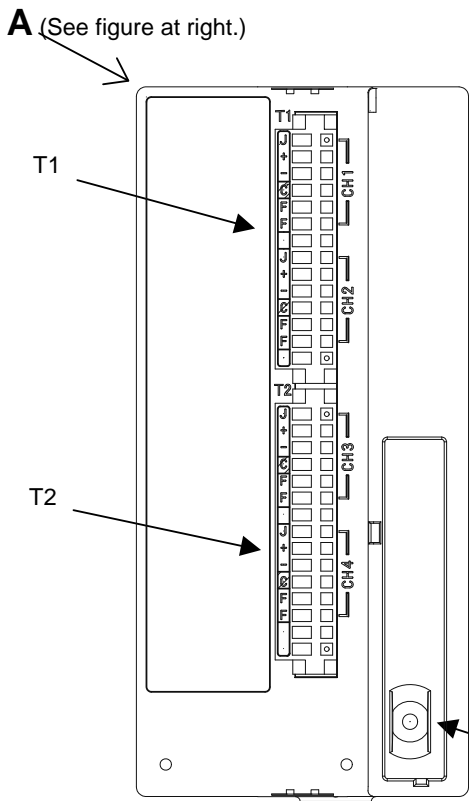

Connector / terminal board number	Use
CA105	Extension module connection (to next-stage expansion module)
CA106	Extension module connection (to previous-stage basic or extension module)
T1	Analog input CH1 and CH2 terminal board with yellow label
T2	Analog input CH3 and CH4 terminal board with pink label

**Extension module E A03B-0823-C016**

**A** (See figure at right.)

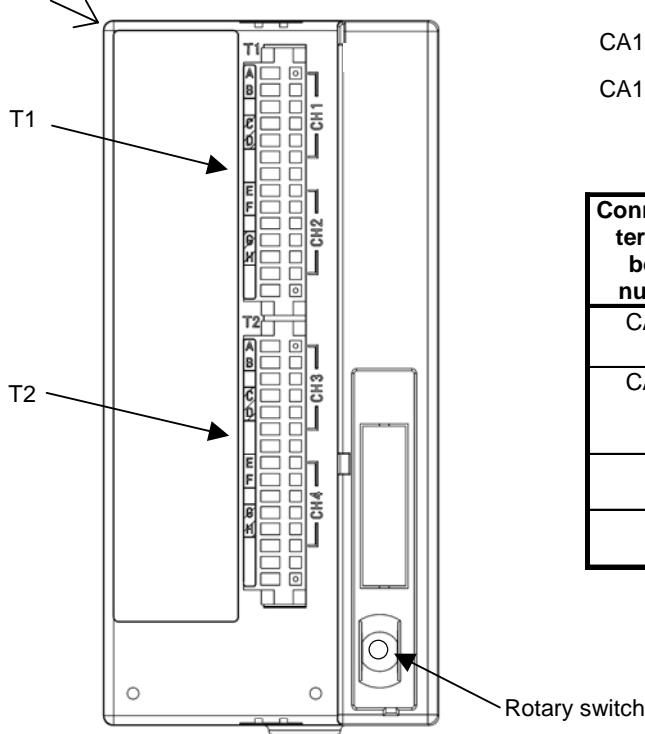

As seen from A in figure at left.

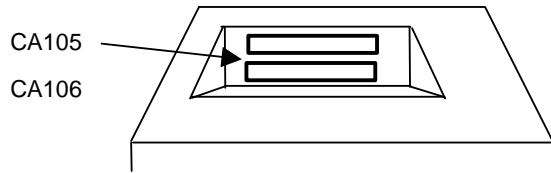

Connector / terminal board number	Use
CA105	Extension module connection (to next-stage expansion module)
CA106	Extension module connection (to previous-stage basic or extension module)
T1	Analog input CH1 and CH2 terminal board with lime green label
T2	Analog input CH3 and CH4 terminal board with sky blue label

**States when the protection function is activated in extension module C**

The following table lists the DO output and alarm data states when a DO error occurs in extension module C and the protection function is activated.

State	PMC output	Module DO output	DO state indication LED (green)	DO alarm LED (red)	Alarm data
Normal operation	0	OFF	Turned off	Turned off	0
	1	ON	Turned on	Turned off	0
Overheat protection function operation	0	OFF	Turned off	Turned off	0
	1	OFF	Turned off	Turned on	1
Over voltage protection function operation	0	OFF	Turned off	Turned on	1
	1	OFF	Turned off	Turned off	0
Disconnection detection	0	OFF	Turned off	Turned off	0
	1	ON	Turned on	Turned on	1

**⚠ CAUTION**

1 If the overheat protection function or over voltage protection function among the protection functions above is activated, the DO bit is kept OFF until the cause is eliminated. When the cause is eliminated, the DO bit is set to ON without restarting the system.

**⚠ CAUTION**

- 2 Disconnection detection is performed by monitoring, with an output element in the module, the current flowing through a load when DO output is ON. When the detected current value is about 100 mA or less, disconnection detection is assumed. So, when a device (such as an LED) with a small load current is connected, the DO alarm state results, assuming disconnection detection. Unlike the other protection functions, however, this function does not turn off DO output. If a connection is reactivated after the state of disconnection is once set, disconnection detection is canceled without restarting the system.

**- Rotary switch****⚠ CAUTION**

When replacing extension modules, set the rotary switch on a replacing module in the same manner as for the replaced module.

Re-setting the rotary switch on each extension module can be used to connect them by skipping other modules. For details, see descriptions of the rotary switch in Subsection 4.2.2, "I/O module for connector panel".

**- Correspondence between slot numbers and intra-slot byte addresses**

The table below lists the slot number and intra-slot byte address for this module.

Slot number	Intra-slot byte address	DO address	Location
1	0	$Yn_1$	Basic module
1	1	$Yn_1+1$	Basic module
2	0	$Yn_2$	Extension module 1
2	1	$Yn_2+1$	Extension module 1
3	0	$Yn_3$	Extension module 2
3	1	$Yn_3+1$	Extension module 2
4	0	$Yn_4$	Extension module 3
4	1	$Yn_4+1$	Extension module 3

**4.2.7 I/O Link Connection Unit [Supporting I/O Link *i*]****Specification**

Name	Specification
I/O Link connection unit	A02B-0333-C250
Fuse 1A (spare parts, 1 piece)	A03B-0815-K001

**Connector and fuse locations**

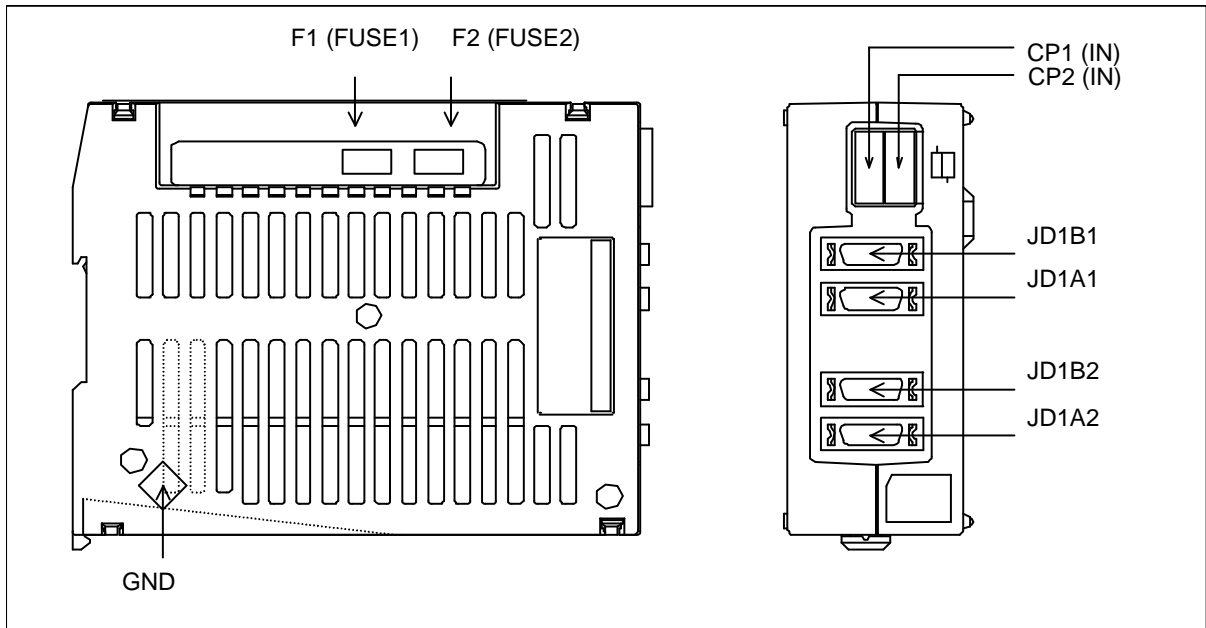

Connector number and fuse number	Application
CP1 (IN)	24 VDC power input (channel 1)
CP2 (IN)	24 VDC power input (channel 2)
JD1B1,JD1A1	I/O Link interface (channel 1)
JD1B2,JD1A2	I/O Link interface (channel 2)
GND	Signal ground terminal
F1 (FUSE1)	Fuse (channel 2, LED "FUSE1" lights if the relevant fuse blows)
F2 (FUSE2)	Fuse (channel 2, LED "FUSE2" lights if the relevant fuse blows)

**- LED display**

The I/O Link connection unit has two I/O Link channels, each incorporating a green LED, "LINKn", and two red LEDs, "ALMn" and "FUSEn", (where n is 1 or 2) as shown below.

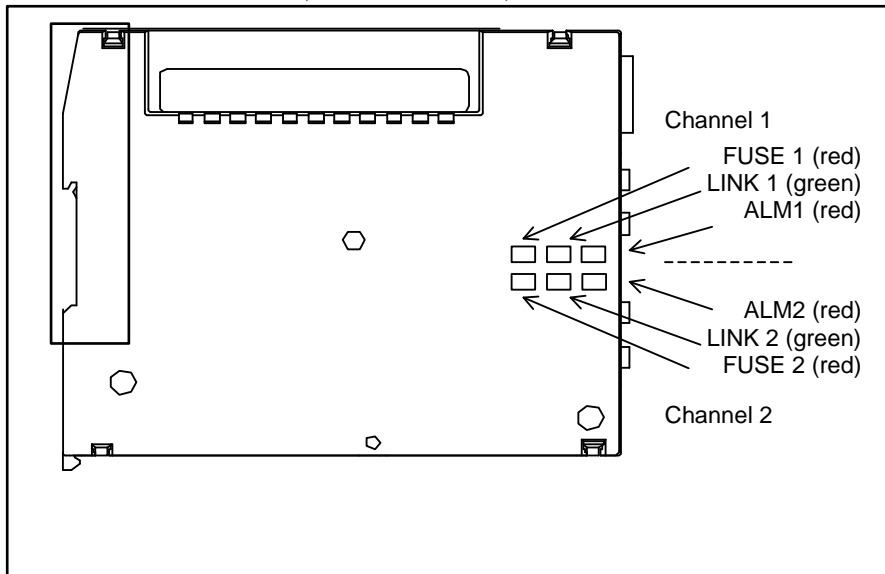

See Subsection 4.2.1 for the correspondence between the on/off state of each LED and the status of the I/O Link connection unit.

**CAUTION**

The I/O Link connection unit has two I/O Link channels, each having to be supplied with 24 V.

If the LED "LINK1" neither steadily lights nor blinks, check for 24 V on the connector CP1.

If the LED "LINK2" neither steadily lights nor blinks, check for 24 V on the connector CP2

## 4.2.8 Standard Machine Operator's Panel [Supporting I/O Link *i*]

### - Specification

Name	Specification
Standard machine operators panel Main panel	A02B-0323-C231
Standard machine operators panel Sub panel A	A02B-0236-C232
Standard machine operators panel Sub panel D	A02B-0236-C244
Set of transparent key tops (55 key tops)	A02B-0236-K170
Set of blank key tops (55 key tops)	A02B-0236-K171
Set of symbol English key tops (34 labeled key tops + 21 blank key tops)	A02B-0236-K174
Set of blank key tops (100 red blank key tops)	A02B-0236-K175
Set of blank key tops (100 green blank key tops)	A02B-0236-K176
Set of blank key tops (100 blue blank key tops)	A02B-0236-K177
Set of blank key tops (100 yellow blank key tops)	A02B-0236-K178
Screw caps (with 5 pieces included)	A02B-0319-K191
Fuse 1A (spare parts)	A03B-0815-K001

- Connector and fuse locations

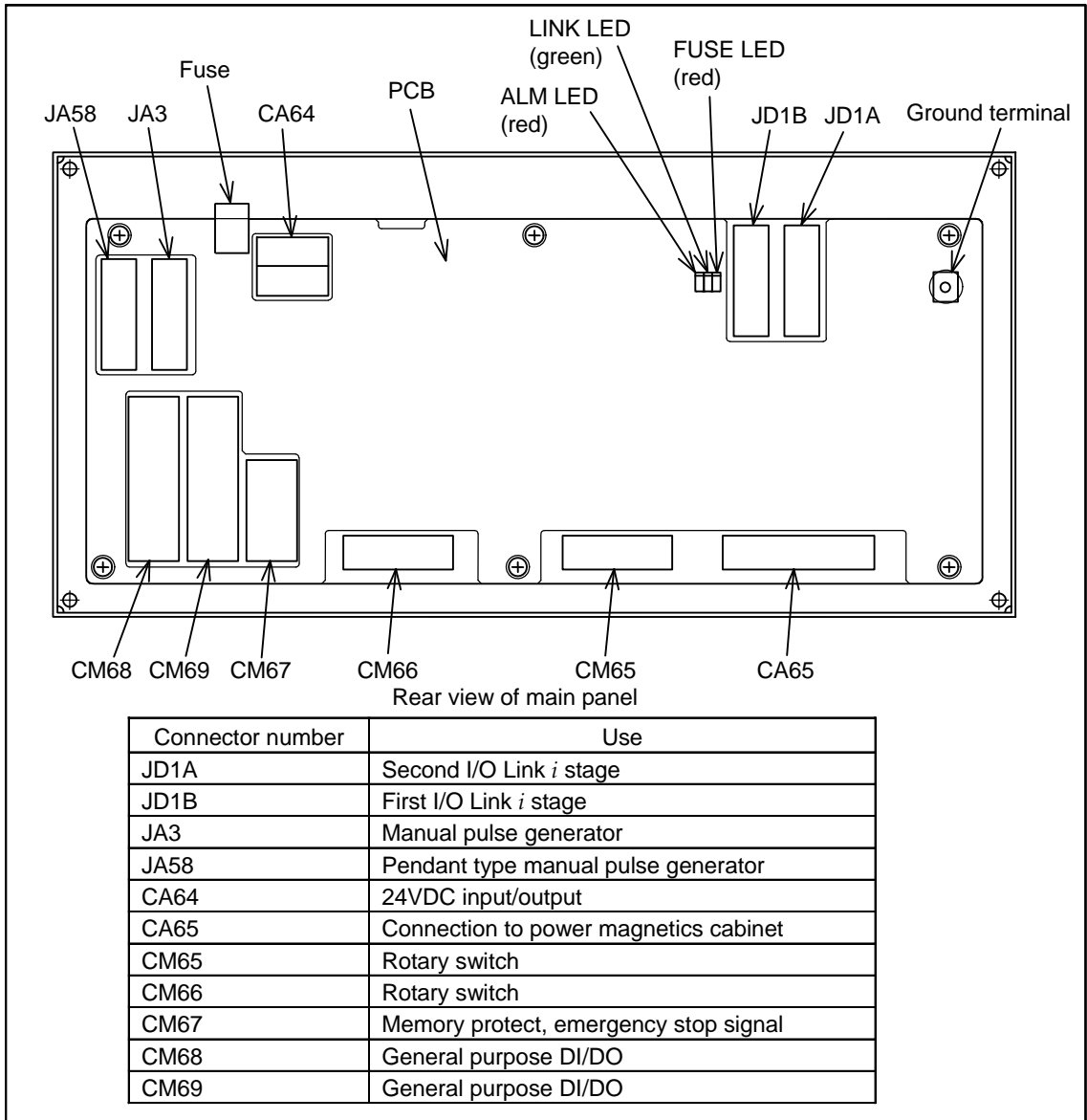

- LED

The printed circuit board on the rear of the main panel machine operator's panel incorporates a green LED, "LINK", and two red LEDs, "ALM" and "FUSE", as shown above.

See Subsection 4.2.1 for the correspondence between the on/off state of each LED and the status of the main panel.

- Correspondence between slot numbers and intra-slot byte addresses

The table below lists the slot number and intra-slot byte address for this operator's panel.

Information output to the system relay area		Address of the DO driver which detects an error
Slot number	Alarm information number	
1	0	Y <sub>n1</sub> error
1	1	Y <sub>n1+1</sub> error
1	2	Y <sub>n1+2</sub> error
1	3	Y <sub>n1+3</sub> error
1	4	Y <sub>n1+4</sub> error
1	5	Y <sub>n1+5</sub> error
1	6	Y <sub>n1+6</sub> error

Information output to the system relay area		Address of the DO driver which detects an error
Slot number	Alarm information number	
1	7	Y <sub>n+7</sub> error

### 4.3 UNITS SUPPORTING I/O Link

#### 4.3.1 I/O Link-AS-i Converter

- Specification

Name	Specification
For AS-i Ver2.0	A03B-0817-C001
For AS-i Ver2.1	A03B-0817-C002
Fuse 1A (spare parts)	A03B-0815-K001

- Locations of connectors

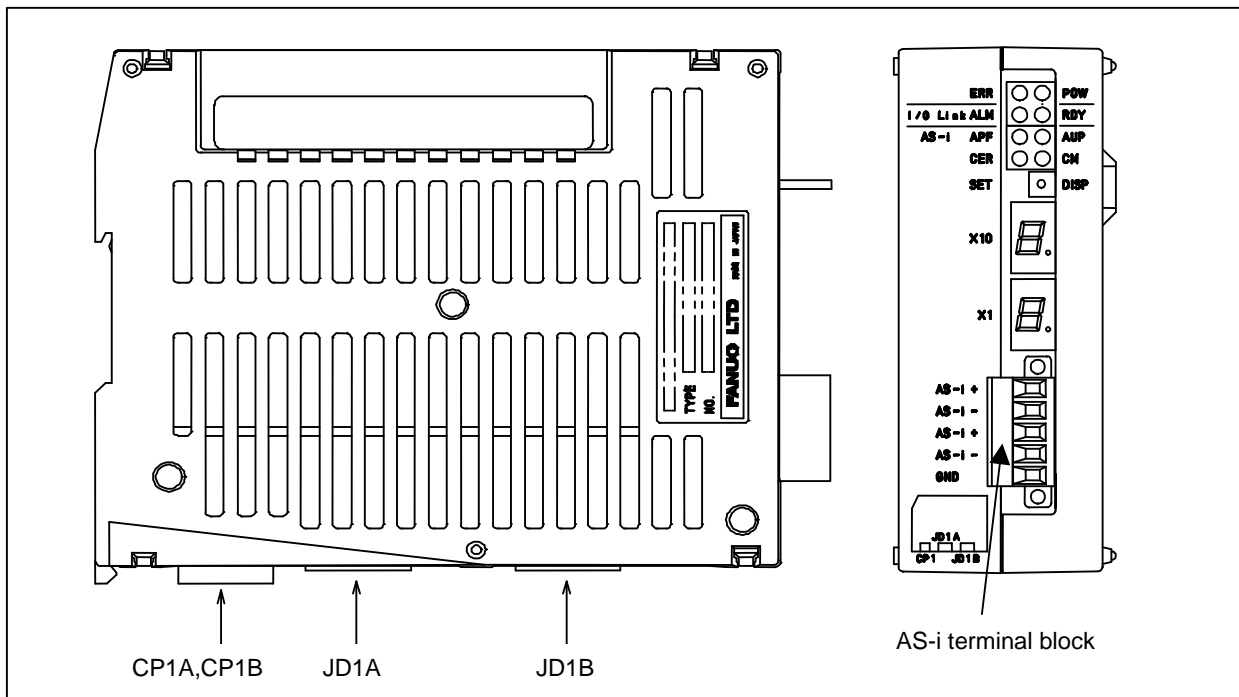

Connector number	Application
CP1A	24 VDC power input
CP1B	24 VDC power output
JD1A	Second I/O Link <i>i</i> stage
JD1B	First I/O Link <i>i</i> stage
AS-i terminal block	AS-i communication cable connection



**- Locations of fuses**

The fuse for the I/O Link-AS-i converter is on the printed circuit board in the case.

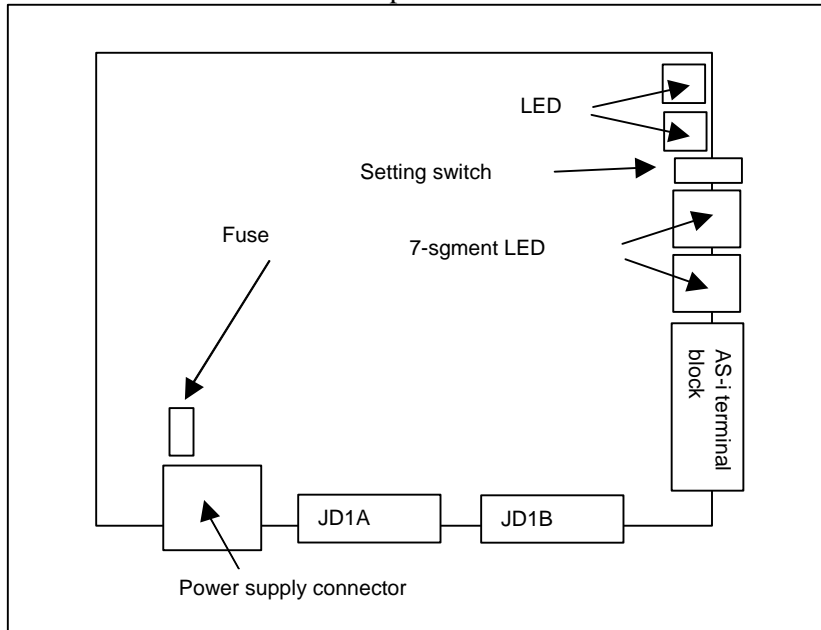

**- LED displays and setting switch**

The I/O Link-AS-i converter is equipped with status display LEDs and a setting switch. The equipped LEDs include four green, four red, and two 7-segment LEDs. Shown below are the location and use of each LED as well as what the setting switch is used for.

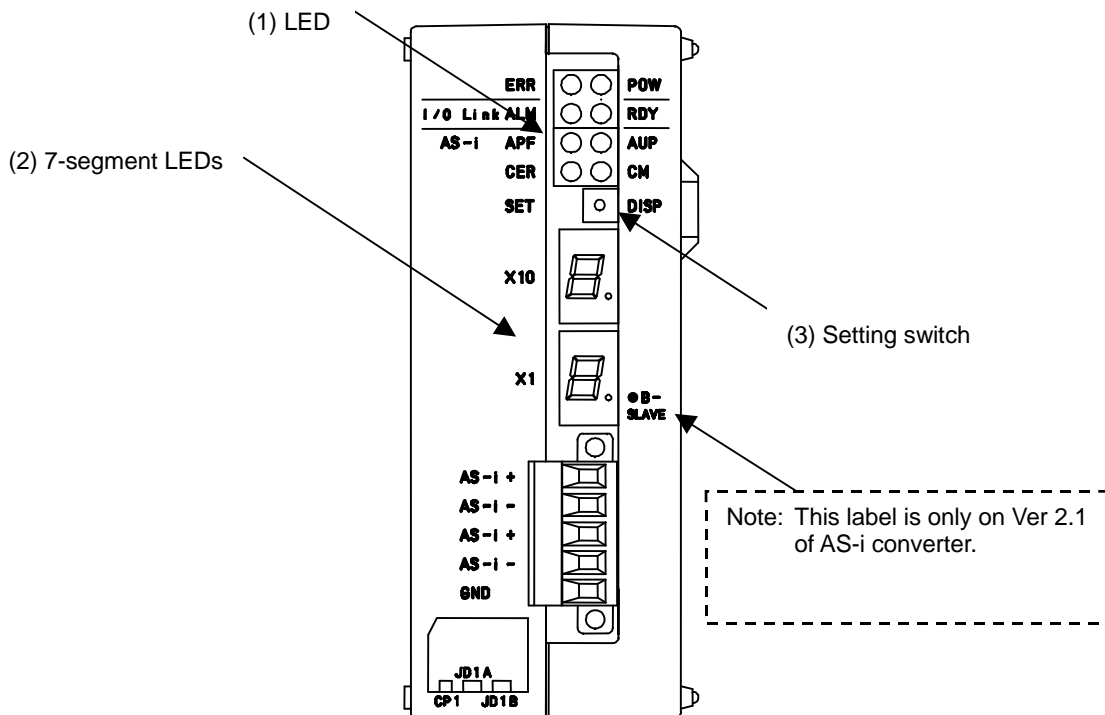

**(1) LED display**

Function	Label	Color	Description
	POW	Green	Lights to indicate that the power for the I/O Link - AS-i converter is on.
	ERR	Red	Lights to indicate a failure (whose details can be checked using the other LED displays (including the 7-segment LED displays) and status information on the I/O Link).
I/O Link	RDY	Green	Lights to indicate that the I/O Link is ready to communicate.
	ALM	Red	Lights to indicate that an alarm condition (whose details can be checked using the 7-segment LED displays) has occurred on the I/O Link.
AS-i	AUP	Green	Lights to indicate that the current operation mode is the protected mode and automatic address is available.
	CM	Green	Lights to indicate that the current operation is the configuration mode and goes off to indicate that the current operation is the protected mode.
	APF	Red	Lights to indicate an AS-i power fail.
	CER	Red	Lights to indicate that a registered slave configuration (LPS, ID code, or I/O configuration) does not match the currently connected slaves.

**(2) 7-segment LED displays**

LED display	Description
No display (If the setting switch is in the DISP position, the LED displays light according to the operation mode as listed below.)	Normal operation
E0	AS-i master error
E1	AS-i master EEPROM error
E2	ROM error
E3	RAM error
E5	Command execution error, SET switch execution error
E6	I/O Link slave watchdog alarm
E7	I/O Link RAM error
E8	Watchdog alarm 1
E9 or "." (dot) at the tens digit	Watchdog alarm 2
00 to 31	Slave address display
." (dot) at the ones digit	Lights when the B slave address is displayed.
88	Initialize operation, mode shifting, AS-i power fail

Operation mode	Normal operation	When setting switch is in DISP position
Configuration mode	No display	The LES of each connected slave unit is displayed at 1-second intervals.
Protected mode	The lowest slave address among those which encountered a configuration mismatch is displayed.	Each slave unit that has encountered a configuration mismatch is displayed at 1-second intervals (in an LPS-LES mismatch list). Note: Nothing is displayed if there is no mismatched slave unit.

**(a) Order in which Ver 2.1 displays slave numbers**

The slave number of the standard slave or the A slave is displayed first (with "." at the ones digit off). The slave number of the B slave is displayed next (with "." at the ones digit on).

Example: Address #10      Standard slave  
 Address #20A      A/B slave  
 Address #20B      A/B slave  
 Address #30      Standard slave

If the above slave units are connected, their slave numbers are displayed in the order shown below.

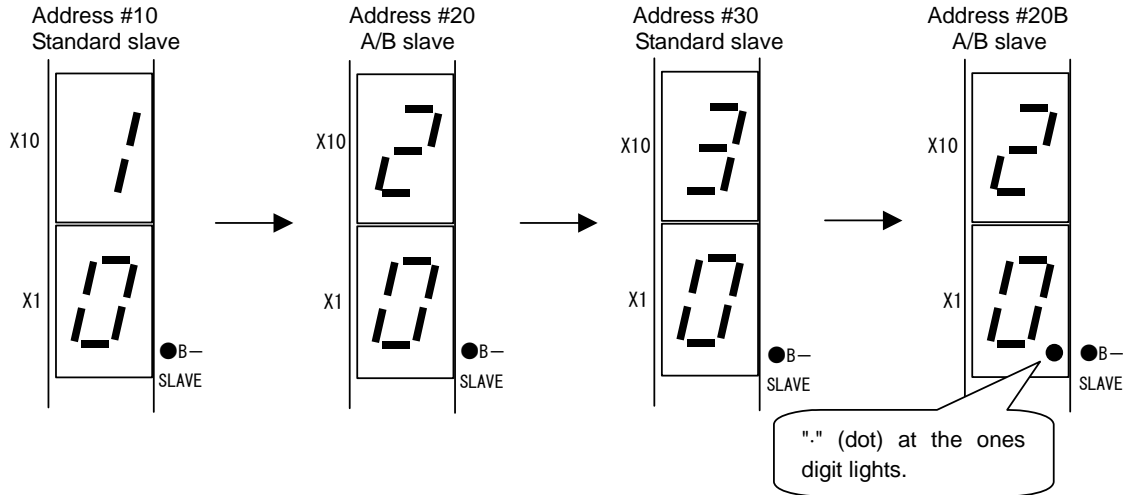

**(3) What the setting switch specifies**

Setting switch	Operation mode	
	Configuration	Protected mode
DISP	Slave addresses are displayed. No other input is acceptable until all slave addresses are displayed.	
	The LES of each of all connected slaves are displayed at about 1-second intervals.	Each slave unit which has encountered a configuration mismatch is displayed at about 1-second intervals (in an LPS-LES mismatch list). Note) Nothing is displayed if there is no mismatched slave unit.
SET	The operation modes are switched. Note) Keeping pressing the switch will not change the modes. Keep your hand off the switch for at least 1 second to make it off.	
	Keeping pressing the switch for at least 5 seconds causes the current slave configuration (LPS, ID code, I/O configuration, and parameters) to be registered, enables automatic addressing, and selects the protected mode. Note: Keeping pressing the switch for not longer than 5 seconds selects the protected mode but does not cause the configuration to be registered or enables automatic addressing.	Keeping pressing the switch for at least 5 seconds selects the configuration mode.  Note: Keeping pressing the switch for not longer than 5 seconds causes nothing.

**NOTE**  
 If a slave unit with address "0" is connected, no configuration registration is made and the protected mode is not selected. Alarm "E5" is displayed.

### - Dealing with errors

Check error status according to the LED display or status signals on the I/O Link.

Alarm or warning	LED display		Status signal on the I/O Link (X represents a PMC address)			Possible cause and action
	LED	7-segment LED	ERR X+18 bit1	AS-i data ready X+18 bit0	Other	
Normal operation	-	Off	0	1	-	-
Configuration mismatch	CER on	(Note)	0	1	X+16 bit7=0	The current slave configuration does not match the registered configuration. In the protected mode, selecting DISP causes the slave address encountering a configuration mismatch to be displayed. The possible causes include a slave unit failure, broken AS-i cable, and noise-induced AS-i communication error.
Initialization or mode change in progress	-	88	0	0	X+16 bit0=1 or X+17 bit0=1	
AS-i power fail	APF on	88	1	0	X+16 bit1=1	Check to see if the AS-i power supply is normal and cables from the AS-i power supply are normal. Normal operation is resumed when the AS-i power returns to normal.
AS-i master EEPROM fail	ERR on	E1	1	0	X+17 bit2=0	Turn the power off and on again. Because the configuration may be corrupted, register the configuration again (see NOTE on the next page). If the alarm occurs again, replace the converter unit.
AS-i master fail	ERR on	E0	1	0	X+18 bit2=1	Turn the power off and on again. If the alarm occurs again, replace the converter unit.
ROM fail	ERR on	E2	1	0	X+18 bit3=1	Replace the converter unit.
RAM fail	ERR on	E3	1	0	X+18 bit4=1	Replace the converter unit.
Watchdog 1	ERR on	E8	1	0	X+18 bit5=1	Replace the converter unit.
Watchdog 2	ERR on	E9 or ×10 ". "	1	0	-	An I/O Link system alarm occurred on the host CNC. Replace the converter unit.
I/O Link Slave Watchdog	ERR on	E6	-	-	-	An I/O Link system alarm occurred on the host CNC. The possible causes include a power failure in another unit on the I/O Link and a broken I/O Link cable as well as a noise-induced I/O Link communication error.
I/O Link RAM fail	ERR on	E7	-	-	-	An I/O Link system alarm occurred on host CNC. Replace the converter unit.

**NOTE**

- In the protected mode, the lowest address number among those encountering a configuration mismatch is displayed. In the configuration mode, nothing is displayed.
- Use ladder programs to detect and display converter unit errors.
- If a converter unit error occurs, both the DO and DI are turned off.
- If it is impossible to continue AS-i communication, a watchdog alarm condition occurs in the slave unit. How the DO behaves at the watchdog alarm is determined according to the slave unit type and parameter setting used. See the relevant slave unit specification.
- How to handle AS-i master EEPROM errors  
If the 7-segment LEDs display "E1", it is likely that the registered configuration may be corrupted. So, register it again according to the following chart.

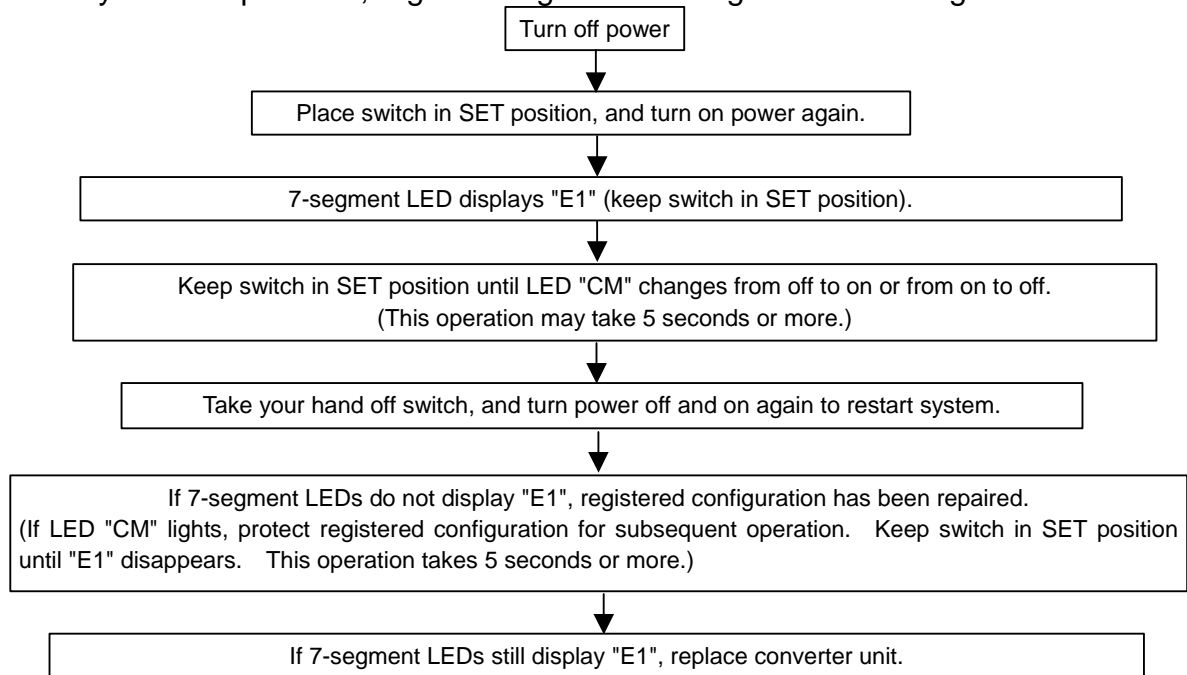

Note that if "E1" is displayed, the CNC may fail to start up.

The converter having this function is one shipped in or after June 2005. Those shipped before do not support this function. If EEPROM fails to operate normally, replace the converter unit.

#### - How to re-install

Once the I/O Link - AS-i converter is replaced, the new I/O Link - AS-i must be loaded with AS-i slave information according to the following procedure.

The procedure can be executed even when no I/O Link is connected (when power is supplied to the I/O Link - AS-i converter but not to the CNC or when no I/O Link cable is attached).

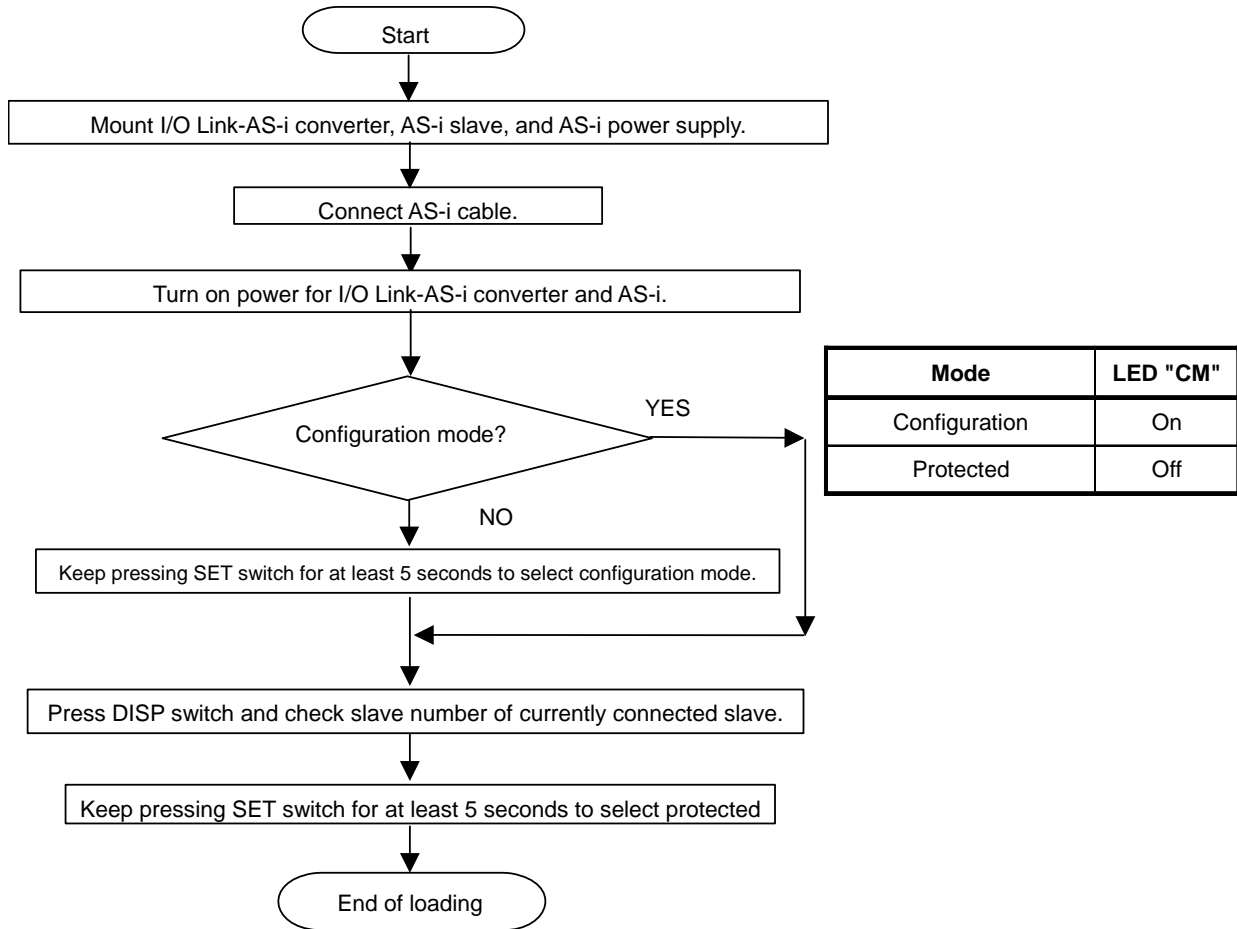

**NOTE**

- 1 When the protected mode is selected, the slave configuration is registered, and automatic addressing is enabled.
- 2 Turning the I/O Link-AS-i converter power on/off causes no operation mode change. To change the operation modes, use the SET switch.

**- Operating procedure for AS-i slave replacement**

Described below is the operating procedure for AS-i slave replacement (in case the slave is faulty). It is necessary to set a slave address, using either of the following two:

- (1) Commercially available address setting device.
- (2) Automatic address setting function of the I/O Link-AS-i converter; how to use the function is explained below.

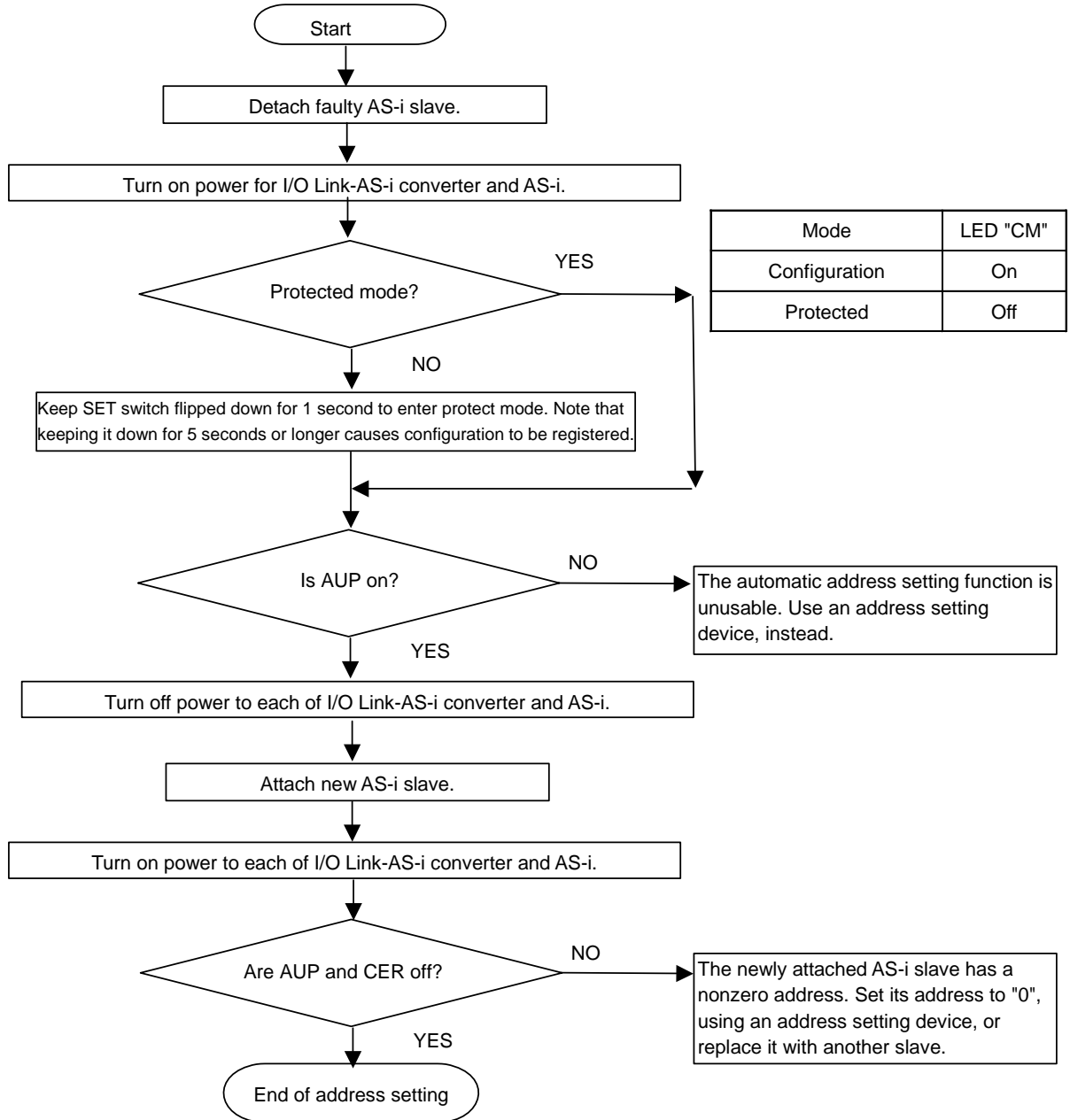

## 4.4 SEPARATE DETECTOR INTERFACE UNIT

### - Specification

Name	Specification
Basic unit	A02B-0323-C205
Additional unit	A02B-0323-C204

### - Connector mounting location

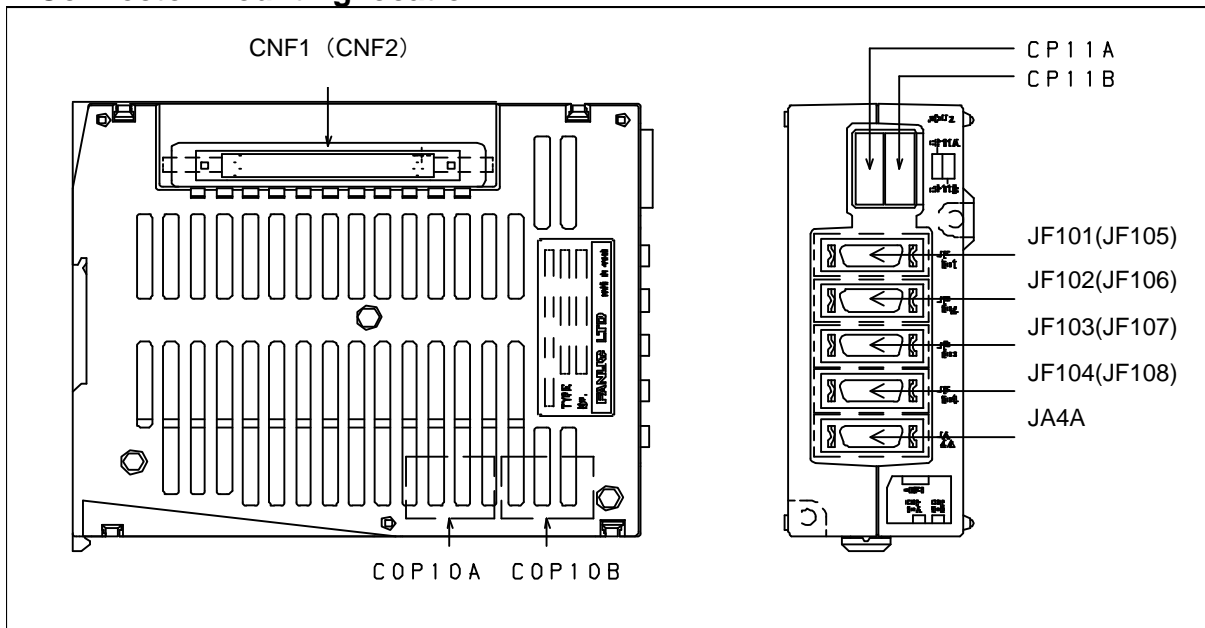

The parenthesized connector names are for the additional unit.

Connector number	Application
CP11A	24 VDC power input
CP11B	24 VDC power output
COP10A	Back stage of the FSSB interface
COP10B	Front stage of the FSSB interface
JF101 to JF104 (JF105 to JF108)	Separate detector interface
JA4A	Connection of a battery for the absolute detector
CNF1 (CNF2)	Connection of the additional unit

The parenthesized connector names are for the additional unit.

### - LED display

Status indication LEDs are installed on the board in the basic unit case. Two green LEDs (POWER and OPEN) and two red LEDs (ERR1 and ERR2) are provided. The locations and meanings of the LEDs are indicated below.



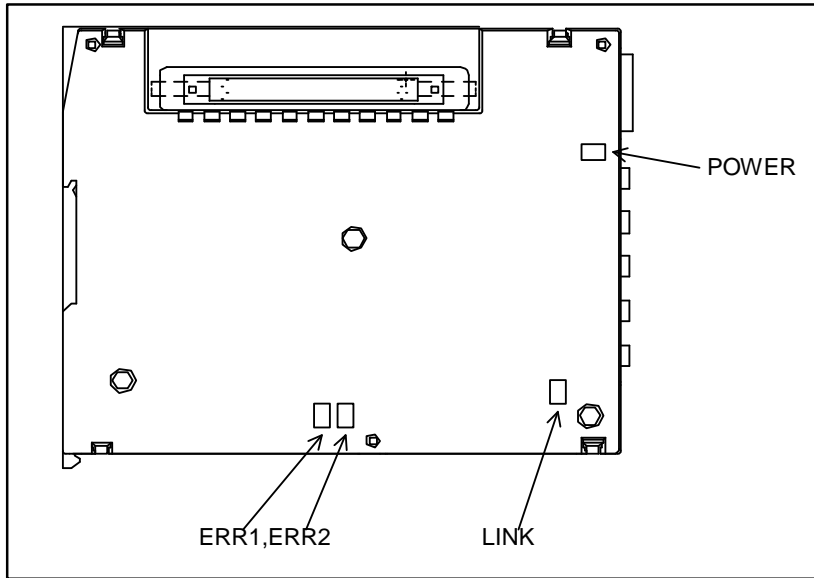

LED indication

No.	LED	Meaning
1	POWER	Turned on when the power is on
2	LINK	Turned on when FSSB communication is performed
3	ERR1	Turned on when COP10A (back stage) is disconnected
4	ERR2	Turned on when COP10B (front stage) is disconnected

## 4.5 Analog Input Separate Detector Interface Unit

### - Specification

Name	Specification
Basic unit	A06B-6061-C202

The additional unit A02B-0323-C204 mentioned in the previous subsection can be used with this interface unit.

### - Connector mounting location

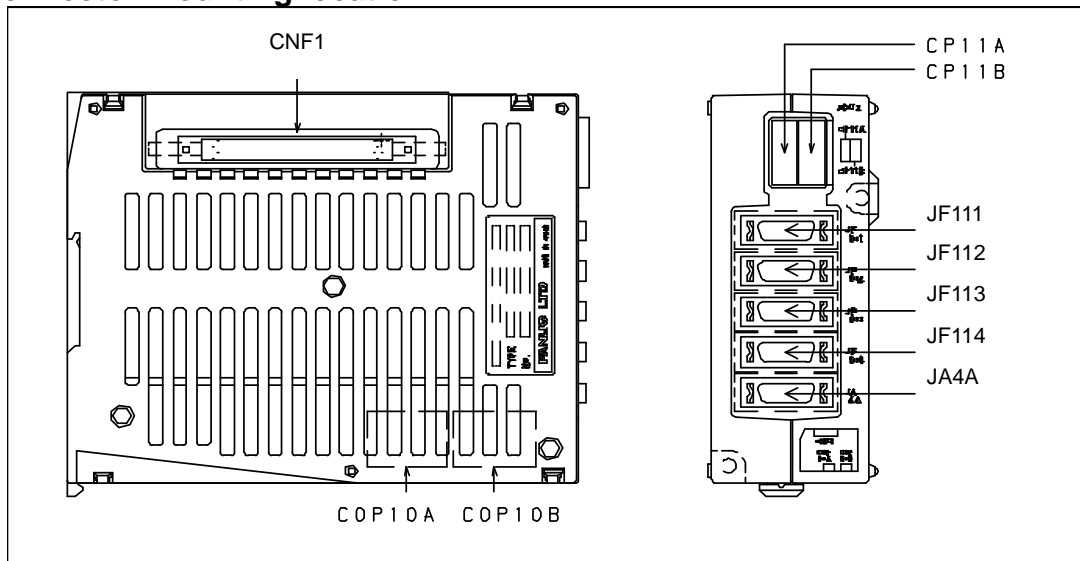

The parenthesized connector names are for the additional unit.

Connector number	Application
CP11A	24 VDC power input
CP11B	24 VDC power output
COP10A	Back stage of the FSSB interface
COP10B	Front stage of the FSSB interface
JF111 to JF114	Separate detector interface
JA4A	Connection of a battery for the absolute detector
CNF1	Connection of the additional unit

### - LED display

Status indication LEDs are installed on the board in the basic unit case. Two green LEDs (POWER and OPEN) and two red LEDs (ERR1 and ERR2) are provided. The locations and meanings of the LEDs are indicated below.

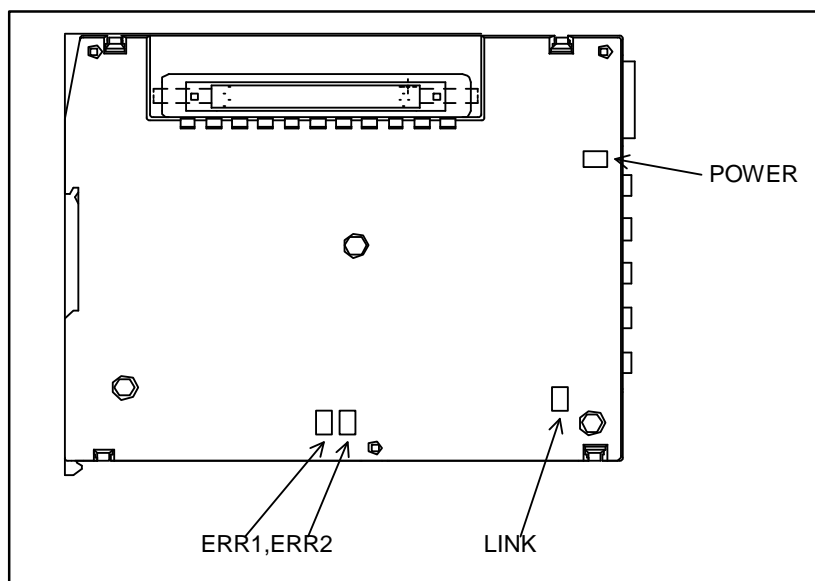

#### LED indication

No.	LED	Meaning
1	POWER	Turned on when the power is on
2	LINK	Turned on when FSSB communication is performed
3	ERR1	Turned on when COP10A (back stage) is disconnected
4	ERR2	Turned on when COP10B (front stage) is disconnected

## 4.6 PANEL *i*

### 4.6.1 Replacing the Battery

The BIOS settings for the PANEL *i* are held in the LSI device on the PANEL *i* main board. The power for this LSI device is backed up with a backup battery mounted on the PANEL *i*. Even if the main power is interrupted, no data in the LSI device will be lost.

If the battery voltage drops, the BIOS message “CMOS Battery Low” appears on the screen when the power is turned on. If the hardware monitor (HardMntr.exe) has been incorporated normally, the monitor screen automatically opens to display “CMOS Battery : Low” after system start-up. If the alarm is issued, replace the battery as soon as possible.

If the battery voltage drops further, it becomes impossible to back up the BIOS settings, thus making it necessary to clear and re-set all the contents. For this reason, FANUC recommends that the battery be replaced once per year regardless of whether a battery alarm is issued.

Before starting replacement work, get the lithium battery (ordering information: A02B-0200-K102) ready.

To replace the battery, follow the procedure below:

- (1) After keeping the PANEL *i* turned on for at least 5 seconds, turn off the power, and detach it from the panel so that you can work from behind.
- (2) Remove the connector from the lithium battery and take out the battery from the battery holder.
- (3) Insert a new battery into the connector (BAT1) within 5 minutes, and put it into the battery holder.
- (4) Re-install the PANEL *i*.
- (5) Turn on the power, and make sure that the BIOS parameters are intact (no error occurs at startup).

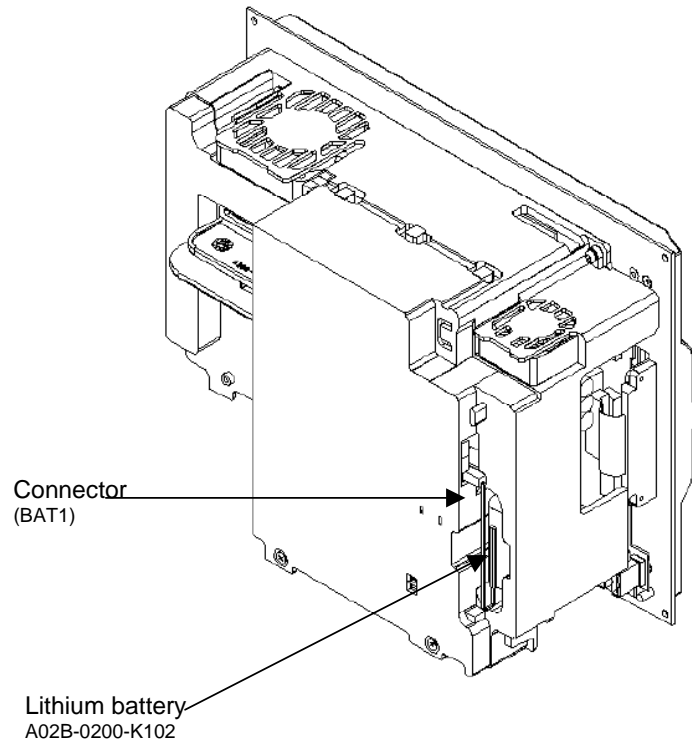

Fig. 4.6.1 Replacing the Battery

**⚠ WARNING**

Using other than the recommended lithium battery may result in the battery exploding. Replace the battery only with the specified lithium battery (A02B-0200-K102).

**⚠ CAUTION**

Insert a new battery within 5 minutes after the old battery is removed from the connector.  
Usually, following the battery replacement procedure stated below will not lose the BIOS settings. Should they be lost, the messages "251: System CMOS checksum bad – Default configuration used." and "Press <F2> to enter SETUP" appear when the power is turned on.  
If you have been using non-default BIOS settings for the PANEL *i*, re-set them up exactly. Usually, the unit is used with the default settings.

**NOTE**

After replacement, dispose the used battery as “industrial waste” correctly according to the laws of the country where the machine is installed and the ordinances of the local government having jurisdiction over the site of the machine. When disposing the battery, insulate it, for example, by taping its electrodes in order to prevent a short circuit.

## 4.6.2 Replacing the Fan

### 4.6.2.1 Replacing the fan in the PANEL *i*

- (1) Turn off the power to the PANEL *i*.
- (2) Get a new fan ready.
- (3) Detach the connector from the fan in the PANEL *i*. The connector is latched. Pull it out by unlatching it with a flat-blade screwdriver as shown below.
- (4) Replace the fan. Be careful not to mount it in the wrong orientation.
- (5) Attach the connector of the new fan correctly; 60-mm-square fan (A08B-0084-K101) to CPE11B and 40-mm-square fan (A08B-0084-K100) to CPB11.

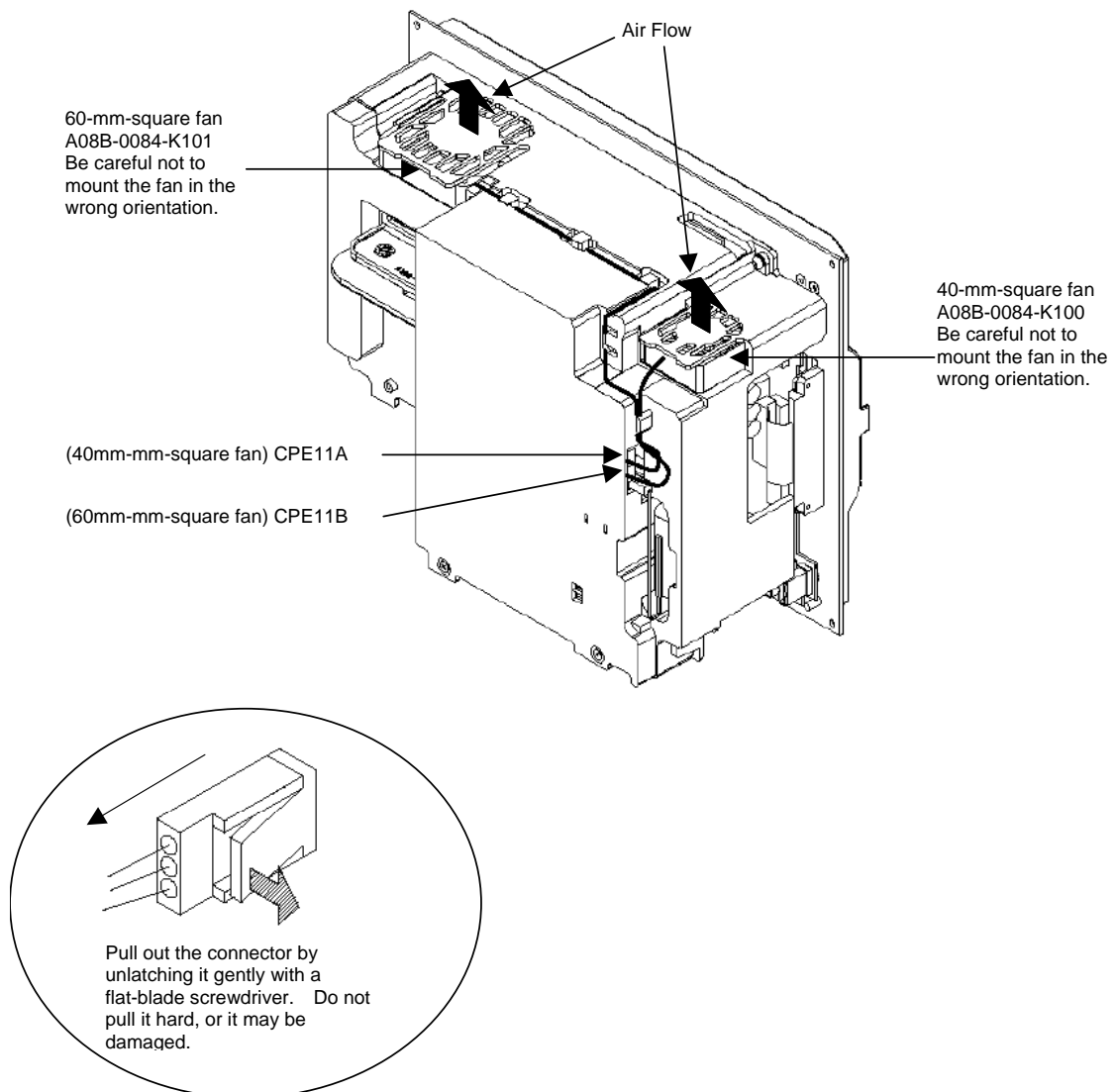

Fig. 4.6.2(a) Replacing the Fan

### 4.6.2.2 Replacing the fan for the HDD

- (1) Turn off the power to the PANEL *i*.
- (2) Get a new fan ready.
- (3) Remove the fan connector (CPE11C) from the power supply board. The connector is latched. Detach it by pulling it up slightly to unlatch.
- (4) Remove the two fastening screws from the fan to detach the fan.
- (5) Fasten the new fan with two screws. Attach it to the connector (CPE11C). Be careful not mount it in the wrong orientation.

#### NOTE

Before replacing a fan in a unit designed to the automotive manufacturer's specification, remove the HDD unit.

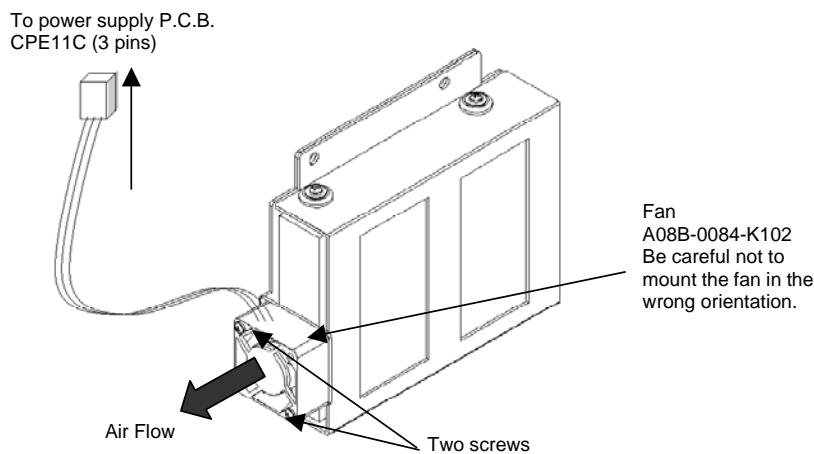

Fig. 4.6.2(b) Replacing the fan for the HDD

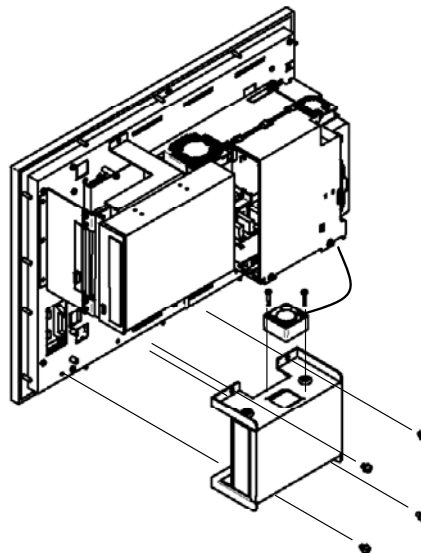

Fig. 4.6.2 (c) Replacing the fan for the HDD (for unit designed to automotive manufacturer's specification)

### 4.6.3 Replacing the Touch Panel Protection Sheet

For the PANEL *i* with a touch panel, the surface of the touch panel is covered with the protection sheet to protect it. When there are flaws and contamination on this protection sheet that make the screen hard to read, replace the protection sheet. See Section 3.12 for explanations about how to replace the touch panel protection sheet.

## 4.7 REPLACING BATTERY FOR ABSOLUTE PULSECODERS

### 4.7.1 Overview

- When the voltage of the batteries for absolute Pulsecoders becomes low, alarm 307 or 306 occurs, with the following indication in the CNC state display at the bottom of the CNC screen.  
Alarm 307 (alarm indicating the voltage of the battery becomes low) :  
The indication "APC" blinks in reversed display.  
Alarm 306 (battery zero alarm) :  
The indication "ALM" blinks in reversed display.
- When alarm 307 (alarm indicating the voltage of the battery becomes low) occurs, replace the battery as soon as possible. In general, the battery should be replaced within one or two weeks, however, this depends on the number of Pulsecoders used.
- When alarm 306 (battery zero alarm) occurs, Pulsecoders are reset to the initial state, in which absolute positions are not held. Alarm 300 (reference position return request alarm) also occurs, indicating that reference position return is required.
- In general, replace the batteries periodically within the service life listed below.
  - A06B-6050-K061 or D-size alkaline dry cells (LR20): Two years (for each six-axis configuration)
  - A06B-6114-K504 : One year (for each three-axis configuration)

#### NOTE

The above values indicate the estimated service life of batteries used with FANUC absolute Pulsecoders. The actual battery service life depends on the machine configuration based on, for example, detector types. For details, contact the machine tool builder.

### 4.7.2 Replacing Batteries

To prevent absolute position information in absolute Pulsecoders from being lost, turn on the machine power before replacing the battery. The replacement procedure is described below.

- <1> Ensure that the power to the servo amplifier is turned on.
- <2> Ensure that the machine is in the emergency stop state (the motor is inactive).
- <3> Ensure that the DC link charge LED of the servo amplifier is off.
- <4> Detach the old batteries and attach new ones.

The replacement of the batteries in a separate battery case and the replacement of the battery built into the servo amplifier are described below in detail.

**⚠ WARNING**

- The absolute Pulsecoder of each of the  $\alpha i/\alpha i$  S series servo motors and the  $\beta i$  S series servo motors ( $\beta i$  S0.4 to  $\beta i$  S22) has a built-in backup capacitor. Therefore, even when the power to the servo amplifier is off and the batteries are replaced, reference position return is not required if the replacement completes within less than 10 minutes. Turn the power on and replace the batteries if the replacement will take 10 minutes or more.
- To prevent electric shock, be careful not to touch metal parts in the power magnetics cabinet when replacing the batteries.
- Because the servo amplifier uses a large-capacitance electrolytic capacitor internally, the servo amplifier remains charged for a while even after the power is turned off. Before touching the servo amplifier for maintenance or other purposes, ensure your safety by measuring the residual voltage in the DC link with a tester and confirming that the charge indication LED (red) is off.
- Be sure to replace the batteries with specified ones. Pay attention to the battery polarity. If a wrong type of battery is used or a battery is installed with incorrect polarity, the battery may overheat, blow out, or catch fire, or the absolute position information in the absolute Pulsecoders may be lost.
- Ensure that the battery connector is inserted in the correct position.

### 4.7.3 Replacing the Batteries in a Separate Battery Case

Use the following procedure to replace the batteries in the battery case.

- <1> Loosen the screws on the battery case and detach the cover.
- <2> Replace the batteries in the case (pay attention to the polarity).
- <3> Attach the cover to the battery case.

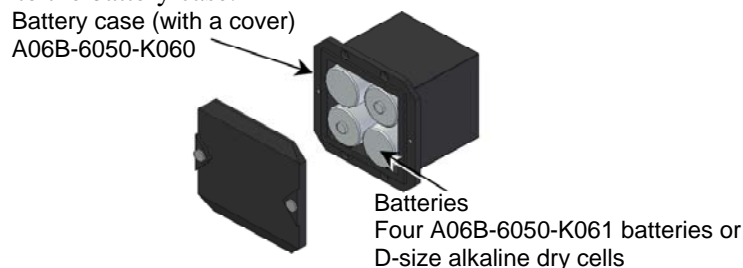
**⚠ CAUTION**

- Four D-size alkaline dry cells (LR20) that are commercially available can be used as batteries. A set of four A06B-6050-K061 batteries is optionally available from FANUC.
- Replace all the four batteries with new ones. If old and new batteries are mixed, the absolute position information in the absolute Pulsecoders may be lost.

### 4.7.4 Replacing the Battery Built into the Servo Amplifier

Use the following procedure to replace the special lithium battery.

- <1> Detach the battery cover.
- <2> Replace the special lithium battery.
- <3> Attach the battery cover.

**⚠ CAUTION**

- Purchase the battery from FANUC because it is not commercially available. It is therefore recommended that you have a backup battery.
- When the built-in battery is used, do not connect BATL (B3) of connector CXA2A/CXA2B. Also, do not connect two or more batteries to the same BATL (B3) line. These connections are dangerous because battery output voltages may be short-circuited, causing the batteries to overheat.
- Install the battery in the servo amplifier in a direction that allows slack in the cable. If the battery cable is under tension, a bad connection may occur.
- If the +6 V pin and 0 V pin are short-circuited, the battery may overheat, blow out, or catch fire, or the absolute position information in the absolute Pulsecoders may be lost.
- When inserting the connector, align it to the connector pins.

**[Connecting the battery]**

The battery for the  $\beta$ iSV4 and  $\beta$ iSV20 series amplifiers is mounted in the battery case on the underside of each of the amplifiers.

The battery for the other  $\beta$ i series amplifiers and the  $\alpha$ i series amplifiers is mounted at the front of each of the amplifiers.

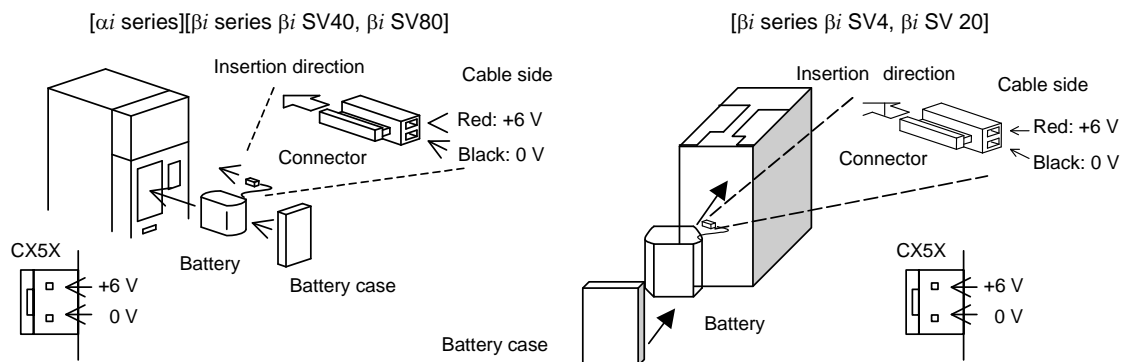

**[Battery sets and outlines]**

Battery ordering drawing number	Applicable servo amplifier	Battery case ordering drawing number	Outline
A06B-6114-K504	$\alpha$ i series 60/90 mm width	A06B-6114-K505	
	$\alpha$ i series 150/300 mm width	A06B-6114-K506	
	$\beta$ i series $\beta$ i SV (two-axis model)	A06B-6114-K505	
A06B-6093-K001	$\beta$ i series $\beta$ iSV4, $\beta$ iSV20	A06B-6093-K002	
	$\beta$ i series $\beta$ iSV40, $\beta$ iSV80	A06B-6093-K002	

**Used batteries**

Old batteries should be disposed as "INDUSTRIAL WASTES" according to the regulations of the country or autonomy where your machine has been installed.



# 5 INPUT AND OUTPUT OF DATA





After you change a FROM/SRAM module, you must set various data again. This chapter explains how to input data (such as parameters, part programs, and tool offset values) to external I/O devices (such as a floppy disk drive) and to output it from them.

5.1 SETTING PARAMETERS FOR INPUT/OUTPUT .....319  
 5.2 INPUTTING/OUTPUTTING DATA .....320  
 5.3 AUTOMATIC DATA BACKUP.....327



## 5.1 SETTING PARAMETERS FOR INPUT/OUTPUT

### Setting procedure of parameters

Parameter writing is enabled with following steps 1 to 3.

- 1 Set to MDI mode or emergency stop state.
- 2 Press function key  several times or press soft key [SETTING] to display SETTING (HANDY) screen.
- 3 Set the cursor to PARAMETER WRITE and, press  and  keys in this order. Here alarm 100 will be displayed.
- 4 Press function key  several times to display the following screen.



PARAMETER	(SETTING)	O1234 N12345
0000	SEQ	INI ISO TVC
	0 0 0 0 0 0 0 0	
0001		FCV
	0 0 0 0 0 0 0 0	
0012	RMV	MIR
X	0 0 0 0 0 0 0 0	
Y	0 0 0 0 0 0 0 0	
Z	0 0 0 0 0 0 0 0	
B	0 0 0 0 0 0 0 0	
0020	I/O CHANNEL	
		S 0 T0000
REF	**** ** *	10: 15: 30
[ F SRH ] [ READ ] [ PUNCH ] [DELETE ] [ ]		

To make the cursor display in bit unit, press the cursor key  or .

- 5 Press soft key [(OPRT)] and the following operation menu is displayed.
  - <1> Soft key [NO. SRH] : Searched by number.  
 Examination) Parameter number → [NO. SRH].
  - <2> Soft key [ON : 1] : Item with cursor position is set to 1 (bit parameter)
  - <3> Soft key [OFF : 0] : Item with cursor position is set to 0 (bit parameter)
  - <4> Soft key [+INPUT] : Input value is added to the value at cursor (word type)
  - <5> Soft key [INPUT] : Input value is replaced with the value at cursor (word type)
  - <6> Soft key [READ] : Parameters are input from reader/puncher interface.
  - <7> Soft key [PUNCH] : Parameters are output to reader/puncher interface.

6 After the parameters have been input, set PARAMETER WRITE on the SETTING screen to 0. Press  to release alarm 100.



7 Convenient method

<1> To change parameters in bit unit, press cursor key  or , then the cursor becomes bit length and you can set parameters bit by bit (Bit parameter only).

<2> To set data consecutively, use  key.



(Ex.1) 

This key sequence sets data as follows:

	0		1234
0	⇒		4567
0			9999
0			0

(Ex.2) 



This key sequence sets data as follows:

	0		1234
0	⇒		0
0			9999
0			0

<3> To set the same data sequentially, press .

(Ex.1) 

This key sequence sets data as follows:

	0		1234
0	⇒		1234
0			1234
0			0

<4> Bit parameters can be set as follows:

(Ex.1) 

This key sequence sets data as follows:

0000		0000	⇒	00011000
00000000		00000000		00011000
00000000		00000000		00011000
00000000		00000000		00000000

8 After the required parameters are set, set PARAMETER WRITE to 0.

## 5.2 INPUTTING/ OUTPUTTING DATA

The CNC memorized the following data.

Outputting the data I/O device while the CNC is running normally.

- (1) CNC parameter
- (2) PMC parameter
- (3) Pitch error compensation amount
- (4) Custom macro variable values
- (5) Tool compensation amount
- (6) Part program (machining program, custom macro program)

## 5.2.1 Confirming the Parameters Required for Data Output

Be sure that data output cannot be done in an alarm status.

Parameters required for output are as follows :

In addition, (\*) indicates the standard setting for input/output devices made by FANUC. Change these settings according to the unit you actually use.

(Parameter can be changed in MDI mode or emergency stop status.)

	#7	#6	#5	#4	#3	#2	#1	#0
0000							ISO	

- ISO 0: Output with EIA code
- 1: Output with ISO code (FANUC cassette)

**NOTE**

- 1 The I/O setting of a memory card is made by bit 0 (ISO) of parameter No. 0139.
- 2 The I/O setting of an USB memory is made by bit 0 (ISU) of parameter No. 11505.

0020	Selection of I/O channel
------	--------------------------

- (\*) 0: Channel 1 (JD56A of mother board)
- 1: Channel 1 (JD56A of mother board)
- 2: Channel 2 (JD36A of mother board)
- 4: Memory card interface
- 17: USB memory interface

**NOTE**

An operation example shown here assumes that data input/ output is performed with an input/output unit connected to the JD56A. (I/O channel = 0)

	#7	#6	#5	#4	#3	#2	#1	#0
0101	NFD			ASI				SB2

- NFD 0: Feed is output when data is output.
- 1: Feed is not output when data is output.
- ASI(\*) 0: EIA or ISO code is used for input/output data.
- 1: ASCII code is used.
- SB2 0: No. of stop bits is 1.
- (\*) 1: No. of stop bits is 2.

0102	Number specified for the input/output device
------	--

Set value	Input/output device
0	RS-232-C (Used control codes DC1 to DC4)
1	FANUC CASSETTE ADAPTOR 1 (FANUC CASSETTE B1/B2)
2	FANUC CASSETTE ADAPTOR 3 (FANUC CASSETTE F1)
3	FANUC PROGRAM FILE Mate, FANUC FA Card Adaptor FANUC FLOPPY CASSETTE ADAPTOR, FANUC Handy File FANUC SYSTEM P-MODEL H
4	RS-232-C (Not used control codes DC1 to DC4)
5	Portable tape reader

Set value	Input/output device
6	FANUC PPR FANUC SYSTEM P-MODEL G, FANUC SYSTEM P-MODEL H

0103	Baud Rate		
	1: 50	7: 600	11: 9600
	3: 110	8: 1200	12: 19200 [BPS]
	4: 150	9: 2400	
	6: 300	(*)10:4800	

0139	#7	#6	#5	#4	#3	#2	#1	#0
								ISO

ISO

0: Output with ASCII code  
1: Output with ISO code (memory card)

**⚠ WARNING**

- 1 Unless data is input using ASCII codes, set this parameter to 1 to input or output data using ISO codes.
- 2 Data input/output with ASCII codes is dangerous because parity information is not included and a data error during the data input/output is not detected.
- 3 DNC operation from a memory card also must set the parameter to 1, and execute DNC operation by ISO code. ASCII codes is dangerous because parity information is not included and a data error during the data input is not detected.

**NOTE**

A tool (FANUC ISO Converter) for converting data from ASCII code to ISO code on a commercial PC is available from FANUC.

11505	#7	#6	#5	#4	#3	#2	#1	#0
								ISU

ISU

0: Output with ASCII code  
1: Output with ISO code (USB memory)

**⚠ WARNING**

- 1 Unless data is input using ASCII codes, set this parameter to 1 to input or output data using ISO codes.
- 2 Data input/output with ASCII codes is dangerous because parity information is not included and a data error during the data input/output is not detected.

**NOTE**



A tool (FANUC ISO Converter) for converting data from ASCII code to ISO code on a commercial PC is available from FANUC.

## 5.2.2 Outputting CNC Parameters

- 1 Enter EDIT mode or the emergency stop condition.
- 2 Press function key  and soft key [PARAMETER] to select a parameter screen.



- 3 Press soft key [(OPRT)] and continuous menu key .
- 4 Press soft key [PUNCH] and [EXEC], and the parameters are started to be output.

### 5.2.3 Outputting Pitch Error Compensation Amount



- 1 Select EDIT mode.
- 2 Press the function key  and continuous menu key  several times, then press [PITCH] to select the pitch error compensation setting screen.
- 3 Press soft key [(OPRT)] and continuous menu key .
- 4 Press soft key [PUNCH] and [EXEC], then pitch error compensation amount is started to be output.

### 5.2.4 Outputting Custom Macro Variable Values

When custom macro function is equipped, values of variable No. 500 and later are output.

- 1 Press function key .
- 2 Press continuous menu key  and soft key [MACRO] to select custom macro variable screen.
- 3 Press soft key [(OPRT)] and then continuous menu key .
- 4 Press soft key [PUNCH] and [EXEC], then custom macro variable values are output.

### 5.2.5 Outputting Tool Compensation Amount









- 1 Select EDIT mode.
- 2 Press function key  and soft key [OFFSET] to display the tool compensation amount screen.
- 3 Press [(OPRT)] key and continuous menu key .
- 4 Press soft key [PUNCH] an [EXEC] key, and the tool compensation amount is started to be output.

### 5.2.6 Outputting Part Program

- 1 Confirm the following parameters. If this parameter is set to 1, rather than the value indicated by 1, change to MDI mode and then reset to 0.  
However, if you changed the parameter setting, restore the original value after finishing this work.

	#7	#6	#5	#4	#3	#2	#1	#0
3202				NE9				NE8

- NE9(\*) 0: Programs of 9000s are edited.  
1: Programs of 9000s can be protected. (Protected programs are not output.)
- NE8 (\*) 0: Programs of 8000s are edited.  
1: Programs of 8000s can be protected.  
(Protected programs are not output.)

- 2 Select EDIT mode.
- 3 Press function key  and press soft key [PROGRAM] to display program text.
- 4 Press [(OPRT)] key and press continuous menu key .
- 5 Input a program number to be output. To output all programs input as:  
      
- 6 Press [PUNCH] and [EXEC] key, then program output is started.

## 5.2.7 Inputting CNC Parameters

- 1 Set to the emergency stop state.
- 2 Confirm that the parameters required to input data is correct.  
In addition, (\*) indicates the standard setting for input/output devices made by FANUC. Change these settings according to the unit you actually use.

<1> Press function key  several times, and press [SETTING] to display SETTING screen.

<2> Confirm that PARAMETER WRITE=1.

<3> Press function key  to select the parameter screen.

<4>

<b>0020</b>	<b>Selection of I/O channel</b>
(*) 0:	Channel 1 (JD56A of mother board)
1:	Channel 1 (JD56A of mother board)
2:	Channel 2 (JD36A of mother board)
4:	Memory card interface
17 :	USB memory interface

<5>

	<b>#7</b>	<b>#6</b>	<b>#5</b>	<b>#4</b>	<b>#3</b>	<b>#2</b>	<b>#1</b>	<b>#0</b>
<b>0101</b>	<b>NFD</b>				<b>ASI</b>			<b>SB2</b>

- NFD 0: Feed is output when punching out.  
1: Feed is not output when punching out.
- ASI 0: EIA or ISO code is used.  
1: ASCII code is used.
- SB2 0: No. of stop bits is 1.  
(\*) 1: No. of stop bits is 2.

<6>

<b>0102</b>	<b>Specification number of I/O device</b>
Set value	Input/output device
0	RS-232-C (Used control codes DC1 to DC4)
1	FANUC CASSETTE ADAPTOR 1 (FANUC CASSETTE B1/B2)
2	FANUC CASSETTE ADAPTOR 3 (FANUC CASSETTE F1)
3	FANUC PROGRAM FILE Mate, FANUC FA Card Adaptor FANUC FLOPPY CASSETTE ADAPTOR, FANUC Handy File FANUC SYSTEM P-MODEL H
4	RS-232-C (Not used control codes DC1 to DC4)
5	Portable tape reader
6	FANUC PPR FANUC SYSTEM P-MODEL G, FANUC SYSTEM P-MODEL H

<7>

<b>0103</b>	<b>Baud rate</b>
1: 50	7: 600
3: 110	8: 1200
4: 150	9: 2400
6: 300	(*)10: 4800
	11: 9600
	12: 19200 [BPS]

- 3 Press continuous menu key .
- 4 Press soft key [READ] and [EXEC]. Then input of parameters are started.

- 5 Upon completion of parameter input, turn off the power then turn on the power again.
- 6 Alarm 300 is issued if the system employs an absolute pulse coder. In such a case, perform reference position return again.

<b>0139</b>	#7	#6	#5	#4	#3	#2	#1	#0
ISO								ISO

0: Output with ASCII code  
1: Output with ISO code (memory card)

**⚠ WARNING**

- 1 Unless data is input using ASCII codes, set this parameter to 1 to input or output data using ISO codes.
- 2 Data input/output with ASCII codes is dangerous because parity information is not included and a data error during the data input/output is not detected.
- 3 DNC operation from a memory card also must set the parameter to 1, and execute DNC operation by ISO code. ASCII codes is dangerous because parity information is not included and a data error during the data input is not detected.

**NOTE**

A tool (FANUC ISO Converter) for converting data from ASCII code to ISO code on a commercial PC is available from FANUC.

<b>11505</b>	#7	#6	#5	#4	#3	#2	#1	#0
ISU								ISU

0: Output with ASCII code  
1: Output with ISO code (USB memory)





**⚠ WARNING**



- 1 Unless data is input using ASCII codes, set this parameter to 1 to input or output data using ISO codes.
- 2 Data input/output with ASCII codes is dangerous because parity information is not included and a data error during the data input/output is not detected.

**NOTE**





A tool (FANUC ISO Converter) for converting data from ASCII code to ISO code on a commercial PC is available from FANUC.

## 5.2.8 Inputting Pitch Error Compensation Amount



- 1 Release the emergency stop and select EDIT mode.
- 2 Confirm that PARAMETER WRITE=1 on the setting screen.
- 3 Press function key  and soft key [PROGRAM] to display program contents.
- 4 Press function key  several times, soft key [PARAM], continuous menu key  and [PITCH] to select the screen for pitch error compensation amount.
- 5 Press the function key  and continuous menu key  several times, then press [PITCH] to select the pitch error compensation setting screen.

- 6 Press soft key [(OPRT)] and continuous menu key .
- 7 Press soft key [READ] and [EXEC], then the pitch error compensation amount is started to be input.
- 8 After data has been input, press function key  twice to display the SETTING screen and return the PARAMETER WRITE to 0.

## 5.2.9 Inputting Custom Macro Variable Values

- \* If the system is equipped with the custom macro function, input the variable values.
- 1 Select EDIT mode.
  - 2 Press function key  then soft key [PROGRAM] to display program contents.
  - 3 Press the function key  and press continuous menu key  several times, then press [PITCH] to select the pitch error compensation setting screen.
  - 4 Press soft key [(OPRT)] and continuous menu key .
  - 5 Press soft key [READ] and [EXEC], then the pitch error compensation amount is started to be input.

## 5.2.10 Inputting Tool Compensation Amount

- 1 Select EDIT mode.
- 2 Turn off the program protect (KEY=1).
- 3 Press function key , and soft key [OFFSET] to display the tool compensation amount screen.
- 4 Press soft key [(OPRT)] and continuous menu key .
- 5 Press [READ] key and [EXEC] key and data input is started.

## 5.2.11 Inputting Part Programs

Confirm the following parameters. If the setting is different from the value indicated by (\*), reset to the specified value only during this work. (Change it in MDI mode).

	#7	#6	#5	#4	#3	#2	#1	#0
3201		NPE					RAL	

NPE When programs are registered in part program storage area, M02,M30 and M99 are:

0: Regarded as the end of program.

(\*) 1: Not regarded as the end of program.

RAL When programs are registered:

(\*) 0: All programs are registered.

1: Only one program is registered.

	#7	#6	#5	#4	#3	#2	#1	#0
3202				NE9				NE8

NE9 (\*) 0: Programs of 9000s can be edited.

1: Programs of 9000s are protected.

NE8 (\*) 0: Programs of 8000s can be edited.

1: Programs of 8000s are protected.

\* For PPR, item 4 is not required.

1 Confirm that mode is EDIT mode.

2 Turn off the program protect (KEY3=1).



- 3 Press function key  and press soft key [PROGRAM] to select a part program file.
- 4 Press soft key [READ] and [EXEC], then data input is started.

## 5.3 AUTOMATIC DATA BACKUP

It is possible to back up data held in the CNC's FROM/SRAM by storing it automatically in the FROM, which requires no battery and to restore the backed-up data as required. If data is lost from the CNC due to unforeseen circumstances, this function can be used to restore the data easily.

Also, it is possible to hold up to three occurrences of backup data. With this function, the CNC data can be quickly switched to a post-machine adjustment state or an arbitrary backup state.

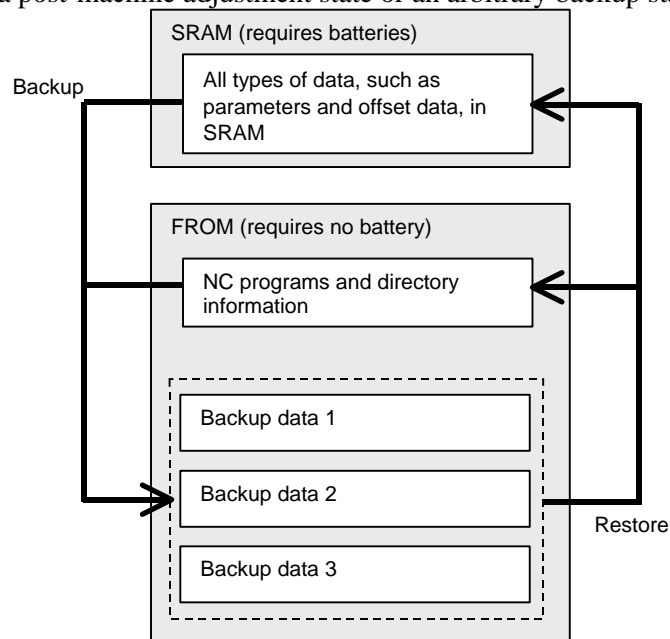

### Explanation

#### - Data to be backed up

Data in the CNC is backed up by storing it in the FROM, which requires no battery.

- NC programs and directory information held in the FROM (which requires no battery)
- Various types of data, such as parameters and offset values, held in the SRAM (which requires batteries)

Setting bit 2 (AAP) of parameter No.10340 to 1 enables NC programs and directory information in the FROM to be backed up. Set this parameter only when necessary, because the required backup time and data storage size vary depending on the size of the programs.

Setting parameter No. 10342 enables up to 3 occurrences of backup data to be held.

#### - Backup modes

The following three backup modes are available.

1. Automatic backup occurring every time the power is turned on
2. Automatic backup occurring at intervals of a specified number of days when the power is turned on
3. Backup started manually at an emergency stop

#### - Automatic backup occurring every time the power is turned on

Data in the CNC can be backed up automatically when the power is turned on.

This mode can be used by:

- Setting bit 0 (ABP) of parameter No. 10340 to 1
- Setting parameter No. 10342 to 1 or greater

- Setting bit 2 (AAP) of parameter No. 10340 to 1 if also NC programs and directory information in the FROM must be backed up

#### - **Automatic backup occurring at intervals of a specified number of days when the power is turned on**

Data in the CNC can be backed up automatically when the power is turned on for the first time in a specified number of days since the previous backup.

This mode can be used by:

- Selecting the first backup mode (automatic backup occurring every time the power is turned on)
- Setting parameter No. 10341 with a number of days at intervals of which automatic backup is to be made cyclically

#### - **Backup started manually at an emergency stop**

Data in the CNC can be backed up by starting an appropriate procedure manually in an emergency stop state. This mode makes it possible to back up data without turning off the power for the CNC at an arbitrary timing, such as when machining has been set up or before a holiday.

This mode can be used by:

- Setting parameter No. 10342 to 1 or greater
- Setting bit 2 (AAP) of parameter No. 10340 to 1 if also NC programs and directory information in the FROM must be backed up

[Backup procedure]

1. Put the machine in an emergency stop state.
2. Set bit 7 (EEB) of parameter No. 10340 to 1 to start backup. This parameter becomes 0 just after the backup sequence has started.
3. The execution status of backup can be checked with No. 1016 on the diagnosis screen described later.

#### **NOTE**

It takes time since the beginning of backup till the end of backup. So, if data being backed up is updated, it is likely that a mismatch may occur between the original data and backup data. When updating data in the CNC at an emergency stop, watch the automatic data backup in-progress signal ATBK and perform appropriate processing.

#### - **Backup execution status**

In the backup modes used at power-on time, 10 dots “.” are used to indicate the execution status of backup. For example, the completion of backup is indicated with: “AUTO BACKUP : .....END

The diagnosis screen can also be used to check the execution status of backup as follows:

- No.1016#0 (AEX): Backup in progress
- No.1016#6 (ACM): Backup completed
- No.1016#7 (ANG): Error during backup
- No.1016#1 (DT1), #2 (DT2), #3 (DT3): Updated data

#### - **Write-protected backup data**

Factory-set or post-adjustment machine status data can be held as write-protected backup data by specifying the number of pieces of backup data to 2 or greater with parameter No. 10342. The first piece of backup data is handled as write-protected backup data.

This function is enabled by:

- Setting bit 1 (ABI) of parameter No. 10340 to 1
- Setting parameter No. 10342 to 2 or greater
- Setting bit 2 (AAP) of parameter No. 10340 to 1 if also NC programs and directory information in the FROM must be backed up

[Backup procedure]

1. Set bit 6 (EIB) of parameter No. 10340 to 1.
2. Turn the power for the CNC off and on again. When the power is turned on, the first piece of backup data is updated automatically, and bit 6 (EIB) of parameter No. 10340 becomes 0.

The second and third pieces of backup data are updated each time another type of backup (automatic backup occurring every time the power is turned on, automatic backup occurring at intervals of a specified number of days when the power is turned on, or backup started manually at an emergency stop) is made.

### - Parity check

A parity check is made at backup. If a parity error is detected, the backup is not completed.

### - Restoring backed-up data

With the BOOT SYSTEM, executing the following procedure can restore backed-up data from FROM.

- 1 From the BOOT's TOP menu, select "7. SRAM DATA UTILITY". The following menu appears. Select "3".

```

SRAM DATA UTILITY

1. SRAM BACKUP ( CNC -> MEMORY CARD )
2. SRAM RESTORE ( MEMORY CARD -> CNC )
3. AUTO BKUP RESTORE ( FROM -> CNC )
4. END
  
```

2. From the menu below, select data and run restore.

```

AUTO BACKUP DATA RESTORE

1. BACKUP DATA1 yyyy/mm/dd **:**:**
2. BACKUP DATA2 yyyy/mm/dd **:**:**
3. BACKUP DATA3 yyyy/mm/dd **:**:**
4. END
  
```

3. Exit BOOT.

## Signal

### Automatic data backup in-progress signal ATBK<F0520.0>

[Classification] Output signal

[Function] This signal is "1" during automatic data backup. When updating data in the CNC at an emergency stop, perform appropriate processing according to the state of this signal.

### Signal address

	#7	#6	#5	#4	#3	#2	#1	#0
F0520								ATBK

## Parameter

	#7	#6	#5	#4	#3	#2	#1	#0
10340	EEB	EIB				AAP	ABI	ABP

[Input type] Parameter input

[Data type] System-common type

**#0 ABP** Automatic data backup at power-on is:

0: Disabled.

1: Enabled.

- #1 ABI** Overwrite-protected backup data is:  
 0: Regarded as invalid.  
 1: Regarded as valid.
- #2 AAP** Backup of NC programs and directory information in FROM is:  
 0: Disabled.  
 1: Enabled.
- #6 EIB** When the CNC is turned on next, overwrite-protected backup data is:  
 0: Not updated.  
 1: Updated.

**NOTE**

This parameter is valid when 2 or a greater value is set in parameter No. 10342, and bit 1 (ABI) of parameter No. 10340 is set to 1.

- #7 EEB** When an emergency stop occurs, a backup operation is:  
 0: Not performed.  
 1: Performed.

**NOTE**

This parameter is valid when 1 or a greater value is set in parameter No. 10342.

10341

Interval at which automatic data backup is performed periodically

- [Input type] Parameter input  
 [Data type] Word system-common type  
 [Unit of data] No unit  
 [Valid data range] 0 to 365

When automatic data backup is performed periodically, this parameter sets the interval as the number of days. When the power is turned on after a set number of days has passed from the date of the previous backup, a backup operation is performed. If 0 is set in this parameter, this function is disabled.

10342

Number of backup data items

**NOTE**

When this parameter is set, the power must be turned off before operation is continued.

- [Input type] Parameter input  
 [Data type] Byte system-common type  
 [Unit of data] No unit  
 [Valid data range] 0 to 3

This parameter sets the number of backup data items. If 0 is specified, backup is not performed.

**Diagnosis display**

This function enables the status of backup execution to be checked.

	#7	#6	#5	#4	#3	#2	#1	#0
1016	ANG	ACM			DT3	DT2	DT1	AEX

- #0 AEX** Indicates whether automatic data backup is being executed, as follows:  
 0: Not being executed  
 1: Being executed
- #1 DT1** Indicates whether data 1 has been updated in the previous backup, as follows:  
 0: Not updated  
 1: Updated
- #2 DT2** Indicates whether data 2 has been updated in the previous backup, as follows:  
 0: Not updated  
 1: Updated
- #3 DT3** Indicates whether data 3 has been updated in the previous backup, as follows:  
 0: Not updated  
 1: Updated
- #6 ACM** Indicates whether automatic data backup has been executed, as follows:  
 0: Not executed  
 1: Executed
- #7 ANG** Indicates whether an error has occurred in automatic data backup, as follows:  
 0: Not occurred  
 1: Occurred

## Caution

### CAUTION

- 1 A value that can be set in parameter No. 10342 (number of occurrences of backup data held) is limited according to the program size, SRAM capacity, and the FROM/SRAM module used.
- 2 Do not turn off the power for the NC during backup or restoration.
- 3 If backed-up data is restored, parameters submitted to automatic backup are returned to the state in which they were when backed up. Change them as required.

# 6 INTERFACE BETWEEN CNC AND PMC

This section briefly describes the PMC function. It also explains the CNC-PMC interface.

6.1	WHAT IS PMC? .....	332
6.2	MULTI-PMC FUNCTION .....	336
6.3	PMC SPECIFICATIONS.....	346
6.4	OPERATING THE PMC SCREEN.....	352
6.5	PMC DIAGNOSIS AND MAINTENANCE SCREENS ([PMC MAINTEN]) .....	355
6.6	LADDER DIAGRAM MONITOR AND EDITOR SCREENS ([PMC LADDER]) .....	384
6.7	LIST OF ADDRESSES .....	398

## 6.1 WHAT IS PMC?

The programmable machine controller (PMC) is a programmable controller (PC) built into a CNC to perform sequence control for a machine tool (spindle rotation, tool change, machine operator's panel control, and so on).

Sequence control is to perform control steps successively in a predetermined sequence or according to the logic operation.

Programs for performing sequence control for machine tools are called sequence programs. Generally, sequence programs coded in the Ladder language are used.

### 6.1.1 Basic Configuration of PMC

The Fig. 6.1.1 is the basic configuration of the PMC:

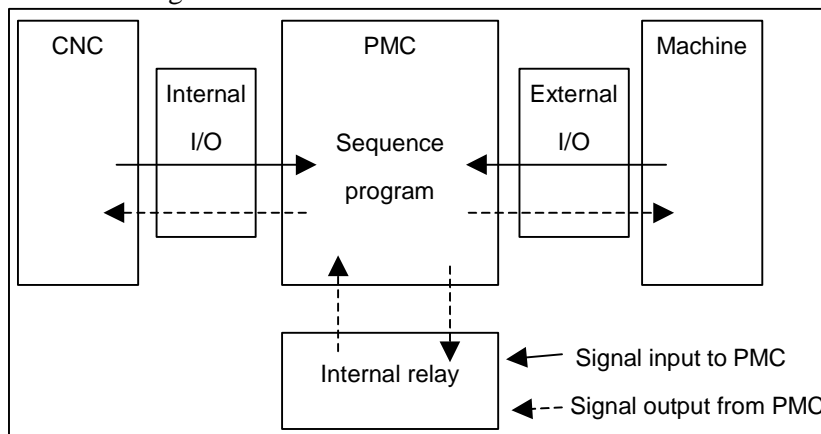

Fig. 6.1.1 Basic configuration of PMC

The sequence program reads input signals, performs operations, and outputs results in a predetermined sequence.

### 6.1.2 I/O Signals of PMC

Input signals of the PMC include signals input from the CNC (such as M and T function signals) and signals input from the machine (such as the cycle start button and feed hold signal button). Output signals of the PMC include signals output to the CNC (such as the cycle start command and feed hold signal command) and signals output to the machine (such as turret rotation and spindle stop). The PMC controls these I/O signals by executing a sequence program to control the machine tool.

### 6.1.3 PMC Signal Addresses

PMC signal addresses indicate the locations of I/O signals exchanged with the machine, I/O signals exchanged with the CNC, and signals for internal relays and data (PMC parameters) in nonvolatile memory.

PMC addresses are roughly classified as shown in Fig. 6.1.3 (a).

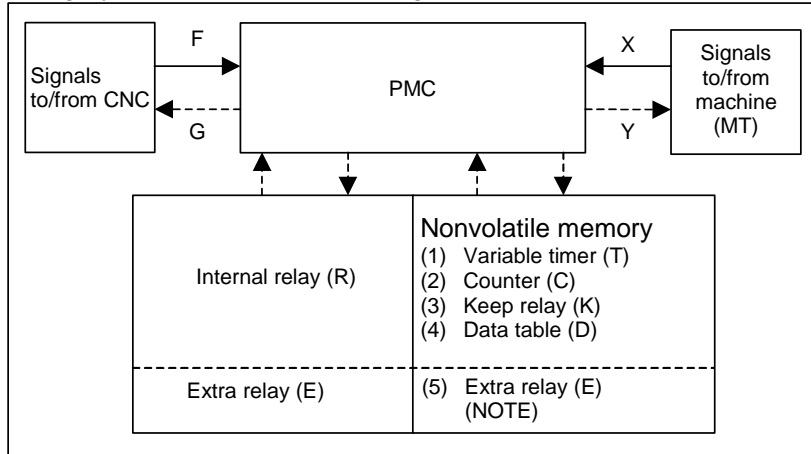

Fig. 6.1.3 (a) PMC-related addresses

**NOTE**

Optionally, extra relays (E) may be assigned to nonvolatile memory locations.

The PMC signal address format consists of an address number and bit number (0 to 7) as follows (Fig. 6.1.3 (b)):

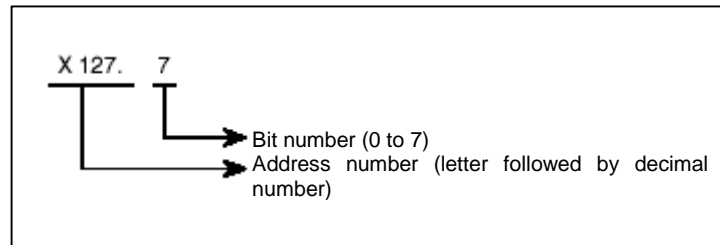

Fig. 6.1.3 (b) PMC address format

The first letter of an address number represents the type of the signal.

In sequence programs, an address of a byte may be specified. In the above example, specify X127 to specify a byte address. In this case, the period "." and bit number are unnecessary.

Table 6.1.3 lists the address symbols and corresponding signals.

Table 6.1.3 Address Symbols and signal types

Symbol	Signal type
F	Input signal from CNC to PMC (CNC → PMC)
G	Output signal from PMC to CNC (PMC → CNC)
X	Input signal from machine to PMC (MT → PMC)
Y	Output signal from PMC to machine (PMC → MT)
R	Internal relay
E	Extra relay
Z	System relay
A	Message display
T	Variable timer
C	Counter

Symbol	Signal type
K	Keep relay
D	Data table
M	Input signal from another PMC path
N	Output signal to another PMC path
L	Label number
P	Subprogram number

- (1) Addresses of signals between the PMC and CNC (F and G)  
 These addresses are assigned to interface signals between the CNC and PMC. The relationships between the signals and addresses are defined by the CNC.  
 F indicates an input signal from the CNC to PMC.  
 G indicates an output signal from the PMC to CNC.
- (2) Addresses of signals between the PMC and machine (X and Y)  
 I/O signals exchanged with an externally connected machine can be assigned to any addresses within an available range to control the machine.  
 X indicates an input signal from the machine to PMC.  
 Y indicates an output signal from the PMC to machine.
- (3) Addresses of internal relays and extra relays (R and E)  
 These addresses are used to temporarily store operation results during sequence program execution processing.  
 Optionally, E addresses may be assigned to nonvolatile memory locations.  
 The address locations of internal relays also include a reserved area used by the PMC system software. The signals in the reserved area cannot be written by sequence programs.
- (4) System Relay Addresses (Z)  
 The System Relay is used to control a sequence program by PMC System software. And, some addresses such as 'Operation results of functional instructions' are used to condition of a sequence program.  
 For PMC memories A and B, the system relay addresses are R9000 to R9499.
- (5) Signal addresses for message display (A)  
 Instruction "DISPB" used in sequence programs include instructions to display a message on the CNC screen. These addresses are used by such instructions.
- (6) Nonvolatile memory addresses  
 The contents of these address locations are not erased even when the power is turned off.  
 These addresses are used for management of the data items listed below. These data items are called PMC parameters.
  - (a) Variable timer (T)
  - (b) Counter (C)
  - (c) Keep relay (K)  
 A reserved area used by the PMC system software is partly included.
  - (d) Data table (D)
  - (e) Extra relay (E)  
 Optionally, E addresses may be assigned to nonvolatile memory locations.  
 These addresses are used to temporarily store operation results during sequence program execution processing.
- (7) Addresses for multi-path PMC Interface (M, N)  
 These addresses are used to the Multi-path PMC interface.



M indicates an input signal from another PMC path.

N indicates an output signal to another PMC path.

(8) Other addresses

(a) Label number (L)

Sequence program instructions include an instruction to cause a jump to a specified position in the middle of processing. This address indicates the jump destination used by this instruction. The contents of L address can not be read/written in sequence program.

(b) Subprogram number (P)

In sequence programs, a main program can call subprograms. P addresses indicate the numbers of these subprograms. The contents of P address can not be read/written in sequence program.

## 6.1.4 Communication Method for External I/O Device

For the high-speed serial interface, which passes input/output signals between the PMC and each I/O device, there are two communication methods, i.e. the FANUC I/O Link *i* and the FANUC I/O Link.

You can use up to three channels for the serial interface. The communication method for channel 1 and channel 2 can be specified by the CNC parameter. The default value “0” of the CNC parameter means that I/O Link is specified. The channel 3 can be used only for I/O Link.

For the details of the setting of the CNC parameter, see PMC PROGRAMMING MANUAL (B-64513EN).

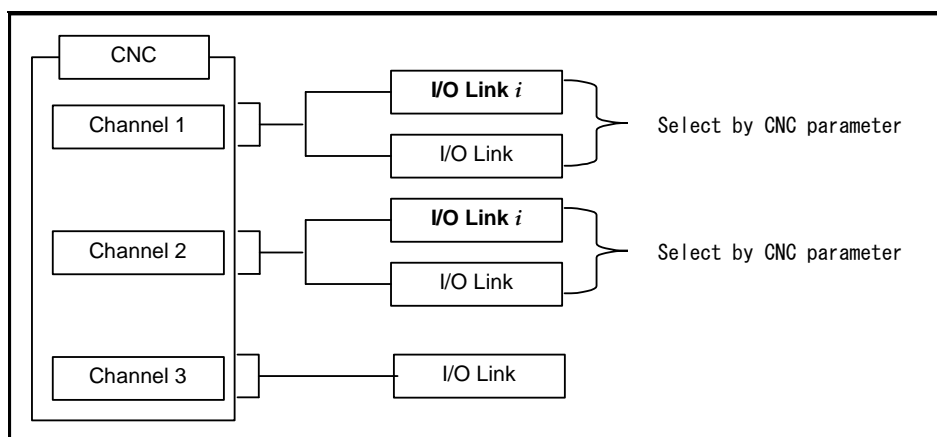

Fig. 6.1.4(c) Setting of the communication method for each channels

The maximum I/O points of I/O Link *i* are 2048 points/2048 points for each channel. The maximum I/O points of I/O Link are 1024 points/1024 points for each channel. The maximum I/O points for a PMC system are 4096 points/4096 points in total. You can use several channels of I/O Link *i* and I/O Link but the total points cannot exceed the maximum points of the PMC system.

[The example of combination of I/O Link *i* and I/O Link]

Channel 1	Channel 2	Channel 3	Total points (DI / DO)
I/O Link <i>i</i>	I/O Link <i>i</i>	—	4096 / 4096
I/O Link <i>i</i>	I/O Link	I/O Link	4096 / 4096
I/O Link <i>i</i>	I/O Link	—	3072 / 3072
I/O Link	I/O Link	I/O Link	3072 / 3072
I/O Link <i>i</i>	—	—	2048 / 2048
I/O Link	I/O Link	—	2048 / 2048
I/O Link	—	I/O Link	2048 / 2048
I/O Link	—	—	1024 / 1024

## 6.2 MULTI-PMC FUNCTION

The multi-PMC function allows one PMC system to execute multiple sequence programs at the same time.

PMC memory for each sequence program is basically independent, and the same PMC address can be used for different purposes of the individual PMCs. Extra relays (E addresses) can be shared among PMCs as shared memory. All PMCs can read from and write to this area, so the area can be used for the interface between the PMCs. M,N addresses can be also used for the interface between the PMCs.

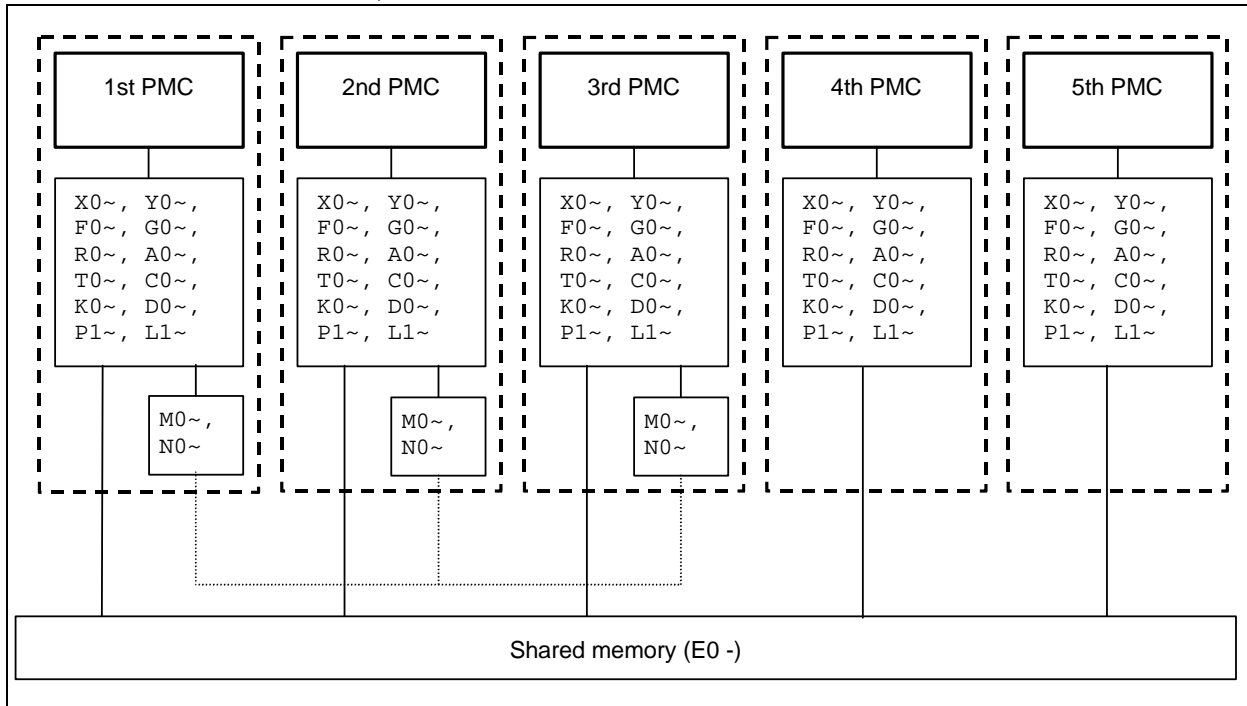

Fig. 6.2 (a) PMC memory of multi-PMC function

A program for each PMC is saved as an independent file and can be edited, updated, and backed up separately.

The CNC systems and the I/O Link channels to be controlled by PMCs can be changed by CNC parameter setting. In a parameter-set configuration, one PMC may control all CNC systems, or each PMC may control a different CNC system.

Fig. 6.2 (b) shows a configuration example.

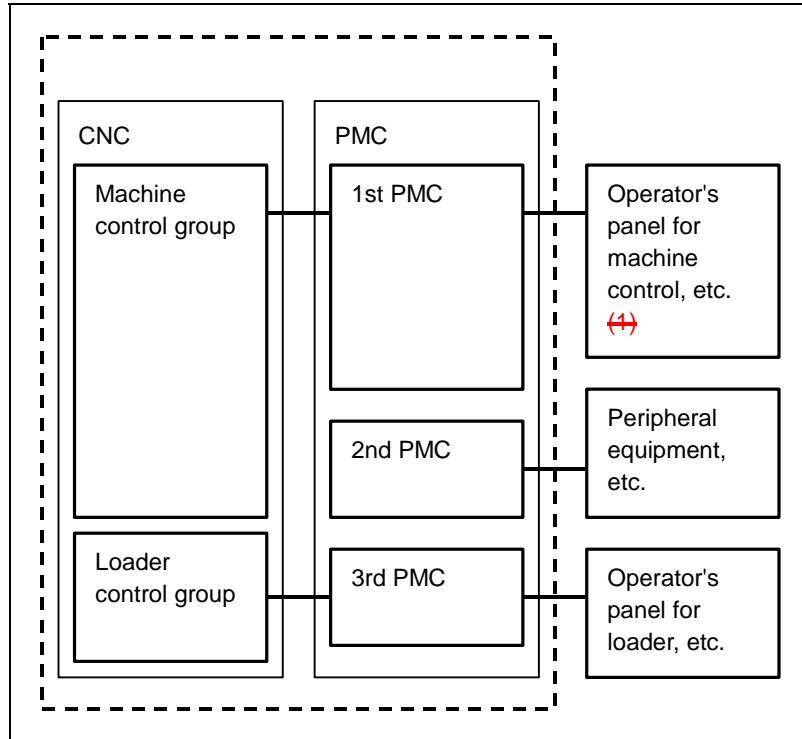

Fig. 6.2 (b) Multi-PMC function configuration example

If the Series 30i/31i/32i-A system is used to control more than one CNC path, some paths can be grouped to share data within a group and to stop all the paths in the group if an alarm condition occurs in one of the paths. The group is referred to as the machine group.

The system supports up to 3 machine groups. Each group has a separate emergency stop signal address. A PMC is basically assigned to each machine group.

### 6.2.1 Execution Order and Execution Time Percentage

For the multi-PMC function, the order of PMC execution and execution time percentages of the PMCs can be set with CNC parameters.

#### Execution order

If parameters related to the execution order are not set (0 is set), the order sequence is assumed by default:

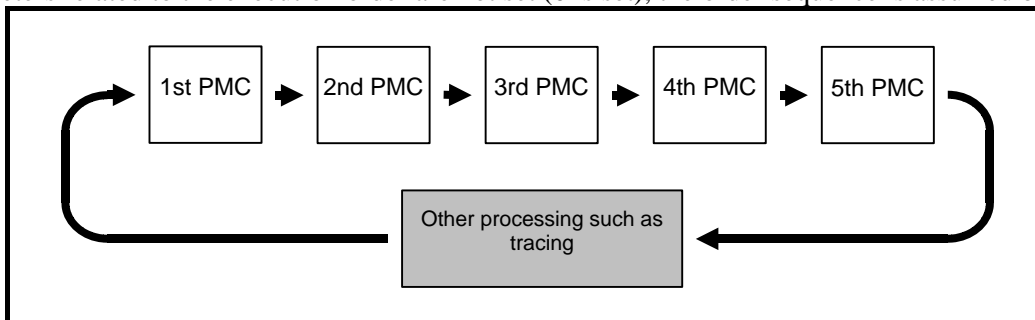

Fig. 6.2.1 (a) Default execution order of multiple PMCs

#### Execution time percentage

If parameters related to execution time percentages are not set (0 is set), the execution time percentages (Table 6.2.1 (a)) are assumed by default:

Table 6.2.1 (a) Execution time percentages of multiple PMCs

The number of PMC path	PMC path of the 1st order of execution	PMC path of the 2nd order of execution	PMC path of the 3rd order of execution	PMC path of the 4th order of execution	PMC path of the 5th order of execution
1 path	100%				
2 paths	85%	15%			
3 paths	75%	15%	10%		
4 paths	70%	10%	10%	10%	
5 paths	60%	10%	10%	10%	10%

An example of changing the execution order and execution time percentages by setting CNC parameters is explained below. In the Figs. 6.2.1 (c) and 6.2.1 (d), sequence programs are executed in the order from the third PMC to the first PMC to the second PMC with the execution time percentage of the third PMC set to 30%, the percentage of the first PMC to 50%, and the percentage of the second PMC to 20%:

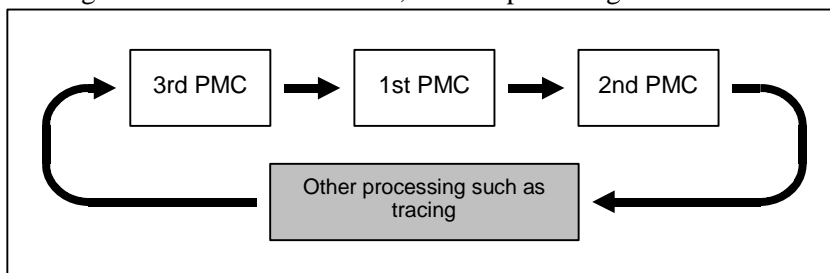

Fig. 6.2.1 (b) Example of setting execution order of multiple PMCs

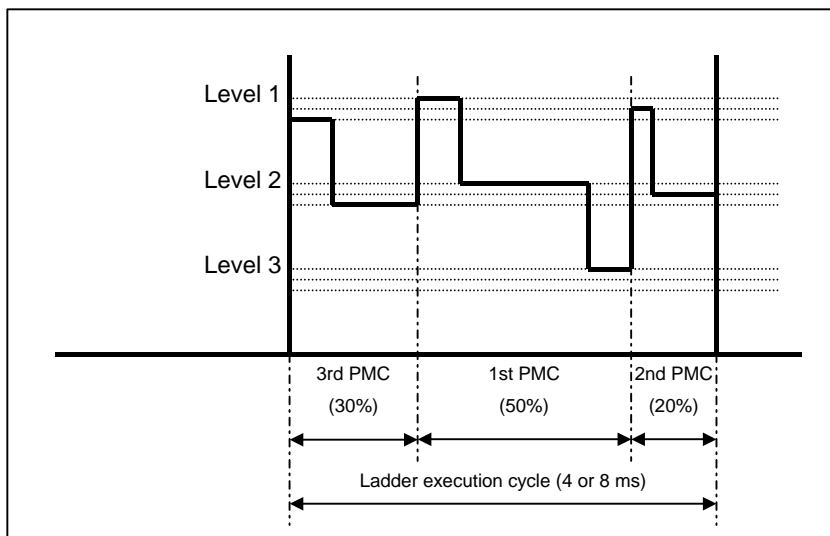

Fig. 6.2.1 (c) Example of setting execution time percentages of multiple PMCs

For details of parameter setting, see PMC PROGRAMMING MANUAL (B-64513EN).

## 6.2.2 Setting I/O Address for I/O Link *i* and I/O Link

The I/O addresses of I/O Link *i* can be set on the I/O configuration edit screen of the PMC. For details of the I/O configuration display/editing screen, see PMC PROGRAMMING MANUAL (B-64513EN).

The I/O addresses of I/O Link channels can be assigned with CNC parameters. If these parameters are not set (0 is set), all channels are assigned to the first PMC by default as Fig. 6.2.2 (a):

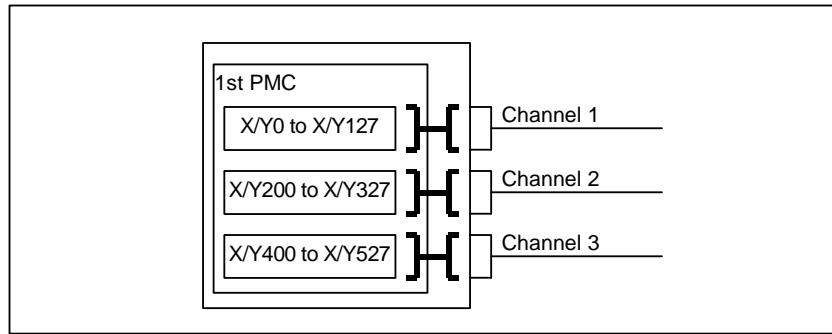

Fig. 6.2.2 (a) Default I/O addresses of I/O Link channels

In the example (Fig. 6.2.2 (b)), channel 1 is assigned to X/Y0 to X/Y127 of the first PMC, channel 2 is assigned to X/Y200 to X/Y327 of the first PMC, channel 3 is assigned to X/Y0 to X/Y127 of the second PMC:

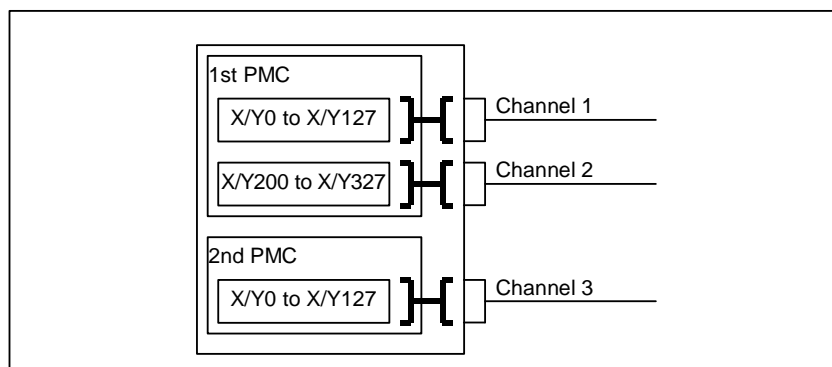

Fig. 6.2.2 (b) Example of I/O address assignment for I/O Link channels

For details of parameter setting, see PMC PROGRAMMING MANUAL (B-64513EN).

### 6.2.3 Interface Between CNC and PMC

The PMC to control the interface between the CNC and PMC and PMC addresses (F/G addresses) can be set with CNC parameters.

With these parameter settings, a desired interface control system can be built, in which the entire CNC-PMC interface of the CNC may be controlled by a single PMC or the CNC-PMC interface may be controlled by multiple PMCs.

For the CNC-PMC interface, a memory area consisting of 10 blocks, each of which is an addressable, 768-byte DI/DO area, is provided.

When viewed from the ladder program in each PMC, these addresses begin with 0.

If these parameters are not set (0 is set), the initial settings are assumed, where the F/G addresses of the CNC equals the F/G addresses of the first PMC as Fig. 6.2.3 (a):

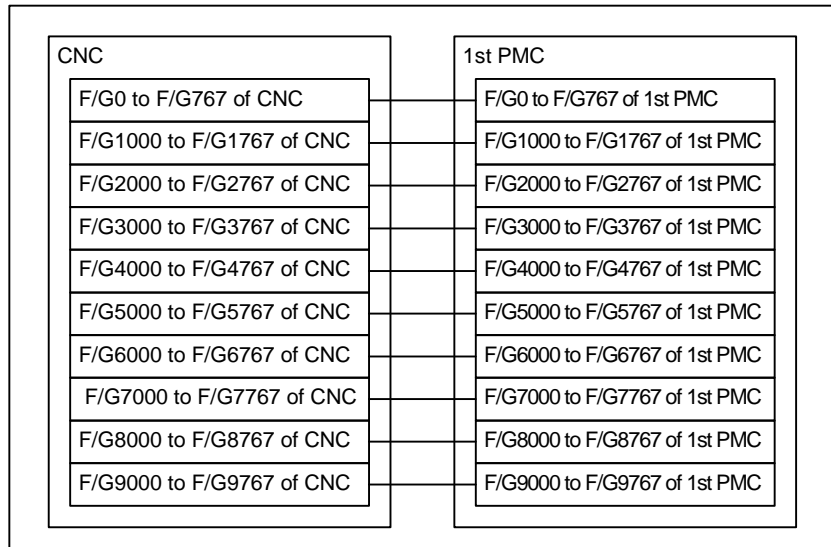

Fig. 6.2.3 (a) Initial settings for CNC-PMC interface

In the example (Fig. 6.2.3 (b)), F/G0 to F/G767 and F/G1000 to F/G1767 of the CNC are assigned to F/G0 to F/G767 and F/G1000 to F/G1767 of the first PMC, and F/G2000 to F/G2767 of the CNC are assigned to F/G0 to F/G767 of the second PMC:

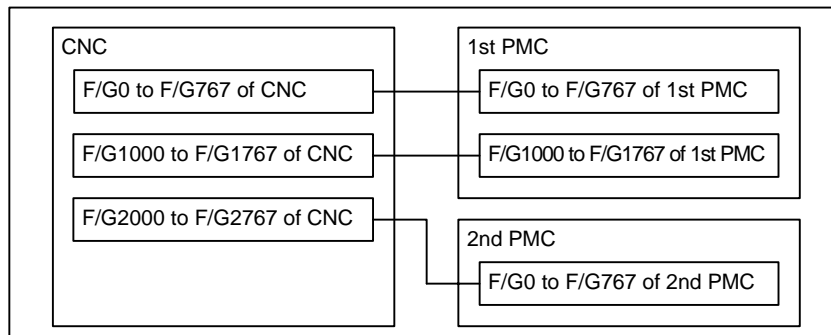

Fig. 6.2.3 (b) Setting example for CNC-PMC interface

## 6.2.4 Multi-Path PMC Interface

The multi-path PMC interface is the communication means between two PMC paths.

Generally, Each path of multi-path PMC system has individual PMC memory space except E address. And, E address can be used to share data of multi-path PMC system. However, this method has a risk that the memory is over written by other PMC path inappropriately.

When using this function, the input and output signals of each path become definitely. So, you can send or receive the data on between two PMC paths safely.

When you output data to N address at one of PMC paths, it can be referenced by M address in other PMC path.

### NOTE

This interface does not support the fourth or fifth PMC path.

Ex.) When using this function with 1st PMC and 2nd PMC :

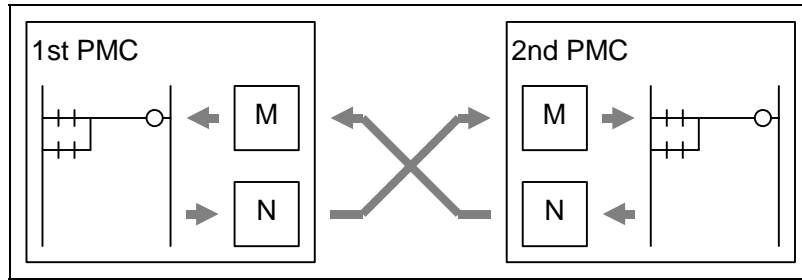

Moreover, signals of M address are synchronized during 1 scan of 2nd level program. Therefore, you can reference the same signal status on the first step and the last step of level2 program, like as X and F address.

### 6.2.5 System Relay Addresses (R9000, Z0)

The System Relay is used to control a sequence program by PMC System software. And, some addresses such as 'Operation results of functional instructions' are used to condition of a sequence program.

The System Relay uses the following PMC address by each PMC Memory Type.

Table 6.2.5 (a) Address of System Relay

	1st to 5th PMC				DCS PMC
	PMC memory A	PMC memory B	PMC memory C	PMC memory D	
System Relay	R9000 ~ R9499	R9000 ~ R9499	Z0 ~ Z499	Z0 ~ Z499	R9000 ~ R9499

**NOTE**

Ladder conversion from PMC memory A or B to PMC memory C or D requires converting System Relay addresses.

#### Operation results of functional instructions

This area holds information necessary for individual ladder levels, such as the operation results of functional instructions. This information is saved/restored when the task is switched.

- (1) R9000, Z0 (operation output register for the ADDB, SUBB, MULB, DIVB, and COMPB functional instructions)

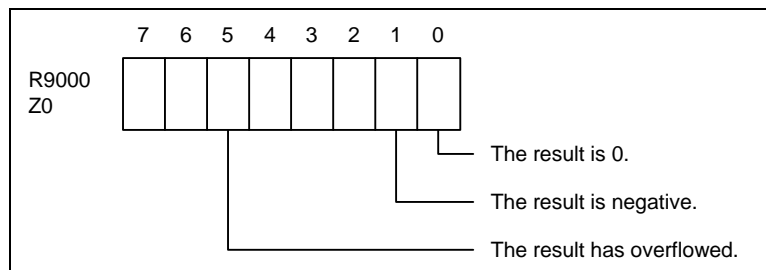

- (2) R9000, Z0 (error output for the EXIN, WINDR, and WINDW functional instructions)

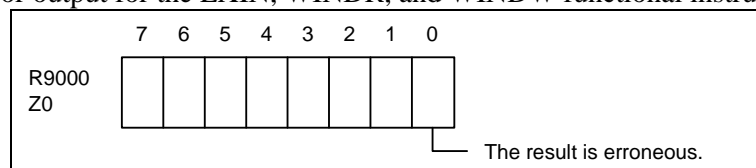

- (3) R9002 to R9005, Z2 to Z5 (operation output registers for the DIVB functional instruction)  
The remainder of a division performed with the DIVB functional instruction is output to these addresses.

**System timers**

Four signals can be used as system timers.  
Their specifications are as follows.

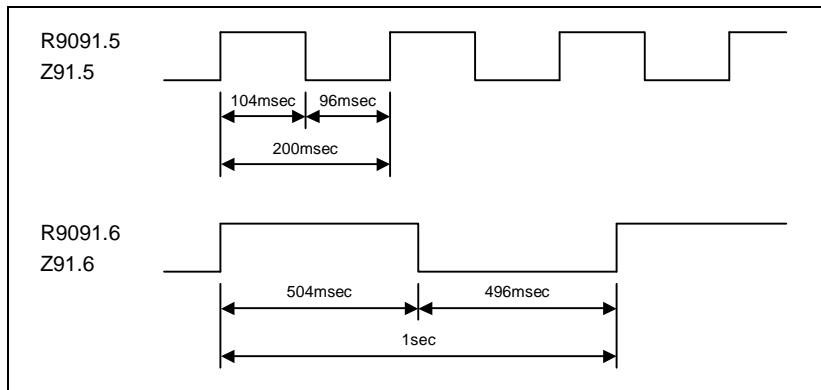
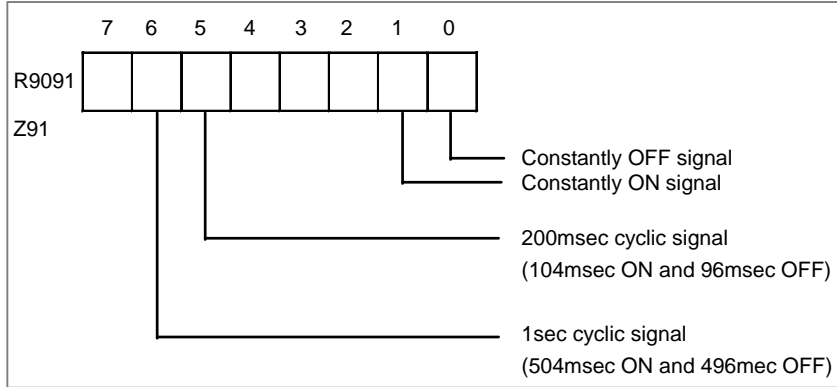

**CAUTION**

- 1 Each signal is initially OFF.
- 2 The signals R9091.0, R9091.1, Z91.0, and Z91.1 are set at the beginning of the first ladder level on every cycle.
- 3 Each pulse signal (ON-OFF signal) has an error of  $\pm 8$  or 4 ms (ladder execution period).

**Ladder execution start signal**

**Ladder stop signal**

**Ladder execution status signal**

Using the ladder execution start and stop signals in a ladder program can detect when the ladder program starts and stops.

Referencing the ladder execution status signal from an external system or program, such as the network board, C Language Executor program, FOCAS1 Ethernet, or HSSB library, can detect the execution status of the ladder program.



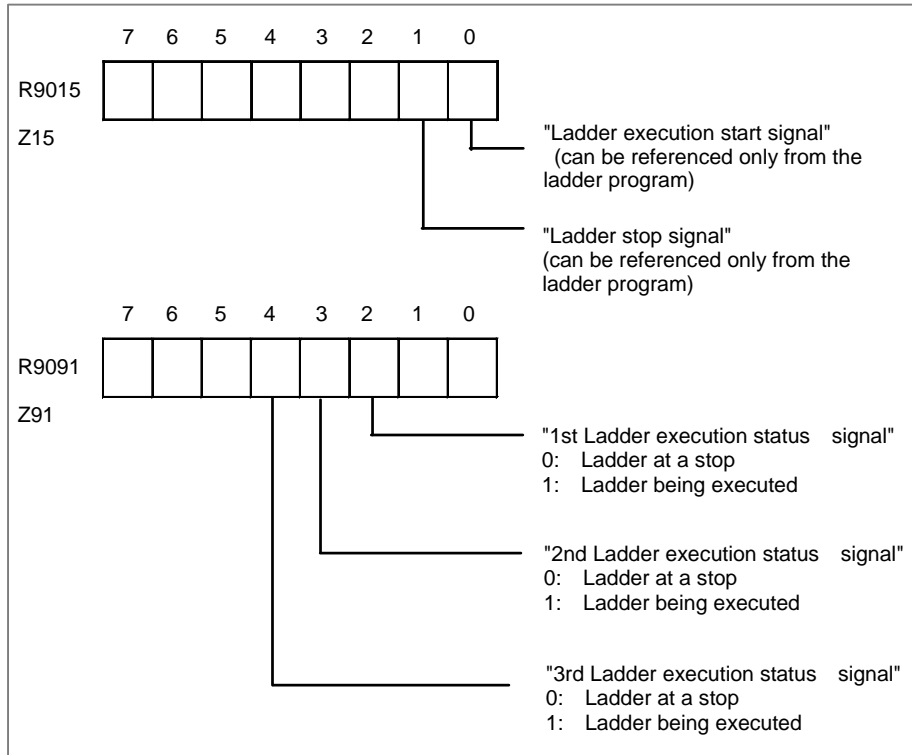

**Signal operation**

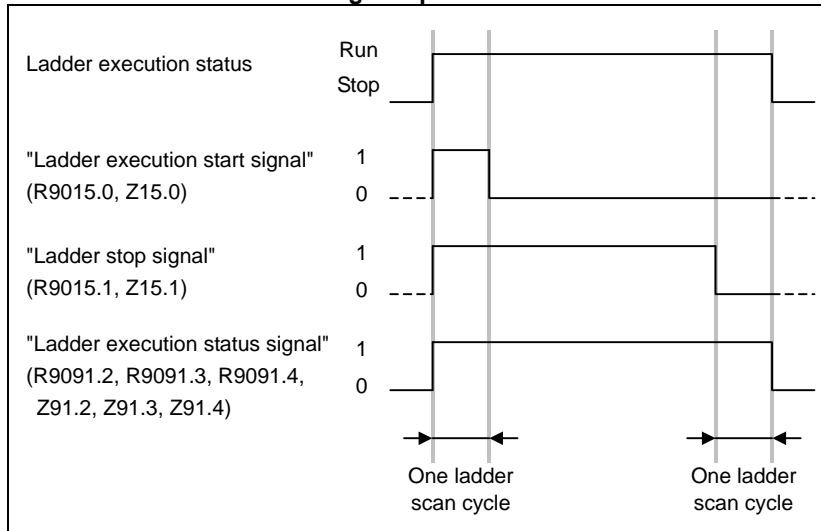

(1) Ladder execution start signal (R9015.0, Z15.0)

When directed to start ladder program execution, the system software starts executing the ladder program, turns on this signal, and keeps it on for the first one scan cycle. Like R9000 or Z0, this signal indicates the status of ladder execution corresponding to each ladder execution level. For this reason, this signal is securely turned on for the first one scan cycle after the start of execution no matter on what execution level the signal is referenced. This signal is turned on when:

- (a) Ladder execution begins at power turn-on.
- (b) The soft key [RUN] on the PMC screen is pressed.
- (c) FANUC LADDER-III or a ladder editing package directs the ladder to start.

Referencing this signal in a ladder program can detect when ladder execution has begun, making it possible to program preprocessing related to ladder execution.

**⚠ CAUTION**  
 Reference this signal only within a ladder program. Do not reference it from an external system or program as it indicates the status of ladder execution separately for each ladder execution level.

(2) Ladder stop signal (R9015.1, Z15.1)

When directed to stop ladder program execution, the system software turns off this signal and keeps it off for the last one scan before stopping ladder program execution. Like R9000 or Z0, this signal indicates the status of ladder execution corresponding to each ladder execution level. For this reason, this signal is securely turned off for the last one scan before the stop of execution no matter on what execution level the signal is referenced. This signal is turned off when:

- (a) The soft key [STOP] on the PMC screen is pressed.
  - (b) FANUC LADDER-III or a ladder editing package directs the ladder to stop.
  - (c) On the PMC DATA I/O screen, the ladder program is loaded to the PMC.
  - (d) FANUC LADDER-III or a ladder editing package stores the ladder program to the PMC.
- Referencing this signal in a ladder program can detect when ladder execution stops, making it possible to program postprocessing related to ladder execution (that is, preprocessing for ladder execution stop). Before the ladder is stopped, for example, it is possible to put signals in an proper state for safety purposes.

**⚠ CAUTION**  
 1 Reference this signal only within the ladder program. Do not reference it from an external system or program as it indicates the status of ladder execution separately for each ladder execution level.  
 2 If the power is turned off or a CNC system alarm occurs, ladder execution and I/O signal transfer are immediately stopped for safety purposes. In this case, therefore, this signal cannot be used.

(3) Ladder execution status signal (R9091.2 to 4, R9093.0 to 1, Z91.2 to 4, Z93.0 to 1)

Referencing this signal from an external system or program, such as the network board, C Language Executor program, FOCAS2 Ethernet, or HSSB library, can detect the execution status of the ladder program.

(4) Example of using the signals

(a) Example of calling a subprogram just before the ladder stops

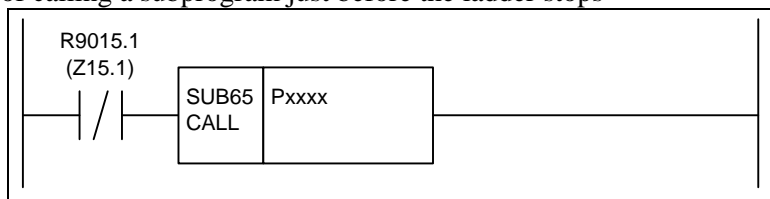

(b) Example of forcibly turning off an output signal programmed on the first ladder level just before the ladder stops

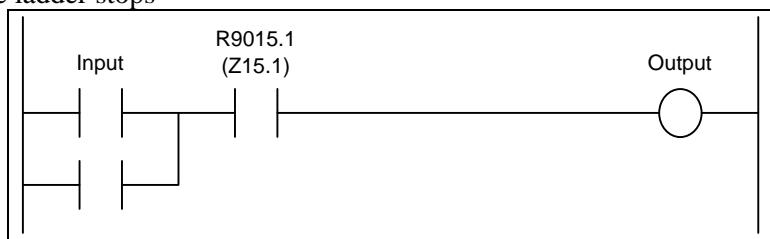

- (c) Example of sending an execution-in-progress signal to the outside  
Outputting the status of this signal as the DO signal (output address from the PMC) assigned to the I/O Link causes the CNC unit to be interlocked with an external system.

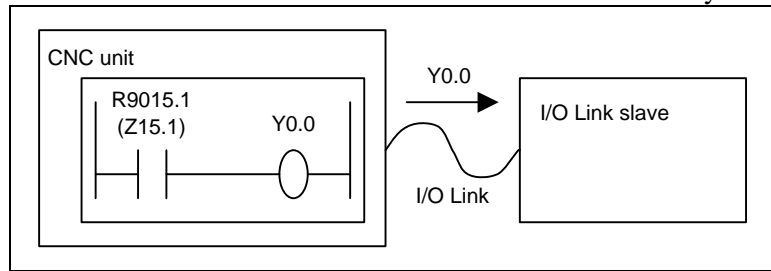

## 6.3 PMC SPECIFICATIONS

### 6.3.1 Basic Specifications

Table 6.3.1 (a) Basic specifications of the PMCs for the Series 30i/31i/32i-A

Function	1st ~ 5th- path PMC	DCS PMC (Note1)
PMC Memory Type(Note2)	1st PMC PMC Memory-B PMC Memory-C PMC Memory-D 2nd~5th PMC PMC Memory-A PMC Memory-B PMC Memory-C Common PMC Memory with 1st PMC	(Note3)
Programming language	Ladder Step sequence(Note4) Function block	Ladder Function block
Number of ladder levels	3	2 (Note5)
Level 1 execution period (Note6)	4 or 8 msec	8 msec
Processing power • Basic instruction processing speed(transition contact) (Note7) • Basic instruction processing speed(Positive/Negative transition contact)	9.1 nsec/step  310 nsec/step	1 μsec/step  19.2 μ sec/step
Program capacity (Note8) • Ladder • Symbol & Comment • Message	Up to about 300,000 steps At least 1KB At least 8KB	Up to about 3,000 steps At least 1KB At least 8KB
Instructions • Basic instructions • Functional instructions (Note9)	24 218 (230)	24 207 (230)
Instructions(When the expanded PMC ladder instruction function is invalid) • Basic instructions • Functional instructions (Note9)	14 93 (105)	14 85 (105)
CNC interface • Inputs (F) • Outputs (G)	768 bytes × 10(Note10) 768 bytes × 10(Note10)	768 bytes 768 bytes
DI/DO • I/O Link (Note 11,12) • I/O Link <i>i</i> (Note 13~16) • Inputs (X) • Outputs (Y)	Up to 4,096 points (Note17) Up to 4,096 points (Note17)	Up to 64 points Up to 64 points
Symbol & Comment (Note18) • Number of symbol characters • Number of comment characters (Note19)	40 255	40 255
Program storage area (Flash ROM) (Note20)	Max. 5MB (total of all sequence programs of PMC paths and PMC message multi-language data)	128KB

**NOTE**

- 1 This PMC is used for Dual Check Safety (DCS) and handles the safety related signals.
- 2 As for the setting the PMC memory type, see PMC Programming Manual (B-64513EN).
- 3 There is no variation of PMC memory type in DCS PMC.
- 4 The Step Sequence is unavailable in 2nd to 5th PMC.
- 5 A program can be created on level 3 to maintain source-level compatibility with programs for other models, but it is not executed.
- 6 CNC parameter is used to specify a level-1 execution period. Note, however, that it is impossible to specify a level-1 execution period for each PMC separately.
- 7 It is the processing speed of contact other than Positive/Negative transition contact.
- 8 The maximum overall program size (including the maximum number of ladder steps, symbols/ comments, and messages) varies depending on option settings. See PMC Programming Manual (B-64513EN) for details.
- 9 For the number of functional instructions, each parenthesized number indicates the number of all functional instructions, and each non-parenthesized number, the number of valid functional instructions.
- 10 It is possible to specify which program is used to control a specific CNC system.
- 11 You can use up to three I/O Link channels (3,072 input points and 3,072 output points).
- 12 The transferred cycle of the signals from I/O Link depends on the combination with each PMC and each I/O Link channel.
- 13 You can use up to two I/O Link *i* channels (4,096 input points and 4,096 output points).
- 14 I/O Link *i* can assign I/O devices for plural PMC paths in the one channel.
- 15 I/O Link *i* can be used for the channel 1 and the channel 2.
- 16 When you use the I/O Link *i*, you can select either the normal mode (2ms) or the high-speed mode (0.5ms) of the transfer cycle of signals for every group unit
- 17 You can use both I/O Link and I/O Link *i* in a CNC system. In the case of the system, you can use up to 4,096 input points and 4096 output points.
- 18 These are the number for extended symbol and comment character. The number of basic symbol character is 16 and the number of comment character is 30.
- 19 This number is the number of single-byte characters. When you use double-byte characters as a comment, the number becomes half.
- 20 The capacity of the program storage area varies depending on option settings. See PMC Programming Manual (B-64513EN) for details.

Table 6.3.1 (b) Basic specifications of each PMC Memory Type

Function	1st to 5th PMC				DCS PMC (Note 1)
	PMC Memory-A	PMC Memory-B	PMC Memory-C	PMC Memory-D	
PMC Memory					
• Internal relay (R)	1,500 bytes	8,000 bytes	16,000 bytes	60,000 bytes	1,500 bytes
• System Relay (R9000 or Z)	500 bytes	500 bytes	500 bytes	500 bytes	500 bytes
• Extra relay (E) (Note2)	10,000 bytes	10,000 bytes	10,000 bytes	10,000 bytes	(Note 3)
• Message display (A) · Display requests · Status displays	2,000 points 2,000 points	2,000 points 2,000 points	4,000 points 4,000 points	6,000 points 6,000 points	(Note 4) (Note 4)
• Nonvolatile memory					
• Timer (T) · Variable timer  · Variable timer precision	80 bytes (40 pieces)  80 bytes (40 pieces)	500 bytes (250 pieces)  500 bytes (250 pieces)	1,000 bytes (500 pieces)  1,000 bytes (500 pieces)	1,000 bytes (500 pieces)  1,000 bytes (500 pieces)	80 bytes (40 pieces)  80 bytes (40 pieces)
• Counter (C) · Variable counter  · Fixed counter	80 bytes (20 pieces)  40 bytes (20 pieces)	400 bytes (100 pieces)  200 bytes (100 pieces)	800 bytes (200 pieces)  400 bytes (200 pieces)	1200 bytes (300 pieces)  600 bytes (300 pieces)	80 bytes (20 pieces)  40 bytes (20 pieces)
• Keep relay (K) · User area · System area	20 bytes 100 bytes	100 bytes 100 bytes	200 bytes 100 bytes	300 bytes 100 bytes	20 bytes 100 bytes
• Data table (D)	3,000 bytes	10,000 bytes	20,000 bytes (Note 5)	60,000 bytes (Note 5)	3,000 bytes
• Step sequence · Step number (S)	(None)	2,000 bytes	2,000 bytes	2,000 bytes	(None)
Functional instructions					
• Variable timers (TMR)	40 pieces	250 pieces	500 pieces	500 pieces	40 pieces
• Fixed timers (TMRB/TMRBF)	100 pieces	500 pieces	1,000 pieces	1,500 pieces	100 pieces
• Variable counters (CTR)	20 pieces	100 pieces	200 pieces	300 pieces	20 pieces
• Fixed counters (CTRB)	20 pieces	100 pieces	200 pieces	300 pieces	20 pieces
• Rising/Falling edge detection (DIFU/DIFD)	256 pieces	1,000 pieces	2,000 pieces	3,000 pieces	256 pieces
• Labels (LBL)	9,999 pieces	9,999 pieces	9,999 pieces	9,999 pieces	9,999 pieces
• Subprograms (SP)	512 pieces	5,000 pieces	5,000 pieces	5,000 pieces	512 pieces

**NOTE**

- 1 This PMC is used for Dual Check Safety function (option).
- 2 The extra relay is common memory for the multi-PMC function. This means that its size covers all of PMCs. Moreover, It is possible to use the extra relay as nonvolatile memory by the option.
- 3 No extra relay is available for DCS PMC.
- 4 The message display relay is ineffective in DCS PMC because the message display function is unavailable in it.
- 5 Under the configuration having two or more paths of PMC Memory-C or one path of PMC Memory-D, please specify the "Nonvolatile PMC data table area expansion 40KB" option. If this option is not added, the expanded data table area (D10000~) is not kept after rebooting CNC. Refer to PMC Programming Manual (B-64513EN) for details.

## 6.3.2 Addresses

Table 6.3.2 (a) PMC Addresses list (1)

Signals	Symbol	1st to 5nd PMC				DCS PMC (Note 1)
		PMC memory A	PMC memory B	PMC memory C	PMC memory D	
Input signal to the PMC from the machine	X	X0~X127 X200~X327 X400~X527 X600~X727	X0~X127 X200~X327 X400~X527 X600~X727	X0~X127 X200~X327 X400~X527 X600~X727	X0~X127 X200~X327 X400~X527 X600~X727	X0~X127
		X1000~X1127 (Note 2)	X1000~X1127 (Note 2)	X1000~X1127 (Note 2)	X1000~X1127 (Note 2)	
Output signal from the PMC to the machine	Y	Y0~Y127 Y200~Y327 Y400~Y527 Y600~Y727	Y0~Y127 Y200~Y327 Y400~Y527 Y600~Y727	Y0~Y127 Y200~Y327 Y400~Y527 Y600~Y727	Y0~Y127 Y200~Y327 Y400~Y527 Y600~Y727	Y0~Y127
		Y1000~Y1127 (Note 2)	Y1000~Y1127 (Note 2)	Y1000~Y1127 (Note 2)	Y1000~Y1127 (Note 2)	
Input signal to the PMC from the CNC	F	F0~F767 F1000~F1767 F2000~F2767 F3000~F3767 F4000~F4767 F5000~F5767 F6000~F6767 F7000~F7767 F8000~F8767 F9000~F9767	F0~F767 F1000~F1767 F2000~F2767 F3000~F3767 F4000~F4767 F5000~F5767 F6000~F6767 F7000~F7767 F8000~F8767 F9000~F9767	F0~F767 F1000~F1767 F2000~F2767 F3000~F3767 F4000~F4767 F5000~F5767 F6000~F6767 F7000~F7767 F8000~F8767 F9000~F9767	F0~F767 F1000~F1767 F2000~F2767 F3000~F3767 F4000~F4767 F5000~F5767 F6000~F6767 F7000~F7767 F8000~F8767 F9000~F9767	F0~F767
		G0~G767 G1000~G1767 G2000~G2767 G3000~G3767 G4000~G4767 G5000~G5767 G6000~G6767 G7000~G7767 G8000~G8767 G9000~G9767	G0~G767 G1000~G1767 G2000~G2767 G3000~G3767 G4000~G4767 G5000~G5767 G6000~G6767 G7000~G7767 G8000~G8767 G9000~G9767	G0~G767 G1000~G1767 G2000~G2767 G3000~G3767 G4000~G4767 G5000~G5767 G6000~G6767 G7000~G7767 G8000~G8767 G9000~G9767	G0~G767 G1000~G1767 G2000~G2767 G3000~G3767 G4000~G4767 G5000~G5767 G6000~G6767 G7000~G7767 G8000~G8767 G9000~G9767	
Input signal from other PMC path	M	M0~M767	M0~M767	M0~M767	M0~M767	
Output signal to other PMC path	N	N0~N767	N0~N767	N0~N767	N0~N767	



Table 7.3.2(b) PMC Addresses list (2)

Signals	Symbol	1st~5nd PMC				DCS PMC (Note 1)
		PMC memory A	PMC memory B	PMC memory C	PMC memory D	
Internal relay	R	R0~R1499	R0~R7999	R0~R15999	R0~R59999	R0~R1499
System relay	R / Z	R9000~R9499	R9000~R9499	Z0~Z499	Z0~Z499	R9000~R9499
Extra relay	E	E0~E9999 (Note 3)	E0~E9999 (Note 3)	0~E9999 (Note 3)	E0~E9999 (Note 3)	(Note 4)
Message display · Display request · Display status	A	A0~A249 A9000~A9249	A0~A249 A9000~A9249	A0~A499 A9000~A9499	A0~A749 A9000~A9749	A0~A249 A9000~A9249
Timer · Variable timer · Variable timer precision (Note 5)	T	T0~T79 T9000~T9079	T0~T499 T9000~T9499	T0~T999 T9000~T9999	T0~T999 T9000~T9999	T0~T79 T9000~T9079
Counter · Variable counter · Fixed counter	C	C0~C79 C5000~C5039	C0~C399 C5000~C5199	C0~C799 C5000~C5399	C0~C1199 C5000~C5599	C0~C79 C5000~C5039
Keep relay · User area · System area	K	K0~K19 K900~K999	K0~K99 K900~K999	K0~K199 K900~K999	K0~K299 K900~K999	K0~K19 K900~K999
Data table	D	D0~D2999	D0~D9999	D0~D19999 (Note 6)	D0~D59999 (Note 6)	D0~D2999
Label	L	L1~L9999	L1~L9999	L1~L9999	L1~L9999	L1~L9999
Subprogram	P	P1~P512	P1~P5000	P1~P5000	P1~P5000	P1~P512
Step number (Step sequence)	S	(なし)	S1~S2000	S1~S2000	S1~S2000	(なし)

**NOTE**

- 1 This PMC is used for Dual Check Safety function (option).
- 2 This area is reserved for PMC management software. Do not use it in user programs.
- 3 This area is common memory for the multi-path PMC function. Each program can write and read the same value in the area.
- 4 No extra relay is available for the Dual Check Safety PMC.
- 5 This area is used to specify the precision of a variable timer.
  - Don't modify the value of active timer and its precision except for writing same value.
  - Don't set the value other than the following range.
  - If above rules are violated, the behavior of the timer is not guaranteed.

The value of precision

  - 0: Default (8msec or 4msec)
  - 1: 1msec
  - 2: 10msec
  - 3: 100msec
  - 4: 1sec
  - 5: 1min
- 6 To save all area of the data table, the "Nonvolatile PMC data table area expansion (40KB)" option may be necessary. See PMC Programming Manual (B-64513EN) for details.

## 6.4 OPERATING THE PMC SCREEN

The basic configuration of the PMC screen is described below.

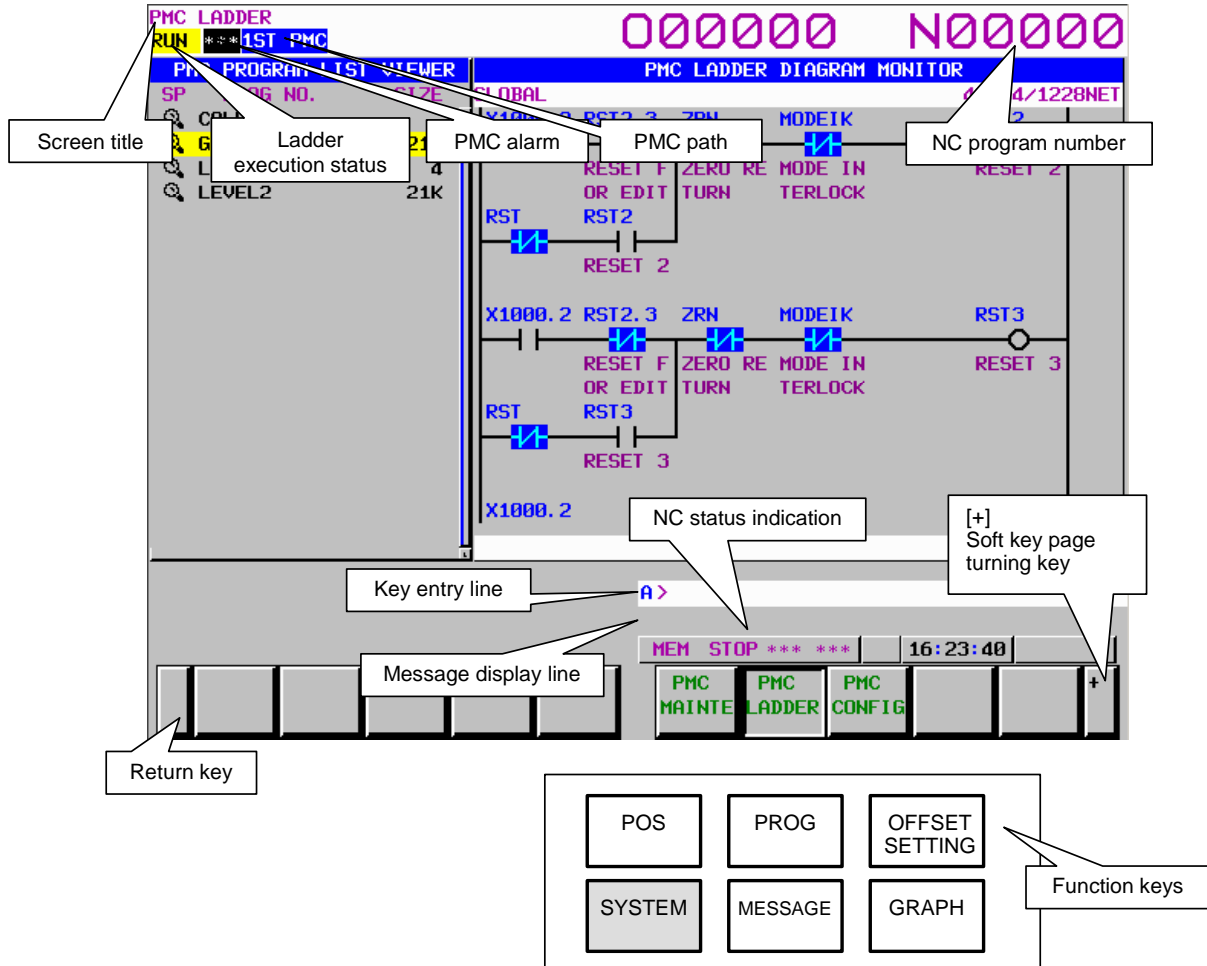

- Screen title: Displays the name of a specific submenu of the PMC.
- Ladder execution status: Displays the execution status of the ladder program.
- PMC alarm: Indicates whether any PMC alarm is occurring.
- PMC path: Displays the currently selected PMC.
- NC program number: Displays the number of the currently selected NC program.
- Key entry line: Line for entering a numerical value or character key string.
- Message display line: Displays an error or warning message.
- NC status indication: Displays the NC mode, the execution status of the NC program, the currently selected NC path number.
- Return key: Used to switch from the PMC operation menu to a specific PMC submenu or from a specific PMC submenu to the main menu of the PMC.
- Soft key page turning key: Used to turn soft key pages.

### About the PMC screen

When you click the "SYSTEM" function key and then turn the soft key page by clicking the soft key [+], the main menu of the PMC is displayed.

The PMC main menu offers the following three types of submenus, which are respectively used for specific purposes.

- PMC maintenance

- PMC ladder
- PMC configuration

Each of these PMC submenus is explained below.

(1) PMC maintenance menu

This menu displays the screens related to the maintenance of the PMC, such as those for PMC signal status monitoring and traces and for PMC data display and editing.

(2) PMC ladder menu

This menu displays the screens related to the display and editing of the ladder program.

(3) PMC configuration menu

This menu displays the screens related to the display and editing of the data other than the ladder constituting the sequence program, as well as the screen for setting the PMC functions.

This manual briefly describes the screen of each of the PMC maintenance and PMC ladder menus. For detailed descriptions and the PMC configuration menu, refer to "PMC Programming Manual (B-64513EN)."

### 6.4.1 Transition of the PMC Screens

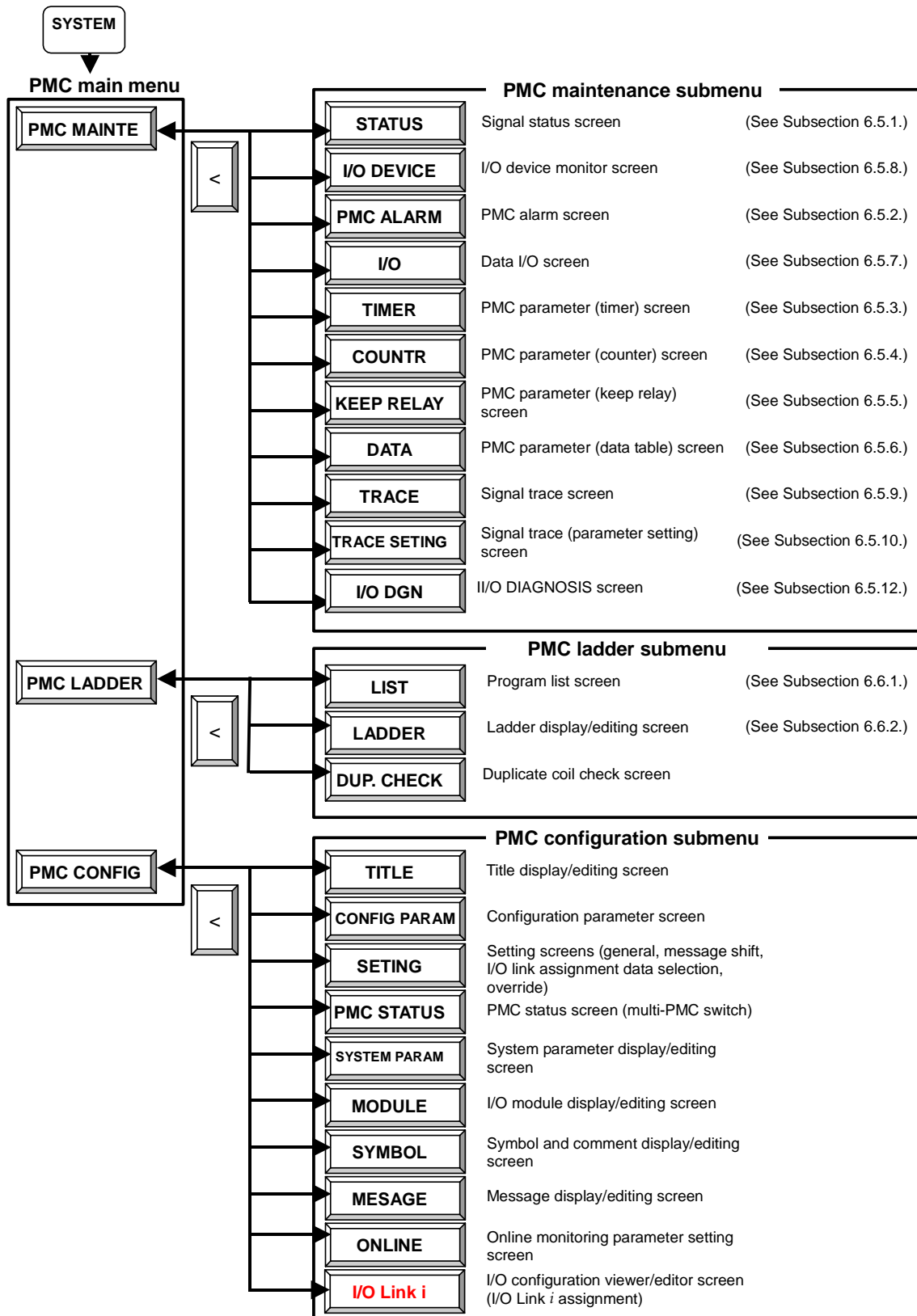

## 6.5 PMC DIAGNOSIS AND MAINTENANCE SCREENS ([PMC MAINT])

### 6.5.1 Monitoring PMC Signal Status ([STATUS] Screen)

The SIGNAL STATUS screen displays the data at all addresses specified in the program. The data of each address consists of a bit pattern (0s and/or 1s) and a hexadecimal or decimal number at the rightmost position on a byte-by-byte basis.

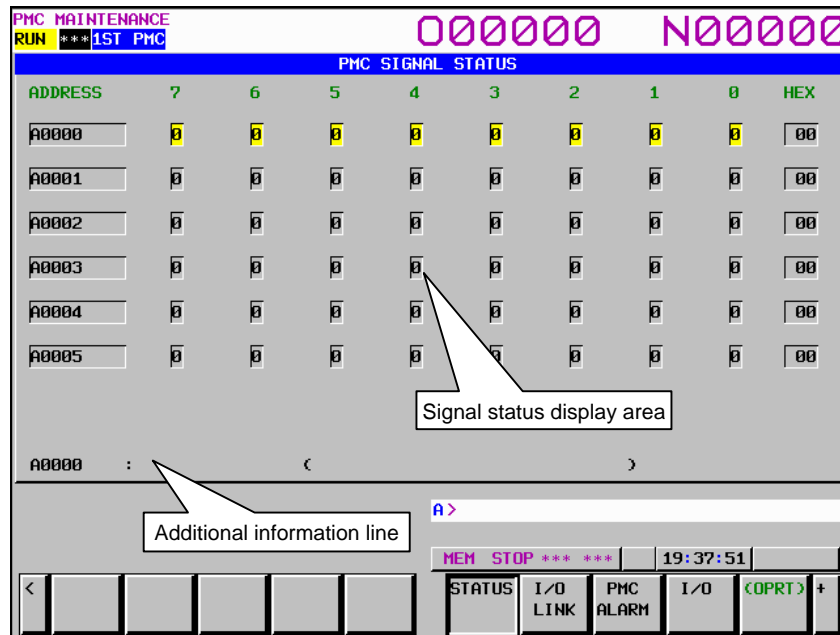
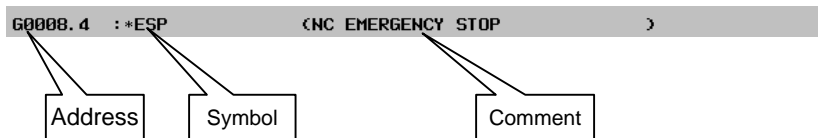

Fig. 6.5.1 (a) Signal status screen

The additional information line at the bottom of the screen displays the symbol and comment of the address on which the cursor is placed. When the cursor is placed on a byte, the byte symbol and comment are displayed.



#### Table contents

- ADDRESS: Address referenced by a sequence program
- 0 to 7: Data at each bit position
- HEX: Display of each byte in hexadecimal
- DEC: Display of each byte in decimal

#### Operation procedure

- (1) Press the soft key [STATUS]. The screen shown above appears.
- (2) Key in an address whose data to be displayed, then press the soft key [SEARCH].
- (3) The data starting at the input address is displayed as a bit pattern.
- (4) To display the data at another address, press the cursor keys, page keys, or soft key [SEARCH].
- (5) To modify the status of a signal, switch to the forced I/O screen by pressing the soft key [FORCE].

**NOTE**  
 The soft key [FORCE] is displayed and usable when the forced I/O function is enabled. For details, see PMC PROGRAMMING MANUAL (B-64513EN).

- (6) On the forced I/O screen, an overridden X signal or Y signal is prefixed by a greater-than sign (>) to indicate the setting of override.

ADDRESS	7	6	5	4	3	2	1	0	HEX
X0000	0	>1	0	1	>0	0	>0	0	50

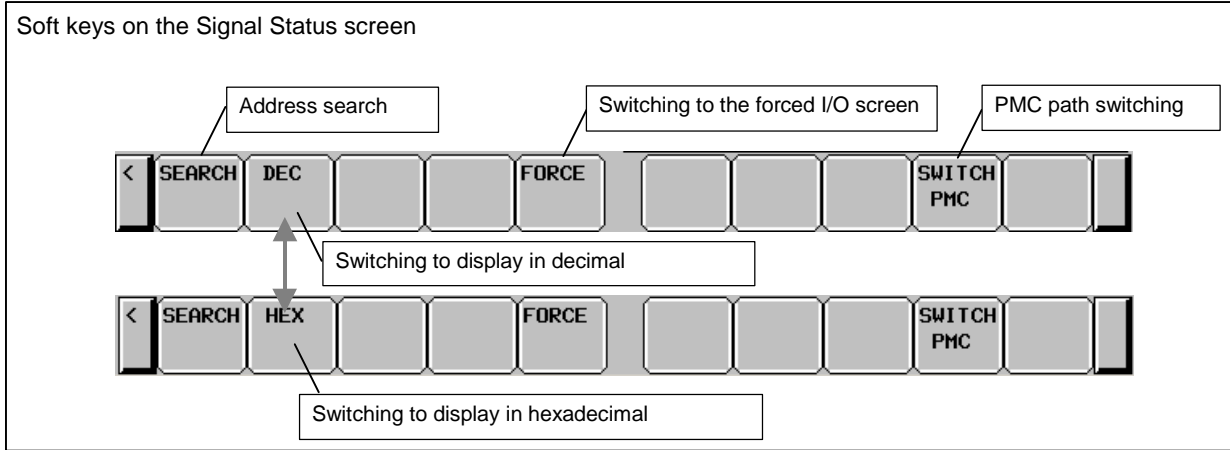

Fig. 6.5.1 (b) Soft keys on the SIGNAL STATUS screen

## 6.5.2 Checking PMC Alarms ([PMC ALARM] Screen)

On this screen, an alarm message output from the PMC is displayed. To move to the PMC alarm screen, press the soft key [PMC ALARM].

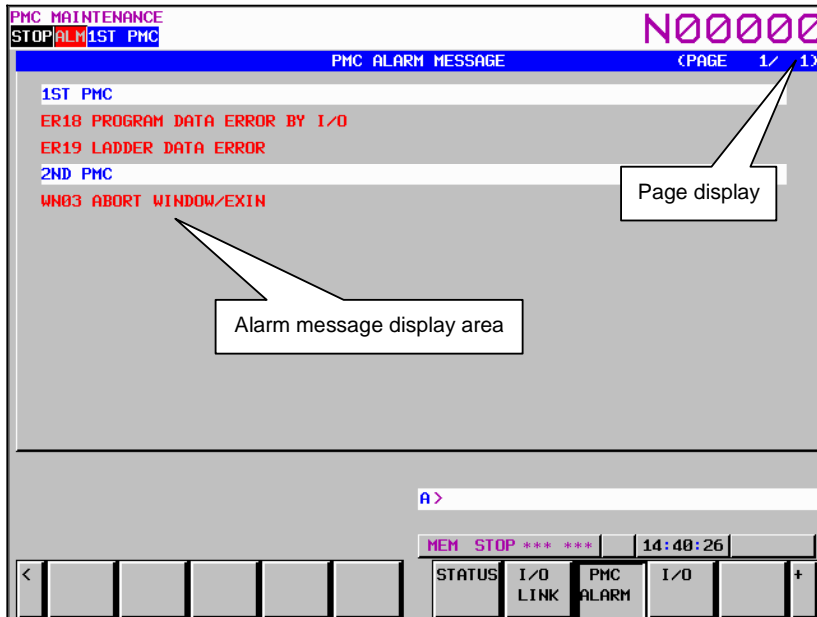

Fig. 6.5.2 (a) PMC alarm screen

In the alarm message display area, an alarm message output from the PMC is displayed. When many alarm messages are output to two or more pages, the page keys can be used to switch from one page to another.

In the page display area to the right of the title, the number of the page currently displaying messages is indicated.

For information about messages displayed, see Appendix A “Alarm List.”

### 6.5.3 Setting and Displaying Variable Timers ([TIMER] Screen)

This screen is used to set and display timer values for functional instruction variable timers (TMR:SUB 3). This screen can be used in one of two modes: the simple display mode and the comment display mode. To move to the TIMER screen, press the soft key [TIMER].

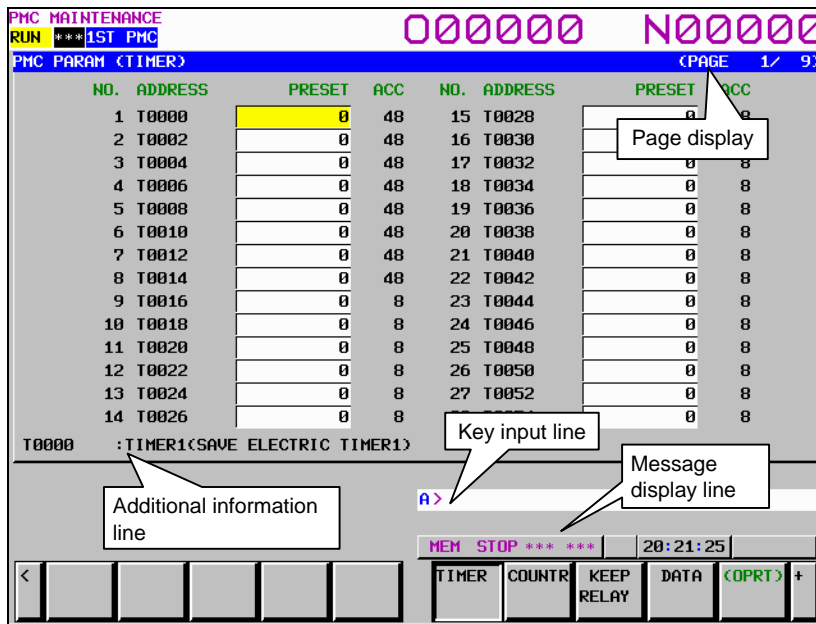

Fig. 6.5.3 (a) Time screen: simple display mode

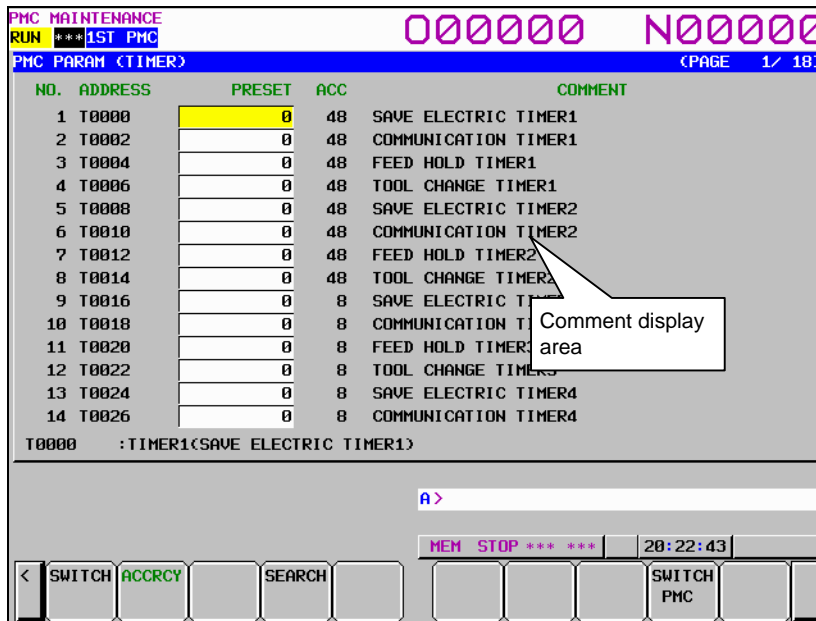

Fig. 6.5.3 (b) Time screen: comment display mode

#### Table contents

- NO.: Timer number specified for a functional instruction timer.
- ADDRESS: Address referenced by a sequence program

- PRESET: Timer setting value
- ACC: Timer accuracy
- COMMENT: T address comment

In the PRESET column, timer setting values are displayed. When the timer accuracy is 8, 48, 1, 10, or 100 ms, only a numeric value is displayed. When the timer accuracy is the second or minute, a time value is displayed using H, M, and S with the separator "\_" used to delimit one unit from another as follows:

aaH\_bbM\_ccS

In the ACC column, timer accuracy values are displayed. The table below indicates the time setting values and notation of each accuracy value.

Timer No. (Note)	Accuracy notation	Minimum time setting	Maximum time setting
1 to 8	48 (initial value)	48 ms	1572.8 seconds
9 to 250	8 (initial value)	8 ms	262.1 seconds
1 to 250	1	1 ms	32.7 seconds
1 to 250	10	10 ms	327.7 seconds
1 to 250	100	100 ms	54.6 minutes
1 to 250	S	1 second	546 minutes
1 to 250	M	1 minute	546 hours

**NOTE**

Above table is for PMC Memory-B. the timer number is 1 to 40 in PMC Memory-A and DCSPMC, and 1 to 500 in PMC Memory-C/D.

The additional information line at the bottom of the screen displays the symbol and comment of the address on which the cursor is placed.

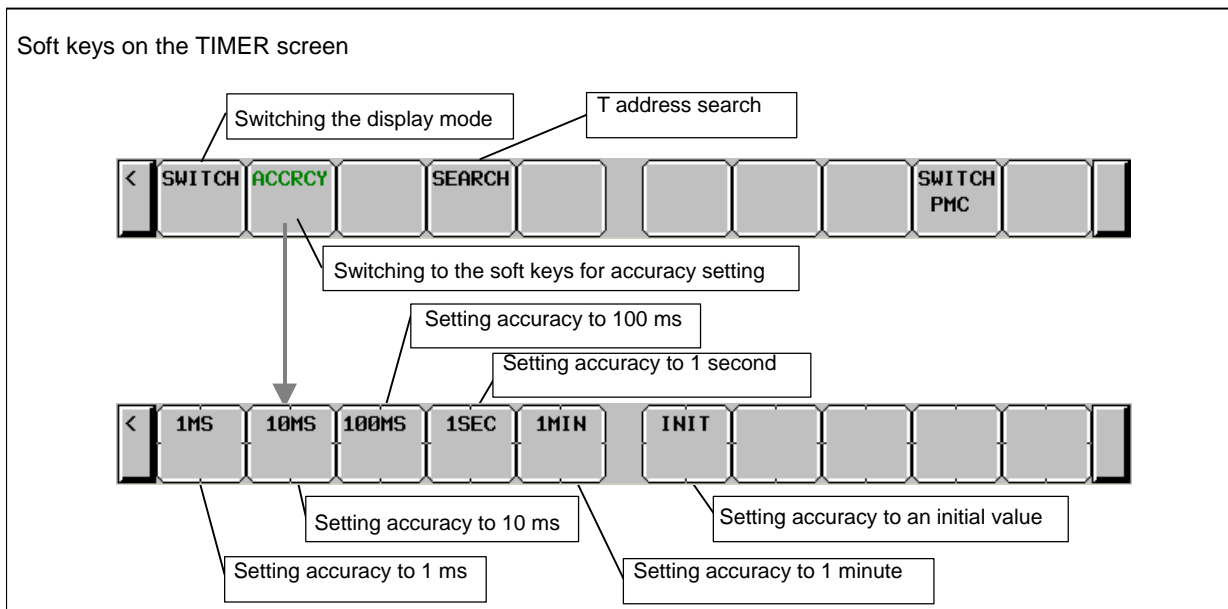



## 6.5.4 Setting and Displaying Counter Values ([COUNTR] Screen)

This screen is used to set and display the maximum and current counter values for functional instruction counters (CTR: SUB 5). This screen can be used in one of two modes: the simple display mode and the comment display mode. To move to the COUNTER screen, press the soft key [COUNTR].

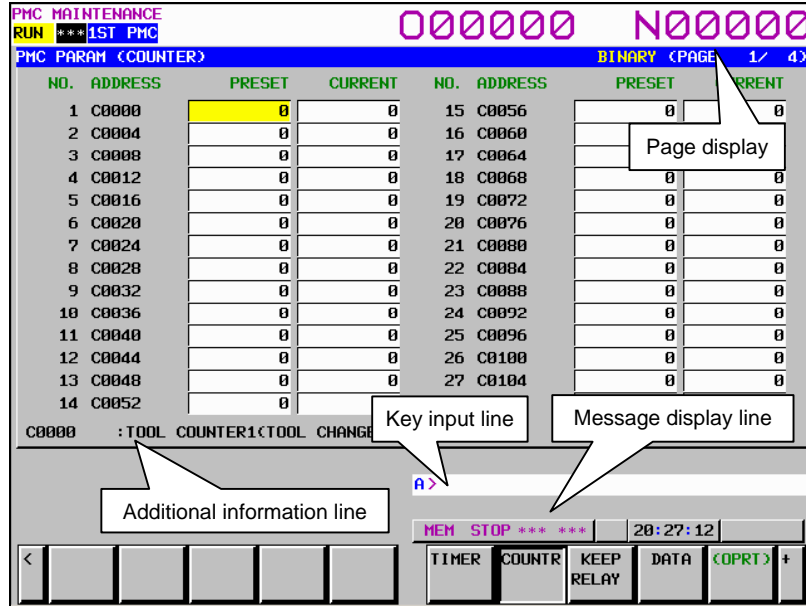

Fig. 6.5.4 (a) Counter screen: simple display mode

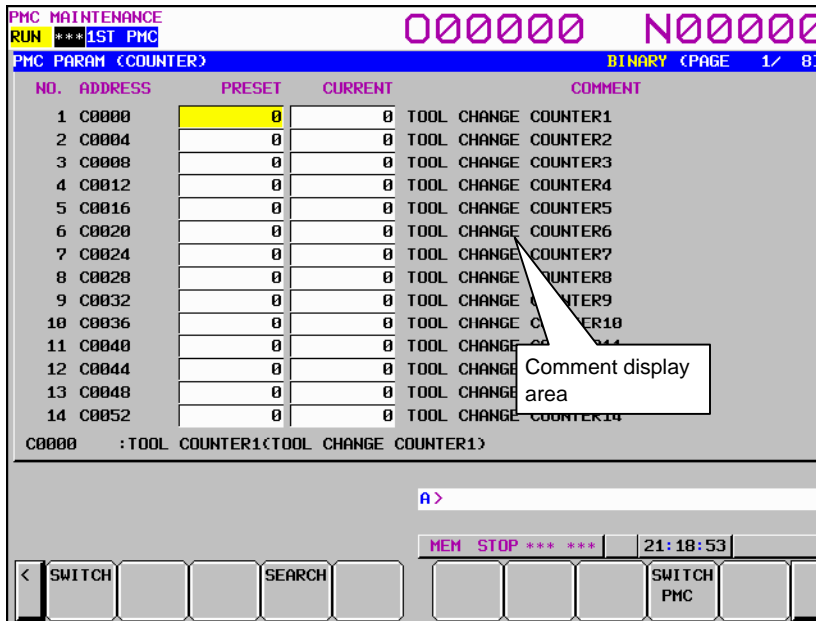

Fig. 6.5.4 (b) Counter screen: comment display mode

### Table contents

- NO.: Counter number specified for a functional instruction counter
- ADDRESS: Address referenced by a sequence program
- PRESET: Maximum counter value (a minimum counter value is specified by a counter instruction)
- CURRENT: Current counter value
- COMMENT: Comment on the C address of a setting value

The additional information line at the bottom of the screen displays the symbol and comment of the address on which the cursor is placed. If the cursor is placed on a PRESET value, the symbol and comment of the address of the PRESET value are displayed. If the cursor is placed on a CURRENT value, the symbol and comment of the address of the CURRENT value are displayed.

Counter types and maximum values

Counter type	PRESET maximum value	CURRENT maximum value
BINARY	32767	32767
BCD	9999	9999

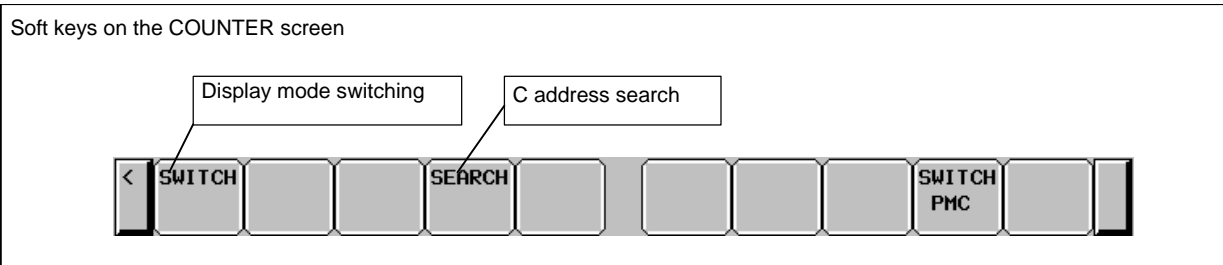

### 6.5.5 Setting and Displaying Keep Relays ([KEEP RELAY] Screen)

This screen is used for setting and displaying the Keep Relays. To move to the KEEP RELAY screen, press the [KEEP RELAY] soft key.

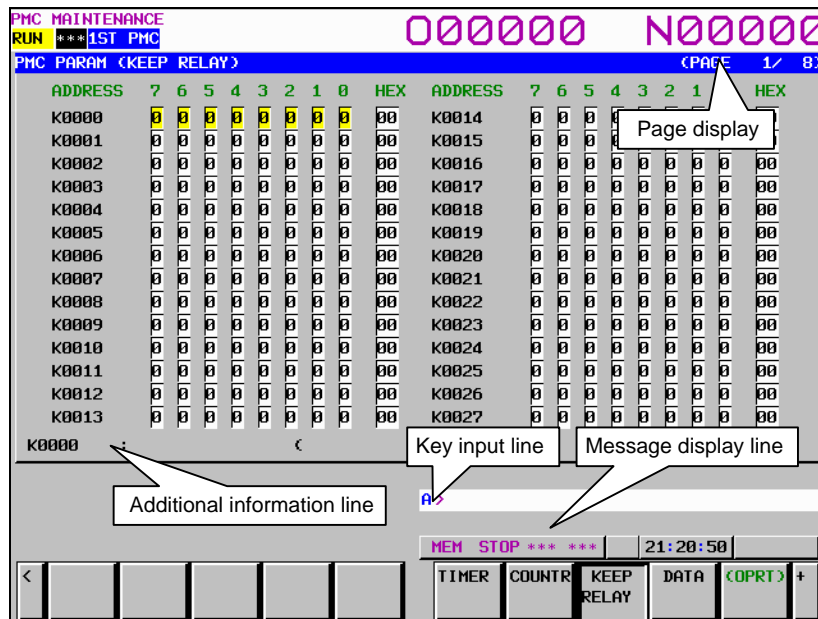

Fig. 6.5.5 (a) Keep relay screen

#### Contents of the table

- ADDRESS: Address referred by sequence Program
- 0 to 7: Contents of each bit
- HEX: Value of the byte data in hexadecimal notation

The additional information line at the bottom of the screen displays the symbol and comment of the address on which the cursor is placed. When the cursor is placed on a byte, the byte symbol and comment are displayed.

Since Keep Relay is nonvolatile memory, the contents are not lost even if you turn off the power. The Keep Relay area consists of parts as follows.

	30i/31i/32i-B				
	PMC memory Type A	PMC memory Type B	PMC memory Type C	PMC memory Type D	Dual check safety PMC (option)
User area	K0~K19	K0~K99	K0~K199	K0~K299	K0~K19
Area for management software	K900~K999	K900~K999	K900~K999	K900~K999	K900~K999

**CAUTION**  
 If the area for the PMC management software is protected by the programmer protection function, the area is not displayed on the KEEP RELAY screen. For details, see PMC PROGRAMMING MANUAL (B-64513EN).

### 6.5.6 Setting and Displaying Data Tables ([DATA] Screen)

There are two data table types (data table control data table and data table). To move to the data screen, press the soft key [DATA].

(1) DATA TABLE CONTROL screen ([LIST] screen)

Pressing the soft key [DATA] displays the DATA TABLE CONTROL screen for data table management. This screen can be used in one of two modes: the simple display mode and the comment display mode.

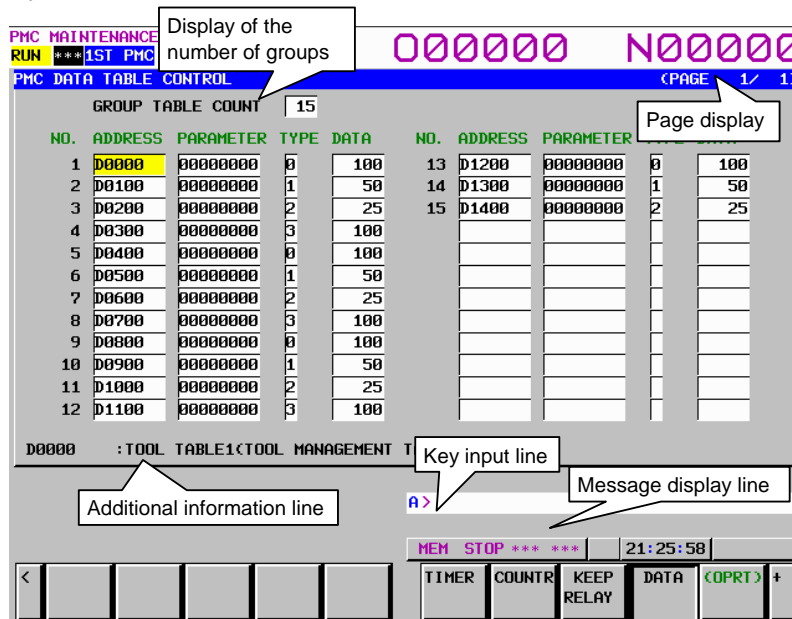

Fig. 6.5.6 (a) Data table control data screen: simple display mode

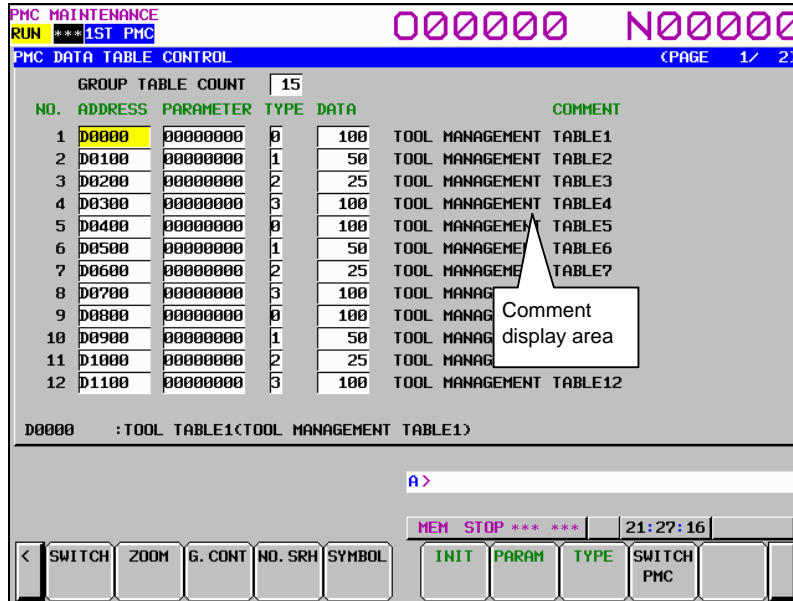

Fig. 6.5.6 (b) Data table control data screen: comment display mode

**Table contents**

- GROUP TABLE COUNT: Number of data items in the data table
- NO.: Group number
- ADDRESS: Data table start address
- PARAMETER: Data table control parameter
- TYPE: Data length (0 = 1 byte, 1 = 2 bytes, 2 = 4 bytes, 3 = bit)
- DATA: Number of data items in each data table
- COMMENT: Comment on the start D address of each group

The additional information line at the bottom of the screen displays the symbol and comment of the address on which the cursor is placed. When the cursor is placed on the PARAMETER, TYPE, or DATA column, the current setting is displayed.

The ADDRESS column displays the start address of a data table. Multiple groups may share an address. When the soft key [SYMBOL] is pressed, the symbol of the start address is displayed.

**NOTE**  
The data table control parameters have the following meanings:

#7	#6	#5	#4	#3	#2	#1	#0

- 0: Binary format
- 1: BCD format (Bits 2 and 3 are invalid.)
- 0: Without input protection
- 1: With input protection
- 0: Binary or BCD format (Bit 0 is valid.)
- 1: Hexadecimal format (Bits 0 and 3 are invalid.)
- 0: Signed (valid only when bits 0 and 2 are set to 0)
- 1: Unsigned (valid only when bits 0 and 2 are set to 0)

**NOTE**

- 1 When data table control data is protected by the programmer protection function, the data table control data screen is not displayed. For details, see PMC PROGRAMMING MANUAL (B-64513EN).
- 2 When PMC parameters are output using the I/O screen (see Subsection 7.5.7, "Data Input/Output ([I/O] Screen)"), only the data of an address D area set in the data table control data is output from the data table screen. The data of an address D area not set in the data table control data is not output.

Soft keys on the DATA TABLE CONTROL screen

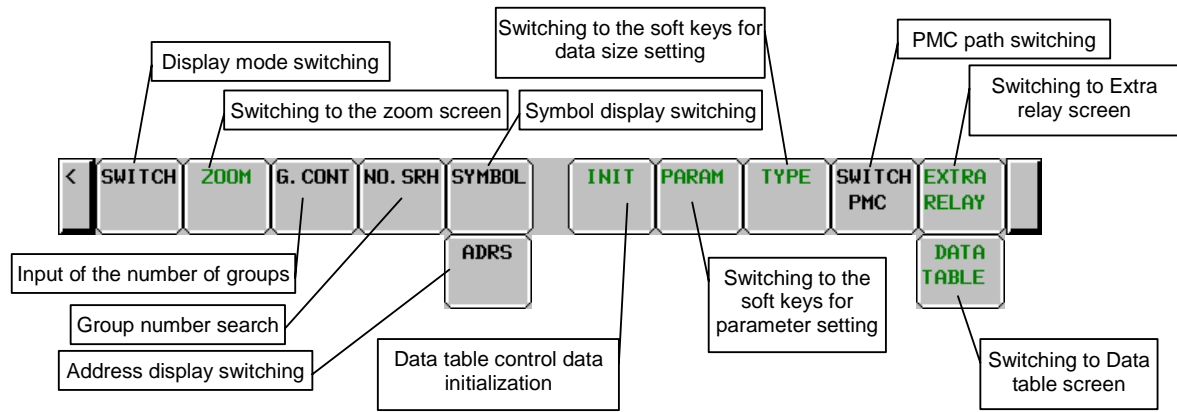

Soft keys for parameter setting

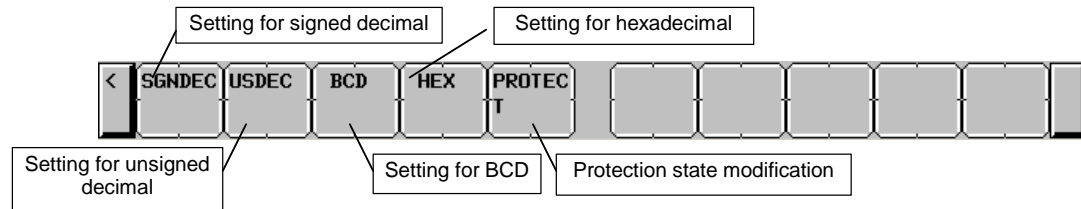

Soft keys for data size setting

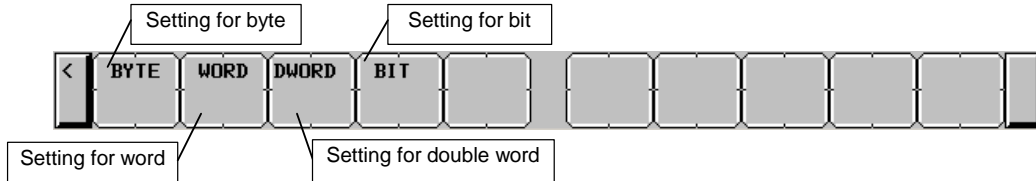

(2) DATA TABLE screen ([ZOOM] screen)

If the data table control data is specified, clicking the soft key [ZOOM] on the data table control data screen displays the data table setting screen. This screen can be used in one of three modes: the simple display mode, the comment display mode, and the bit display mode.

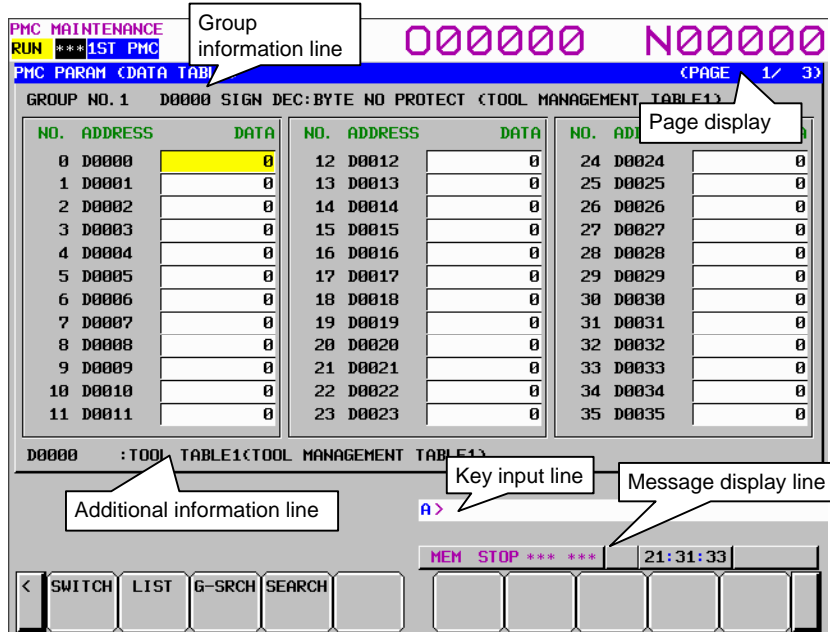

Fig. 6.5.6 (c) Data table screen: simple display mode

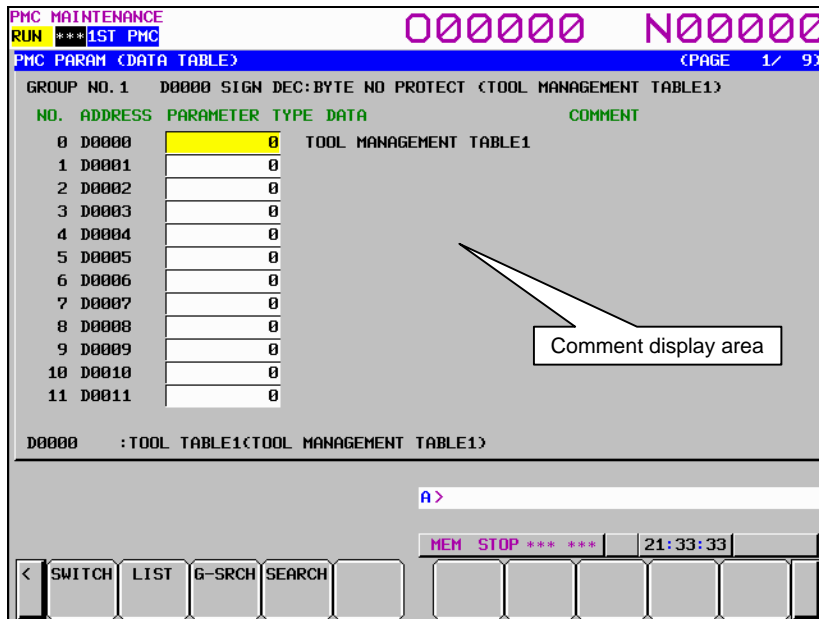

Fig. 6.5.6 (d) Data table screen: comment display mode

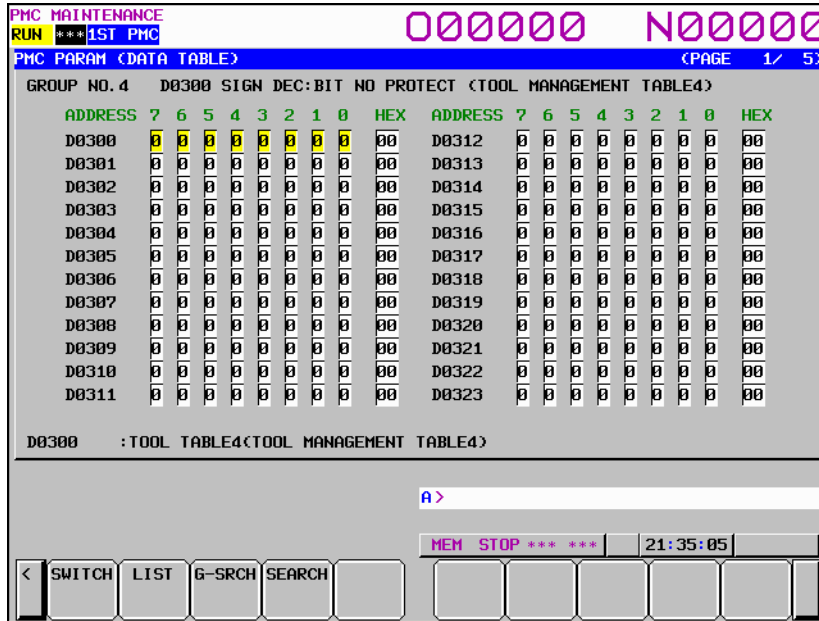

Fig. 6.5.6 (e) Data table screen: bit display mode

**Table contents**

- ADDRESS: Address used by the sequence program
- DATA: Data value of data table
- COMMENT: Comment on the D address
- 0 to 7: Data of each bit
- HEX: Display of each byte in hexadecimal

The group information line at the top of the screen displays a group number, group start address, settings, and comment on the start address.

The additional information line at the bottom of the screen displays the symbol and comment of the address on which the cursor is placed. In the bit display mode, a bit symbol and comment, or a byte symbol and comment are displayed, depending on the cursor position.

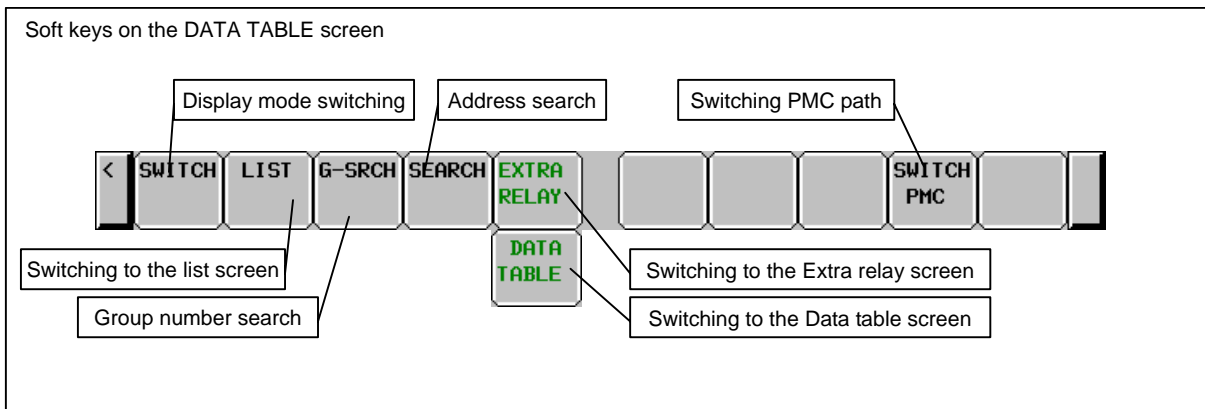

### EXTRA RELAY CONTROL screen ([LIST] screen)

To switch to the EXTRA RELAY CONTROL screen in which you can manage the extra relay tables, use [EXTRA RELAY] soft key in DATA TABLE CONTROL screen.

The operation of this screen is similar to the DATA TABLE CONTROL screen. See “DATA TABLE CONTROL screen ([LIST] screen)” for the detail of the operations.

To make it easy to distinguish the EXTRA RELAY CONTROL screen from DATA TABLE CONTROL screen, the EXTRA RELAY CONTROL screen has white background at the line of “GROUP TABLE COUNT”.

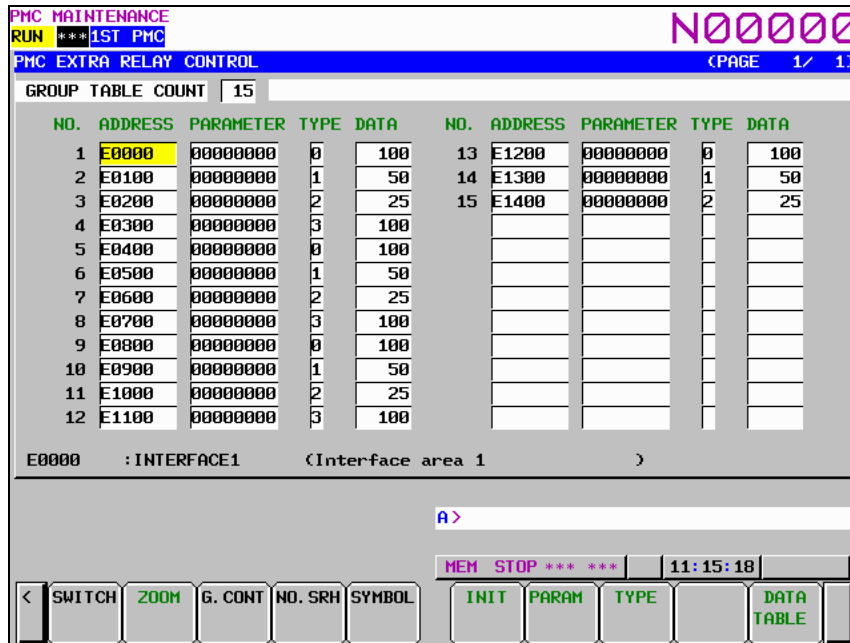

Fig. 6.5.6 (f) EXTRA RELAY CONTROL screen: simple display mode



### EXTRA RELAY screen ([ZOOM] screen)

When the extra relay control data are properly set, pressing [ZOOM] soft key at EXTRA RELAY CONTROL screen leads you to the EXTRA RELAY screen. Similarly to the DATA TABLE screen, this screen can show the contents of extra relays in three display modes; the simple display mode, the comment display mode, and the bit display mode.

The operation of this screen is similar to the DATA TABLE screen. See “DATA TABLE screen ([ZOOM] screen)” for the detail of the operations.

To make it easy to distinguish the EXTRA RELAY screen from DATA TABLE screen, the EXTRARELAY screen has white background at the line of the group information.

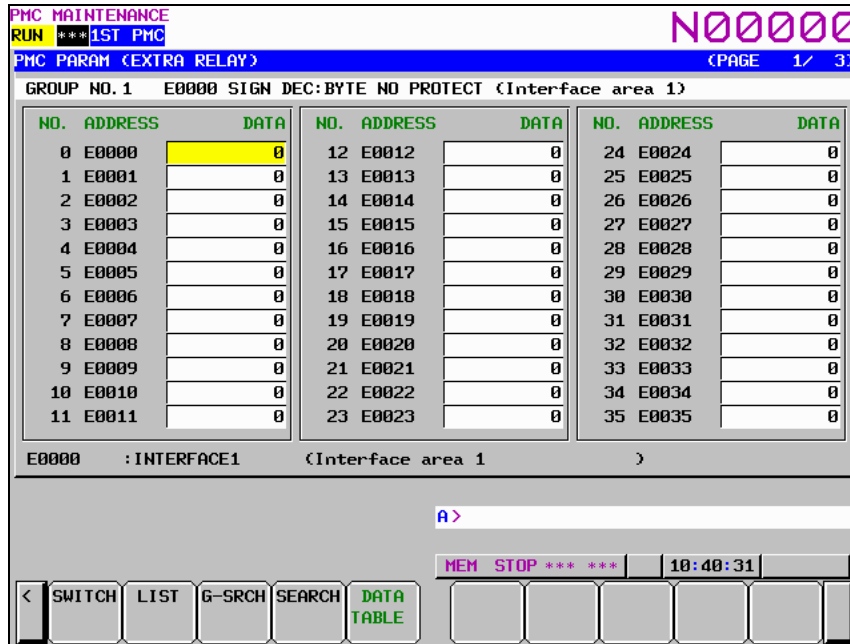

Fig. 6.5.6 (g) EXTRA RELAY screen: simple display mode

### 6.5.7 Data Input/Output ([I/O] Screen)

To move to the I/O screen, press the soft key [I/O].

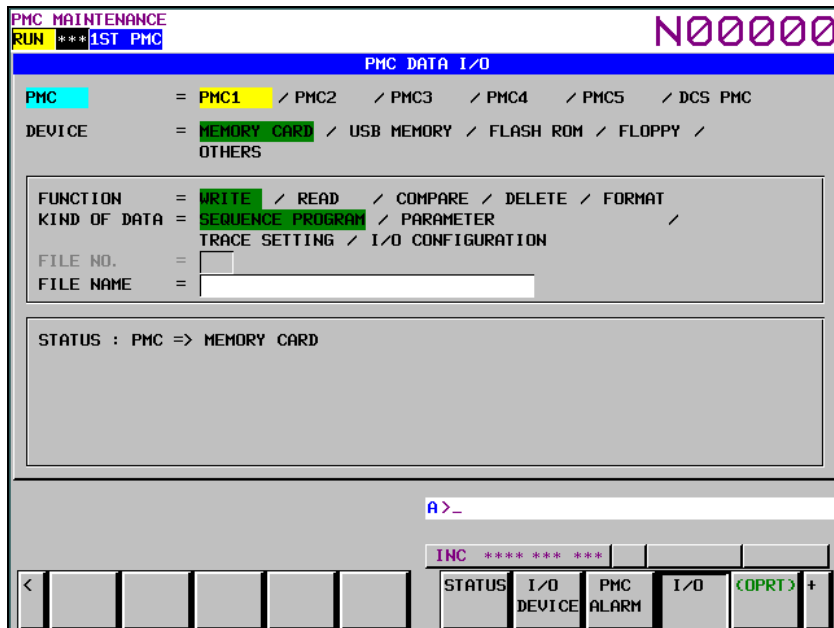

Fig. 6.5.7 (a) I/O screen

On this screen, sequence programs, PMC parameters, PMC message data for multi-language display, trace setting data and I/O configuration data can be written to the specified device, read from the device, and compared. The query selection cursor, which moves vertically from one question to another, is displayed, as is the option selection cursor, which moves horizontally from one option to another.

The following types of devices can be used for input/output. The desired device type can be selected by positioning the query selection cursor to "DEVICE" and moving the option selection cursor to that type.

- MEMORY CARD: Data can be output to and input from a memory card.
- USB MEMORY: Data can be output to and input from a USB memory.
- FLASH ROM: Data can be output to and input from flash ROM.
- FLOPPY: Data can be output to and input from handy files or floppy cassettes.
- OTHERS: Data can be output to and input from other general-purpose RS-232C input/output devices.

The multi-path PMC system enables an I/O target PMC to be selected. In STATUS in the lower part of the screen, a detailed explanation of execution and the execution status are displayed. During write, read, and comparison, the size of the data already transferred is indicated as the execution (intermediate) result. The Fig. 6.5.7 (b) gives a display example shown when PMC parameters are written to a memory card:

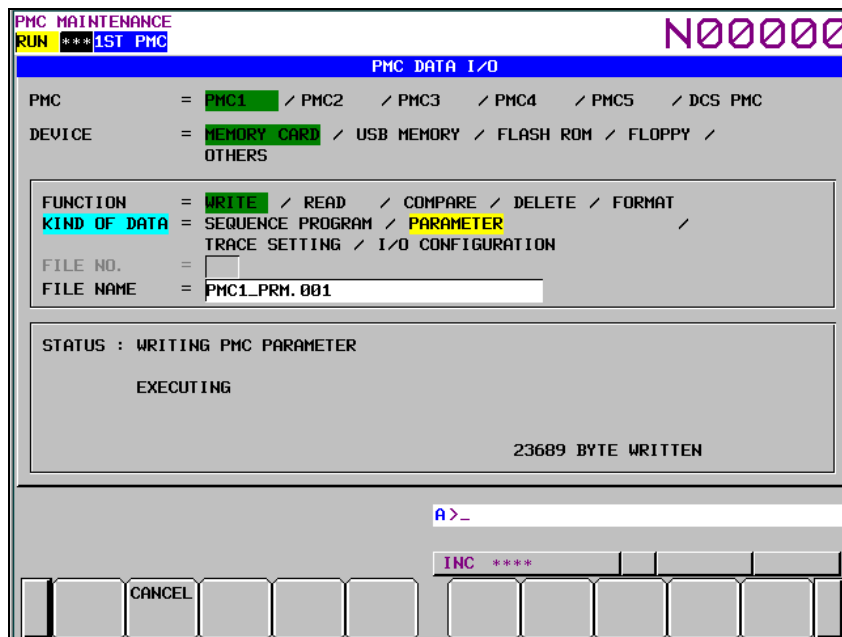
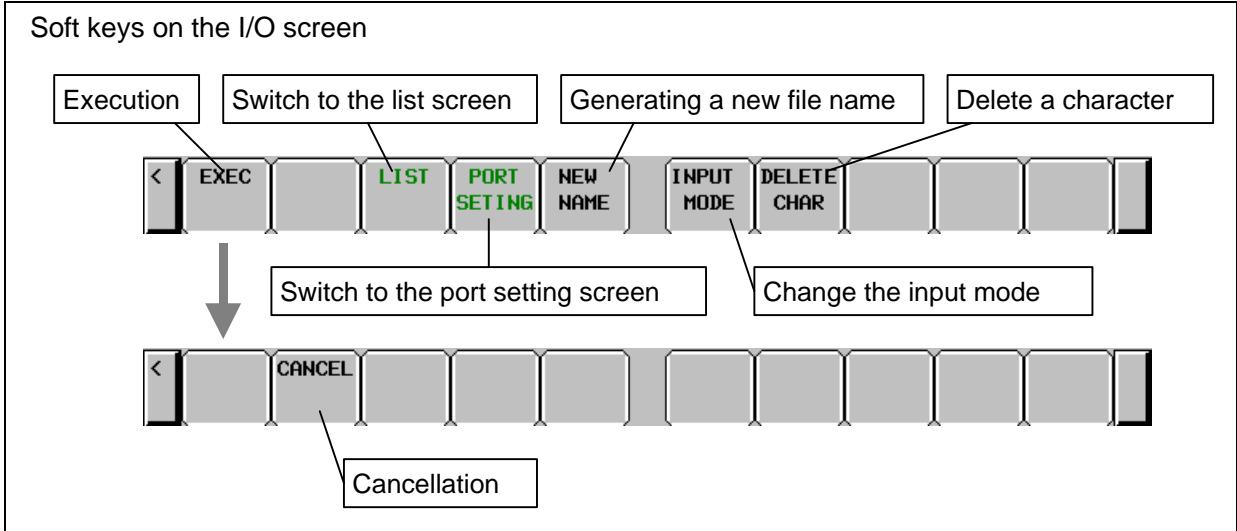

Fig. 6.5.7 (c) I/O screen



### 6.5.8 Displaying i/o devices connection status ([I/O DEVICE] screen)

I/O DEVICE MONITOR screen shows the types and the ID codes of I/O Units that are connected to I/O Link in order of Group number.

If the number of groups assigned in the I/O module assignment data does not match the number of actually connected groups, the difference is displayed on the screen.

When the I/O device configuration is registered in this screen, the difference between the registered groups and actually connected groups is displayed.

To switch the screen display to the I/O DEVICE MONITOR screen, press the [I/O DEVICE] soft key.

The screen supports the following operations.

- Registration of I/O device configuration [REG.]
- Deletion of I/O device configuration [DELETE]

**NOTE**  
The [REG.] and [DELETE] operations are performed for each channel separately.

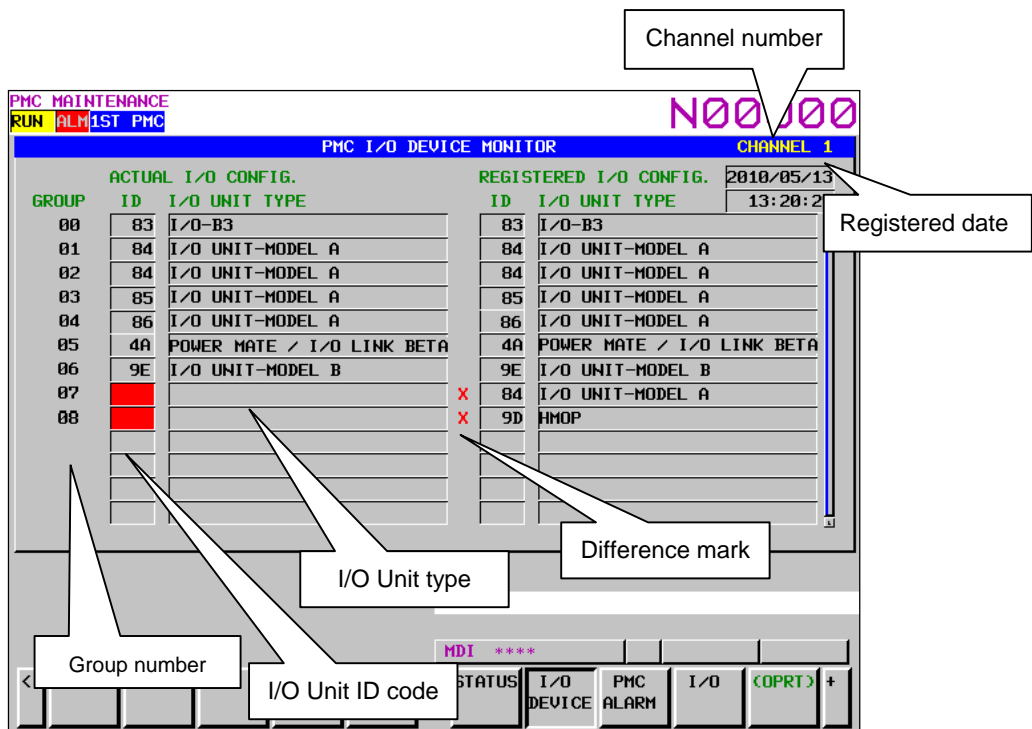

Figure 6.5.8 (a) I/O device screen

Table 6.5.8(a) Displayed type and actual type of I/O Units (for I/O Link)

Displayed I/O Unit	ID	Actual I/O Unit
CONNECTION UNIT	80	Connection Unit
OPERATOR PANEL	82	Connection Unit for Operators Panel
I/O-B3	83	I/O B3
IO UNIT-MODEL A	84 86 87	I/O Unit-MODEL A
POWER MATE / I/O LINK BETA	4A	Power Mate or I/O Link Beta
SERIES 0	50	Series 0
OPERATOR I/F BOARD (MPG1)	53	Machine Operators Panel Interface

Displayed I/O Unit	ID	Actual I/O Unit
LINK CONNECTION UNIT	96	I/O Link Connecting Unit
I/O UNIT-MODEL B	9E	I/O Unit-MODEL B
R-J MATE	61	R-J Mate
CONNECTOR PANEL MODULE	A9	I/O module for connector panel
OPERATOR PANEL A1	AA	I/O module for operator's panel
OPERATOR I/F BOARD (MPG3)	6B	Operator Interface (with MPG)
LOADER I/O	AF	I/O Board for Loader
FRC DIF	B0	DIF Board for ROBOCUT
FRC MIF	B1	MIF Board for ROBOCUT
I/O CARD	B2	I/O board
ROBOSHOT I/O CARD A	B3	I/O for ROBOSHOT
LOADER I/O (MATRIX)	B4	I/O Board for Loader (Matrix)
PROCESS I/O FA	B5	Process I/O for robot controller
PROCESS IO	89	Process I/O for robot controller
I/O LINK ADAPTER	8B	I/O Link adapter
ROBOT CONTROLLER	52	Controller for robot
OPERATOR PANEL	95	I/O for Series 0
LASER OSCILLATOR	97	Laser Oscillator
FIXED I/O TYPE A	98	I/O for Robot Type A
FIXED I/O TYPE B	99	I/O for Robot Type B
AS-I CONVERTER	77	AS-i Converter
OPERATOR PANEL B	A8	I/O Module (for Operator Panel 48/32)
MACHINE OPERATOR PANEL A	A8	I/O Module (for Machine Operator Panel of 0 Type)
CONNECTION UNIT C1 (MPG)	A8	Connection Unit C1 (with MPG)
MACHINE OPERATOR PANEL B	A8	I/O Module (for Machine Operator Panel)
I/O MODULE WITH LCD	A8	LCD display embedded I/O
UNKNOWN UNIT	-	Unknown I/O Unit

 **CAUTION**

- IDs other than those for the I/O units listed in Table 6.5.8(a) represent undefined units.
- I/O Units not for this CNC system are also written in Table 6.5.8(a).

**Table 6.5.8 (b) Displayed type of I/O Units (for I/O Link *i*)**

ID	Displayed I/O Unit
01	OP. PANEL (CABINET) I/O B
04	MACHINE OPERATORS PANEL
08	PANEL <i>i</i> AUTOMOTIVE SOFTKEY
0A	I/O MODULE TYPE-2
0B	I/O UNIT FOR 0 <i>i</i>
14	I/O BOARD SLAVE0
15	I/O BOARD SLAVE1
17	TERMINAL I/O MODULE
1E	OPERATORS PANEL
53	OPERATORS PANEL I/F BOARD
6B	OPERATORS PANEL I/F BOARD
77	I/O LINK ASI CONVERTER
96	CONNECTION UNIT
A9	I/O FOR CONNECTOR PANEL
AA	I/O FOR OPERATORS PANEL A
AB	MULTISENSOR UNIT
B8	LASER OSCILLATOR
C6	I/O FOR OP. PANEL (DCS)

ID	Displayed I/O Unit
C7	I/O FOR OP. PANEL (DCS)_S
C8	SAFETY IO UNIT
D0	I/O UNIT-MODEL A
D8	I/O UNIT-MODEL B
D9	HANDY MACHINE OP. PANEL

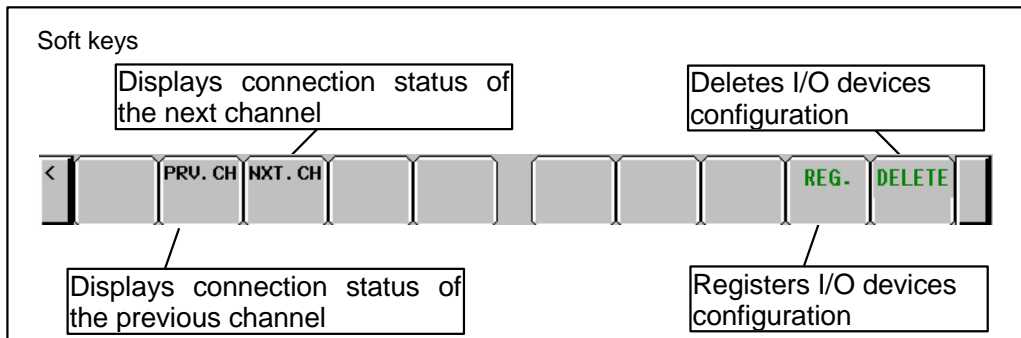

### 6.5.9 Signal Trace Function ([TRACE] Screen)

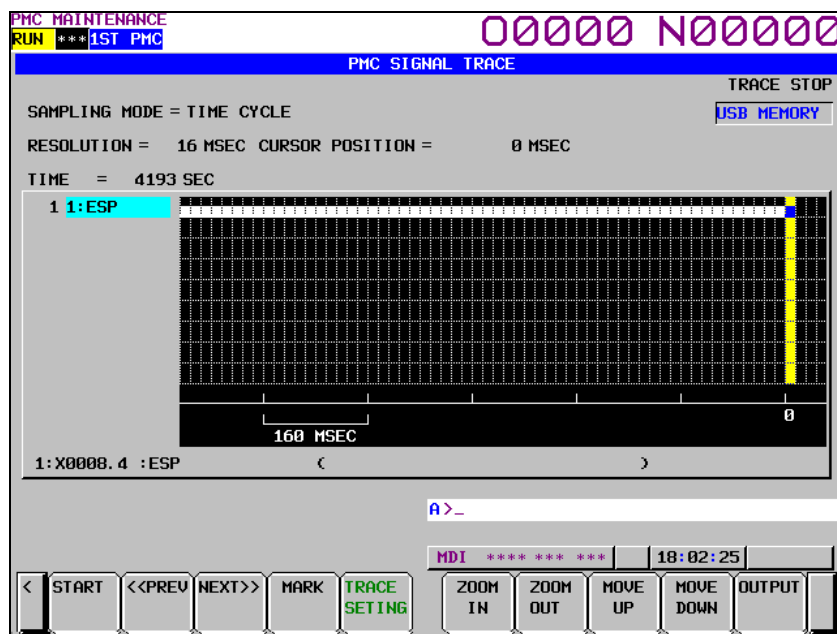

Fig. 6.5.9 (a) Signal trace screen (initial screen)

Before trace operation can be executed, the trace parameters must be set. Press the soft key [TRACE SETING] to switch the screen display to the trace parameter setting screen. By setting the PMC setting screen, the trace function can be automatically started after the power is turned on. In this case as well, the trace parameters must be set beforehand.

**NOTE**

For the setting to automatically start the trace function after the power is turned on, see Subsection 7.5.11.2.

## 6.5.10 Setting of Trace Parameter ([TRACE SETING] Screen)

On the trace parameter setting screen, a sampling condition can be set. The screen consists of two pages. Use the page keys to switch between the pages.

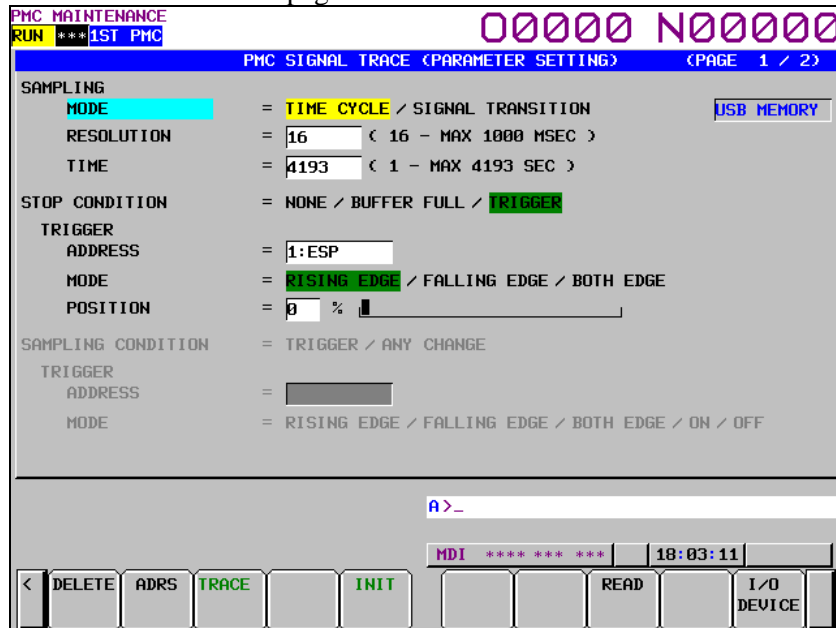

Fig. 6.5.10 (a) Trace parameter setting screen (first page)

- (a) **SAMPLING/ MODE**  
Determines the sampling mode.
- **TIME CYCLE:** Samples at every specified cycle time.
  - **SIGNAL TRANSITION:** Monitors the signal at a set cycle and samples when the signal makes a transition.
- (b) **SAMPLING/ RESOLUTION**  
The resolution of sampling is inputted. The default value is the minimum sampling resolution (msec), which varies depending on the CNC.  
Setting range: Minimum sampling resolution to 1000 (msec)  
An input value is rounded off to a multiple of the minimum sampling resolution (msec) which is closest to but not greater than the input value.
- (c) **SAMPLING/ TIME**  
This parameter is displayed when "TIME CYCLE" is set on "SAMPLING/ MODE". The execution time of trace is inputted. The value of "SAMPLING/ RESOLUTION" or the number of specified signal address changes the range of the value that is able to input. The range is displayed on the right side.
- (d) **SAMPLING/ FRAME**  
This parameter is displayed when "SIGNAL TRANSITION" is set on "SAMPLING/ MODE". The number of sampling is inputted. The value of "SAMPLING/ RESOLUTION" or the number of specified signal addresses changes the range of the value that is able to input. The range is displayed on the right side.
- (e) **STOP CONDITION**  
Determines the condition to stop the trace.
- **NONE:** Does not stop the tracing automatically.
  - **BUFFER FULL:** Stops the tracing when the buffer becomes full.
  - **TRIGGER:** Stops the tracing by trigger.
- (f) **STOP CONDITION/ TRIGGER/ ADDRESS**  
When "TRIGGER" is set on "STOP CONDITION", this parameter is enabled. Input signal address or symbol name as stop trigger.  
A PMC number can be set for a trigger address by entering the PMC number at the time of address setting.

Example: "2:R9200.1" + Input key

A setting can be made by entering "PMC number" + ":" + "address" as indicated above.

(g) STOP CONDITION/ TRIGGER/ MODE

When "TRIGGER" is set on "STOP CONDITION", this parameter is enabled. Determine the trigger mode when the trace is stopped.

- RISING EDGE: Stops the tracing automatically by rising up of the trigger signal.
- FALLING EDGE: Stops the tracing automatically by falling down of the trigger signal.
- BOTH EDGE: Stops the tracing automatically by rising up or falling down of the trigger signal.

(h) STOP CONDITION/ TRIGGER/ POSITION

When "TRIGGER" is set on "STOP CONDITION", this parameter is enabled. Input the ratio of the sampling time or number which specifies the position where specified trigger condition is on. If you would like to examine the transitions of the signal before the trigger condition, you should set a big value in this parameter. If you would like to examine the transitions of the signal after the trigger condition, you should set a small value in this parameter.

Example: The case that sampling time is 10 seconds and trigger position is set as "10%".

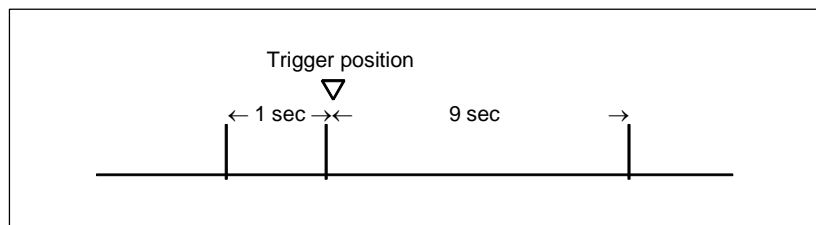

(i) SAMPLING CONDITION

When "SIGNAL TRANSITION" is set on "TRACE MODE", this parameter is enabled. Determine the sampling condition.

- TRIGGER: Samples the status of specified signals when the specified sampling condition is on.
- ANY CHANGE: Samples the status of specified signals when the signals change.

(j) SAMPLING CONDITION/ TRIGGER/ ADDRESS

When "SIGNAL TRANSITION" is set on "TRACE MODE", and "TRIGGER" is set on "SAMPLING CONDITION", this parameter is enabled. Input signal address or symbol name as sampling trigger.

A PMC number can be set for a trigger address by entering the PMC number at the time of address setting.

Example: "2:R9200.1" + Input key

A setting can be made by entering "PMC number" + ":" + "address" as indicated above.

(k) SAMPLING CONDITION/ TRIGGER/ MODE

When "SIGNAL TRANSITION" is set on "TRACE MODE", and "TRIGGER" is set on "SAMPLING CONDITION", this parameter is enabled. Input trigger mode that determines the condition of specified trigger.

- RISING EDGE: Samples the status of specified signals by rising up of the trigger signal.
- FALLING EDGE: Samples the status of specified signals by falling down of the trigger signal.
- BOTH EDGE: Trigger signal.
- ON: Samples the status of specified signals during the trigger signal is on.
- OFF: Samples the status of specified signals during the trigger signal is off.

In page 2 of the Parameter Setting screen, you can set the addresses or symbols that should be sampled.



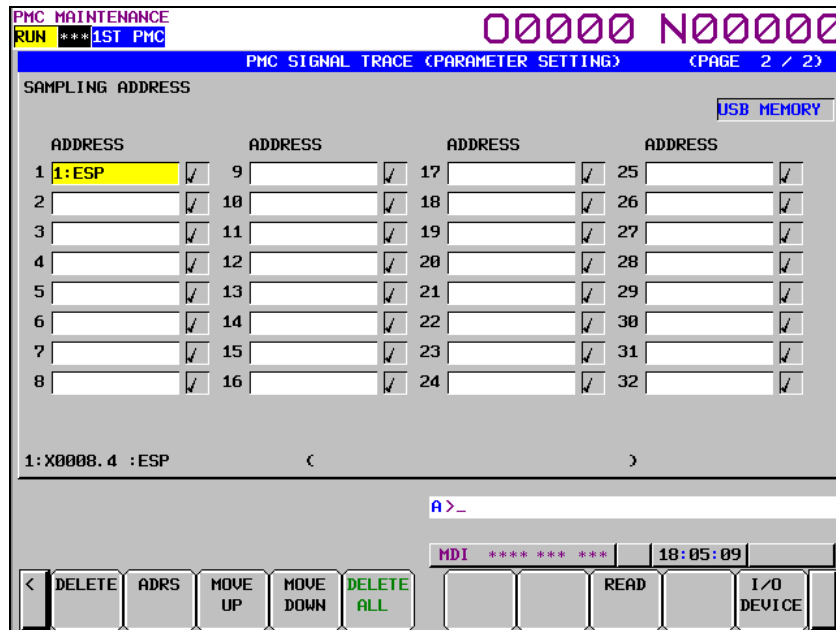

Fig. 6.5.10 (b) Trace parameter setting screen (second page)

(a) Setting addresses

In case of inputting discrete bit addresses, any bit address can be inputted.

Moreover, when you input byte address, all bits of the address (bits 0 to 7) are set automatically. Maximum 32 points of signal address can be inputted.

With the multi-PMC system, an address can be set for a desired PMC by specifying its PMC number.

Example: 2:R9200.1 + Input key

A setting can be made by entering "PMC number" + ":" + "address" as indicated above.

In case of DCSPMC, enter "S:"+"address".

When no PMC number is specified, the specification of the currently selected PMC is assumed. In this case, "PMC number" + ":" is automatically prefixed to a specified address.

When only one PMC is used as in the standard PMC system, no PMC number needs to be specified.

**NOTE**

- 1 For the PMC numbers, see Section 7.2.
- 2 If there is not ":" key on your keyboard, use ";" or "/" instead.
- 3 Increasing the number of the signal address changes the capacity of "SAMPLING/ TIME" or "SAMPLING/ FRAME" in page 1. If the capacity is changed, the following warning message is displayed. (The "n" on the message means the maximum value that is able to input.)
  - a) In case of "TIME CYCLE" mode  
"SAMPLING TIME IS REDUCED TO n SEC."
  - b) In case of "SIGNAL TRANSITION" mode  
"SAMPLING FRAME IS REDUCED TO n."
- 4 The signal trace for the DCSPMC is executed in the same timing as signals of 1st to 5th paths PMC.

**CAUTION**

The signal trace of the DCSPMC does not synchronize with the ladder execution period of the DCSPMC. Therefore, when plural signals are traced, the timing of tracing may not be accurate.

## b) Soft keys

Soft keys on the setting screen of sampling address are as follows

- DELETE : Clears the value of the edit box on the cursor.
- SYMBOL/ADDRESS : Changes the address display to the symbol display. However, display of the address that is not defined the symbol does not change. This soft key also changes to "ADDRESS". The following soft keys are displayed.
- MOVE UP : Exchanges the signal indicated the cursor for the signal above one line.
- MOVE DOWN : Exchanges the signal indicated the cursor for the signal below one line.
- DELETE ALL : Clears all of the value of the edit box.
- READ : Reads the trace setting files.
- I/O DEVICE : Selects input device of the trace setting file and output device of the trace result data. Pressing the soft-key switches "memory card" or "USB memory" alternately.

## c) Trigger setting

When "SIGNAL TRANSITION" is set on "TRACE MODE" and "ANY CHANGE" is set on "SAMPLING CONDITION", it can be set whether to use the setting address as the signals that should trigger the sampling in the setting signals. As for the signal address where the trigger was set, "✓" is displayed right. Soft keys on the Trigger setting screen are as follows:

- TRGON: Sets the Trigger on.
- TRGOFF: Sets the Trigger off.

The default setting is trigger on for all signals.

## 6.5.11 Execution of Trace

After the trace parameters are set, a trace operation can be started by pressing the soft key [(OPRT)] and the soft key [RUN] on the SIGNAL TRACE screen. The following is the screen examples of the trace execution by "TIME CYCLE" mode and "SIGNAL TRANSITION" mode.

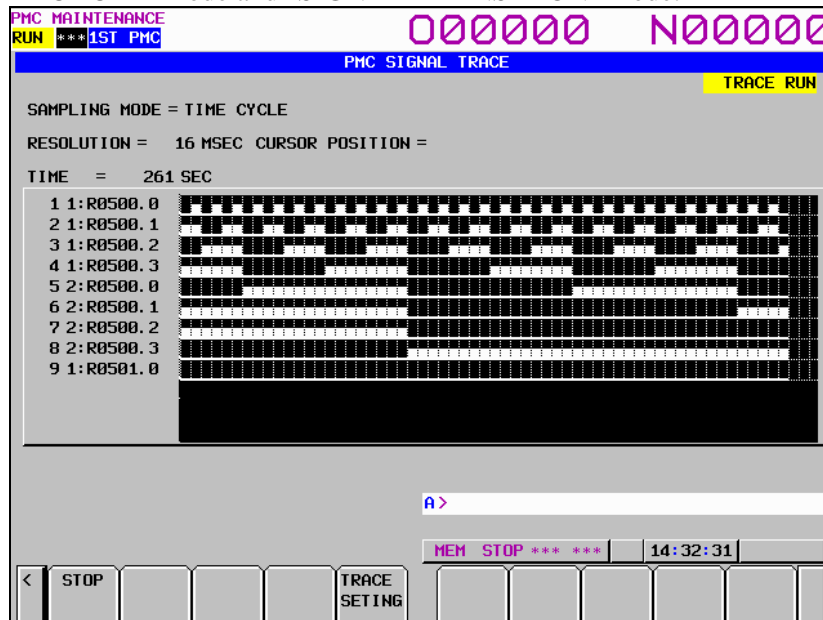

Fig. 6.5.11 (a) Trace execution screen (TIME CYCLE mode)

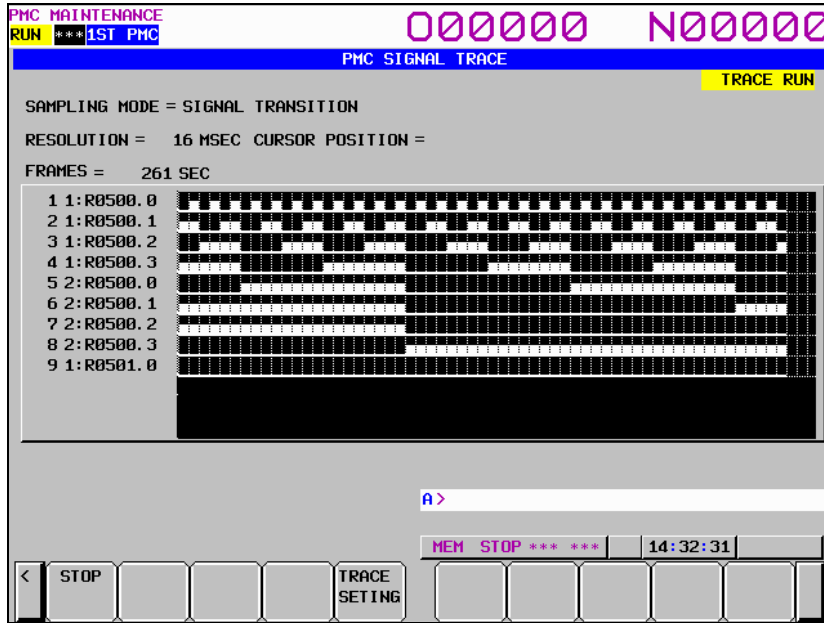

Fig. 6.5.11 (b) Trace execution screen (SIGNAL TRANSITION mode)

The result of trace is immediately displayed during execution of the trace. When the stop conditions that is set in parameter setting screen is satisfied the execution is finished. Pushing soft key [STOP] aborts the execution. In "SIGNAL TRANSITION" mode, graphic display is not refreshed until any signal for sampling trigger changes.

### 6.5.11.1 Operation after execution of trace

When the execution is finished, the result of trace is displayed. The Fig. 6.5.11.1 (a) and Fig. 6.5.11.1 (b) are the screen examples of trace by "TIME CYCLE" and "SIGNAL TRANSITION" mode.

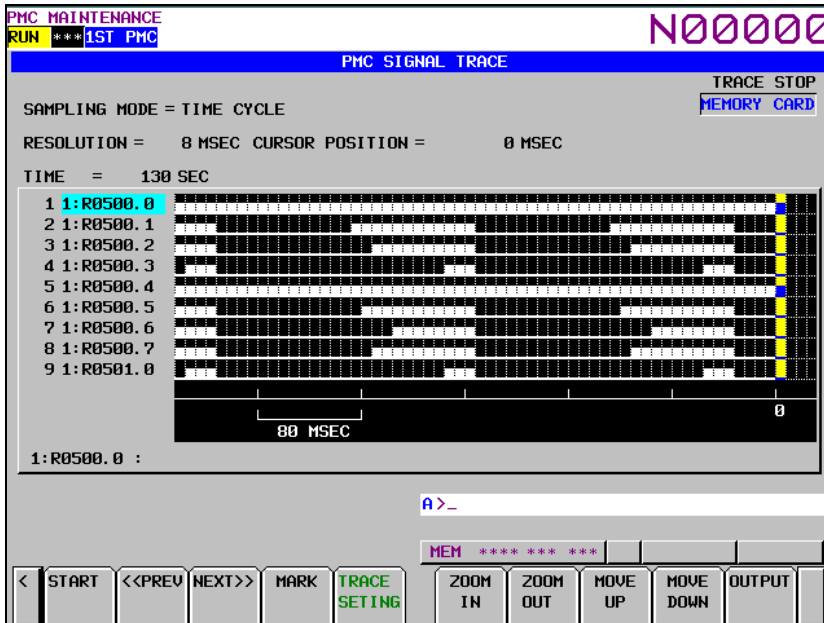

Fig. 6.5.11.1 (a) Trace result screen (TIME CYCLE mode)

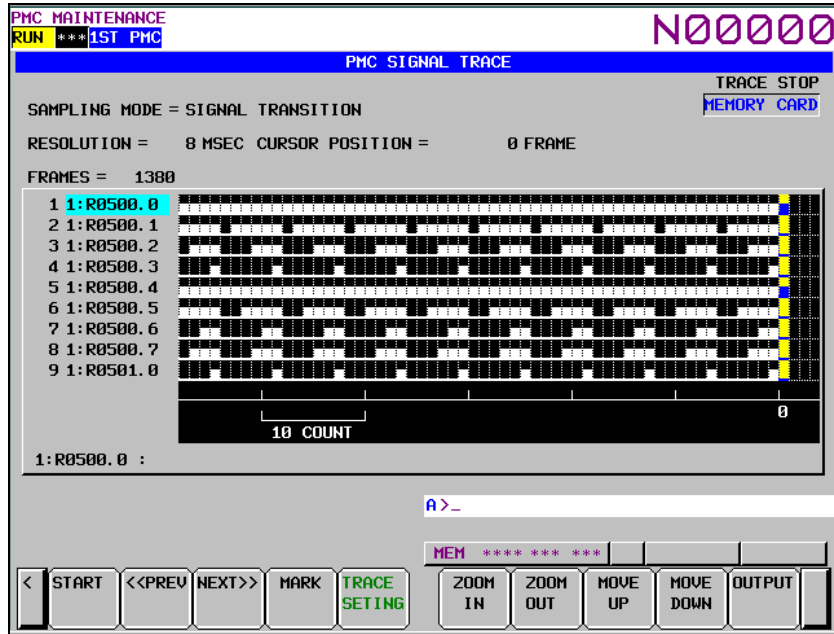

Fig. 6.5.11.1 (b) Trace result screen (SIGNAL TRANSITION mode)

The cursor indicating current position is initially displayed on the original point (0 point). The position of the cursor is displayed in "CURSOR POSITION" in the upper of the screen. The cursor can move horizontally with the <<-> or <->> key. After the execution, following operation is enabled.

a) Scroll of screen

- Cursor up/down key and Page up/down key  
Enables the vertical scroll for the specified signal
- Cursor right/left key, soft key [NEXT>>] and soft key [<< PREV]  
Enables the horizontal scroll of the graph.

b) Automatic calculation of the selected range

Pushing soft key [MARK] marks the current position and displays the mark cursor.

If the mark cursor duplicates with the current position cursor, the current position cursor has priority of display. The "MARK POSITION" that shows the position of the mark cursor and "RANGE" that shows the range between the mark cursor and the current position cursor are displayed in the upper of screen.

Moving the current position cursor changes these values. Pushing soft key [MARK] again releases the select range mode.

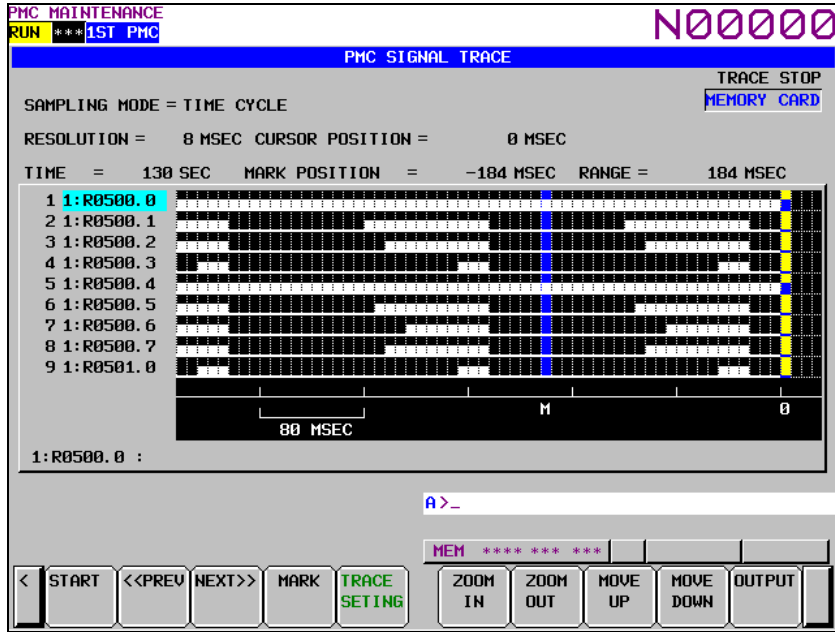

Fig. 6.5.11.1 (c) Trace result screen (Mark cursor display)

- c) Zoom in/Zoom out of waveform  
 Pushing soft key [ZOOM IN] magnifies the display of chart. Pushing soft key [ZOOM OUT] reduces the display of chart. Pushing these soft keys also change the scale value of the graduation on the graph. When trace is just finished, the default zooming level was the most magnified level. In [ZOOM OUT] mode, "X" is displayed as following screen example when the transitions of signal cannot be expressed accurately enough. The limitation of [ZOOM OUT] displays all of result of the trace in one page.

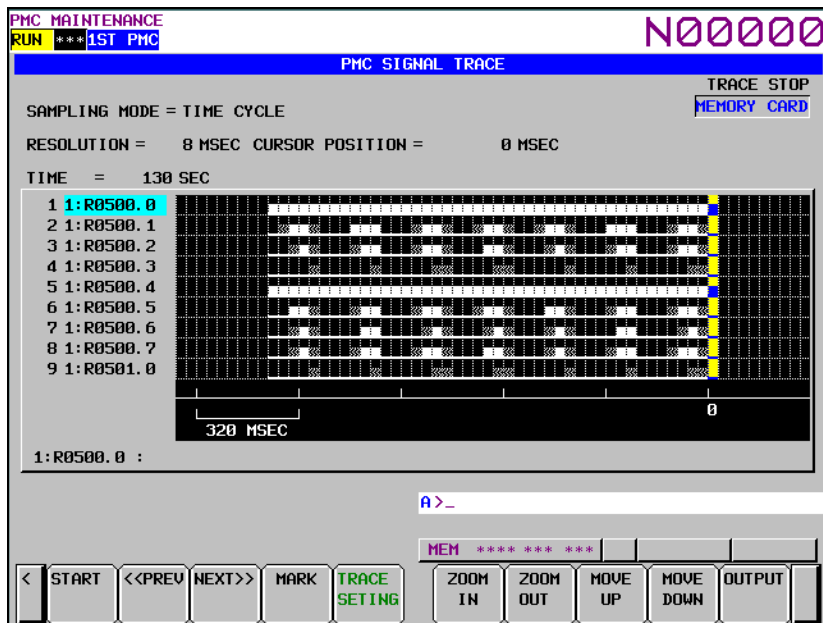

Fig. 6.5.11.1 (d) Trace result screen (Zoom out display)

- d) Exchange of sampling signal  
 Pushing soft key [MOVE UP] exchanges the signal indicated by the signal cursor for the signal one line above. Pushing soft key [MOVE DOWN] exchanges the signal indicated by the signal cursor for the signal one line below. The result of the operation is cancelled by the execution of trace or putting the power off. When you would like to preserve the order of displayed signals against the executing or powering off, please change the order on "SAMPLING ADDRESS" screen.

- e) Output of the trace result data  
Pressing the [OUTPUT] soft key outputs the trace result data to “memory card” or “USB memory”.

### 6.5.11.2 Automatic start of trace setting

Trace execution is automatically started after power-on by setting a PMC setting data.

- TRACE START = MANUAL/AUTO

#### NOTE

For details of the method of setting PMC setting data, see PMC PROGRAMMING MANUAL (B-64513EN).

## 6.5.12 MONITORING I/O DIAGNOSIS ([I/O DGN] SCREEN)

In I/O Diagnosis screen, you can check the status of each I/O variable. You can also check the configuration of I/O devices and the communication status with them.

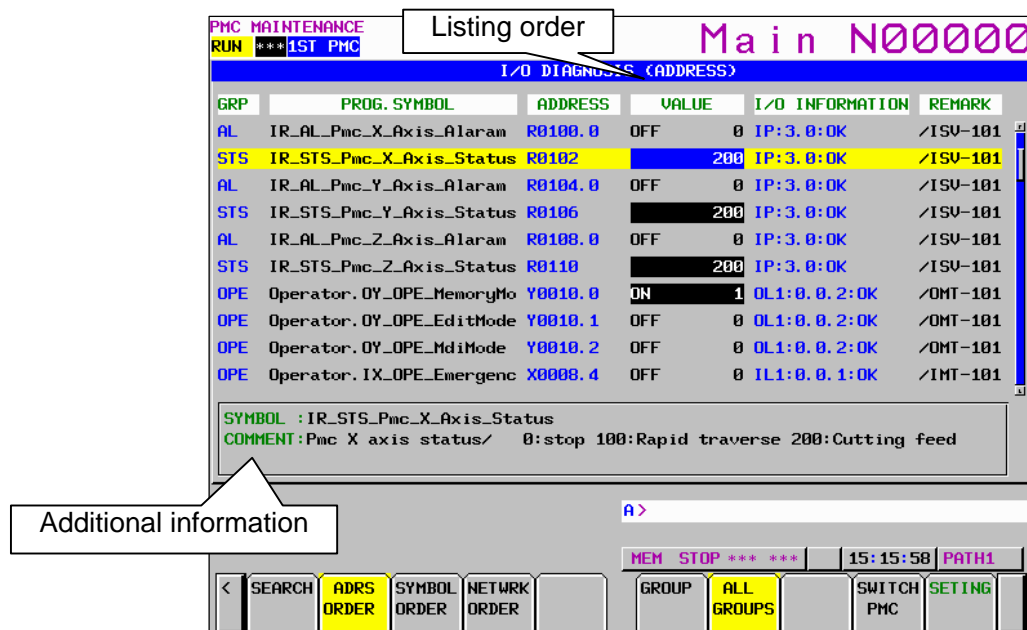

Fig. 6.5.12 (a) I/O diagnosis screen

#### GRP (GROUP)

To include a specific string which means a kind of signals in a part of symbol string, these signals on I/O diagnosis screen are classified and you can easily understand the status of signals.

The group names of the I/O variables are displayed, which are extracted (Max. 4 chars) out of their symbol names as configured in “GROUP FORMAT” in the setting screen.

The groups to be displayed can be specified by soft key.

[ALL GROUPS] All groups are displayed.

[GROUP] The group entered by key or the group under the cursor is selected to be displayed.

#### PROG.SYMBOL (SYMBOL)

The symbol names of the I/O variables are displayed.

#### ADDRESS

The actual locations of I/O variables are displayed.

**VALUE**

The current values of I/O variables are displayed as signed decimal, according to the data type of them (i.e. BOOL, BYTE, WORD, and DWORD).

**I/O INFORMATION**

The information related to I/O network is displayed in the display format below:

<I/O type><Network type> : <Network address> : <status>

**I/O type:**

Module type	Shown as
Input module	I
Output module	O
Other	*

**Network type:**

Network type	Shown as
PROFIBUS	P
I/O LINK	<i>Ln (n: channel number)</i>
I/O LINK <i>i</i>	<i>Ln (n: channel number)</i>

**Network address:**

Network type	Network address notation
PROFIBUS	<i>&lt;Slave #&gt;.&lt;Slot #&gt;</i>
I/O LINK	<i>&lt;Group #&gt;.&lt;Base #&gt;.&lt;Slot #&gt;</i>
I/O LINK <i>i</i>	<i>&lt;Group #&gt;.&lt;Slot #&gt;</i>

**NOTE**

This screen shows the I/O information according to the network setting that became effective at the time of the last power-on.

The notes for each network device are as follows:

**PROFIBUS**

1. If you have changed some of the profibus parameters, you have to cycle the power once to make the changes take effect.

**I/O LINK**

1. Only the I/O Link assignments, which are made effective by the setting of "Machine Signal Interface" in Configuration Parameter menu and the setting of "Communication method of I/O Link" in NC Parameter and the setting of "Selectable I/O Link Assignment Function", are displayed.
2. If you have changed the following parameters, you have to cycle the power once to make them take effect:
  - "I/O Link assignment data"
  - "Machine signal interface" in PMC configuration parameter
  - Parameter of "Selectable I/O Link assignment function"
3. If you have stored new sequence program to PMC, its I/O Link assignment data will not take effect until you write it into Flash-ROM and cycle the power once.

**I/O Link *i***

1. Only the I/O Link *i* assignments, which are made effective by the setting of "Communication method of I/O Link" in NC Parameter and the setting of "Selectable I/O Link *i* Assignment Function", are displayed.
2. If you have changed the following parameters, you have to cycle the power once to make them take effect:
  - "I/O Link *i* assignment data"
  - "Communication method of I/O Link" in NC Parameter
  - Parameter of "Selectable I/O Link *i* assignment function"
3. If you have stored new I/O configuration data to PMC, its I/O Link *i* assignment data will not take effect until you write it into Flash-ROM and cycle the power once.

**Status:** the status of communication  
"OK" or "NG" is displayed.

**REMARK**

The remarks up to 8 characters extracted from comment data are displayed. To specify the remark at this field, set "100" to the attribute value of the comment, which you want to show in this field, on FANUC LADDER-III,

**Additional information window**

In this window, symbol and comment of the I/O variable under the cursor are displayed. When language dependent comment attributes are specified, corresponding comment is displayed according to the current language setting of the CNC.

In FANUC LADDER-III, the attribute value of comment should be set to 0 to 18 to display language dependent comment



Attribute value: 0 to 18

0: English	10: Portuguese
1: Japanese	11: Polish
2: German	12: Hungarian
3: French	13: Swedish
4: Chinese (Traditional)	14: Czech
5: Italian	15: Chinese (Simplified)
6: Korean	16: Russian
7: Spanish	17: Turkish
8: Dutch	18: Bulgarian
9: Danish	

**NOTE**

In case of the extended symbol and comment, the comments on the screen will be switched dynamically to new language when the language setting of CNC changes.

Soft key

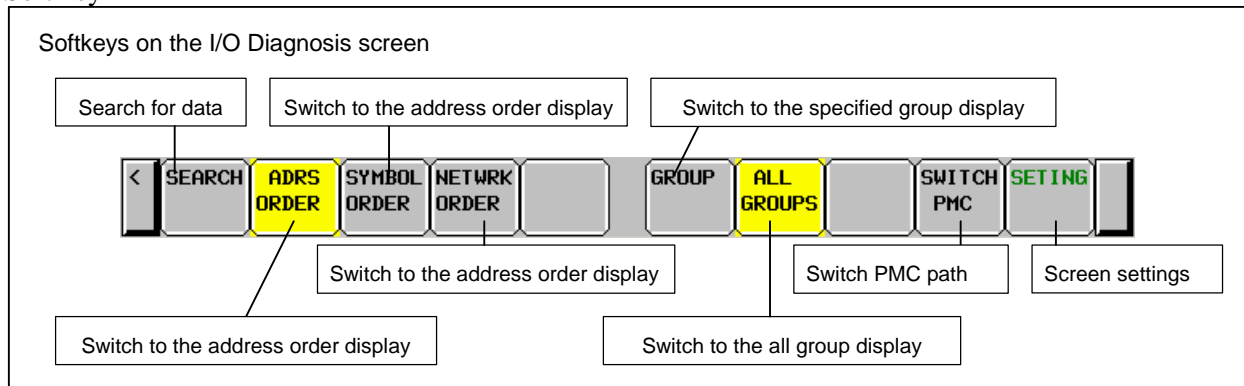

## 6.6 LADDER DIAGRAM MONITOR AND EDITOR SCREENS ([PMC LADDER])

The PMC LADDER menu contains the screens related to PMC Ladder diagrams, such as the program list screen and the LADDER DIAGRAM MONITOR/EDITOR screens.

You can switch to the PMC LADDER menu by operating on the "SYSTEM" key and then the soft key [PMC LADDER].

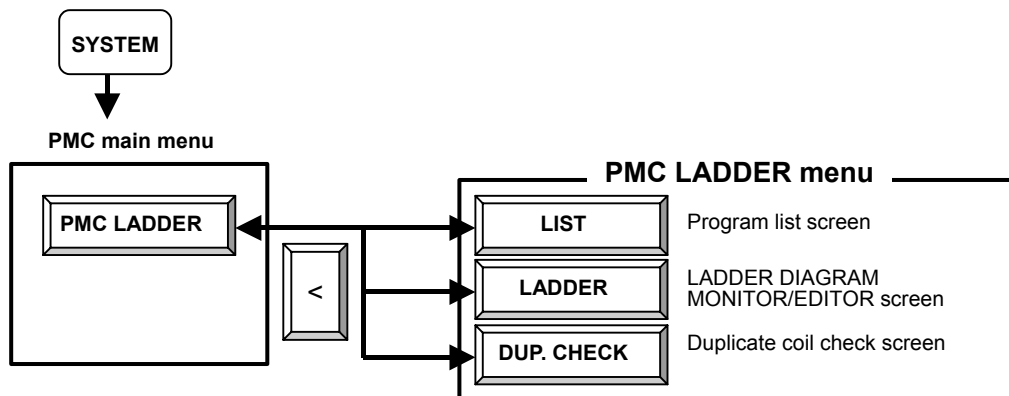

Fig. 6.6 (a) PMC LADDER menu

Clicking the soft key [LADDER] causes the sequence program to be dynamically displayed, allowing you to monitor operation. The editor screen allows you to make changes to relay and functional instructions in the sequence program to change the operation of the sequence program.

The ladder diagram display/editor functions consist of the following screens:

- (1) LADDER DIAGRAM MONITOR screen  
Displays ladder diagrams to monitor the current states of relays, coils, and so on.
- (2) COLLECTIVE MONITOR screen  
Displays only a selected ladder net to monitor the current states of relays, coils, and so on.
- (3) LADDER DIAGRAM EDITOR screen  
Allows you to edit a ladder diagram in units of nets.
- (4) NET EDITOR screen  
Allows you to edit a single net in a ladder diagram.
- (5) PROGRAM LIST VIEWER screen  
Allows you to select the subprogram to be displayed on the LADDER DIAGRAM MONITOR screen.
- (6) PROGRAM LIST EDITOR screen  
Allows you to edit a ladder program in units of subprograms. Also allows you to select the subprogram to be edited on the LADDER DIAGRAM EDITOR screen.

The following screens can be called from the LADDER DIAGRAM EDITOR screen:

- (7) FUNCTIONAL INSTRUCTION DATA TABLE VIEWER screen  
Allows you to view the contents of the data table for a data table attached functional instruction.
- (8) FUNCTIONAL INSTRUCTION DATA TABLE EDITOR screen  
Allows you to edit the contents of the data table for a data table attached functional instruction.
- (9) SUBPROGRAM LIST VIEWER screen  
Displays the list of the called subprogram and the subprogram switching history.

### NOTE

You can protect these screens by using the programmer protection function. For details, see PMC PROGRAMMING MANUAL (B-64513EN).

You can move among screens as shown in the Fig. 6.6 (b).

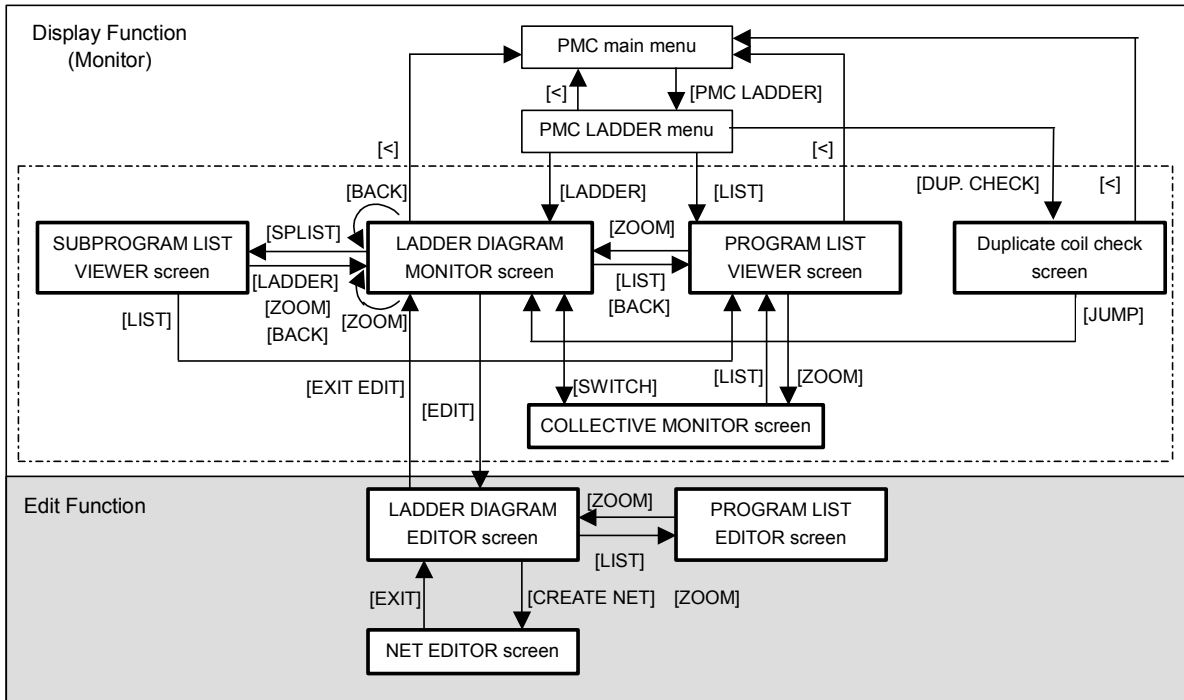

Fig. 6.6 (b) Transition among screens

**NOTE**  
 The [EDIT] soft key on the LADDER DIAGRAM MONITOR screen is displayed and becomes available if the programmer protection function enables to edit ladder program. For details, see PMC PROGRAMMING MANUAL (B-64513EN).

### 6.6.1 Displaying a Program List ([LIST] Screen)

The PROGRAM LIST VIEWER screen shows program information such as the program size.

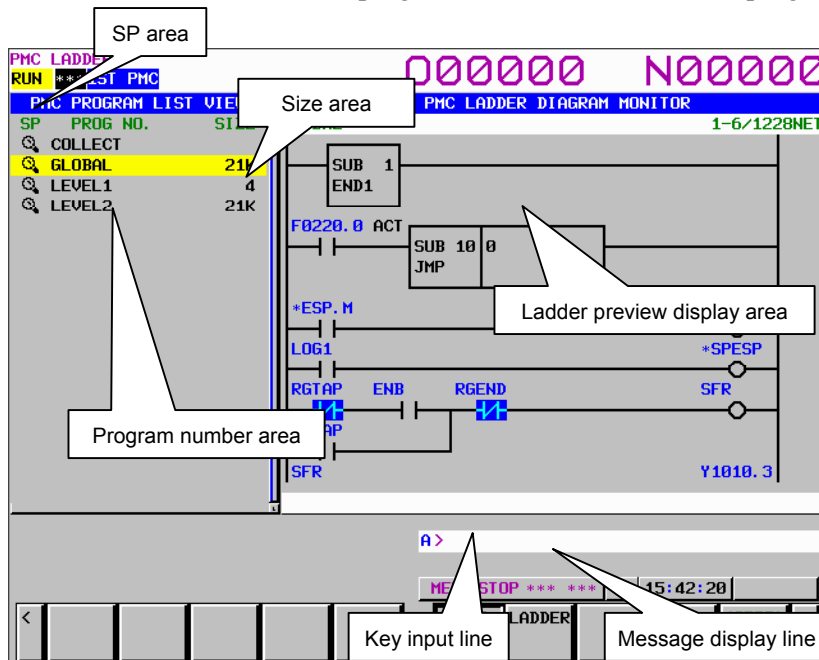



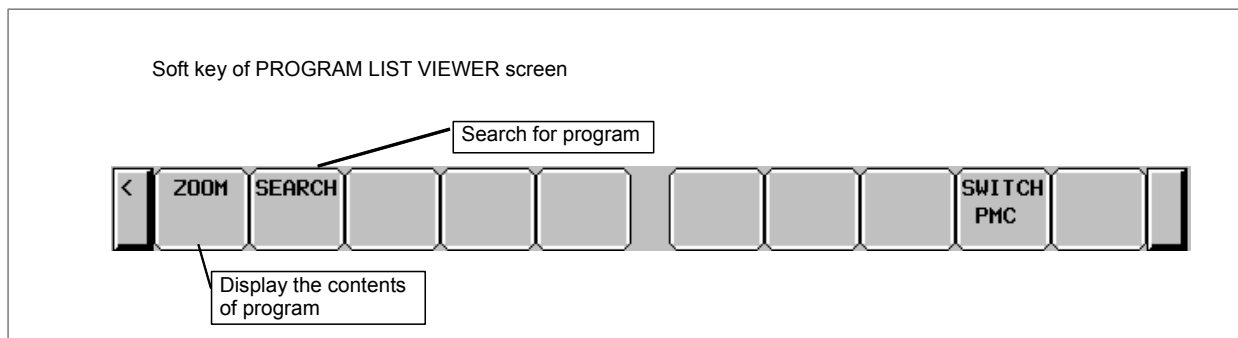

Fig. 6.6.1 (a) Program list viewer screen

- (1) Screen structures
  - (a) A program list is displayed on the left side of the screen; on the right side, the ladder diagram of the program currently indicated by the cursor on the program list is displayed.
  - (b) In the message line, error messages or inquiry messages will be displayed depending on the situation.
  - (c) The program list displays up to 18 programs at a time in the list display area.
- (2) Area of program list
  - (a) In the "SP area", the protect information for subprograms is displayed, so are their program types.
    -  (Key): Ladder program, cannot be viewed, cannot be edited
    -  (Magnifying glass): Ladder program, can be viewed, cannot be edited
    -  (Pencil): Ladder program, can be viewed, can be edited
  - (b) Program name is displayed in the "PROG NO." field for each program. There are three kinds of program names.
    - COLLECT: It means the collective program.
    - GLOBAL: It means the whole program.
    - LEVELn (n = 1, 2, 3): It means the Ladder level 1, 2 and 3.
    - Pm (m = subprogram number): It means subprogram.
 By changing the "ADDRESS NOTATION" item on the LADDER DIAGRAM MONITOR Setting screen to "SYMBOL", you can display symbols.
  - (c) The program size is displayed in the "SIZE" field for each program.
    - If the program size is not over 1024 byte, the unit is shown in byte.
    - If it is over 1024 byte, the unit is shown in kilo (1024) byte with "K".
    - Ex.) The case that program size is not over 1024 byte.
      - 1023 bytes: "1023" is shown.
    - Ex.) The case that program size is over 1024 byte.
      - 20000 bytes: "19K" is shown.
 (Sizes are rounded off to whole numbers before being displayed.)



## 6.6.2 Monitoring Ladder Diagrams ([LADDER] Screen)

LADDER DIAGRAM MONITOR screen shows the on/off status of contacts and coils, and the contents of address specified for parameter of functional instructions.

From the PMC LADDER menu, you can switch to the LADDER DIAGRAM MONITOR screen by using the soft key [LADDER]. You can use following operation at this screen, including "Forced I/O function (Forcing mode)", by which you can force the relay or the address parameters of functional instructions to a new status or value.

- Switch subprogram to show [LIST]
- Search for address or others [SEARCH MENU]
- Show data table of functional instructions [DATA TABLE]
- Go to COLLECTIVE MONITOR Screen [SWITCH]
- Forced I/O function (Forcing mode) "number" + INPUT key

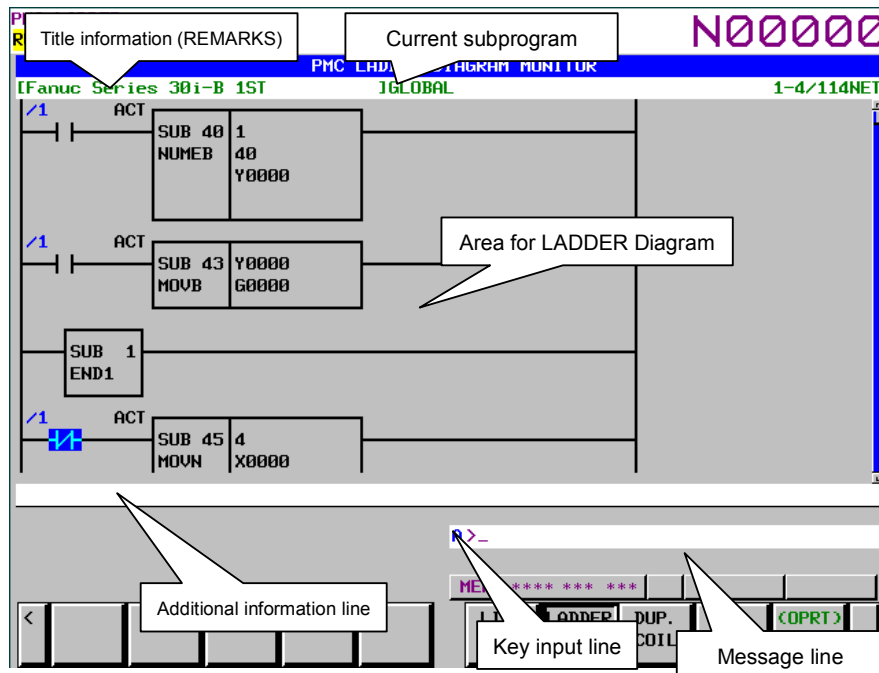

Fig. 6.6.2 (a) Ladder diagram monitor screen

(1) Screen structures

- (a) Title information (REMARKS) of the LADDER Program, the current subprogram, and the current position information of the Diagram displayed in this screen, are displayed above the LADDER Diagram.

When you select a subprogram to be displayed, range for search function is indicated at right of the top line as "LOCAL" or "GLOBAL". In case of "LOCAL", the range for search function is restricted within the current subprogram. In case of "GLOBAL", on the other hand, search function searches whole of LADDER program, and switch current subprogram automatically according to the result of searching.

- (b) In the additional information line near the bottom of the screen, the following information of the address under the cursor when the cursor is shown.
- Net number of the net with the cursor
  - Address and its symbol and comment information
  - Current value
- (c) In the message line, error messages or inquiry messages will be displayed depending on the situation.
- (d) In the area for LADDER diagrams,  $8 \times 8$ ,  $8 \times 6$ ,  $8 \times 4$ ,  $7 \times 8$ ,  $7 \times 6$ , and  $7 \times 4$  relays can be displayed (horizontally and vertically). For details, see PMC PROGRAMMING MANUAL (B-64513EN).
- (e) The gage indicating the current display position in relation to the whole Ladder program is displayed at the right end of the screen.

(2) LADDER diagram

- (a) Nets wider than the screen width are displayed as "Continuous Net" using continuous marks (">A1>"). Same continuous marks mean they are connected with each other.

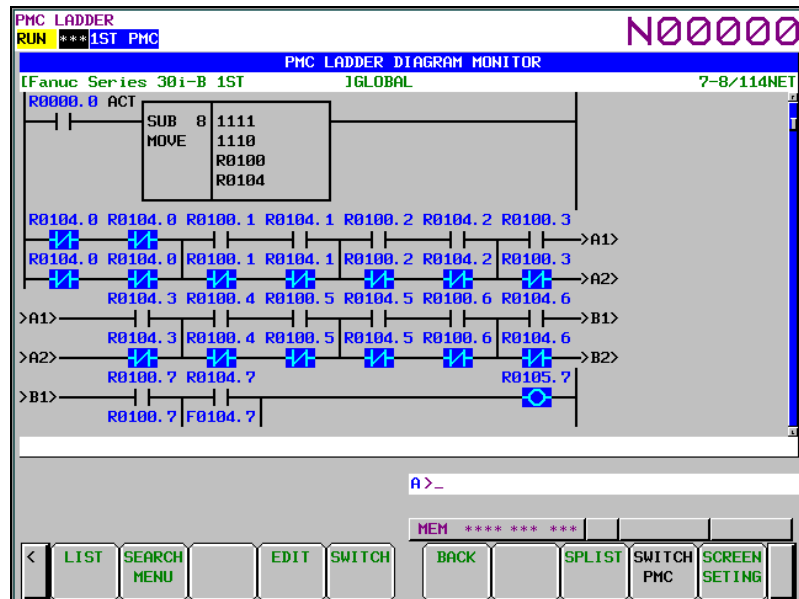
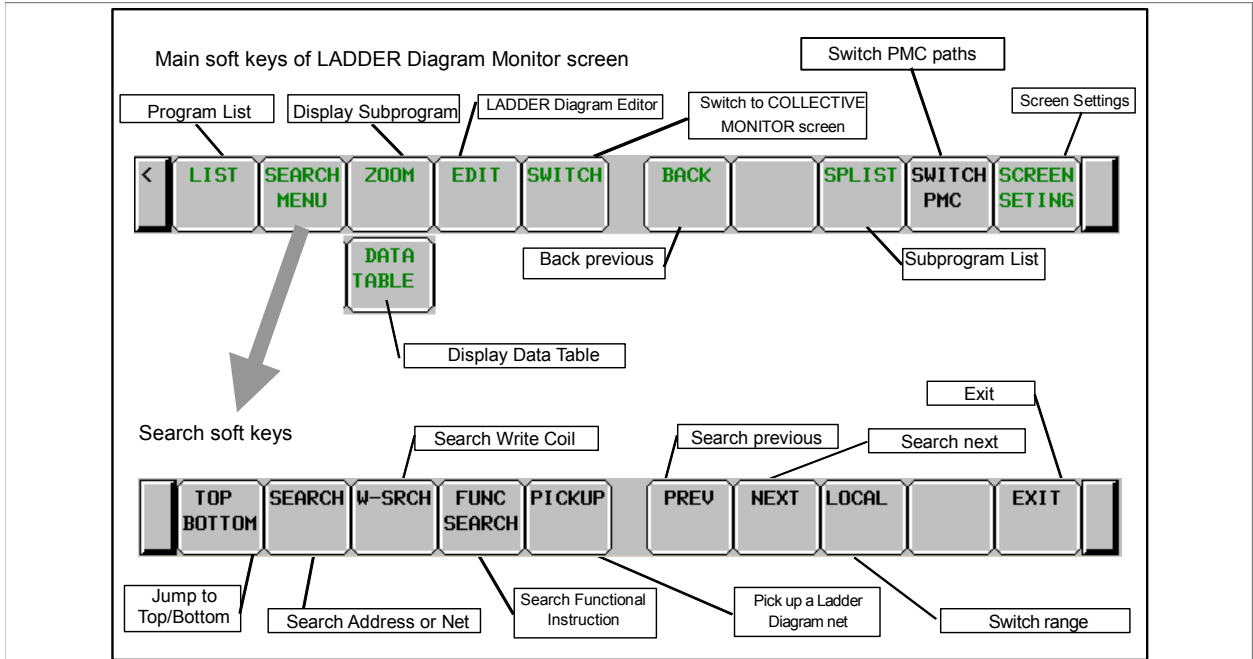

Fig. 6.6.2 (b) Ladder diagram monitor screen

- (3) Monitor
  - (a) Contacts and coils are displayed in different colors according to the status of the signal. The status of power flow is not displayed.
  - (b) Usually, the parameters of functional instructions are monitored and displayed. You can suppress the monitor and display by an appropriate setting. For details, see PMC PROGRAMMING MANUAL (B-64513EN).
- (4) Displaying Symbols and Comments
  - (a) Usually, addresses are displayed above contacts and coils. For an address with a symbol assigned, you can change the setting so that the symbol is displayed instead of the address. You can add colors to addresses. For details, see Subsection “Setting the Display Format of the LADDER DIAGRAM MONITOR Screen” in the PMC PROGRAMMING MANUAL (B-64513EN).
  - (b) If the address of a contact has a comment attached, the comment is displayed below the contact. You can change its display mode by changing the setting. You can add colors to comments. For details, see Subsection “Setting the Display Format of the LADDER DIAGRAM MONITOR Screen” in the PMC PROGRAMMING MANUAL (B-64513EN).
  - (c) If the address used with coil has a comment string assigned, the comment strings will be displayed at the right margin beside the coil. You can use this margin area to display an additional relay instead of the comment string by setting: at this setting, one more relay can be displayed in each diagram line. You can add colors to comments. For details, see Subsection “Setting the Display Format of the LADDER DIAGRAM MONITOR Screen” in the PMC PROGRAMMING MANUAL (B-64513EN).



### 6.6.3 Editing Ladder Programs

At LADDER DIAGRAM EDITOR screen you can edit LADDER program to change its behavior. To switch LADDER DIAGRAM EDITOR screen, press soft key [EDIT] at LADDER DIAGRAM MONITOR screen.

Following operations are available at LADDER DIAGRAM EDITOR screen.

- Delete by net [DELETE]
- Move by net [CUT] & [PASTE]
- Copy by net [COPY] & [PASTE]
- Change address of contacts and coils "bit address" + INPUT key
- Change parameters of functional instructions "number" or "byte address" + INPUT key
- Add new net [CREATE NET]
- Change construction of net [ZOOM]
- Make changes effective [UPDATE]
- Abandon changes [RESTRE]
- Cancel edit [CANCEL EDIT]

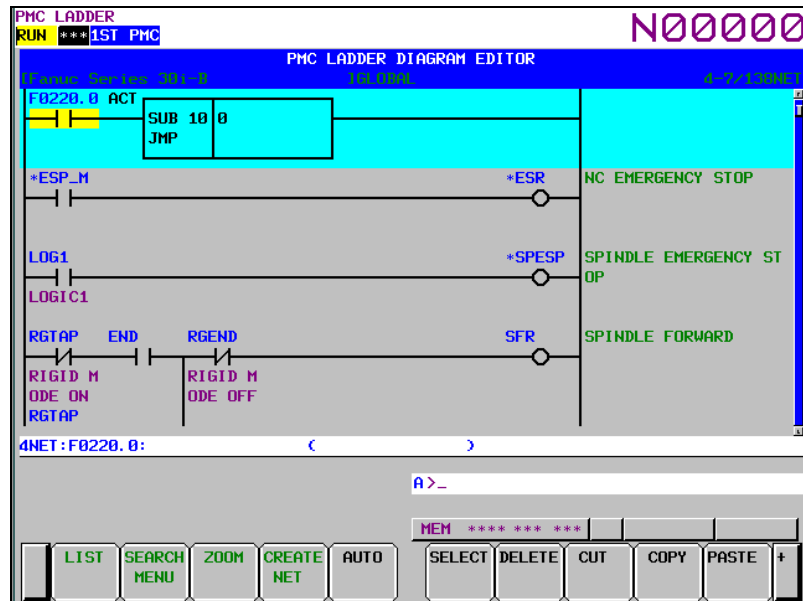

Fig. 6.6.3 (a) Ladder diagram editor screen

### ⚠ CAUTION

- 1 You can edit ladder programs regardless of whether they are active or not. To execute a ladder program with the results of editing being reflected, you must update the ladder program. To do this, click the soft key [UPDATE], or update the program when exiting from the LADDER DIAGRAM EDITOR screen. For details of the method of protecting editing, see "PMC PROGRAMMING MANUAL (B-64513EN)."
- 2 After you have edited a sequence program, the results of editing will be lost if the power is turned off without first writing the edited sequence program to flash ROM.  
Write the sequence program to flash ROM on the I/O screen. If you set "WRITE TO F-ROM(EDIT)" to "YES" on the general functions' setting parameter screen, a confirmation message will be displayed, prompting you to ask whether to write a sequence program to flash ROM after the end of editing. For details of this setting, see "PMC PROGRAMMING MANUAL (B-64513EN)."

- (1) Screen structures
  - (a) It is basically same with LADDER DIAGRAM MONITOR screen, except that no monitor displays of relays and parameters of functional instructions are displayed.
  - (b) At right side of LADDER Diagram area, a position bar is always displayed, which indicates screen position within current subprogram: in LADDER DIAGRAM MONITOR screen, this position bar is exclusively displayed with comments of write coil. Sometimes, this position bar hides a part of write coil comments.
- (2) LADDER Diagram
  - (a) Style of LADDER Diagram is basically same with LADDER DIAGRAM MONITOR screen, except that functional instructions are drawn always in "COMPACT" format that has no monitor displays.
  - (b) Cursor is shown always. And the net, which will be an object of following editing operations, is emphasized in screen.



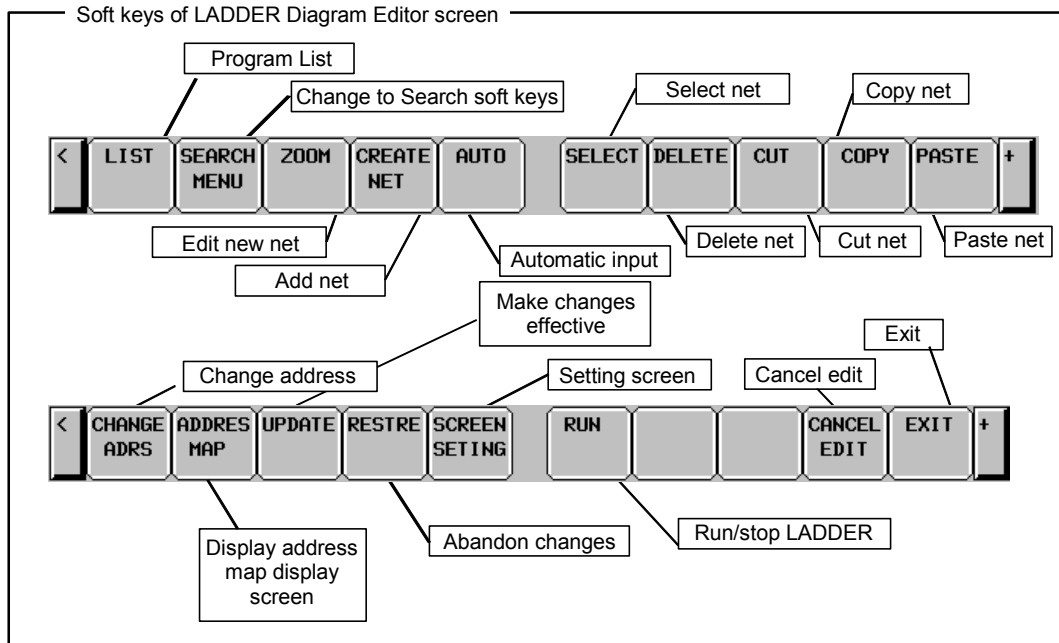

**⚠ WARNING**  
 You have to pay special attention to modify running LADDER program. If you modify LADDER program in wrong way, or update LADDER program with the machine in improper status, it may cause unexpected reaction of the machine. You have to make it sure that modifications you make on LADDER program is appropriate, machine is in proper status, and nobody is near the machine, when you update LADDER program.

### 6.6.3.1 NET EDITOR screen

At NET EDITOR screen, you can create new net, and modify existing net.

- Changing existing nets  
 If you move a net with the soft key [ZOOM], you will enter a mode (Modify mode) in which you can add changes to the net currently indicated by the cursor.
- Adding a new net  
 When soft key [CREATE NET] is used, this screen is in "New mode" to create new net from nothing.

Following operations are available at this screen:

- Place new contacts and coils "bit address" + [—|—], [—○—], etc.
- Change type of contacts and coils [—|—], [—○—], etc.
- Place new functional instructions [FUNC]
- Change type of functional instructions [FUNC]
- Erase contacts, coils, and functional instructions [.....]
- Draw/erase connecting lines [———], [↑———], [———↑]
- Edit data table of functional instructions [DATA TABLE]
- Insert line/column [INSERT LINE], [INSERT COLUMN], [APPEND COLUMN]
- Change address of contacts and coils "bit address" + INPUT key
- Change parameters of functional instructions "number" or "byte address" + INPUT key
- Abandon modifications [CANCEL EDIT]
- Restore the net to the state it was before editing [RESTRE]

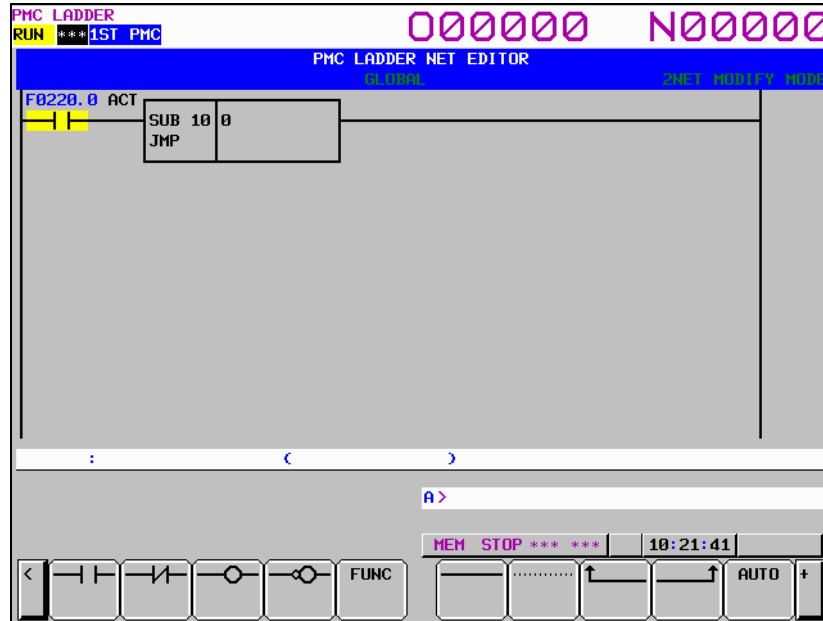
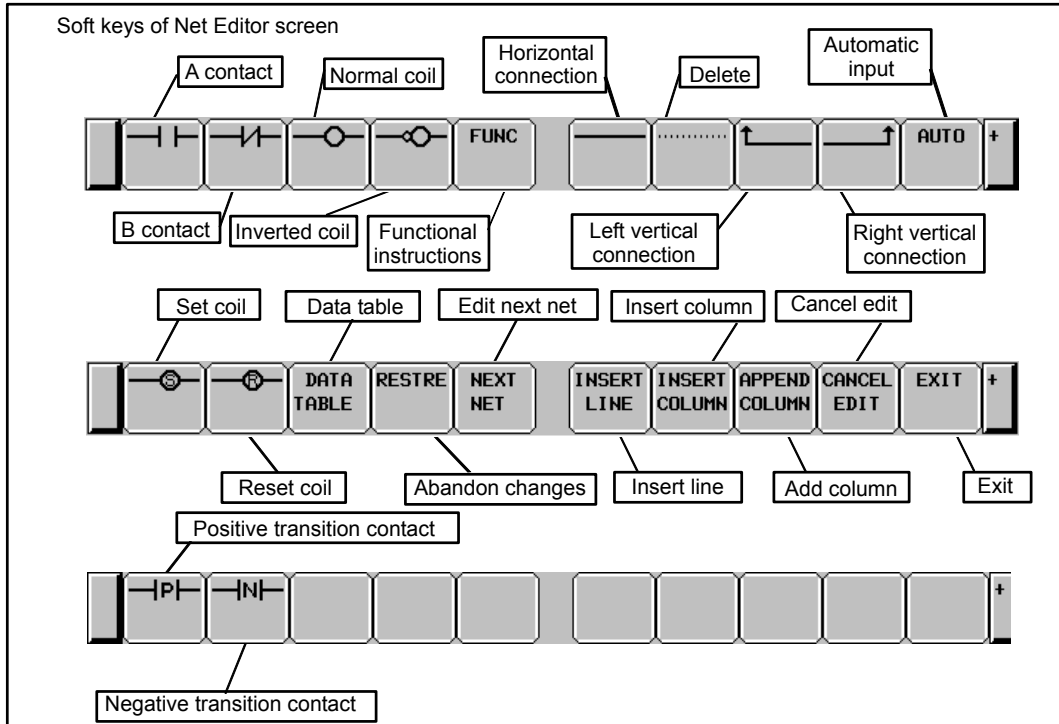

Fig. 6.6.3.1 (a) Structure of the NET EDITOR screen

(1) Screen structures

- (a) It is basically same with LADDER DIAGRAM EDITOR screen, except that only one net is in this screen, and that position bar at right edge of screen does not appear at this screen.
- (b) Current edit mode is indicated at right of the top line as "NEW MODE" or "MODIFY MODE". When soft key [ZOOM] at LADDER DIAGRAM EDITOR screen is used to reach NET EDITOR screen, the screen is in Modify mode, and when soft key [CREATE NET] is used, it is in New mode.
- (c) Current net number is displayed at right of the top line. The net number is same with the net number in previous LADDER DIAGRAM EDITOR screen.
- (d) NET EDITOR screen expands image of net horizontally for a wider net according to its width, while LADDER DIAGRAM MONITOR/EDITOR screen folds nets wider than screen width. When net width is expanded over screen width, attempt to move cursor out of screen will scroll net image to the direction.  
The net of maximum size occupies area of 1024 elements, but actually available area may be little less for internal use according to the internal condition: "element" means the space that is occupied by single relay.



### 6.6.4 PROGRAM LIST EDITOR Screen

At PROGRAM LIST EDITOR screen you can create new program and delete a program in addition to the function of PROGRAM LIST VIEWER screen. To reach this screen, press soft key [LIST] at LADDER DIAGRAM EDITOR screen. Following operations are available at PROGRAM LIST EDITOR screen. For more detail of these operations, see the descriptions of each key to operate.

- Create new program [NEW]
- Delete a program [DELETE]

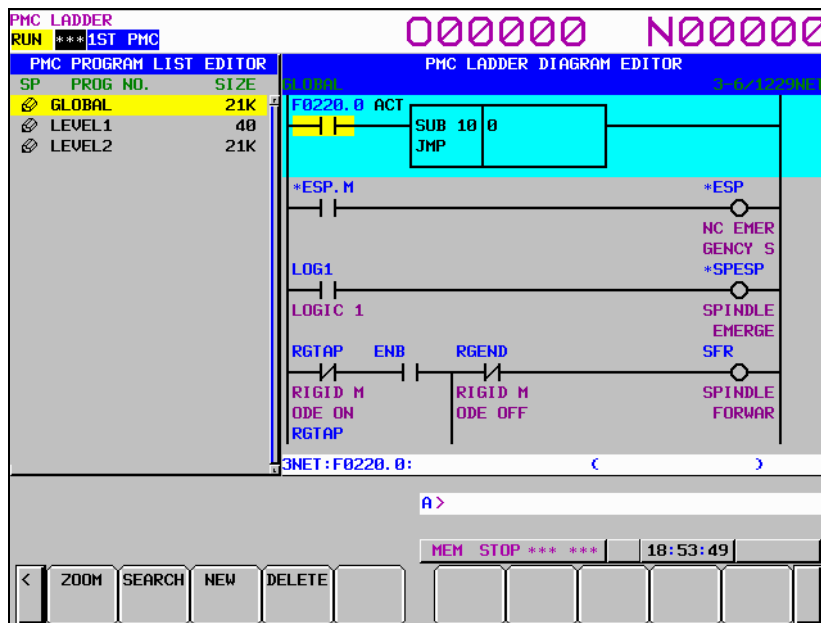
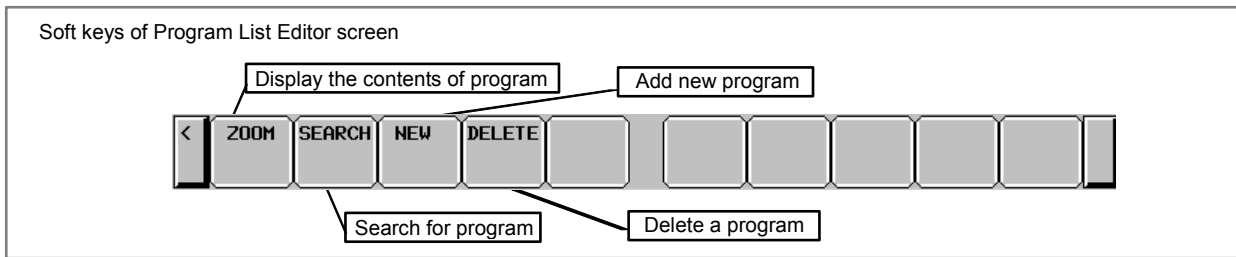

Fig. 6.6.4 PROGRAM LIST EDITOR screen

On the PROGRAM LIST EDITOR screen, a preview of the editor screen for the ladder program currently positioned by the cursor on the program list is displayed on the right of the screen.



### 6.6.5 Collective Monitor Function

The COLLECTIVE MONITOR screen allows you to specify the ladder net containing the coils to be monitored, so that you can monitor only the necessary ladder net.

The COLLECTIVE MONITOR screen can be called in either of the following ways:

- (1) Calling from the PROGRAM LIST VIEWER screen

On the program list screen, move the cursor to the "COLLECT" program position, then click the soft key [ZOOM].

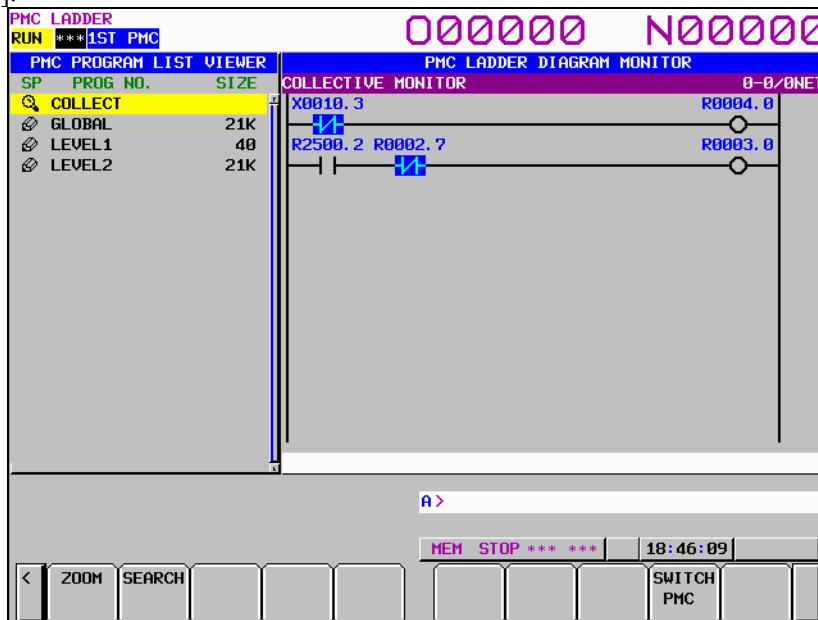

Fig. 6.6.5 (a) PROGRAM LIST VIEWER screen

- (2) Calling from the LADDER DIAGRAM MONITOR screen  
 On the LADDER DIAGRAM MONITOR screen, click the soft key [SWITCH].

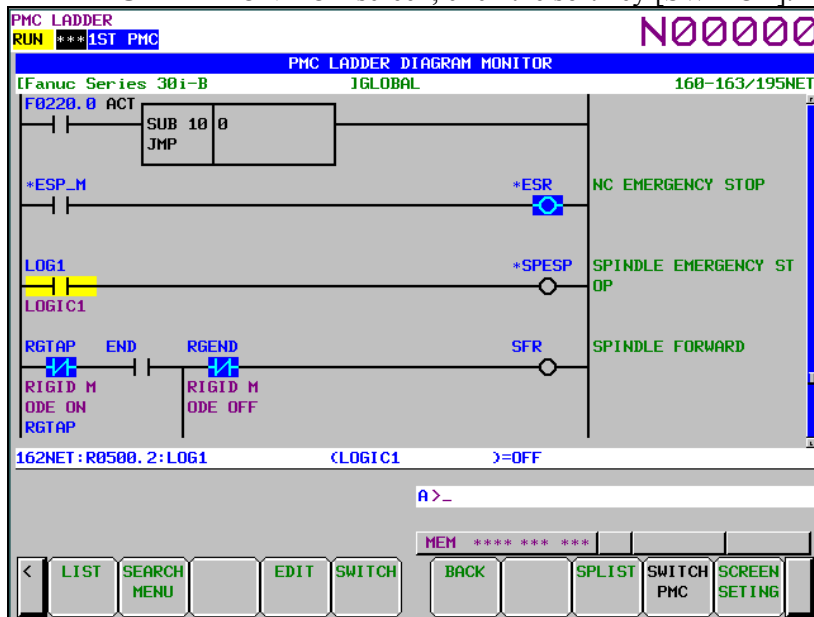

Fig. 6.6.5 (b) LADDER DIAGRAM MONITOR screen

### 6.6.5.1 COLLECTIVE MONITOR function

The COLLECTIVE MONITOR screen is such as that shown Fig. 6.6.5.1 (a). At first, it does not display any ladder diagram. Ladder nets will be added to this screen as they are selected with coil search and pickup operations. Up to 128 nets can be added to the COLLECTIVE MONITOR screen. If an attempt is made to add more, the most recently added 128 nets will be displayed.

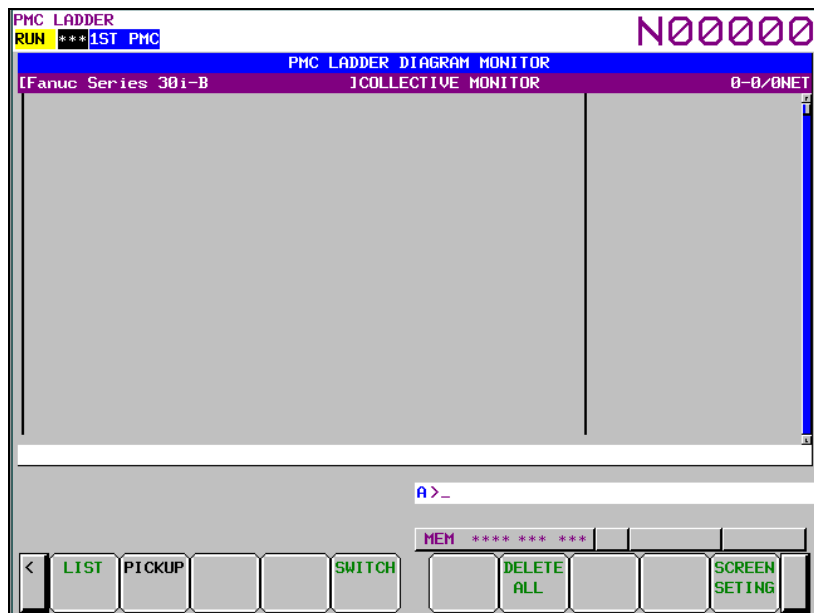

Fig. 6.6.5.1 (a) COLLECTIVE MONITOR screen (initial screen)

## (1) Operations using the soft keys

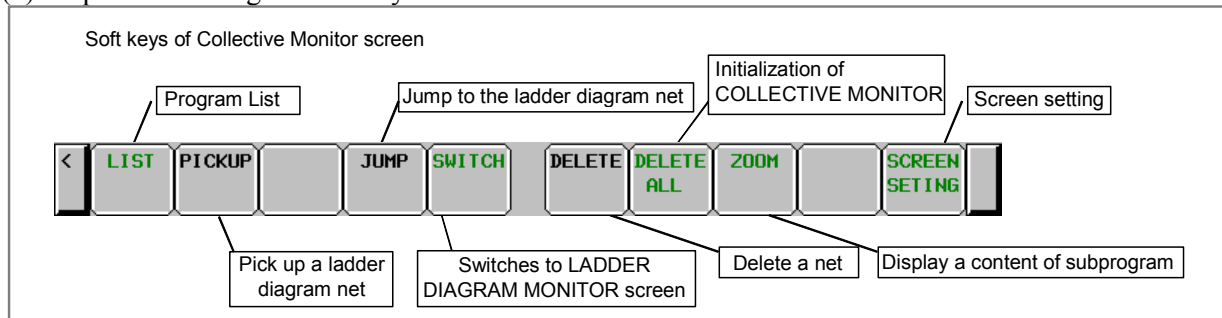

Fig. 6.6.5.1 (b) Soft keys of COLLECTIVE MONITOR screen

## (2) Specifying the ladder diagram to monitor

The operation for picking up ladder nets which you want to monitor on COLLECTIVE MONITOR screen is as follows.

## (a) Specification of ladder nets on COLLECTIVE MONITOR screen

- Specify the address by key input  
Pick up a ladder net by keying in the address used by a coil.
- Indication from a ladder net on the COLLECTIVE MONITOR screen  
Indicate a relay on an already picked up ladder net, with the cursor, to pick up the net that uses the relay address for the coil.

## (b) Specifying a ladder net from the LADDER DIAGRAM MONITOR screen

Specify a net from the LADDER DIAGRAM MONITOR screen to pick it and load it into the COLLECTIVE MONITOR screen.

## (3) Picking up a ladder net on the COLLECTIVE MONITOR screen

You can pick up a ladder net from the COLLECTIVE MONITOR screen. The procedure for picking up a ladder net is as described below.

## (a) Address specification

- (i) Enter the address to monitor (for example, R10.1).
- (ii) Click the [PICKUP] soft key.
- (iii) The net in which a coil uses the address specified in (i) will be picked up and loaded at the beginning of the screen.

## (b) Specification of an address from a ladder net on the screen

- (i) Move the cursor to a relay on the ladder net that uses the address you want to monitor.
- (ii) Click the [PICKUP] soft key.
- (iii) The net in which a coil uses the address specified in (i) will be picked up and loaded at the beginning of the screen, and the cursor moves to the specified coil position.

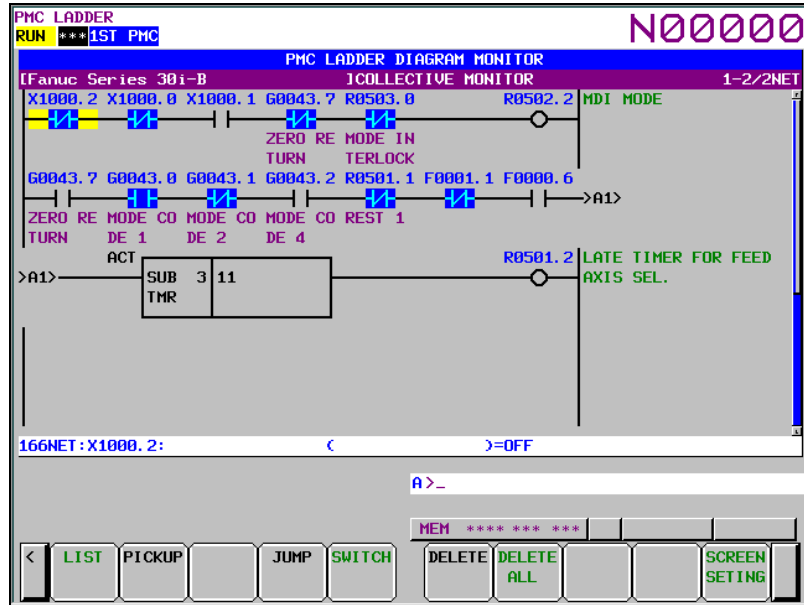

Fig. 6.6.5.1 (c) COLLECTIVE MONITOR screen

- (4) Picking up a ladder net from the LADDER DIAGRAM MONITOR screen  
 You can pick up a ladder net from the LADDER DIAGRAM MONITOR screen. The procedure for picking up a ladder net is as described below.
  - (a) From the LADDER DIAGRAM MONITOR screen, click the soft key [SEARCH] to display the soft keys for search.
  - (b) Move the cursor to the ladder net to pick up.
  - (c) Click the [PICKUP] soft key to pick up and load the net specified in (b) at the beginning of the COLLECTIVE MONITOR screen.
  - (d) For the ladder net picked up and loaded into the COLLECTIVE MONITOR screen, the "P" mark is displayed at the left end of the net.

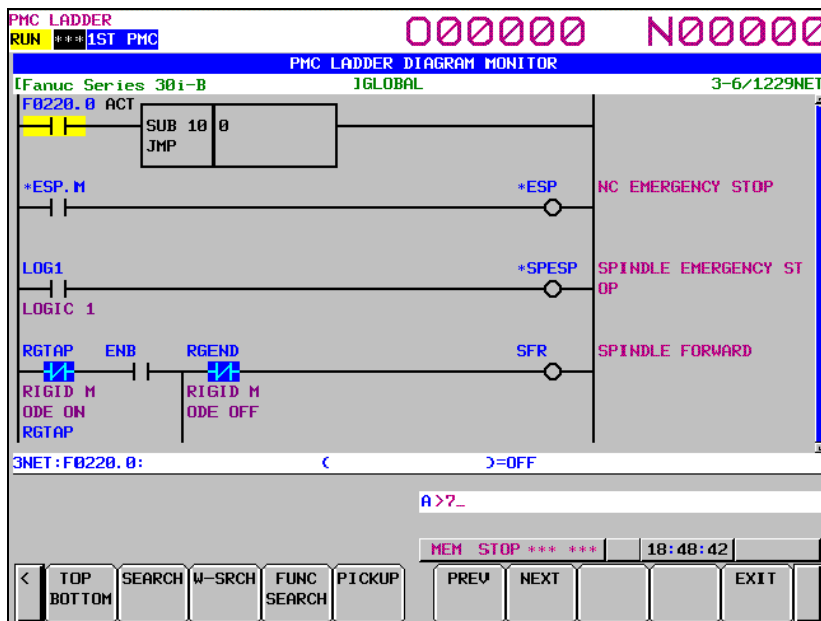
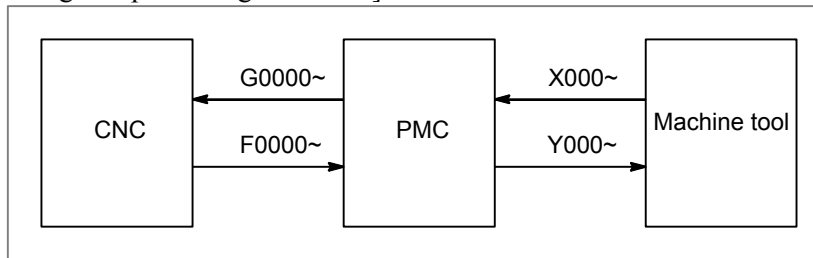

Fig. 6.6.5.1 (d) LADDER DIAGRAM MONITOR screen (search soft keys)

## 6.7 LIST OF ADDRESSES

Interface addresses among CNC and PMC are as follows:

[Example of controlling one path using one PMC]



[Example of controlling three path using one PMC]

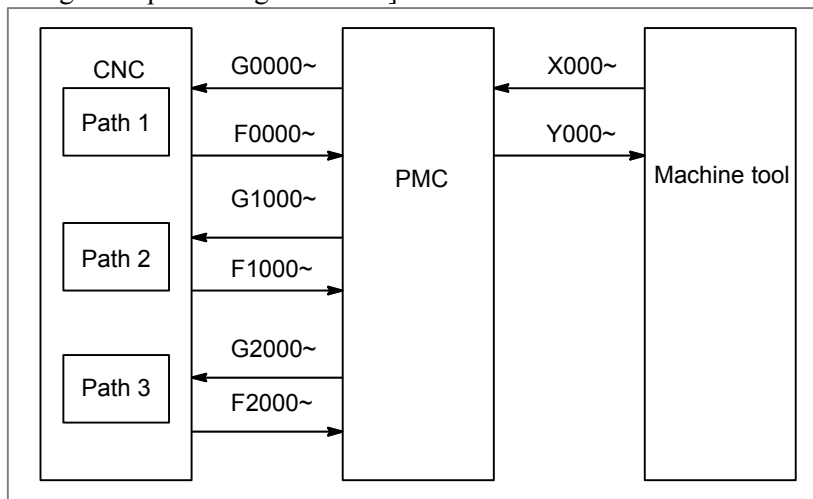



[Example of controlling multi-path CNC using PMC system]

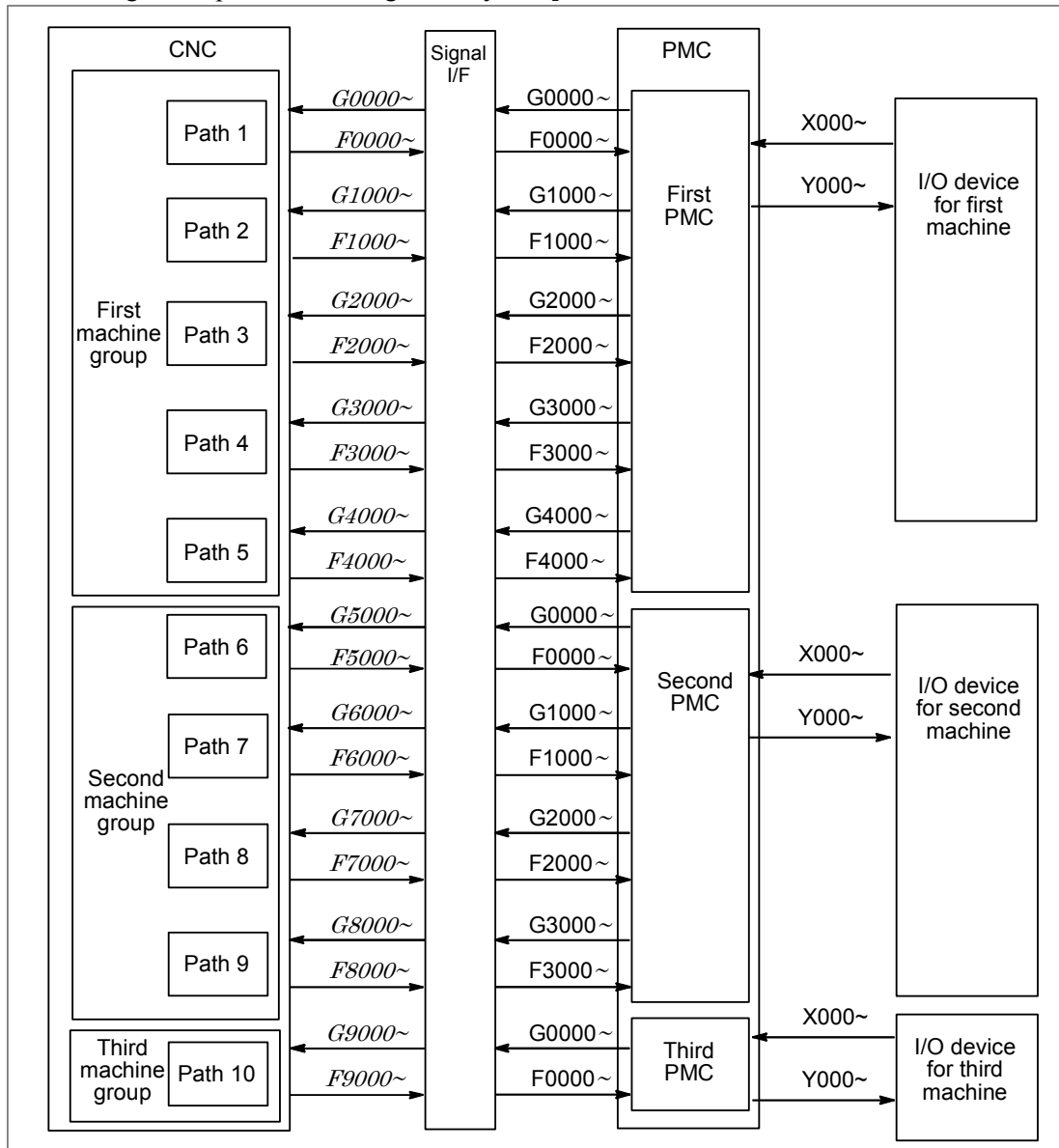

**NOTE**  
 Each PMC of a multi-path PMC system has an independent signal area. The F, G, X, and Y signal addresses of each PMC begin with 0. On the other hand, the F and G signal addresses from the viewpoint of the CNC are fixed for each path number. Note that the F and G signal addresses used in programming of each ladder are different from those from the viewpoint of the CNC.

**Expression of signals**

Address	Symbol (#0 to #7 indicates bit position)							
	#7	#6	#5	#4	#3	#2	#1	#0
F $n$ 000	OP	SA	STL	SPL				RWD

In an item where both lathe system and machining center system are described, some signals are covered with shade ( ) in the signal address figure as shown below. This means either lathe system or machining center system does not have this signal. Upper part is for lathe system and lower part is for machining center system.

	#7	#6	#5	#4	#3	#2	#1	#0	
Gn053	*CDZ		ROVLP		UINT			TMRON	T series M series

[Example 1]

The figure above indicates ROVLP is provided only for the lathe system while the other signals for both the lathe system and machining system.

	#7	#6	#5	#4	#3	#2	#1	#0	
Gn040					OFN9	OFN8	OFN7	OFN6	T series M series

[Example 2]

Signals OFN6 to OFN9 are for machining center system only.

**NOTE**

- 1 In X addresses in the table, the emergency stop signal for each signal is \*ESP<X008.4>, \*ESP<X008.0>, and \*ESP<X008.1>, respectively.
- 2 For multi-path control, one of the following superscripts is attached to the top right of a symbol depending on the signal type.
  - Path type (for path 1 on PMC side) : #1
  - Path type (for path 2 on PMC side) : #2
  - Path type (for path 3 on PMC side) : #3

In addition, #1, #2 or #3 attached to a signal indicates the signal is provided only for path 1, 2, or 3 on PMC side, respectively.

  - Path type : #P
  - Controlled axis type : #SV
  - Spindle type : #SP

In G and F addresses in the table, #P, #SV, or #SP attached to a signal indicates the signal is provided for each path on CNC side, each control axis on CNC side, or each spindle on CNC side, respectively.

  - PMC axis control group type: #PX

#PX attached to a signal indicates the signal is provided for each PMC axis control group.
- 3 For the signals, a single data number is assigned to 8 bits. Each bit has a different meaning.
- 4 The letter "n" in each address representation indicates the address position used in each path on the CNC side, as shown below.
  - 1st path : n=0 (No. 0 to 999)
  - 2nd path : n=1 (No. 1000 to 1999)
  - ⋮
  - 10th path : n=9 (No. 9000 to 9999)
- 5 For a signal of controlled axis type, when the number of axes exceeds eight for each path, set parameter No. 3021 to address this situation.
- 6 For a signal of spindle type, when the number of axes exceeds four for each path, set parameter No. 3022 to address this situation.

MT → CNC

Address	Bit number							
	7	6	5	4	3	2	1	0
X000								
X001								
X002								
X003								
X004 T series	SKIP #1	ESKIP	-MIT2 <sup>#1</sup>	+MIT2 <sup>#1</sup>	-MIT1 <sup>#1</sup>	+MIT1 <sup>#1</sup>	+XAE2 <sup>#1</sup>	+XAE1 <sup>#1</sup>
		SKIP6 #1	SKIP5 #1	SKIP4 #1	SKIP3 #1	SKIP2 #1	SKIP8 #1	SKIP7 #1
X004 M series	SKIP #1	ESKIP				+XAE3 <sup>#1</sup>	+XAE2 <sup>#1</sup>	+XAE1 <sup>#1</sup>
		SKIP6 #1	SKIP5 #1	SKIP4 #1	SKIP3 #1	SKIP2 #1	SKIP8 #1	SKIP7 #1
X005								
X006								
X007	*DEC8 <sup>#2</sup>	*DEC7 <sup>#2</sup>	*DEC6 <sup>#2</sup>	*DEC5 <sup>#2</sup>	*DEC4 <sup>#2</sup>	*DEC3 <sup>#2</sup>	*DEC2 <sup>#2</sup>	*DEC1 <sup>#2</sup>
X008				*ESP			(*ESP)	(*ESP)
X009	*DEC8 <sup>#1</sup>	*DEC7 <sup>#1</sup>	*DEC6 <sup>#1</sup>	*DEC5 <sup>#1</sup>	*DEC4 <sup>#1</sup>	*DEC3 <sup>#1</sup>	*DEC2 <sup>#1</sup>	*DEC1 <sup>#1</sup>
X010	*DEC8 <sup>#3</sup>	*DEC7 <sup>#3</sup>	*DEC6 <sup>#3</sup>	*DEC5 <sup>#3</sup>	*DEC4 <sup>#3</sup>	*DEC3 <sup>#3</sup>	*DEC2 <sup>#3</sup>	*DEC1 <sup>#3</sup>
X011 T series	SKIP #3	ESKIP <sup>#3</sup>	-MIT2 <sup>#3</sup>	+MIT2 <sup>#3</sup>	-MIT1 <sup>#3</sup>	+MIT1 <sup>#3</sup>	+XAE2 <sup>#3</sup>	+XAE1 <sup>#3</sup>
		SKIP6 #3	SKIP5 #3	SKIP4 #3	SKIP3 #3	SKIP2 #3	SKIP8 #3	SKIP7 #3
X011 M series	SKIP #3	ESKIP <sup>#3</sup>				+XAE3 <sup>#3</sup>	+XAE2 <sup>#3</sup>	+XAE1 <sup>#3</sup>
		SKIP6 #3	SKIP5 #3	SKIP4 #3	SKIP3 #3	SKIP2 #3	SKIP8 #3	SKIP7 #3
X012								
X013 T series	SKIP #2	ESKIP <sup>#2</sup>	-MIT2 <sup>#2</sup>	+MIT2 <sup>#2</sup>	-MIT1 <sup>#2</sup>	+MIT1 <sup>#2</sup>	+XAE3 <sup>#2</sup>	+XAE2 <sup>#2</sup>
		SKIP6 #2	SKIP5 #2	SKIP4 #2	SKIP3 #2	SKIP2 #2	SKIP8 #2	SKIP7 #2
X013 M series	SKIP #2	ESKIP <sup>#2</sup>				+XAE3 <sup>#2</sup>	+XAE2 <sup>#2</sup>	+XAE1 <sup>#2</sup>
		SKIP6 #2	SKIP5 #2	SKIP4 #2	SKIP3 #2	SKIP2 #2	SKIP8 #2	SKIP7 #2

PMC → CNC

Address	Bit number							
	7	6	5	4	3	2	1	0
Gn000	ED7 <sup>#P</sup>	ED6 <sup>#P</sup>	ED5 <sup>#P</sup>	ED4 <sup>#P</sup>	ED3 <sup>#P</sup>	ED2 <sup>#P</sup>	ED1 <sup>#P</sup>	ED0 <sup>#P</sup>
Gn001	ED15 <sup>#P</sup>	ED14 <sup>#P</sup>	ED13 <sup>#P</sup>	ED12 <sup>#P</sup>	ED11 <sup>#P</sup>	ED10 <sup>#P</sup>	ED9 <sup>#P</sup>	ED8 <sup>#P</sup>
Gn002	ESTB <sup>#P</sup>	EA6 <sup>#P</sup>	EA5 <sup>#P</sup>	EA4 <sup>#P</sup>	EA3 <sup>#P</sup>	EA2 <sup>#P</sup>	EA1 <sup>#P</sup>	EA0 <sup>#P</sup>
Gn003								
Gn004			MFIN3 <sup>#P</sup>	MFIN2 <sup>#P</sup>	FIN <sup>#P</sup>			
Gn005	BFIN <sup>#P</sup>	AFL <sup>#P</sup>			TFIN <sup>#P</sup>	SFIN <sup>#P</sup>		MFIN <sup>#P</sup>
Gn006		SKIPP <sup>#P</sup>		OVC <sup>#P</sup>		*ABSM <sup>#P</sup>		SRN <sup>#P</sup>
Gn007	RLSOT <sup>#P</sup>	EXLM <sup>#P</sup>	*FLWU <sup>#P</sup>	RLSOT3 <sup>#P</sup>		ST <sup>#P</sup>	STLK <sup>#P</sup>	RVS <sup>#P</sup>
Gn008	ERS <sup>#P</sup>	RRW <sup>#P</sup>	*SP <sup>#P</sup>	*ESP <sup>#P</sup>	*BSL <sup>#P</sup>		*CSL <sup>#P</sup>	*IT <sup>#P</sup>
Gn009				PN16 <sup>#P</sup>	PN8 <sup>#P</sup>	PN4 <sup>#P</sup>	PN2 <sup>#P</sup>	PN1 <sup>#P</sup>
Gn010	*JV7 <sup>#P</sup>	*JV6 <sup>#P</sup>	*JV5 <sup>#P</sup>	*JV4 <sup>#P</sup>	*JV3 <sup>#P</sup>	*JV2 <sup>#P</sup>	*JV1 <sup>#P</sup>	*JV0 <sup>#P</sup>
Gn011	*JV15 <sup>#P</sup>	*JV14 <sup>#P</sup>	*JV13 <sup>#P</sup>	*JV12 <sup>#P</sup>	*JV11 <sup>#P</sup>	*JV10 <sup>#P</sup>	*JV9 <sup>#P</sup>	*JV8 <sup>#P</sup>
Gn012	*FV7 <sup>#P</sup>	*FV6 <sup>#P</sup>	*FV5 <sup>#P</sup>	*FV4 <sup>#P</sup>	*FV3 <sup>#P</sup>	*FV2 <sup>#P</sup>	*FV1 <sup>#P</sup>	*FV0 <sup>#P</sup>
Gn013	*AFV7 <sup>#P</sup>	*AFV6 <sup>#P</sup>	*AFV5 <sup>#P</sup>	*AFV4 <sup>#P</sup>	*AFV3 <sup>#P</sup>	*AFV2 <sup>#P</sup>	*AFV1 <sup>#P</sup>	*AFV0 <sup>#P</sup>
Gn014							ROV2 <sup>#P</sup>	ROV1 <sup>#P</sup>
Gn015								
Gn016	F1D <sup>#P</sup>							
Gn017								
Gn018	HS2D <sup>#P</sup>	HS2C <sup>#P</sup>	HS2B <sup>#P</sup>	HS2A <sup>#P</sup>	HS1D <sup>#P</sup>	HS1C <sup>#P</sup>	HS1B <sup>#P</sup>	HS1A <sup>#P</sup>
Gn019	RT <sup>#P</sup>	MP4 <sup>#P</sup>	MP2 <sup>#P</sup>	MP1 <sup>#P</sup>	HS3D <sup>#P</sup>	HS3C <sup>#P</sup>	HS3B <sup>#P</sup>	HS3A <sup>#P</sup>
Gn020					HS4D <sup>#P</sup>	HS4C <sup>#P</sup>	HS4B <sup>#P</sup>	HS4A <sup>#P</sup>
Gn021	SVR08I <sup>#P</sup>	SVR07I <sup>#P</sup>	SVR06I <sup>#P</sup>	SVR05I <sup>#P</sup>	SVR04I <sup>#P</sup>	SVR03I <sup>#P</sup>	SVR02I <sup>#P</sup>	SVR01I <sup>#P</sup>
Gn022	SVSP <sup>#P</sup>		SVGN <sup>#P</sup>	DFSYC <sup>#P</sup>	SVR12I <sup>#P</sup>	SVR11I <sup>#P</sup>	SVR10I <sup>#P</sup>	SVR09I <sup>#P</sup>

Address	Bit number							
	7	6	5	4	3	2	1	0
Gn023	ALNGH <sup>#P</sup>	RGHTH <sup>#P</sup>	NOINPS <sup>#P</sup>	HREV <sup>#P</sup>	HNDLF <sup>#P</sup>			
Gn024	EPN7 <sup>#P</sup>	EPN6 <sup>#P</sup>	EPN5 <sup>#P</sup>	EPN4 <sup>#P</sup>	EPN3 <sup>#P</sup>	EPN2 <sup>#P</sup>	EPN1 <sup>#P</sup>	EPN0 <sup>#P</sup>
Gn025	EPNS <sup>#P</sup>		EPN13 <sup>#P</sup>	EPN12 <sup>#P</sup>	EPN11 <sup>#P</sup>	EPN10 <sup>#P</sup>	EPN9 <sup>#P</sup>	EPN8 <sup>#P</sup>
Gn026		*SSTP4 <sup>#SP</sup>			SWS4 <sup>#P</sup>		PC4SLC <sup>#P</sup>	PC3SLC <sup>#P</sup>
Gn027	CON <sup>#P</sup>		*SSTP3 <sup>#SP</sup>	*SSTP2 <sup>#SP</sup>	*SSTP1 <sup>#SP</sup>	SWS3 <sup>#P</sup>	SWS2 <sup>#P</sup>	SWS1 <sup>#P</sup>
Gn028	PC2SLC <sup>#P</sup>	SPSTPA <sup>#SP</sup>	*SCPFA <sup>#SP</sup>	*SUCPFA <sup>#SP</sup>		GR2 <sup>#SP</sup>	GR1 <sup>#SP</sup>	
Gn029		*SSTP <sup>#P</sup>	SOR <sup>#P</sup>	SAR <sup>#P</sup>	GR32 <sup>#SP</sup>	GR31 <sup>#SP</sup>	GR22 <sup>#SP</sup>	GR21 <sup>#SP</sup>
Gn030	SOV7 <sup>#P</sup>	SOV6 <sup>#P</sup>	SOV5 <sup>#P</sup>	SOV4 <sup>#P</sup>	SOV3 <sup>#P</sup>	SOV2 <sup>#P</sup>	SOV1 <sup>#P</sup>	SOV0 <sup>#P</sup>
Gn031	PKESS2 <sup>#P</sup>	PKESS1 <sup>#P</sup>	GR42 <sup>#SP</sup>	GR41 <sup>#SP</sup>	M3R <sup>#P</sup>			
Gn032	R08I <sup>#SP</sup>	R07I <sup>#SP</sup>	R06I <sup>#SP</sup>	R05I <sup>#SP</sup>	R04I <sup>#SP</sup>	R03I <sup>#SP</sup>	R02I <sup>#SP</sup>	R01I <sup>#SP</sup>
Gn033	SIND <sup>#SP</sup>	SSIN <sup>#SP</sup>	SGN <sup>#SP</sup>		R12I <sup>#SP</sup>	R11I <sup>#SP</sup>	R10I <sup>#SP</sup>	R09I <sup>#SP</sup>
Gn034	R08I2 <sup>#SP</sup>	R07I2 <sup>#SP</sup>	R06I2 <sup>#SP</sup>	R05I2 <sup>#SP</sup>	R04I2 <sup>#SP</sup>	R03I2 <sup>#SP</sup>	R02I2 <sup>#SP</sup>	R01I2 <sup>#SP</sup>
Gn035	SIND2 <sup>#SP</sup>	SSIN2 <sup>#SP</sup>	SGN2 <sup>#SP</sup>		R12I2 <sup>#SP</sup>	R11I2 <sup>#SP</sup>	R10I2 <sup>#SP</sup>	R09I2 <sup>#SP</sup>
Gn036	R08I3 <sup>#SP</sup>	R07I3 <sup>#SP</sup>	R06I3 <sup>#SP</sup>	R05I3 <sup>#SP</sup>	R04I3 <sup>#SP</sup>	R03I3 <sup>#SP</sup>	R02I3 <sup>#SP</sup>	R01I3 <sup>#SP</sup>
Gn037	SIND3 <sup>#SP</sup>	SSIN3 <sup>#SP</sup>	SGN3 <sup>#SP</sup>		R12I3 <sup>#SP</sup>	R11I3 <sup>#SP</sup>	R10I3 <sup>#SP</sup>	R09I3 <sup>#SP</sup>
Gn038	*BECLP <sup>#P</sup>	*BEUCP <sup>#P</sup>	SDPC <sup>#P</sup>		SPPHS <sup>#P</sup>	SPSYC <sup>#P</sup>	SBRT <sup>#P</sup>	*PLSST <sup>#P</sup>
Gn039	GOQSM <sup>#P</sup> GOQSM <sup>#P</sup>	WOQSM <sup>#P</sup> WOQSM <sup>#P</sup>	OFN5 <sup>#P</sup> OFN5 <sup>#P</sup>	OFN4 <sup>#P</sup> OFN4 <sup>#P</sup>	OFN3 <sup>#P</sup> OFN3 <sup>#P</sup>	OFN2 <sup>#P</sup> OFN2 <sup>#P</sup>	OFN1 <sup>#P</sup> OFN1 <sup>#P</sup>	OFN0 <sup>#P</sup> OFN0 <sup>#P</sup>
Gn040	WOSET <sup>#P</sup>	PRC <sup>#P</sup>	S2TLS <sup>#P</sup>		OFN9 <sup>#P</sup> OFN9 <sup>#P</sup>	OFN8 <sup>#P</sup> OFN8 <sup>#P</sup>	OFN7 <sup>#P</sup> OFN7 <sup>#P</sup>	OFN6 <sup>#P</sup> OFN6 <sup>#P</sup>
Gn041	HS2ID <sup>#P</sup>	HS2IC <sup>#P</sup>	HS2IB <sup>#P</sup>	HS2IA <sup>#P</sup>	HS1ID <sup>#P</sup>	HS1IC <sup>#P</sup>	HS1IB <sup>#P</sup>	HS1IA <sup>#P</sup>
Gn042	DMMC <sup>#P</sup>				HS3ID <sup>#P</sup>	HS3IC <sup>#P</sup>	HS3IB <sup>#P</sup>	HS3IA <sup>#P</sup>
Gn043	ZRN <sup>#P</sup>		DNCI <sup>#P</sup>			MD4 <sup>#P</sup>	MD2 <sup>#P</sup>	MD1 <sup>#P</sup>
Gn044							MLK <sup>#P</sup>	BDT1 <sup>#P</sup>
Gn045	BDT9 <sup>#P</sup>	BDT8 <sup>#P</sup>	BDT7 <sup>#P</sup>	BDT6 <sup>#P</sup>	BDT5 <sup>#P</sup>	BDT4 <sup>#P</sup>	BDT3 <sup>#P</sup>	BDT2 <sup>#P</sup>
Gn046	DRN <sup>#P</sup>	KEY4	KEY3	KEY2	KEY1		SBK <sup>#P</sup>	KEYP

Address	Bit number							
	7	6	5	4	3	2	1	0
Gn047	TL128 <sup>#P</sup>	TL64 <sup>#P</sup>	TL32 <sup>#P</sup>	TL16 <sup>#P</sup>	TL08 <sup>#P</sup>	TL04 <sup>#P</sup>	TL02 <sup>#P</sup>	TL01 <sup>#P</sup>
Gn048	TLRST <sup>#P</sup>	TLRSTI <sup>#P</sup>	TLSKP <sup>#P</sup>			LFCIV <sup>#P</sup>	TL512 <sup>#P</sup>	TL256 <sup>#P</sup>
Gn049	*TLV7 <sup>#P</sup>	*TLV6 <sup>#P</sup>	*TLV5 <sup>#P</sup>	*TLV4 <sup>#P</sup>	*TLV3 <sup>#P</sup>	*TLV2 <sup>#P</sup>	*TLV1 <sup>#P</sup>	*TLV0 <sup>#P</sup>
Gn050							*TLV9 <sup>#P</sup>	*TLV8 <sup>#P</sup>
Gn051	*CHLD <sup>#P</sup>	CHPST <sup>#P</sup>			*CHP8 <sup>#P</sup>	*CHP4 <sup>#P</sup>	*CHP2 <sup>#P</sup>	*CHP1 <sup>#P</sup>
Gn052								
Gn053	*CDZ <sup>#P</sup>	SMZ <sup>#P</sup>	ROVLP <sup>#P</sup>		UINT <sup>#P</sup>			TMRON <sup>#P</sup>
Gn054	UI007 <sup>#P</sup>	UI006 <sup>#P</sup>	UI005 <sup>#P</sup>	UI004 <sup>#P</sup>	UI003 <sup>#P</sup>	UI002 <sup>#P</sup>	UI001 <sup>#P</sup>	UI000 <sup>#P</sup>
Gn055	UI015 <sup>#P</sup>	UI014 <sup>#P</sup>	UI013 <sup>#P</sup>	UI012 <sup>#P</sup>	UI011 <sup>#P</sup>	UI010 <sup>#P</sup>	UI009 <sup>#P</sup>	UI008 <sup>#P</sup>
Gn056	UI023 <sup>#P</sup>	UI022 <sup>#P</sup>	UI021 <sup>#P</sup>	UI020 <sup>#P</sup>	UI019 <sup>#P</sup>	UI018 <sup>#P</sup>	UI017 <sup>#P</sup>	UI016 <sup>#P</sup>
Gn057	UI031 <sup>#P</sup>	UI030 <sup>#P</sup>	UI029 <sup>#P</sup>	UI028 <sup>#P</sup>	UI027 <sup>#P</sup>	UI026 <sup>#P</sup>	UI025 <sup>#P</sup>	UI024 <sup>#P</sup>
Gn058					EXWT	EXSTP	EXRD	
Gn059	NSYNCA <sup>#P</sup>						TRRTN <sup>#P</sup>	TRESC <sup>#P</sup>
Gn060	*TSB <sup>#P</sup>							
Gn061	RGTS4 <sup>#SP</sup>	RGTS3 <sup>#SP</sup>	RGTS2 <sup>#SP</sup>	RGTS1 <sup>#SP</sup>		SYSS <sup>#P</sup>		RGTA <sup>#P</sup>
Gn062	HEAD2	RTNT <sup>#P</sup>						
Gn063	NMWT <sup>#P</sup>	INFD <sup>#P</sup>	NOZAGC <sup>#P</sup>		SLSPB <sup>#P</sup>	SLSPA <sup>#P</sup>	NOWT	HEAD
Gn064		ESRSYC <sup>#P</sup>			SLPCB <sup>#P</sup>	SLSPA <sup>#P</sup>		
Gn065	HCSK4 <sup>#P</sup>	HCSK3 <sup>#P</sup>	HCSK2 <sup>#P</sup>	HCSK1 <sup>#P</sup>	HSRT <sup>#P</sup>			
Gn066	EKSET			RTRCT <sup>#P</sup>			ENBKY	IGNVRY <sup>#P</sup>
Gn067	HCREQ	HCABT			MCHK <sup>#P</sup>	MMOD <sup>#P</sup>	CGREN <sup>#P</sup>	MLTC <sup>#P</sup>
Gn068	MTL07 <sup>#P</sup>	MTL06 <sup>#P</sup>	MTL05 <sup>#P</sup>	MTL04 <sup>#P</sup>	MTL03 <sup>#P</sup>	MTL02 <sup>#P</sup>	MTL01 <sup>#P</sup>	MTL00 <sup>#P</sup>
Gn069	MTL15 <sup>#P</sup>	MTL14 <sup>#P</sup>	MTL13 <sup>#P</sup>	MTL12 <sup>#P</sup>	MTL11 <sup>#P</sup>	MTL10 <sup>#P</sup>	MTL09 <sup>#P</sup>	MTL08 <sup>#P</sup>
Gn070	MRDYA <sup>#SP</sup>	ORCMA <sup>#SP</sup>	SFRA <sup>#SP</sup>	SRVA <sup>#SP</sup>	CTH1A <sup>#SP</sup>	CTH2A <sup>#SP</sup>	TLMHA <sup>#SP</sup>	TLMLA <sup>#SP</sup>

Address	Bit number							
	7	6	5	4	3	2	1	0
Gn071	RCHA <sup>#SP</sup>	RSLA <sup>#SP</sup>	INTGA <sup>#SP</sup>	SOCNA <sup>#SP</sup>	MCFNA <sup>#SP</sup>	SPSLA <sup>#SP</sup>	*ESPA <sup>#SP</sup>	ARSTA <sup>#SP</sup>
Gn072	RCHHGA <sup>#SP</sup>	MFNHGA <sup>#SP</sup>	INCMDA <sup>#SP</sup>	OVRI <sup>#SP</sup>	DEFMDA <sup>#SP</sup>	NRROA <sup>#SP</sup>	ROTA <sup>#SP</sup>	INDXA <sup>#SP</sup>
Gn073						MPOFA <sup>#SP</sup>	SLVA <sup>#SP</sup>	MORCMA <sup>#SP</sup>
Gn074	MRDYB <sup>#SP</sup>	ORCMB <sup>#SP</sup>	SFRB <sup>#SP</sup>	SRVB <sup>#SP</sup>	CTH1B <sup>#SP</sup>	CTH2B <sup>#SP</sup>	TLMHB <sup>#SP</sup>	TLMLB <sup>#SP</sup>
Gn075	RCHB <sup>#SP</sup>	RSLB <sup>#SP</sup>	INTGB <sup>#SP</sup>	SOCNB <sup>#SP</sup>	MCFNB <sup>#SP</sup>	SPSLB <sup>#SP</sup>	*ESPB <sup>#SP</sup>	ARSTB <sup>#SP</sup>
Gn076	RCHHGB <sup>#SP</sup>	MFNHGB <sup>#SP</sup>	INCMDB <sup>#SP</sup>	OVRI <sup>#SP</sup>	DEFMDB <sup>#SP</sup>	NRROB <sup>#SP</sup>	ROTAB <sup>#SP</sup>	INDXB <sup>#SP</sup>
Gn077						MPOFB <sup>#SP</sup>	SLVB <sup>#SP</sup>	MORCMB <sup>#SP</sup>
Gn078	SH07A <sup>#SP</sup>	SH06A <sup>#SP</sup>	SH05A <sup>#SP</sup>	SH04A <sup>#SP</sup>	SH03A <sup>#SP</sup>	SH02A <sup>#SP</sup>	SH01A <sup>#SP</sup>	SH00A <sup>#SP</sup>
Gn079					SH11A <sup>#SP</sup>	SH10A <sup>#SP</sup>	SH09A <sup>#SP</sup>	SH08A <sup>#SP</sup>
Gn080	SH07B <sup>#SP</sup>	SH06B <sup>#SP</sup>	SH05B <sup>#SP</sup>	SH04B <sup>#SP</sup>	SH03B <sup>#SP</sup>	SH02B <sup>#SP</sup>	SH01B <sup>#SP</sup>	SH00B <sup>#SP</sup>
Gn081					SH11B <sup>#SP</sup>	SH10B <sup>#SP</sup>	SH09B <sup>#SP</sup>	SH08B <sup>#SP</sup>
Gn082	EUI07 <sup>#P</sup>	EUI06 <sup>#P</sup>	EUI05 <sup>#P</sup>	EUI04 <sup>#P</sup>	EUI03 <sup>#P</sup>	EUI02 <sup>#P</sup>	EUI01 <sup>#P</sup>	EUI00 <sup>#P</sup>
Gn083	EUI15 <sup>#P</sup>	EUI14 <sup>#P</sup>	EUI13 <sup>#P</sup>	EUI12 <sup>#P</sup>	EUI11 <sup>#P</sup>	EUI10 <sup>#P</sup>	EUI09 <sup>#P</sup>	EUI08 <sup>#P</sup>
Gn084								
Gn085								
Gn086					-Ja <sup>#P</sup>	+Ja <sup>#P</sup>	-Jg <sup>#P</sup>	+Jg <sup>#P</sup>
Gn087	MP42 <sup>#P</sup>	MP41 <sup>#P</sup>		MP32 <sup>#P</sup>	MP31 <sup>#P</sup>		MP22 <sup>#P</sup>	MP21 <sup>#P</sup>
Gn088	HS4ID <sup>#P</sup>	HS4IC <sup>#P</sup>	HS4IB <sup>#P</sup>	HS4IA <sup>#P</sup>				
Gn089								
Gn090	G2SLC <sup>#P</sup>	G2Y <sup>#P</sup>	G2Z <sup>#P</sup>	G2X <sup>#P</sup>		G2RVY <sup>#P</sup>	G2RVZ <sup>#P</sup>	G2RVX <sup>#P</sup>
Gn091								
Gn092								
Gn093								
Gn094								

Address	Bit number							
	7	6	5	4	3	2	1	0
Gn095								
Gn096	HROV <sup>#P</sup>	*HROV6 <sup>#P</sup>	*HROV5 <sup>#P</sup>	*HROV4 <sup>#P</sup>	*HROV3 <sup>#P</sup>	*HROV2 <sup>#P</sup>	*HROV1 <sup>#P</sup>	*HROV0 <sup>#P</sup>
Gn097								
Gn098	EKC7	EKC6	EKC5	EKC4	EKC3	EKC2	EKC1	EKC0
Gn099								
Gn100	+J8 <sup>#SV</sup>	+J7 <sup>#SV</sup>	+J6 <sup>#SV</sup>	+J5 <sup>#SV</sup>	+J4 <sup>#SV</sup>	+J3 <sup>#SV</sup>	+J2 <sup>#SV</sup>	+J1 <sup>#SV</sup>
Gn101	*+ED28 <sup>#SV</sup>	*+ED27 <sup>#SV</sup>	*+ED26 <sup>#SV</sup>	*+ED25 <sup>#SV</sup>	*+ED24 <sup>#SV</sup>	*+ED23 <sup>#SV</sup>	*+ED22 <sup>#SV</sup>	*+ED21 <sup>#SV</sup>
Gn102	-J8 <sup>#SV</sup>	-J7 <sup>#SV</sup>	-J6 <sup>#SV</sup>	-J5 <sup>#SV</sup>	-J4 <sup>#SV</sup>	-J3 <sup>#SV</sup>	-J2 <sup>#SV</sup>	-J1 <sup>#SV</sup>
Gn103	*-ED28 <sup>#SV</sup>	*-ED27 <sup>#SV</sup>	*-ED26 <sup>#SV</sup>	*-ED25 <sup>#SV</sup>	*-ED24 <sup>#SV</sup>	*-ED23 <sup>#SV</sup>	*-ED22 <sup>#SV</sup>	*-ED21 <sup>#SV</sup>
Gn104	+EXL8 <sup>#SV</sup>	+EXL7 <sup>#SV</sup>	+EXL6 <sup>#SV</sup>	+EXL5 <sup>#SV</sup>	+EXL4 <sup>#SV</sup>	+EXL3 <sup>#SV</sup>	+EXL2 <sup>#SV</sup>	+EXL1 <sup>#SV</sup>
Gn105	-EXL8 <sup>#SV</sup>	-EXL7 <sup>#SV</sup>	-EXL6 <sup>#SV</sup>	-EXL5 <sup>#SV</sup>	-EXL4 <sup>#SV</sup>	-EXL3 <sup>#SV</sup>	-EXL2 <sup>#SV</sup>	-EXL1 <sup>#SV</sup>
Gn106	MI8 <sup>#SV</sup>	MI7 <sup>#SV</sup>	MI6 <sup>#SV</sup>	MI5 <sup>#SV</sup>	MI4 <sup>#SV</sup>	MI3 <sup>#SV</sup>	MI2 <sup>#SV</sup>	MI1 <sup>#SV</sup>
Gn107	*+ED38 <sup>#SV</sup>	*+ED37 <sup>#SV</sup>	*+ED36 <sup>#SV</sup>	*+ED35 <sup>#SV</sup>	*+ED34 <sup>#SV</sup>	*+ED33 <sup>#SV</sup>	*+ED32 <sup>#SV</sup>	*+ED31 <sup>#SV</sup>
Gn108	MLK8 <sup>#SV</sup>	MLK7 <sup>#SV</sup>	MLK6 <sup>#SV</sup>	MLK5 <sup>#SV</sup>	MLK4 <sup>#SV</sup>	MLK3 <sup>#SV</sup>	MLK2 <sup>#SV</sup>	MLK1 <sup>#SV</sup>
Gn109	*-ED38 <sup>#SV</sup>	*-ED37 <sup>#SV</sup>	*-ED36 <sup>#SV</sup>	*-ED35 <sup>#SV</sup>	*-ED34 <sup>#SV</sup>	*-ED33 <sup>#SV</sup>	*-ED32 <sup>#SV</sup>	*-ED31 <sup>#SV</sup>
Gn110	+LM8 <sup>#SV</sup>	+LM7 <sup>#SV</sup>	+LM6 <sup>#SV</sup>	+LM5 <sup>#SV</sup>	+LM4 <sup>#SV</sup>	+LM3 <sup>#SV</sup>	+LM2 <sup>#SV</sup>	+LM1 <sup>#SV</sup>
Gn111								
Gn112	-LM8 <sup>#SV</sup>	-LM7 <sup>#SV</sup>	-LM6 <sup>#SV</sup>	-LM5 <sup>#SV</sup>	-LM4 <sup>#SV</sup>	-LM3 <sup>#SV</sup>	-LM2 <sup>#SV</sup>	-LM1 <sup>#SV</sup>
Gn113								
Gn114	*+L8 <sup>#SV</sup>	*+L7 <sup>#SV</sup>	*+L6 <sup>#SV</sup>	*+L5 <sup>#SV</sup>	*+L4 <sup>#SV</sup>	*+L3 <sup>#SV</sup>	*+L2 <sup>#SV</sup>	*+L1 <sup>#SV</sup>
Gn115								
Gn116	*-L8 <sup>#SV</sup>	*-L7 <sup>#SV</sup>	*-L6 <sup>#SV</sup>	*-L5 <sup>#SV</sup>	*-L4 <sup>#SV</sup>	*-L3 <sup>#SV</sup>	*-L2 <sup>#SV</sup>	*-L1 <sup>#SV</sup>
Gn117								
Gn118	*+ED8 <sup>#SV</sup>	*+ED7 <sup>#SV</sup>	*+ED6 <sup>#SV</sup>	*+ED5 <sup>#SV</sup>	*+ED4 <sup>#SV</sup>	*+ED3 <sup>#SV</sup>	*+ED2 <sup>#SV</sup>	*+ED1 <sup>#SV</sup>



Address	Bit number							
	7	6	5	4	3	2	1	0
Gn119								
Gn120	*-ED8 <sup>#SV</sup>	*-ED7 <sup>#SV</sup>	*-ED6 <sup>#SV</sup>	*-ED5 <sup>#SV</sup>	*-ED4 <sup>#SV</sup>	*-ED3 <sup>#SV</sup>	*-ED2 <sup>#SV</sup>	*-ED1 <sup>#SV</sup>
Gn121								
Gn122	PK8 <sup>#SV</sup>	PK7 <sup>#SV</sup>	PK6 <sup>#SV</sup>	PK5 <sup>#SV</sup>	PK4 <sup>#SV</sup>	PK3 <sup>#SV</sup>	PK2 <sup>#SV</sup>	PK1 <sup>#SV</sup>
	PKES2 <sup>#P</sup>	PKES1 <sup>#P</sup>						
Gn123								
Gn124	DTCH8 <sup>#SV</sup>	DTCH7 <sup>#SV</sup>	DTCH6 <sup>#SV</sup>	DTCH5 <sup>#SV</sup>	DTCH4 <sup>#SV</sup>	DTCH3 <sup>#SV</sup>	DTCH2 <sup>#SV</sup>	DTCH1 <sup>#SV</sup>
Gn125	IUDD8 <sup>#SV</sup>	IUDD7 <sup>#SV</sup>	IUDD6 <sup>#SV</sup>	IUDD5 <sup>#SV</sup>	IUDD4 <sup>#SV</sup>	IUDD3 <sup>#SV</sup>	IUDD2 <sup>#SV</sup>	IUDD1 <sup>#SV</sup>
Gn126	SVF8 <sup>#SV</sup>	SVF7 <sup>#SV</sup>	SVF6 <sup>#SV</sup>	SVF5 <sup>#SV</sup>	SVF4 <sup>#SV</sup>	SVF3 <sup>#SV</sup>	SVF2 <sup>#SV</sup>	SVF1 <sup>#SV</sup>
Gn127								
Gn128	MIX8 <sup>#SV</sup>	MIX7 <sup>#SV</sup>	MIX6 <sup>#SV</sup>	MIX5 <sup>#SV</sup>	MIX4 <sup>#SV</sup>	MIX3 <sup>#SV</sup>	MIX2 <sup>#SV</sup>	MIX1 <sup>#SV</sup>
Gn129								
Gn130	*IT8 <sup>#SV</sup>	*IT7 <sup>#SV</sup>	*IT6 <sup>#SV</sup>	*IT5 <sup>#SV</sup>	*IT4 <sup>#SV</sup>	*IT3 <sup>#SV</sup>	*IT2 <sup>#SV</sup>	*IT1 <sup>#SV</sup>
Gn131								
Gn132	+MIT8 <sup>#P</sup>	+MIT7 <sup>#P</sup>	+MIT6 <sup>#P</sup>	+MIT5 <sup>#P</sup>	+MIT4 <sup>#P</sup>	+MIT3 <sup>#P</sup>	+MIT2 <sup>#P</sup>	+MIT1 <sup>#P</sup>
Gn133								
Gn134	-MIT8 <sup>#P</sup>	-MIT7 <sup>#P</sup>	-MIT6 <sup>#P</sup>	-MIT5 <sup>#P</sup>	-MIT4 <sup>#P</sup>	-MIT3 <sup>#P</sup>	-MIT2 <sup>#P</sup>	-MIT1 <sup>#P</sup>
Gn135								
Gn136	EAX8 <sup>#SV</sup>	EAX7 <sup>#SV</sup>	EAX6 <sup>#SV</sup>	EAX5 <sup>#SV</sup>	EAX4 <sup>#SV</sup>	EAX3 <sup>#SV</sup>	EAX2 <sup>#SV</sup>	EAX1 <sup>#SV</sup>
Gn137								
Gn138	SYNC8 <sup>#SV</sup>	SYNC7 <sup>#SV</sup>	SYNC6 <sup>#SV</sup>	SYNC5 <sup>#SV</sup>	SYNC4 <sup>#SV</sup>	SYNC3 <sup>#SV</sup>	SYNC2 <sup>#SV</sup>	SYNC1 <sup>#SV</sup>
Gn139								
Gn140	SYNCJ8 <sup>#SV</sup>	SYNCJ7 <sup>#SV</sup>	SYNCJ6 <sup>#SV</sup>	SYNCJ5 <sup>#SV</sup>	SYNCJ4 <sup>#SV</sup>	SYNCJ3 <sup>#SV</sup>	SYNCJ2 <sup>#SV</sup>	SYNCJ1 <sup>#SV</sup>
Gn141								
Gn142	EBUFA <sup>#PX</sup>	ECLRA <sup>#PX</sup>	ESTPA <sup>#PX</sup>	ESOFA <sup>#PX</sup>	ESBKA <sup>#PX</sup>	EMBUFA <sup>#PX</sup>	ELCKZA <sup>#PX</sup>	EFINA <sup>#PX</sup>

Address	Bit number							
	7	6	5	4	3	2	1	0
Gn143	EMSBKA <sup>#PX</sup>	EC6A <sup>#PX</sup>	EC5A <sup>#PX</sup>	EC4A <sup>#PX</sup>	EC3A <sup>#PX</sup>	EC2A <sup>#PX</sup>	EC1A <sup>#PX</sup>	EC0A <sup>#PX</sup>
Gn144	EIF7A <sup>#PX</sup>	EIF6A <sup>#PX</sup>	EIF5A <sup>#PX</sup>	EIF4A <sup>#PX</sup>	EIF3A <sup>#PX</sup>	EIF2A <sup>#PX</sup>	EIF1A <sup>#PX</sup>	EIF0A <sup>#PX</sup>
Gn145	EIF15A <sup>#PX</sup>	EIF14A <sup>#PX</sup>	EIF13A <sup>#PX</sup>	EIF12A <sup>#PX</sup>	EIF11A <sup>#PX</sup>	EIF10A <sup>#PX</sup>	EIF9A <sup>#PX</sup>	EIF8A <sup>#PX</sup>
Gn146	EID7A <sup>#PX</sup>	EID6A <sup>#PX</sup>	EID5A <sup>#PX</sup>	EID4A <sup>#PX</sup>	EID3A <sup>#PX</sup>	EID2A <sup>#PX</sup>	EID1A <sup>#PX</sup>	EID0A <sup>#PX</sup>
Gn147	EID15A <sup>#PX</sup>	EID14A <sup>#PX</sup>	EID13A <sup>#PX</sup>	EID12A <sup>#PX</sup>	EID11A <sup>#PX</sup>	EID10A <sup>#PX</sup>	EID9A <sup>#PX</sup>	EID8A <sup>#PX</sup>
Gn148	EID23A <sup>#PX</sup>	EID22A <sup>#PX</sup>	EID21A <sup>#PX</sup>	EID20A <sup>#PX</sup>	EID19A <sup>#PX</sup>	EID18A <sup>#PX</sup>	EID17A <sup>#PX</sup>	EID16A <sup>#PX</sup>
Gn149	EID31A <sup>#PX</sup>	EID30A <sup>#PX</sup>	EID29A <sup>#PX</sup>	EID28A <sup>#PX</sup>	EID27A <sup>#PX</sup>	EID26A <sup>#PX</sup>	EID25A <sup>#PX</sup>	EID24A <sup>#PX</sup>
Gn150	EDRN <sup>#P</sup>	ERT <sup>#P</sup>	EOVC <sup>#P</sup>				EROV2 <sup>#P</sup>	EROV1 <sup>#P</sup>
Gn151	*EFOV7 <sup>#P</sup> *EROV7 <sup>#P</sup>	*EFOV6 <sup>#P</sup> *EROV6 <sup>#P</sup>	*EFOV5 <sup>#P</sup> *EROV5 <sup>#P</sup>	*EFOV4 <sup>#P</sup> *EROV4 <sup>#P</sup>	*EFOV3 <sup>#P</sup> *EROV3 <sup>#P</sup>	*EFOV2 <sup>#P</sup> *EROV2 <sup>#P</sup>	*EFOV1 <sup>#P</sup> *EROV1 <sup>#P</sup>	*EFOV0 <sup>#P</sup> *EROV0 <sup>#P</sup>
Gn152								
Gn153								
Gn154	EBUFB <sup>#PX</sup>	ECLRB <sup>#PX</sup>	ESTPB <sup>#PX</sup>	ESOFB <sup>#PX</sup>	ESBKB <sup>#PX</sup>	EMBUFB <sup>#PX</sup>	ELCKZB <sup>#PX</sup>	EFINB <sup>#PX</sup>
Gn155	EMSBKB <sup>#PX</sup>	EC6B <sup>#PX</sup>	EC5B <sup>#PX</sup>	EC4B <sup>#PX</sup>	EC3B <sup>#PX</sup>	EC2B <sup>#PX</sup>	EC1B <sup>#PX</sup>	EC0B <sup>#PX</sup>
Gn156	EIF7B <sup>#PX</sup>	EIF6B <sup>#PX</sup>	EIF5B <sup>#PX</sup>	EIF4B <sup>#PX</sup>	EIF3B <sup>#PX</sup>	EIF2B <sup>#PX</sup>	EIF1B <sup>#PX</sup>	EIF0B <sup>#PX</sup>
Gn157	EIF15B <sup>#PX</sup>	EIF14B <sup>#PX</sup>	EIF13B <sup>#PX</sup>	EIF12B <sup>#PX</sup>	EIF11B <sup>#PX</sup>	EIF10B <sup>#PX</sup>	EIF9B <sup>#PX</sup>	EIF8B <sup>#PX</sup>
Gn158	EID7B <sup>#PX</sup>	EID6B <sup>#PX</sup>	EID5B <sup>#PX</sup>	EID4B <sup>#PX</sup>	EID3B <sup>#PX</sup>	EID2B <sup>#PX</sup>	EID1B <sup>#PX</sup>	EID0B <sup>#PX</sup>
Gn159	EID15B <sup>#PX</sup>	EID14B <sup>#PX</sup>	EID13B <sup>#PX</sup>	EID12B <sup>#PX</sup>	EID11B <sup>#PX</sup>	EID10B <sup>#PX</sup>	EID9B <sup>#PX</sup>	EID8B <sup>#PX</sup>
Gn160	EID23B <sup>#PX</sup>	EID22B <sup>#PX</sup>	EID21B <sup>#PX</sup>	EID20B <sup>#PX</sup>	EID19B <sup>#PX</sup>	EID18B <sup>#PX</sup>	EID17B <sup>#PX</sup>	EID16B <sup>#PX</sup>
Gn161	EID31B <sup>#PX</sup>	EID30B <sup>#PX</sup>	EID29B <sup>#PX</sup>	EID28B <sup>#PX</sup>	EID27B <sup>#PX</sup>	EID26B <sup>#PX</sup>	EID25B <sup>#PX</sup>	EID24B <sup>#PX</sup>
Gn162			EOVCB <sup>#PX</sup>					
Gn163	*EFOV7B <sup>#PX</sup> *EROV7B <sup>#PX</sup>	*EFOV6B <sup>#PX</sup> *EROV6B <sup>#PX</sup>	*EFOV5B <sup>#PX</sup> *EROV5B <sup>#PX</sup>	*EFOV4B <sup>#PX</sup> *EROV4B <sup>#PX</sup>	*EFOV3B <sup>#PX</sup> *EROV3B <sup>#PX</sup>	*EFOV2B <sup>#PX</sup> *EROV2B <sup>#PX</sup>	*EFOV1B <sup>#PX</sup> *EROV1B <sup>#PX</sup>	*EFOV0B <sup>#PX</sup> *EROV0B <sup>#PX</sup>
Gn164								
Gn165								
Gn166	EBUFC <sup>#PX</sup>	ECLRC <sup>#PX</sup>	ESTPC <sup>#PX</sup>	ESOFc <sup>#PX</sup>	ESBKC <sup>#PX</sup>	EMBUFC <sup>#PX</sup>	ELCKZC <sup>#PX</sup>	EFINC <sup>#PX</sup>

Address	Bit number							
	7	6	5	4	3	2	1	0
Gn167	EMSBK <sup>#PX</sup>	EC6C <sup>#PX</sup>	EC5C <sup>#PX</sup>	EC4C <sup>#PX</sup>	EC3C <sup>#PX</sup>	EC2C <sup>#PX</sup>	EC1C <sup>#PX</sup>	EC0C <sup>#PX</sup>
Gn168	EIF7C <sup>#PX</sup>	EIF6C <sup>#PX</sup>	EIF5C <sup>#PX</sup>	EIF4C <sup>#PX</sup>	EIF3C <sup>#PX</sup>	EIF2C <sup>#PX</sup>	EIF1C <sup>#PX</sup>	EIF0C <sup>#PX</sup>
Gn169	EIF15C <sup>#PX</sup>	EIF14C <sup>#PX</sup>	EIF13C <sup>#PX</sup>	EIF12C <sup>#PX</sup>	EIF11C <sup>#PX</sup>	EIF10C <sup>#PX</sup>	EIF9C <sup>#PX</sup>	EIF8C <sup>#PX</sup>
Gn170	EID7C <sup>#PX</sup>	EID6C <sup>#PX</sup>	EID5C <sup>#PX</sup>	EID4C <sup>#PX</sup>	EID3C <sup>#PX</sup>	EID2C <sup>#PX</sup>	EID1C <sup>#PX</sup>	EID0C <sup>#PX</sup>
Gn171	EID15C <sup>#PX</sup>	EID14C <sup>#PX</sup>	EID13C <sup>#PX</sup>	EID12C <sup>#PX</sup>	EID11C <sup>#PX</sup>	EID10C <sup>#PX</sup>	EID9C <sup>#PX</sup>	EID8C <sup>#PX</sup>
Gn172	EID23C <sup>#PX</sup>	EID22C <sup>#PX</sup>	EID21C <sup>#PX</sup>	EID20C <sup>#PX</sup>	EID19C <sup>#PX</sup>	EID18C <sup>#PX</sup>	EID17C <sup>#PX</sup>	EID16C <sup>#PX</sup>
Gn173	EID31C <sup>#PX</sup>	EID30C <sup>#PX</sup>	EID29C <sup>#PX</sup>	EID28C <sup>#PX</sup>	EID27C <sup>#PX</sup>	EID26C <sup>#PX</sup>	EID25C <sup>#PX</sup>	EID24C <sup>#PX</sup>
Gn174			EOVCC <sup>#PX</sup>					
Gn175	*EFOV7C <sup>#PX</sup> *EROV7C <sup>#PX</sup>	*EFOV6C <sup>#PX</sup> *EROV6C <sup>#PX</sup>	*EFOV5C <sup>#PX</sup> *EROV5C <sup>#PX</sup>	*EFOV4C <sup>#PX</sup> *EROV4C <sup>#PX</sup>	*EFOV3C <sup>#PX</sup> *EROV3C <sup>#PX</sup>	*EFOV2C <sup>#PX</sup> *EROV2C <sup>#PX</sup>	*EFOV1C <sup>#PX</sup> *EROV1C <sup>#PX</sup>	*EFOV0C <sup>#PX</sup> *EROV0C <sup>#PX</sup>
Gn176								
Gn177								
Gn178	EBUFD <sup>#PX</sup>	ECLRD <sup>#PX</sup>	ESTPD <sup>#PX</sup>	ESOFD <sup>#PX</sup>	ESBKD <sup>#PX</sup>	EMBUFD <sup>#PX</sup>	ELCKZD <sup>#PX</sup>	EFIND <sup>#PX</sup>
Gn179	EMSBKD <sup>#PX</sup>	EC6D <sup>#PX</sup>	EC5D <sup>#PX</sup>	EC4D <sup>#PX</sup>	EC3D <sup>#PX</sup>	EC2D <sup>#PX</sup>	EC1D <sup>#PX</sup>	EC0D <sup>#PX</sup>
Gn180	EIF7D <sup>#PX</sup>	EIF6D <sup>#PX</sup>	EIF5D <sup>#PX</sup>	EIF4D <sup>#PX</sup>	EIF3D <sup>#PX</sup>	EIF2D <sup>#PX</sup>	EIF1D <sup>#PX</sup>	EIF0D <sup>#PX</sup>
Gn181	EIF15D <sup>#PX</sup>	EIF14D <sup>#PX</sup>	EIF13D <sup>#PX</sup>	EIF12D <sup>#PX</sup>	EIF11D <sup>#PX</sup>	EIF10D <sup>#PX</sup>	EIF9D <sup>#PX</sup>	EIF8D <sup>#PX</sup>
Gn182	EID7D <sup>#PX</sup>	EID6D <sup>#PX</sup>	EID5D <sup>#PX</sup>	EID4D <sup>#PX</sup>	EID3D <sup>#PX</sup>	EID2D <sup>#PX</sup>	EID1D <sup>#PX</sup>	EID0D <sup>#PX</sup>
Gn183	EID15D <sup>#PX</sup>	EID14D <sup>#PX</sup>	EID13D <sup>#PX</sup>	EID12D <sup>#PX</sup>	EID11D <sup>#PX</sup>	EID10D <sup>#PX</sup>	EID9D <sup>#PX</sup>	EID8D <sup>#PX</sup>
Gn184	EID23D <sup>#PX</sup>	EID22D <sup>#PX</sup>	EID21D <sup>#PX</sup>	EID20D <sup>#PX</sup>	EID19D <sup>#PX</sup>	EID18D <sup>#PX</sup>	EID17D <sup>#PX</sup>	EID16D <sup>#PX</sup>
Gn185	EID31D <sup>#PX</sup>	EID30D <sup>#PX</sup>	EID29D <sup>#PX</sup>	EID28D <sup>#PX</sup>	EID27D <sup>#PX</sup>	EID26D <sup>#PX</sup>	EID25D <sup>#PX</sup>	EID24D <sup>#PX</sup>
Gn186			EOVCD <sup>#PX</sup>					
Gn187	*EFOV7D <sup>#PX</sup> *EROV7D <sup>#PX</sup>	*EFOV6D <sup>#PX</sup> *EROV6D <sup>#PX</sup>	*EFOV5D <sup>#PX</sup> *EROV5D <sup>#PX</sup>	*EFOV4D <sup>#PX</sup> *EROV4D <sup>#PX</sup>	*EFOV3D <sup>#PX</sup> *EROV3D <sup>#PX</sup>	*EFOV2D <sup>#PX</sup> *EROV2D <sup>#PX</sup>	*EFOV1D <sup>#PX</sup> *EROV1D <sup>#PX</sup>	*EFOV0D <sup>#PX</sup> *EROV0D <sup>#PX</sup>
Gn188								
Gn189								
Gn190	OVLS8 <sup>#SV</sup>	OVLS7 <sup>#SV</sup>	OVLS6 <sup>#SV</sup>	OVLS5 <sup>#SV</sup>	OVLS4 <sup>#SV</sup>	OVLS3 <sup>#SV</sup>	OVLS2 <sup>#SV</sup>	OVLS1 <sup>#SV</sup>

Address	Bit number							
	7	6	5	4	3	2	1	0
Gn191								
Gn192	IGVRY8 <sup>#SV</sup>	IGVRY7 <sup>#SV</sup>	IGVRY6 <sup>#SV</sup>	IGVRY5 <sup>#SV</sup>	IGVRY4 <sup>#SV</sup>	IGVRY3 <sup>#SV</sup>	IGVRY2 <sup>#SV</sup>	IGVRY1 <sup>#SV</sup>
Gn193					HDSR <sup>#P</sup>			
Gn194								
Gn195								
Gn196	*DEC8 <sup>#SV</sup>	*DEC7 <sup>#SV</sup>	*DEC6 <sup>#SV</sup>	*DEC5 <sup>#SV</sup>	*DEC4 <sup>#SV</sup>	*DEC3 <sup>#SV</sup>	*DEC2 <sup>#SV</sup>	*DEC1 <sup>#SV</sup>
Gn197					MTD	MTC	MTB	MTA
Gn198								
Gn199							IOLBH2	IOLBH1
Gn200	EASIP8 <sup>#SV</sup>	EASIP7 <sup>#SV</sup>	EASIP6 <sup>#SV</sup>	EASIP5 <sup>#SV</sup>	EASIP4 <sup>#SV</sup>	EASIP3 <sup>#SV</sup>	EASIP2 <sup>#SV</sup>	EASIP1 <sup>#SV</sup>
Gn201								
Gn202	NDCAL8 <sup>#SV</sup>	NDCAL7 <sup>#SV</sup>	NDCAL6 <sup>#SV</sup>	NDCAL5 <sup>#SV</sup>	NDCAL4 <sup>#SV</sup>	NDCAL3 <sup>#SV</sup>	NDCAL2 <sup>#SV</sup>	NDCAL1 <sup>#SV</sup>
Gn203	RWFL	AOFS2 <sup>#P</sup>	AOFS1 <sup>#P</sup>	CHGAO <sup>#P</sup>	ESTPR <sup>#P</sup>			
Gn204	MRDYC <sup>#SP</sup>	ORCMC <sup>#SP</sup>	SFRC <sup>#SP</sup>	SRVC <sup>#SP</sup>	CTH1C <sup>#SP</sup>	CTH2C <sup>#SP</sup>	TLMHC <sup>#SP</sup>	TLMLC <sup>#SP</sup>
Gn205	RCHC <sup>#SP</sup>	RSLC <sup>#SP</sup>	INTGC <sup>#SP</sup>	SOCNC <sup>#SP</sup>	MCFNC <sup>#SP</sup>	SPSLC <sup>#SP</sup>	*ESPC <sup>#SP</sup>	ARSTC <sup>#SP</sup>
Gn206	RCHHGC <sup>#SP</sup>	MFNHGC <sup>#SP</sup>	INCMDC <sup>#SP</sup>	OVRIDC <sup>#S</sup> <sub>P</sub>	DEFMDC <sup>#SP</sup>	NRROC <sup>#SP</sup>	ROTAC <sup>#SP</sup>	INDXC <sup>#SP</sup>
Gn207						MPOFC <sup>#SP</sup>	SLVC <sup>#SP</sup>	MORCMC <sup>#SP</sup>
Gn208	SH07C <sup>#SP</sup>	SH06C <sup>#SP</sup>	SH05C <sup>#SP</sup>	SH04C <sup>#SP</sup>	SH03C <sup>#SP</sup>	SH02C <sup>#SP</sup>	SH01C <sup>#SP</sup>	SH00C <sup>#SP</sup>
Gn209					SH11C <sup>#SP</sup>	SH10C <sup>#SP</sup>	SH09C <sup>#SP</sup>	SH08C <sup>#SP</sup>
Gn210	ED23 <sup>#P</sup>	ED22 <sup>#P</sup>	ED21 <sup>#P</sup>	ED20 <sup>#P</sup>	ED19 <sup>#P</sup>	ED18 <sup>#P</sup>	ED17 <sup>#P</sup>	ED16 <sup>#P</sup>
Gn211	ED31 <sup>#P</sup>	ED30 <sup>#P</sup>	ED29 <sup>#P</sup>	ED28 <sup>#P</sup>	ED27 <sup>#P</sup>	ED26 <sup>#P</sup>	ED25 <sup>#P</sup>	ED24 <sup>#P</sup>
Gn212								
Gn213								
Gn214								

Address	Bit number							
	7	6	5	4	3	2	1	0
Gn215								
Gn216								
Gn217								
Gn220	*CGROV7#P	*CGROV6#P	*CGROV5#P	*CGROV4#P	*CGROV3#P	*CGROV2#P	*CGROV1#P	*CGROV0#P
Gn251							LCBS	
Gn263								
Gn264					ESSYC4#SP	ESSYC3#SP	ESSYC2#SP	ESSYC1#SP
Gn265					PKESE4#SP	PKESE3#SP	PKESE2#SP	PKESE1#SP
Gn266	MRDYD#SP	ORCMD#SP	SFRD#SP	SRVD#SP	CTH1D#SP	CTH2D#SP	TLMHD#SP	TLMLD#SP
Gn267	RCHD#SP	RSLD#SP	INTGD#SP	SOCND#SP	MCFND#SP	SPSLD#SP	*ESPD#SP	ARSTD#SP
Gn268	RCHHGD#SP	MFNHGD#SP	INCMD#SP	OVRIDD <sub>P</sub> #S	DEFMDD#SP	NRROD#SP	ROTAD#SP	INDXD#SP
Gn269						MPOFD#SP	SLVD#SP	MORC MD#SP
Gn270	SH07D#SP	SH06D#SP	SH05D#SP	SH04D#SP	SH03D#SP	SH02D#SP	SH01D#SP	SH00D#SP
Gn271					SH11D#SP	SH10D#SP	SH09D#SP	SH08D#SP
Gn272	R08I4#SP	R07I4#SP	R06I4#SP	R05I4#SP	R04I4#SP	R03I4#SP	R02I4#SP	R01I4#SP
Gn273	SIND4#SP	SSIN4#SP	SGN4#SP		R12I4#SP	R11I4#SP	R10I4#SP	R09I4#SP
Gn274	CSFI4#SP	CSFI3#SP	CSFI2#SP	CSFI1#SP	CONS4#SP	CONS3#SP	CONS2#SP	CONS1#SP
Gn275								
Gn276	UI107#P	UI106#P	UI105#P	UI104#P	UI103#P	UI102#P	UI101#P	UI100#P
Gn277	UI115#P	UI114#P	UI113#P	UI112#P	UI111#P	UI110#P	UI109#P	UI108#P
Gn278	UI123#P	UI122#P	UI121#P	UI120#P	UI119#P	UI118#P	UI117#P	UI116#P
Gn279	UI131#P	UI130#P	UI129#P	UI128#P	UI127#P	UI126#P	UI125#P	UI124#P
Gn280	UI207#P	UI206#P	UI205#P	UI204#P	UI203#P	UI202#P	UI201#P	UI200#P
Gn281	UI215#P	UI214#P	UI213#P	UI212#P	UI211#P	UI210#P	UI209#P	UI208#P

Address	Bit number							
	7	6	5	4	3	2	1	0
Gn282	UI223 <sup>#P</sup>	UI222 <sup>#P</sup>	UI221 <sup>#P</sup>	UI220 <sup>#P</sup>	UI219 <sup>#P</sup>	UI218 <sup>#P</sup>	UI217 <sup>#P</sup>	UI216 <sup>#P</sup>
Gn283	UI231 <sup>#P</sup>	UI230 <sup>#P</sup>	UI229 <sup>#P</sup>	UI228 <sup>#P</sup>	UI227 <sup>#P</sup>	UI226 <sup>#P</sup>	UI225 <sup>#P</sup>	UI224 <sup>#P</sup>
Gn284	UI307 <sup>#P</sup>	UI306 <sup>#P</sup>	UI305 <sup>#P</sup>	UI304 <sup>#P</sup>	UI303 <sup>#P</sup>	UI302 <sup>#P</sup>	UI301 <sup>#P</sup>	UI300 <sup>#P</sup>
Gn285	UI315 <sup>#P</sup>	UI314 <sup>#P</sup>	UI313 <sup>#P</sup>	UI312 <sup>#P</sup>	UI311 <sup>#P</sup>	UI310 <sup>#P</sup>	UI309 <sup>#P</sup>	UI308 <sup>#P</sup>
Gn286	UI323 <sup>#P</sup>	UI322 <sup>#P</sup>	UI321 <sup>#P</sup>	UI320 <sup>#P</sup>	UI319 <sup>#P</sup>	UI318 <sup>#P</sup>	UI317 <sup>#P</sup>	UI316 <sup>#P</sup>
Gn287	UI331 <sup>#P</sup>	UI330 <sup>#P</sup>	UI329 <sup>#P</sup>	UI328 <sup>#P</sup>	UI327 <sup>#P</sup>	UI326 <sup>#P</sup>	UI325 <sup>#P</sup>	UI324 <sup>#P</sup>
Gn288					SPSYC4 <sup>#SP</sup>	SPSYC3 <sup>#SP</sup>	SPSYC2 <sup>#SP</sup>	SPSYC1 <sup>#SP</sup>
Gn289					SPPHS4 <sup>#SP</sup>	SPPHS3 <sup>#SP</sup>	SPPHS2 <sup>#SP</sup>	SPPHS1 <sup>#SP</sup>
Gn290			PGCK <sup>#P</sup>					
Gn291								
Gn292	ITCD	ITCD3	ITCD2	ITCD1	ITRC			
Gn293								
Gn294								
Gn295	CNCKY	C2SEND						
Gn296	DI8 <sup>#SV</sup>	DI7 <sup>#SV</sup>	DI6 <sup>#SV</sup>	DI5 <sup>#SV</sup>	DI4 <sup>#SV</sup>	DI3 <sup>#SV</sup>	DI2 <sup>#SV</sup>	DI1 <sup>#SV</sup>
Gn297		AOFS2 <sup>#P</sup>	AOFS1 <sup>#P</sup>	CHGAO <sup>#P</sup>				BCAN <sup>#P</sup>
Gn298						RNDH <sup>#P</sup>		TB_BASE <sup>#P</sup>
Gn299								
Gn300								
Gn301								
Gn302								
Gn303								
Gn304					CSYCA <sup>#SP</sup>			
Gn305								

Address	Bit number							
	7	6	5	4	3	2	1	0
Gn306								
Gn307								
Gn308					CSYCB <sup>#SP</sup>			
Gn309								
Gn310								
Gn311								
Gn312					CSYCC <sup>#SP</sup>			
Gn313								
Gn314								
Gn315								
Gn316					CSYCD <sup>#SP</sup>			
Gn317								
Gn318								
Gn319								
Gn320								
Gn321								
Gn322								
Gn323								
Gn324								
Gn325								
Gn326								
Gn327								
Gn328	TLRST4 <sup>#P</sup>	TLRST3 <sup>#P</sup>	TLRST2 <sup>#P</sup>	TLRST1 <sup>#P</sup>	TLRST4 <sup>#P</sup>	TLRST3 <sup>#P</sup>	TLRST2 <sup>#P</sup>	TLRST1 <sup>#P</sup>
Gn329	TLNCT4 <sup>#P</sup>	TLNCT3 <sup>#P</sup>	TLNCT2 <sup>#P</sup>	TLNCT1 <sup>#P</sup>	TLSKP4 <sup>#P</sup>	TLSKP3 <sup>#P</sup>	TLSKP2 <sup>#P</sup>	TLSKP1 <sup>#P</sup>

Address	Bit number							
	7	6	5	4	3	2	1	0
Gn330			TKEY5	TKEY4	TKEY3	TKEY2	TKEY1	TKEY0
Gn331								
Gn332								
Gn333								
Gn334								
Gn335								
Gn336								
Gn337								
Gn338								
Gn339								
Gn340								
Gn341	*+ED48 <sup>#SV</sup>	*+ED47 <sup>#SV</sup>	*+ED46 <sup>#SV</sup>	*+ED45 <sup>#SV</sup>	*+ED44 <sup>#SV</sup>	*+ED43 <sup>#SV</sup>	*+ED42 <sup>#SV</sup>	*+ED41 <sup>#SV</sup>
Gn342	*-ED48 <sup>#SV</sup>	*-ED47 <sup>#SV</sup>	*-ED46 <sup>#SV</sup>	*-ED45 <sup>#SV</sup>	*-ED44 <sup>#SV</sup>	*-ED43 <sup>#SV</sup>	*-ED42 <sup>#SV</sup>	*-ED41 <sup>#SV</sup>
Gn343	*+ED58 <sup>#SV</sup>	*+ED57 <sup>#SV</sup>	*+ED56 <sup>#SV</sup>	*+ED55 <sup>#SV</sup>	*+ED54 <sup>#SV</sup>	*+ED53 <sup>#SV</sup>	*+ED52 <sup>#SV</sup>	*+ED51 <sup>#SV</sup>
Gn344	*-ED58 <sup>#SV</sup>	*-ED57 <sup>#SV</sup>	*-ED56 <sup>#SV</sup>	*-ED55 <sup>#SV</sup>	*-ED54 <sup>#SV</sup>	*-ED53 <sup>#SV</sup>	*-ED52 <sup>#SV</sup>	*-ED51 <sup>#SV</sup>
Gn345								
Gn346								
Gn347	NOT3DM <sup>#P</sup>						HDN <sup>#P</sup>	
Gn348								
Gn349								
Gn350								
Gn351								
Gn352	*FHRO7 <sup>#P</sup>	*FHRO6 <sup>#P</sup>	*FHRO5 <sup>#P</sup>	*FHRO4 <sup>#P</sup>	*FHRO3 <sup>#P</sup>	*FHRO2 <sup>#P</sup>	*FHRO1 <sup>#P</sup>	*FHRO0 <sup>#P</sup>
Gn353	FHROV <sup>#P</sup>						*FHRO9 <sup>#P</sup>	*FHRO8 <sup>#P</sup>



Address	Bit number							
	7	6	5	4	3	2	1	0
Gn354	THD07 <sup>#P</sup>	THD06 <sup>#P</sup>	THD05 <sup>#P</sup>	THD04 <sup>#P</sup>	THD03 <sup>#P</sup>	THD02 <sup>#P</sup>	THD01 <sup>#P</sup>	THD00 <sup>#P</sup>
Gn355	THD15 <sup>#P</sup>	THD14 <sup>#P</sup>	THD13 <sup>#P</sup>	THD12 <sup>#P</sup>	THD11 <sup>#P</sup>	THD10 <sup>#P</sup>	THD09 <sup>#P</sup>	THD08 <sup>#P</sup>
Gn356							THSTB <sup>#P</sup>	THML <sup>#P</sup>
Gn357								
Gn358	WPRST8	WPRST7	WPRST6	WPRST5	WPRST4	WPRST3	WPRST2	WPRST1
~								
Gn375								
Gn376	SOV27	SOV26	SOV25	SOV24	SOV23	SOV22	SOV21	SOV20
Gn377	SOV37	SOV36	SOV35	SOV34	SOV33	SOV32	SOV31	SOV30
Gn378	SOV47	SOV46	SOV45	SOV44	SOV43	SOV42	SOV41	SOV40
Gn379	HS5ID <sup>#P</sup>	HS5IC <sup>#P</sup>	HS5IB <sup>#P</sup>	HS5IA <sup>#P</sup>	HS5D <sup>#P</sup>	HS5C <sup>#P</sup>	HS5B <sup>#P</sup>	HS5A <sup>#P</sup>
Gn380							MP52 <sup>#P</sup>	MP51 <sup>#P</sup>
Gn381								
Gn382								
Gn383								
Gn384								
Gn385								
Gn386								
Gn387								
Gn388								
Gn389								
Gn390								
Gn391								
Gn392								

Address	Bit number							
	7	6	5	4	3	2	1	0
Gn393								
Gn394								
Gn395								
Gn396								
Gn397								
Gn398								
Gn399								
Gn400					*SUCPFD <sup>#SP</sup>	*SUCPFC <sup>#SP</sup>	*SUCPFB <sup>#SP</sup>	
Gn401					*SCPFD <sup>#SP</sup>	*SCPFC <sup>#SP</sup>	*SCPFB <sup>#SP</sup>	
Gn402					SPSTPD <sup>#SP</sup>	SPSTPC <sup>#SP</sup>	SPSTPB <sup>#SP</sup>	
Gn403			SLPCD <sup>#P</sup>	SLPCC <sup>#P</sup>			SLSPD <sup>#P</sup>	SLSPC <sup>#P</sup>
Gn404								
Gn405								
Gn406	ITF08 <sup>#P</sup>	ITF07 <sup>#P</sup>	ITF06 <sup>#P</sup>	ITF05 <sup>#P</sup>	ITF04 <sup>#P</sup>	ITF03 <sup>#P</sup>	ITF02 <sup>#P</sup>	ITF01 <sup>#P</sup>
Gn407				ITCD6	ITCD5	ITCD4	ITF10 <sup>#P</sup>	ITF09 <sup>#P</sup>
Gn408					MDISL	HEAD4	HEAD3	STCHK <sup>#P</sup>
Gn409								
Gn410								
Gn411	HS4IE <sup>#P</sup>	HS3IE <sup>#P</sup>	HS2IE <sup>#P</sup>	HS1IE <sup>#P</sup>	HS4E <sup>#P</sup>	HS3E <sup>#S</sup>	HS2E <sup>#P</sup>	HS1E <sup>#P</sup>
Gn412				HS5IE <sup>#P</sup>				HS1E <sup>#P</sup>
~								
Gn512	MCST8 <sup>#P</sup>	MCST7 <sup>#P</sup>	MCST6 <sup>#P</sup>	MCST5 <sup>#P</sup>	MCST4 <sup>#P</sup>	MCST3 <sup>#P</sup>	MCST2 <sup>#P</sup>	MCST1 <sup>#P</sup>
Gn513	MCST16 <sup>#P</sup>	MCST15 <sup>#P</sup>	MCST14 <sup>#P</sup>	MCST13 <sup>#P</sup>	MCST12 <sup>#P</sup>	MCST11 <sup>#P</sup>	MCST10 <sup>#P</sup>	MCST9 <sup>#P</sup>

Address	Bit number							
	7	6	5	4	3	2	1	0
Gn514								MCFIN <sup>#P</sup>
Gn515	PPK8 <sup>#SV</sup>	PPK7 <sup>#SV</sup>	PPK6 <sup>#SV</sup>	PPK5 <sup>#SV</sup>	PPK4 <sup>#SV</sup>	PPK3 <sup>#SV</sup>	PPK2 <sup>#SV</sup>	PPK1 <sup>#SV</sup>
Gn516	SEMI8 <sup>#SV</sup>	SEMI7 <sup>#SV</sup>	SEMI6 <sup>#SV</sup>	SEMI5 <sup>#SV</sup>	SEMI4 <sup>#SV</sup>	SEMI3 <sup>#SV</sup>	SEMI2 <sup>#SV</sup>	SEMI1 <sup>#SV</sup>
Gn517						GAE3 <sup>#P</sup>	GAE2 <sup>#P</sup>	GAE1 <sup>#P</sup>
Gn518					TDISD			BOV <sup>#P</sup>
Gn519			TSE <sup>#P</sup>	TDICHG	TDID			PTREQ <sup>#P</sup>
Gn520		PTOV7	PTOV6	PTOV5	PTOV4	PTOV3	PTOV2	PTOV1
Gn521	SRVON8	SRVON7	SRVON6	SRVON5	SRVON4	SRVON3	SRVON2	SRVON1
Gn522	PTSK8 <sup>#P</sup>	PTSK7 <sup>#P</sup>	PTSK6 <sup>#P</sup>	PTSK5 <sup>#P</sup>	PTSK4 <sup>#P</sup>	PTSK3 <sup>#P</sup>	PTSK2 <sup>#P</sup>	PTSK1 <sup>#P</sup>
Gn523	SVRVS8	SVRVS7	SVRVS6	SVRVS5	SVRVS4	SVRVS3	SVRVS2	SVRVS1
Gn524								
Gn525	MT8N07 <sup>#P</sup>	MT8N06 <sup>#P</sup>	MT8N05 <sup>#P</sup>	MT8N04 <sup>#P</sup>	MT8N03 <sup>#P</sup>	MT8N02 <sup>#P</sup>	MT8N01 <sup>#P</sup>	MT8N00 <sup>#P</sup>
Gn526	MT8N15 <sup>#P</sup>	MT8N14 <sup>#P</sup>	MT8N13 <sup>#P</sup>	MT8N12 <sup>#P</sup>	MT8N11 <sup>#P</sup>	MT8N10 <sup>#P</sup>	MT8N09 <sup>#P</sup>	MT8N08 <sup>#P</sup>
Gn527	MT8N23 <sup>#P</sup>	MT8N22 <sup>#P</sup>	MT8N21 <sup>#P</sup>	MT8N20 <sup>#P</sup>	MT8N19 <sup>#P</sup>	MT8N18 <sup>#P</sup>	MT8N17 <sup>#P</sup>	MT8N16 <sup>#P</sup>
Gn528	MT8N31 <sup>#P</sup>	MT8N30 <sup>#P</sup>	MT8N29 <sup>#P</sup>	MT8N28 <sup>#P</sup>	MT8N27 <sup>#P</sup>	MT8N26 <sup>#P</sup>	MT8N25 <sup>#P</sup>	MT8N24 <sup>#P</sup>
~								
Gn530	EGBS8 <sup>#SV</sup>	EGBS7 <sup>#SV</sup>	EGBS6 <sup>#SV</sup>	EGBS5 <sup>#SV</sup>	EGBS4 <sup>#SV</sup>	EGBS3 <sup>#SV</sup>	EGBS2 <sup>#SV</sup>	EGBS1 <sup>#SV</sup>
Gn531				OVLN <sup>#P</sup>	HBTRN <sup>#P</sup>		MRVM <sup>#P</sup>	FWSTP <sup>#P</sup>
Gn532								
Gn533				SSRS <sup>#P</sup>	SSR4 <sup>#SP</sup>	SSR3 <sup>#SP</sup>	SSR2 <sup>#SP</sup>	SSR1 <sup>#SP</sup>
Gn534	TDISAW					AXC4 <sup>#P</sup>	AXC2 <sup>#P</sup>	AXC1 <sup>#P</sup>
Gn535								
Gn536	SPSP <sup>#P</sup>							
~								
Gn544				MHLC5 <sup>#P</sup>	MHLC4 <sup>#P</sup>	MHLC3 <sup>#P</sup>	MHLC2 <sup>#P</sup>	MHLC1 <sup>#P</sup>

Address	Bit number							
	7	6	5	4	3	2	1	0
Gn545				MHUS5 <sup>#P</sup>	MHUS4 <sup>#P</sup>	MHUS3 <sup>#P</sup>	MHUS2 <sup>#P</sup>	MHUS1 <sup>#P</sup>
Gn546	GQSMC <sup>#P</sup>		OFNC5 <sup>#P</sup>	OFNC4 <sup>#P</sup>	OFNC3 <sup>#P</sup>	OFNC2 <sup>#P</sup>	OFNC1 <sup>#P</sup>	OFNC0 <sup>#P</sup>
Gn547		ONSC <sup>#P</sup>			OFNC9 <sup>#P</sup>	OFNC8 <sup>#P</sup>	OFNC7 <sup>#P</sup>	OFNC6 <sup>#P</sup>
Gn548	*CL8 <sup>#SV</sup>	*CL7 <sup>#SV</sup>	*CL6 <sup>#SV</sup>	*CL5 <sup>#SV</sup>	*CL4 <sup>#SV</sup>	*CL3 <sup>#SV</sup>	*CL2 <sup>#SV</sup>	*CL1 <sup>#SV</sup>
Gn549					CONH4 <sup>#SP</sup>	CONH3 <sup>#SP</sup>	CONH2 <sup>#SP</sup>	CONH1 <sup>#SP</sup>
~								
Gn767								

CNC → PMC

Address	Bit number							
	7	6	5	4	3	2	1	0
Fn000	OP <sup>#P</sup>	SA <sup>#P</sup>	STL <sup>#P</sup>	SPL <sup>#P</sup>				RWD <sup>#P</sup>
Fn001	MA <sup>#P</sup>		TAP <sup>#P</sup>	ENB <sup>#SP</sup>	DEN <sup>#P</sup>	BAL <sup>#P</sup>	RST <sup>#P</sup>	AL <sup>#P</sup>
Fn002	MDRN <sup>#P</sup>	CUT <sup>#P</sup>		SRNMV <sup>#P</sup>	THRD <sup>#P</sup>	CSS <sup>#P</sup>	RPDO <sup>#P</sup>	INCH <sup>#P</sup>
Fn003		MEDT <sup>#P</sup>	MMEM <sup>#P</sup>	MRMT <sup>#P</sup>	MMDI <sup>#P</sup>	MJ <sup>#P</sup>	MH <sup>#P</sup>	MINC <sup>#P</sup>
Fn004			MREF <sup>#P</sup>	MAFL <sup>#P</sup>	MSBK <sup>#P</sup>	MABSM <sup>#P</sup>	MMLK <sup>#P</sup>	MBDT1 <sup>#P</sup>
Fn005	MBDT9 <sup>#P</sup>	MBDT8 <sup>#P</sup>	MBDT7 <sup>#P</sup>	MBDT6 <sup>#P</sup>	MBDT5 <sup>#P</sup>	MBDT4 <sup>#P</sup>	MBDT3 <sup>#P</sup>	MBDT2 <sup>#P</sup>
Fn006						ERTVA <sup>#P</sup>	MDIRST <sup>#P</sup>	TPPRS
Fn007	BF <sup>#P</sup>				TF <sup>#P</sup>	SF <sup>#P</sup>		MF <sup>#P</sup>
Fn008			MF3 <sup>#P</sup>	MF2 <sup>#P</sup>				
Fn009	DM00 <sup>#P</sup>	DM01 <sup>#P</sup>	DM02 <sup>#P</sup>	DM30 <sup>#P</sup>				
Fn010	M07 <sup>#P</sup>	M06 <sup>#P</sup>	M05 <sup>#P</sup>	M04 <sup>#P</sup>	M03 <sup>#P</sup>	M02 <sup>#P</sup>	M01 <sup>#P</sup>	M00 <sup>#P</sup>
Fn011	M15 <sup>#P</sup>	M14 <sup>#P</sup>	M13 <sup>#P</sup>	M12 <sup>#P</sup>	M11 <sup>#P</sup>	M10 <sup>#P</sup>	M09 <sup>#P</sup>	M08 <sup>#P</sup>
Fn012	M23 <sup>#P</sup>	M22 <sup>#P</sup>	M21 <sup>#P</sup>	M20 <sup>#P</sup>	M19 <sup>#P</sup>	M18 <sup>#P</sup>	M17 <sup>#P</sup>	M16 <sup>#P</sup>
Fn013	M31 <sup>#P</sup>	M30 <sup>#P</sup>	M29 <sup>#P</sup>	M28 <sup>#P</sup>	M27 <sup>#P</sup>	M26 <sup>#P</sup>	M25 <sup>#P</sup>	M24 <sup>#P</sup>
Fn014	M207 <sup>#P</sup>	M206 <sup>#P</sup>	M205 <sup>#P</sup>	M204 <sup>#P</sup>	M203 <sup>#P</sup>	M202 <sup>#P</sup>	M201 <sup>#P</sup>	M200 <sup>#P</sup>
Fn015	M215 <sup>#P</sup>	M214 <sup>#P</sup>	M213 <sup>#P</sup>	M212 <sup>#P</sup>	M211 <sup>#P</sup>	M210 <sup>#P</sup>	M209 <sup>#P</sup>	M208 <sup>#P</sup>
Fn016	M307 <sup>#P</sup>	M306 <sup>#P</sup>	M305 <sup>#P</sup>	M304 <sup>#P</sup>	M303 <sup>#P</sup>	M302 <sup>#P</sup>	M301 <sup>#P</sup>	M300 <sup>#P</sup>
Fn017	M315 <sup>#P</sup>	M314 <sup>#P</sup>	M313 <sup>#P</sup>	M312 <sup>#P</sup>	M311 <sup>#P</sup>	M310 <sup>#P</sup>	M309 <sup>#P</sup>	M308 <sup>#P</sup>
Fn018								
Fn019								
Fn020								
Fn021								
Fn022	S07 <sup>#P</sup>	S06 <sup>#P</sup>	S05 <sup>#P</sup>	S04 <sup>#P</sup>	S03 <sup>#P</sup>	S02 <sup>#P</sup>	S01 <sup>#P</sup>	S00 <sup>#P</sup>

Address	Bit number							
	7	6	5	4	3	2	1	0
Fn023	S15 <sup>#P</sup>	S14 <sup>#P</sup>	S13 <sup>#P</sup>	S12 <sup>#P</sup>	S11 <sup>#P</sup>	S10 <sup>#P</sup>	S09 <sup>#P</sup>	S08 <sup>#P</sup>
Fn024	S23 <sup>#P</sup>	S22 <sup>#P</sup>	S21 <sup>#P</sup>	S20 <sup>#P</sup>	S19 <sup>#P</sup>	S18 <sup>#P</sup>	S17 <sup>#P</sup>	S16 <sup>#P</sup>
Fn025	S31 <sup>#P</sup>	S30 <sup>#P</sup>	S29 <sup>#P</sup>	S28 <sup>#P</sup>	S27 <sup>#P</sup>	S26 <sup>#P</sup>	S25 <sup>#P</sup>	S24 <sup>#P</sup>
Fn026	T07 <sup>#P</sup>	T06 <sup>#P</sup>	T05 <sup>#P</sup>	T04 <sup>#P</sup>	T03 <sup>#P</sup>	T02 <sup>#P</sup>	T01 <sup>#P</sup>	T00 <sup>#P</sup>
Fn027	T15 <sup>#P</sup>	T14 <sup>#P</sup>	T13 <sup>#P</sup>	T12 <sup>#P</sup>	T11 <sup>#P</sup>	T10 <sup>#P</sup>	T09 <sup>#P</sup>	T08 <sup>#P</sup>
Fn028	T23 <sup>#P</sup>	T22 <sup>#P</sup>	T21 <sup>#P</sup>	T20 <sup>#P</sup>	T19 <sup>#P</sup>	T18 <sup>#P</sup>	T17 <sup>#P</sup>	T16 <sup>#P</sup>
Fn029	T31 <sup>#P</sup>	T30 <sup>#P</sup>	T29 <sup>#P</sup>	T28 <sup>#P</sup>	T27 <sup>#P</sup>	T26 <sup>#P</sup>	T25 <sup>#P</sup>	T24 <sup>#P</sup>
Fn030	B07 <sup>#P</sup>	B06 <sup>#P</sup>	B05 <sup>#P</sup>	B04 <sup>#P</sup>	B03 <sup>#P</sup>	B02 <sup>#P</sup>	B01 <sup>#P</sup>	B00 <sup>#P</sup>
Fn031	B15 <sup>#P</sup>	B14 <sup>#P</sup>	B13 <sup>#P</sup>	B12 <sup>#P</sup>	B11 <sup>#P</sup>	B10 <sup>#P</sup>	B09 <sup>#P</sup>	B08 <sup>#P</sup>
Fn032	B23 <sup>#P</sup>	B22 <sup>#P</sup>	B21 <sup>#P</sup>	B20 <sup>#P</sup>	B19 <sup>#P</sup>	B18 <sup>#P</sup>	B17 <sup>#P</sup>	B16 <sup>#P</sup>
Fn033	B31 <sup>#P</sup>	B30 <sup>#P</sup>	B29 <sup>#P</sup>	B28 <sup>#P</sup>	B27 <sup>#P</sup>	B26 <sup>#P</sup>	B25 <sup>#P</sup>	B24 <sup>#P</sup>
Fn034	SRSRDY <sup>#P</sup>	SRSP1R <sup>#SP</sup>	SRSP2R <sup>#SP</sup>	SRSP3R <sup>#SP</sup>	SRSP4R <sup>#SP</sup>	GR30 <sup>#P</sup>	GR20 <sup>#P</sup>	GR10 <sup>#P</sup>
Fn035								SPAL <sup>#P</sup>
Fn036	R080 <sup>#SP</sup>	R070 <sup>#SP</sup>	R060 <sup>#SP</sup>	R050 <sup>#SP</sup>	R040 <sup>#SP</sup>	R030 <sup>#SP</sup>	R020 <sup>#SP</sup>	R010 <sup>#SP</sup>
Fn037					R120 <sup>#SP</sup>	R110 <sup>#SP</sup>	R100 <sup>#SP</sup>	R090 <sup>#SP</sup>
Fn038					ENB3 <sup>#SP</sup>	ENB2 <sup>#SP</sup>	SUCLPA <sup>#SP</sup>	SCLPA <sup>#SP</sup>
Fn039					CHPCYL <sup>#P</sup>	CHPMD <sup>#P</sup>	ENB4 <sup>#SP</sup>	MSPOSA <sup>#SP</sup>
Fn040	AR07 <sup>#SP</sup>	AR06 <sup>#SP</sup>	AR05 <sup>#SP</sup>	AR04 <sup>#SP</sup>	AR03 <sup>#SP</sup>	AR02 <sup>#SP</sup>	AR01 <sup>#SP</sup>	AR00 <sup>#SP</sup>
Fn041	AR15 <sup>#SP</sup>	AR14 <sup>#SP</sup>	AR13 <sup>#SP</sup>	AR12 <sup>#SP</sup>	AR11 <sup>#SP</sup>	AR10 <sup>#SP</sup>	AR09 <sup>#SP</sup>	AR08 <sup>#SP</sup>
Fn042								
Fn043					SYCAL4 <sup>#SP</sup>	SYCAL3 <sup>#SP</sup>	SYCAL2 <sup>#SP</sup>	SYCAL1 <sup>#SP</sup>
Fn044				SYCAL <sup>#P</sup>	FSPPH <sup>#P</sup>	FSPSY <sup>#P</sup>	FSCSL <sup>#P</sup>	
Fn045	ORARA <sup>#SP</sup>	TLMA <sup>#SP</sup>	LDT2A <sup>#SP</sup>	LDT1A <sup>#SP</sup>	SARA <sup>#SP</sup>	SDTA <sup>#SP</sup>	SSTA <sup>#SP</sup>	ALMA <sup>#SP</sup>
Fn046	MORA2A <sup>#SP</sup>	MORA1A <sup>#SP</sup>	PORA2A <sup>#SP</sup>	SLVSA <sup>#SP</sup>	RCFNA <sup>#SP</sup>	RCHPA <sup>#SP</sup>	CFINA <sup>#SP</sup>	CHIPA <sup>#SP</sup>

Address	Bit number							
	7	6	5	4	3	2	1	0
Fn047	CSYFNA <sup>#SP</sup>	CS1DTA <sup>#SP</sup>					INCSTA <sup>#SP</sup>	PC1DEA <sup>#SP</sup>
Fn048				CSPENA <sup>#SP</sup>				
Fn049	ORARB <sup>#SP</sup>	TLMB <sup>#SP</sup>	LDT2B <sup>#SP</sup>	LDT1B <sup>#SP</sup>	SARB <sup>#SP</sup>	SDTB <sup>#SP</sup>	SSTB <sup>#SP</sup>	ALMB <sup>#SP</sup>
Fn050	MORA2B <sup>#SP</sup>	MORA1B <sup>#SP</sup>	PORA2B <sup>#SP</sup>	SLVSB <sup>#SP</sup>	RCFNB <sup>#SP</sup>	RCHPB <sup>#SP</sup>	CFINB <sup>#SP</sup>	CHIPB <sup>#SP</sup>
Fn051	CSYFNB <sup>#SP</sup>	CS1DTB <sup>#SP</sup>					INCSTB <sup>#SP</sup>	PC1DEB <sup>#SP</sup>
Fn052				CSPENB <sup>#SP</sup>				
Fn053	EKENB				RPALM <sup>#P</sup>	RPBSY <sup>#P</sup>	PRGDPL	INHKY
Fn054	UO007 <sup>#P</sup>	UO006 <sup>#P</sup>	UO005 <sup>#P</sup>	UO004 <sup>#P</sup>	UO003 <sup>#P</sup>	UO002 <sup>#P</sup>	UO001 <sup>#P</sup>	UO000 <sup>#P</sup>
Fn055	UO015 <sup>#P</sup>	UO014 <sup>#P</sup>	UO013 <sup>#P</sup>	UO012 <sup>#P</sup>	UO011 <sup>#P</sup>	UO010 <sup>#P</sup>	UO009 <sup>#P</sup>	UO008 <sup>#P</sup>
Fn056	UO107 <sup>#P</sup>	UO106 <sup>#P</sup>	UO105 <sup>#P</sup>	UO104 <sup>#P</sup>	UO103 <sup>#P</sup>	UO102 <sup>#P</sup>	UO101 <sup>#P</sup>	UO100 <sup>#P</sup>
Fn057	UO115 <sup>#P</sup>	UO114 <sup>#P</sup>	UO113 <sup>#P</sup>	UO112 <sup>#P</sup>	UO111 <sup>#P</sup>	UO110 <sup>#P</sup>	UO109 <sup>#P</sup>	UO108 <sup>#P</sup>
Fn058	UO123 <sup>#P</sup>	UO122 <sup>#P</sup>	UO121 <sup>#P</sup>	UO120 <sup>#P</sup>	UO119 <sup>#P</sup>	UO118 <sup>#P</sup>	UO117 <sup>#P</sup>	UO116 <sup>#P</sup>
Fn059	UO131 <sup>#P</sup>	UO130 <sup>#P</sup>	UO129 <sup>#P</sup>	UO128 <sup>#P</sup>	UO127 <sup>#P</sup>	UO126 <sup>#P</sup>	UO125 <sup>#P</sup>	UO124 <sup>#P</sup>
Fn060						ESCAN <sup>#SP</sup>	ESEND <sup>#P</sup>	EREND <sup>#P</sup>
Fn061			MTLA <sup>#P</sup>	MTLANG <sup>#P</sup>	HCEXE	HCAB2	BCLP <sup>#P</sup>	BUCLP <sup>#P</sup>
Fn062	PRTSF <sup>#P</sup>	D3ROT <sup>#P</sup>		S2MES <sup>#P</sup>	S1MES <sup>#P</sup>	HSRA <sup>#P</sup>		AICC <sup>#P</sup>
Fn063	PSYN <sup>#P</sup>	WATO <sup>#P</sup>		COSP2 <sup>#P</sup>	COSP1 <sup>#P</sup>	PSAR <sup>#P</sup>	PSE2 <sup>#P</sup>	PSE1 <sup>#P</sup>
Fn064	TIALM <sup>#P</sup>	TICLK <sup>#P</sup>	COSP <sup>#P</sup>		TLCHB <sup>#P</sup>	TLCHI <sup>#P</sup>	TLNW <sup>#P</sup>	TLCH <sup>#P</sup>
Fn065		SYNMOD <sup>#P</sup>		RTRCTF <sup>#P</sup>		RSMAX <sup>#P</sup>	RGSPM <sup>#P</sup>	RGSP <sup>#P</sup>
Fn066			PECK2 <sup>#P</sup>			FEED0 <sup>#P</sup>	RTPT <sup>#P</sup>	
Fn067								
Fn068								
Fn069								
Fn070	PSW08 <sup>#P</sup>	PSW07 <sup>#P</sup>	PSW06 <sup>#P</sup>	PSW05 <sup>#P</sup>	PSW04 <sup>#P</sup>	PSW03 <sup>#P</sup>	PSW02 <sup>#P</sup>	PSW01 <sup>#P</sup>

Address	Bit number							
	7	6	5	4	3	2	1	0
Fn071	PSW16 <sup>#P</sup>	PSW15 <sup>#P</sup>	PSW14 <sup>#P</sup>	PSW13 <sup>#P</sup>	PSW12 <sup>#P</sup>	PSW11 <sup>#P</sup>	PSW10 <sup>#P</sup>	PSW09 <sup>#P</sup>
Fn072	OUT7 <sup>#P</sup>	OUT6 <sup>#P</sup>	OUT5 <sup>#P</sup>	OUT4 <sup>#P</sup>	OUT3 <sup>#P</sup>	OUT2 <sup>#P</sup>	OUT1 <sup>#P</sup>	OUT0 <sup>#P</sup>
Fn073				ZRNO <sup>#P</sup>		MD40 <sup>#P</sup>	MD20 <sup>#P</sup>	MD10 <sup>#P</sup>
Fn074	OUT15 <sup>#P</sup>	OUT14 <sup>#P</sup>	OUT13 <sup>#P</sup>	OUT12 <sup>#P</sup>	OUT11 <sup>#P</sup>	OUT10 <sup>#P</sup>	OUT9 <sup>#P</sup>	OUT8 <sup>#P</sup>
Fn075	SPO <sup>#P</sup>	KEYO	DRNO <sup>#P</sup>	MLKO <sup>#P</sup>	SBKO <sup>#P</sup>	BDTO <sup>#P</sup>		
Fn076			ROV20 <sup>#P</sup>	ROV10 <sup>#P</sup>	RTAP <sup>#P</sup>		MP20 <sup>#P</sup>	MP10 <sup>#P</sup>
Fn077		RTO <sup>#P</sup>			HS1DO <sup>#P</sup>	HS1CO <sup>#P</sup>	HS1BO <sup>#P</sup>	HS1AO <sup>#P</sup>
Fn078	*FV70 <sup>#P</sup>	*FV60 <sup>#P</sup>	*FV50 <sup>#P</sup>	*FV40 <sup>#P</sup>	*FV30 <sup>#P</sup>	*FV20 <sup>#P</sup>	*FV10 <sup>#P</sup>	*FV00 <sup>#P</sup>
Fn079	*JV70 <sup>#P</sup>	*JV60 <sup>#P</sup>	*JV50 <sup>#P</sup>	*JV40 <sup>#P</sup>	*JV30 <sup>#P</sup>	*JV20 <sup>#P</sup>	*JV10 <sup>#P</sup>	*JV00 <sup>#P</sup>
Fn080	*JV150 <sup>#P</sup>	*JV140 <sup>#P</sup>	*JV130 <sup>#P</sup>	*JV120 <sup>#P</sup>	*JV110 <sup>#P</sup>	*JV100 <sup>#P</sup>	*JV90 <sup>#P</sup>	*JV80 <sup>#P</sup>
Fn081	-J40 <sup>#P</sup>	+J40 <sup>#P</sup>	-J30 <sup>#P</sup>	+J30 <sup>#P</sup>	-J20 <sup>#P</sup>	+J20 <sup>#P</sup>	-J10 <sup>#P</sup>	+J10 <sup>#P</sup>
Fn082						RVSL <sup>#P</sup>	CGRMD <sup>#P</sup>	
Fn083								
Fn084	EUO07 <sup>#P</sup>	EUO06 <sup>#P</sup>	EUO05 <sup>#P</sup>	EUO04 <sup>#P</sup>	EUO03 <sup>#P</sup>	EUO02 <sup>#P</sup>	EUO01 <sup>#P</sup>	EUO00 <sup>#P</sup>
Fn085	EUO15 <sup>#P</sup>	EUO14 <sup>#P</sup>	EUO13 <sup>#P</sup>	EUO12 <sup>#P</sup>	EUO11 <sup>#P</sup>	EUO10 <sup>#P</sup>	EUO09 <sup>#P</sup>	EUO08 <sup>#P</sup>
Fn086								
Fn087								
Fn088								
Fn089								
Fn090	SVSPM <sup>#P</sup>	SVAR <sup>#P</sup>	SYSSM <sup>#P</sup>	SYAR <sup>#P</sup>	ABTSP3 <sup>=SP</sup>	ABTSP2 <sup>=SP</sup>	ABTSP1 <sup>=SP</sup>	ABTQSV <sup>#P</sup>
Fn091				ABTSP4 <sup>=SP</sup>	MMMOD <sup>#P</sup>	MRVSP <sup>#P</sup>	MNCHG <sup>#P</sup>	MRVMD <sup>#P</sup>
Fn092	HSBIN <sup>#P</sup>		TRSPS <sup>#P</sup>	TRMTN <sup>#P</sup>	TRACT <sup>#P</sup>			
Fn093	SVWRN4 <sup>#P</sup>	SVWRN3 <sup>#P</sup>	SVWRN2 <sup>#P</sup>	SVWRN1 <sup>#P</sup>	WFAN <sup>#P</sup>	LFCIF <sup>#P</sup>	SFAN <sup>#P</sup>	
Fn094	ZP8 <sup>#SV</sup>	ZP7 <sup>#SV</sup>	ZP6 <sup>#SV</sup>	ZP5 <sup>#SV</sup>	ZP4 <sup>#SV</sup>	ZP3 <sup>#SV</sup>	ZP2 <sup>#SV</sup>	ZP1 <sup>#SV</sup>



Address	Bit number							
	7	6	5	4	3	2	1	0
Fn095								
Fn096	ZP28 <sup>#SV</sup>	ZP27 <sup>#SV</sup>	ZP26 <sup>#SV</sup>	ZP25 <sup>#SV</sup>	ZP24 <sup>#SV</sup>	ZP23 <sup>#SV</sup>	ZP22 <sup>#SV</sup>	ZP21 <sup>#SV</sup>
Fn097								
Fn098	ZP38 <sup>#SV</sup>	ZP37 <sup>#SV</sup>	ZP36 <sup>#SV</sup>	ZP35 <sup>#SV</sup>	ZP34 <sup>#SV</sup>	ZP33 <sup>#SV</sup>	ZP32 <sup>#SV</sup>	ZP31 <sup>#SV</sup>
Fn099								
Fn100	ZP48 <sup>#SV</sup>	ZP47 <sup>#SV</sup>	ZP46 <sup>#SV</sup>	ZP45 <sup>#SV</sup>	ZP44 <sup>#SV</sup>	ZP43 <sup>#SV</sup>	ZP42 <sup>#SV</sup>	ZP41 <sup>#SV</sup>
Fn101								
Fn102	MV8 <sup>#SV</sup>	MV7 <sup>#SV</sup>	MV6 <sup>#SV</sup>	MV5 <sup>#SV</sup>	MV4 <sup>#SV</sup>	MV3 <sup>#SV</sup>	MV2 <sup>#SV</sup>	MV1 <sup>#SV</sup>
Fn103								
Fn104	INP8 <sup>#SV</sup>	INP7 <sup>#SV</sup>	INP6 <sup>#SV</sup>	INP5 <sup>#SV</sup>	INP4 <sup>#SV</sup>	INP3 <sup>#SV</sup>	INP2 <sup>#SV</sup>	INP1 <sup>#SV</sup>
Fn105								
Fn106	MVD8 <sup>#SV</sup>	MVD7 <sup>#SV</sup>	MVD6 <sup>#SV</sup>	MVD5 <sup>#SV</sup>	MVD4 <sup>#SV</sup>	MVD3 <sup>#SV</sup>	MVD2 <sup>#SV</sup>	MVD1 <sup>#SV</sup>
Fn107								
Fn108	MMI8 <sup>#SV</sup>	MMI7 <sup>#SV</sup>	MMI6 <sup>#SV</sup>	MMI5 <sup>#SV</sup>	MMI4 <sup>#SV</sup>	MMI3 <sup>#SV</sup>	MMI2 <sup>#SV</sup>	MMI1 <sup>#SV</sup>
Fn109								
Fn110	MDTCH8 <sup>#SV</sup>	MDTCH7 <sup>#SV</sup>	MDTCH6 <sup>#SV</sup>	MDTCH5 <sup>#SV</sup>	MDTCH4 <sup>#SV</sup>	MDTCH3 <sup>#SV</sup>	MDTCH2 <sup>#SV</sup>	MDTCH1 <sup>#SV</sup>
Fn111								
Fn112	EADEN8 <sup>#SV</sup>	EADEN7 <sup>#SV</sup>	EADEN6 <sup>#SV</sup>	EADEN5 <sup>#SV</sup>	EADEN4 <sup>#SV</sup>	EADEN3 <sup>#SV</sup>	EADEN2 <sup>#SV</sup>	EADEN1 <sup>#SV</sup>
Fn113								
Fn114	TRQL8 <sup>#SV</sup>	TRQL7 <sup>#SV</sup>	TRQL6 <sup>#SV</sup>	TRQL5 <sup>#SV</sup>	TRQL4 <sup>#SV</sup>	TRQL3 <sup>#SV</sup>	TRQL2 <sup>#SV</sup>	TRQL1 <sup>#SV</sup>
Fn115								
Fn116	FRP8 <sup>#SV</sup>	FRP7 <sup>#SV</sup>	FRP6 <sup>#SV</sup>	FRP5 <sup>#SV</sup>	FRP4 <sup>#SV</sup>	FRP3 <sup>#SV</sup>	FRP2 <sup>#SV</sup>	FRP1 <sup>#SV</sup>
Fn117								
Fn118	SYN80 <sup>#SV</sup>	SYN70 <sup>#SV</sup>	SYN60 <sup>#SV</sup>	SYN50 <sup>#SV</sup>	SYN40 <sup>#SV</sup>	SYN30 <sup>#SV</sup>	SYN20 <sup>#SV</sup>	SYN10 <sup>#SV</sup>

Address	Bit number							
	7	6	5	4	3	2	1	0
Fn119								
Fn120	ZRF8 <sup>#SV</sup>	ZRF7 <sup>#SV</sup>	ZRF6 <sup>#SV</sup>	ZRF5 <sup>#SV</sup>	ZRF4 <sup>#SV</sup>	ZRF3 <sup>#SV</sup>	ZRF2 <sup>#SV</sup>	ZRF1 <sup>#SV</sup>
Fn121								
Fn122	HDO7 <sup>#P</sup>	HDO6 <sup>#P</sup>	HDO5 <sup>#P</sup>	HDO4 <sup>#P</sup>	HDO3 <sup>#P</sup>	HDO2 <sup>#P</sup>	HDO1 <sup>#P</sup>	HDO0 <sup>#P</sup>
Fn123								
Fn124	+OT8 <sup>#SV</sup>	+OT7 <sup>#SV</sup>	+OT6 <sup>#SV</sup>	+OT5 <sup>#SV</sup>	+OT4 <sup>#SV</sup>	+OT3 <sup>#SV</sup>	+OT2 <sup>#SV</sup>	+OT1 <sup>#SV</sup>
Fn125								
Fn126	-OT8 <sup>#SV</sup>	-OT7 <sup>#SV</sup>	-OT6 <sup>#SV</sup>	-OT5 <sup>#SV</sup>	-OT4 <sup>#SV</sup>	-OT3 <sup>#SV</sup>	-OT2 <sup>#SV</sup>	-OT1 <sup>#SV</sup>
Fn127								
Fn128								
Fn129	*EAXSL <sup>#P</sup>		EOV0 <sup>#P</sup>					
Fn130	EBSYA <sup>#PX</sup>	EOTNA <sup>#PX</sup>	EOTPA <sup>#PX</sup>	EGENA <sup>#PX</sup>	EDENA <sup>#PX</sup>	EIALA <sup>#PX</sup>	ECKZA <sup>#PX</sup>	EINPA <sup>#PX</sup>
Fn131					EMF3A <sup>#PX</sup>	EMF2A <sup>#PX</sup>	EABUFA <sup>#PX</sup>	EMFA <sup>#PX</sup>
Fn132	EM28A <sup>#PX</sup>	EM24A <sup>#PX</sup>	EM22A <sup>#PX</sup>	EM21A <sup>#PX</sup>	EM18A <sup>#PX</sup>	EM14A <sup>#PX</sup>	EM12A <sup>#PX</sup>	EM11A <sup>#PX</sup>
Fn133	EBSYB <sup>#PX</sup>	EOTNB <sup>#PX</sup>	EOTPB <sup>#PX</sup>	EGENB <sup>#PX</sup>	EDENB <sup>#PX</sup>	EIALB <sup>#PX</sup>	ECKZB <sup>#PX</sup>	EINPB <sup>#PX</sup>
Fn134					EMF3B <sup>#PX</sup>	EMF2B <sup>#PX</sup>	EABUFB <sup>#PX</sup>	EMFB <sup>#PX</sup>
Fn135	EM28B <sup>#PX</sup>	EM24B <sup>#PX</sup>	EM22B <sup>#PX</sup>	EM21B <sup>#PX</sup>	EM18B <sup>#PX</sup>	EM14B <sup>#PX</sup>	EM12B <sup>#PX</sup>	EM11B <sup>#PX</sup>
Fn136	EBSYC <sup>#PX</sup>	EOTNC <sup>#PX</sup>	EOTPC <sup>#PX</sup>	EGENC <sup>#PX</sup>	EDENC <sup>#PX</sup>	EIALC <sup>#PX</sup>	ECKZC <sup>#PX</sup>	EINPC <sup>#PX</sup>
Fn137					EMF3C <sup>#PX</sup>	EMF2C <sup>#PX</sup>	EABUFC <sup>#PX</sup>	EMFC <sup>#PX</sup>
Fn138	EM28C <sup>#PX</sup>	EM24C <sup>#PX</sup>	EM22C <sup>#PX</sup>	EM21C <sup>#PX</sup>	EM18C <sup>#PX</sup>	EM14C <sup>#PX</sup>	EM12C <sup>#PX</sup>	EM11C <sup>#PX</sup>
Fn139	EBSYD <sup>#PX</sup>	EOTND <sup>#PX</sup>	EOTPD <sup>#PX</sup>	EGEND <sup>#PX</sup>	EDEND <sup>#PX</sup>	EIALD <sup>#PX</sup>	ECKZD <sup>#PX</sup>	EINPD <sup>#PX</sup>
Fn140					EMF3D <sup>#PX</sup>	EMF2D <sup>#PX</sup>	EABUFD <sup>#PX</sup>	EMFD <sup>#PX</sup>
Fn141	EM28D <sup>#PX</sup>	EM24D <sup>#PX</sup>	EM22D <sup>#PX</sup>	EM21D <sup>#PX</sup>	EM18D <sup>#PX</sup>	EM14D <sup>#PX</sup>	EM12D <sup>#PX</sup>	EM11D <sup>#PX</sup>
Fn142	EM48A <sup>#PX</sup>	EM44A <sup>#PX</sup>	EM42A <sup>#PX</sup>	EM41A <sup>#PX</sup>	EM38A <sup>#PX</sup>	EM34A <sup>#PX</sup>	EM32A <sup>#PX</sup>	EM31A <sup>#PX</sup>

Address	Bit number							
	7	6	5	4	3	2	1	0
Fn143								
Fn144								
Fn145	EM48B <sup>#PX</sup>	EM44B <sup>#PX</sup>	EM42B <sup>#PX</sup>	EM41B <sup>#PX</sup>	EM38B <sup>#PX</sup>	EM34B <sup>#PX</sup>	EM32B <sup>#PX</sup>	EM31B <sup>#PX</sup>
Fn146								
Fn147								
Fn148	EM48C <sup>#PX</sup>	EM44C <sup>#PX</sup>	EM42C <sup>#PX</sup>	EM41C <sup>#PX</sup>	EM38C <sup>#PX</sup>	EM34C <sup>#PX</sup>	EM32C <sup>#PX</sup>	EM31C <sup>#PX</sup>
Fn149								
Fn150								
Fn151	EM48D <sup>#PX</sup>	EM44D <sup>#PX</sup>	EM42D <sup>#PX</sup>	EM41D <sup>#PX</sup>	EM38D <sup>#PX</sup>	EM34D <sup>#PX</sup>	EM32D <sup>#PX</sup>	EM31D <sup>#PX</sup>
Fn152								
Fn153								
Fn154								TLAL <sup>#P</sup>
Fn155								
Fn156								
Fn157								
Fn158								
Fn159								
Fn160	MSP07 <sup>#P</sup>	MSP06 <sup>#P</sup>	MSP05 <sup>#P</sup>	MSP04 <sup>#P</sup>	MSP03 <sup>#P</sup>	MSP02 <sup>#P</sup>	MSP01 <sup>#P</sup>	MSP00 <sup>#P</sup>
Fn161	MSP15 <sup>#P</sup>	MSP14 <sup>#P</sup>	MSP13 <sup>#P</sup>	MSP12 <sup>#P</sup>	MSP11 <sup>#P</sup>	MSP10 <sup>#P</sup>	MSP09 <sup>#P</sup>	MSP08 <sup>#P</sup>
Fn162								
Fn163								
Fn164								
Fn165								
Fn166								

Address	Bit number							
	7	6	5	4	3	2	1	0
Fn167								
Fn168	ORARC <sup>#SP</sup>	TLMC <sup>#SP</sup>	LDT2C <sup>#SP</sup>	LDT1C <sup>#SP</sup>	SARC <sup>#SP</sup>	SDTC <sup>#SP</sup>	SSTC <sup>#SP</sup>	ALMC <sup>#SP</sup>
Fn169	MORA2C <sup>#SP</sup>	MORA1C <sup>#SP</sup>	PORA2C <sup>#SP</sup>	SLVSC <sup>#SP</sup>	RCFNC <sup>#SP</sup>	RCHPC <sup>#SP</sup>	CFINC <sup>#SP</sup>	CHIPC <sup>#SP</sup>
Fn170	CSYFNC <sup>#SP</sup>	CS1DTC <sup>#SP</sup>					INCSTC <sup>#SP</sup>	PC1DEC <sup>#SP</sup>
Fn171				CSPENC <sup>#SP</sup>				
Fn172	PBATL <sup>#P</sup>	PBATZ <sup>#P</sup>						
Fn173								
Fn174								
Fn175								
Fn176								
Fn177								
Fn178								
Fn179								
Fn180	CLRCH8 <sup>#SV</sup>	CLRCH7 <sup>#SV</sup>	CLRCH6 <sup>#SV</sup>	CLRCH5 <sup>#SV</sup>	CLRCH4 <sup>#SV</sup>	CLRCH3 <sup>#SV</sup>	CLRCH2 <sup>#SV</sup>	CLRCH1 <sup>#SV</sup>
Fn181								
Fn182	EACNT8 <sup>#SV</sup>	EACNT7 <sup>#SV</sup>	EACNT6 <sup>#SV</sup>	EACNT5 <sup>#SV</sup>	EACNT4 <sup>#SV</sup>	EACNT3 <sup>#SV</sup>	EACNT2 <sup>#SV</sup>	EACNT1 <sup>#SV</sup>
Fn183								
Fn184	ABDT8 <sup>#SV</sup>	ABDT7 <sup>#SV</sup>	ABDT6 <sup>#SV</sup>	ABDT5 <sup>#SV</sup>	ABDT4 <sup>#SV</sup>	ABDT3 <sup>#SV</sup>	ABDT2 <sup>#SV</sup>	ABDT1 <sup>#SV</sup>
Fn185								
Fn186								
Fn187								
Fn188	AMRST8 <sup>#SV</sup>	AMRST7 <sup>#SV</sup>	AMRST6 <sup>#SV</sup>	AMRST5 <sup>#SV</sup>	AMRST4 <sup>#SV</sup>	AMRST3 <sup>#SV</sup>	AMRST2 <sup>#SV</sup>	AMRST1 <sup>#SV</sup>
Fn189								
Fn190	TRQM8 <sup>#SV</sup>	TRQM7 <sup>#SV</sup>	TRQM6 <sup>#SV</sup>	TRQM5 <sup>#SV</sup>	TRQM4 <sup>#SV</sup>	TRQM3 <sup>#SV</sup>	TRQM2 <sup>#SV</sup>	TRQM1 <sup>#SV</sup>

Address	Bit number							
	7	6	5	4	3	2	1	0
Fn191								
Fn192								
Fn193								
Fn194								
Fn195								
Fn196								
Fn197					MFSYND	MFSYNC	MFSYNB	MFSYNA
Fn198								
Fn199			MCHAO <sup>#P</sup>					
Fn200	R08O2 <sup>#SP</sup>	R07O2 <sup>#SP</sup>	R06O2 <sup>#SP</sup>	R05O2 <sup>#SP</sup>	R04O2 <sup>#SP</sup>	R03O2 <sup>#SP</sup>	R02O2 <sup>#SP</sup>	R01O2 <sup>#SP</sup>
Fn201					R12O2 <sup>#SP</sup>	R11O2 <sup>#SP</sup>	R10O2 <sup>#SP</sup>	R09O2 <sup>#SP</sup>
Fn202	AR072 <sup>#SP</sup>	AR062 <sup>#SP</sup>	AR052 <sup>#SP</sup>	AR042 <sup>#SP</sup>	AR032 <sup>#SP</sup>	AR022 <sup>#SP</sup>	AR012 <sup>#SP</sup>	AR002 <sup>#SP</sup>
Fn203	AR152 <sup>#SP</sup>	AR142 <sup>#SP</sup>	AR132 <sup>#SP</sup>	AR122 <sup>#SP</sup>	AR112 <sup>#SP</sup>	AR102 <sup>#SP</sup>	AR092 <sup>#SP</sup>	AR082 <sup>#SP</sup>
Fn204	R08O3 <sup>#SP</sup>	R07O3 <sup>#SP</sup>	R06O3 <sup>#SP</sup>	R05O3 <sup>#SP</sup>	R04O3 <sup>#SP</sup>	R03O3 <sup>#SP</sup>	R02O3 <sup>#SP</sup>	R01O3 <sup>#SP</sup>
Fn205					R12O3 <sup>#SP</sup>	R11O3 <sup>#SP</sup>	R10O3 <sup>#SP</sup>	R09O3 <sup>#SP</sup>
Fn206	AR073 <sup>#SP</sup>	AR063 <sup>#SP</sup>	AR053 <sup>#SP</sup>	AR043 <sup>#SP</sup>	AR033 <sup>#SP</sup>	AR023 <sup>#SP</sup>	AR013 <sup>#SP</sup>	AR003 <sup>#SP</sup>
Fn207	AR153 <sup>#SP</sup>	AR143 <sup>#SP</sup>	AR133 <sup>#SP</sup>	AR123 <sup>#SP</sup>	AR113 <sup>#SP</sup>	AR103 <sup>#SP</sup>	AR093 <sup>#SP</sup>	AR083 <sup>#SP</sup>
Fn208	EGBM8 <sup>#SV</sup>	EGBM7 <sup>#SV</sup>	EGBM6 <sup>#SV</sup>	EGBM5 <sup>#SV</sup>	EGBM4 <sup>#SV</sup>	EGBM3 <sup>#SV</sup>	EGBM2 <sup>#SV</sup>	EGBM1 <sup>#SV</sup>
Fn209								
Fn210	SYNMT8 <sup>#P</sup>	SYNMT7 <sup>#P</sup>	SYNMT6 <sup>#P</sup>	SYNMT5 <sup>#P</sup>	SYNMT4 <sup>#P</sup>	SYNMT3 <sup>#P</sup>	SYNMT2 <sup>#P</sup>	SYNMT1 <sup>#P</sup>
Fn211	SYNOF8 <sup>#P</sup>	SYNOF7 <sup>#P</sup>	SYNOF6 <sup>#P</sup>	SYNOF5 <sup>#P</sup>	SYNOF4 <sup>#P</sup>	SYNOF3 <sup>#P</sup>	SYNOF2 <sup>#P</sup>	SYNOF1 <sup>#P</sup>
Fn212								
Fn213								
Fn214								

Address	Bit number							
	7	6	5	4	3	2	1	0
Fn215								
Fn216								
Fn217								
Fn218								
Fn263								
Fn264	SPWRN8 <sup>#P</sup>	SPWRN7 <sup>#P</sup>	SPWRN6 <sup>#P</sup>	SPWRN5 <sup>#P</sup>	SPWRN4 <sup>#P</sup>	SPWRN3 <sup>#P</sup>	SPWRN2 <sup>#P</sup>	SPWRN1 <sup>#P</sup>
Fn265								SPWRN9 <sup>#P</sup>
Fn266	ORARD <sup>#SP</sup>	TLMD <sup>#SP</sup>	LDT2D <sup>#SP</sup>	LDT1D <sup>#SP</sup>	SARD <sup>#SP</sup>	SDTD <sup>#SP</sup>	SSTD <sup>#SP</sup>	ALMD <sup>#SP</sup>
Fn267	MORA2D <sup>#SP</sup>	MORA1D <sup>#SP</sup>	PORA2D <sup>#SP</sup>	SLVSD <sup>#SP</sup>	RCFND <sup>#SP</sup>	RCHPD <sup>#SP</sup>	CFIND <sup>#SP</sup>	CHIPD <sup>#SP</sup>
Fn268	CSYFND <sup>#SP</sup>	CS1DTD <sup>#SP</sup>					INCSTD <sup>#SP</sup>	PC1DED <sup>#SP</sup>
Fn269				CSPEND <sup>#SP</sup>				
Fn270	R08O4 <sup>#SP</sup>	R07O4 <sup>#SP</sup>	R06O4 <sup>#SP</sup>	R05O4 <sup>#SP</sup>	R04O4 <sup>#SP</sup>	R03O4 <sup>#SP</sup>	R02O4 <sup>#SP</sup>	R01O4 <sup>#SP</sup>
Fn271					R12O4 <sup>#SP</sup>	R11O4 <sup>#SP</sup>	R10O4 <sup>#SP</sup>	R09O4 <sup>#SP</sup>
Fn272	AR074 <sup>#SP</sup>	AR064 <sup>#SP</sup>	AR054 <sup>#SP</sup>	AR044 <sup>#SP</sup>	AR034 <sup>#SP</sup>	AR024 <sup>#SP</sup>	AR014 <sup>#SP</sup>	AR004 <sup>#SP</sup>
Fn273	AR154 <sup>#SP</sup>	AR144 <sup>#SP</sup>	AR134 <sup>#SP</sup>	AR124 <sup>#SP</sup>	AR114 <sup>#SP</sup>	AR104 <sup>#SP</sup>	AR094 <sup>#SP</sup>	AR084 <sup>#SP</sup>
Fn274	CSFO4 <sup>#SP</sup>	CSFO3 <sup>#SP</sup>	CSFO2 <sup>#SP</sup>	CSFO1 <sup>#SP</sup>	FCSS4 <sup>#SP</sup>	FCSS3 <sup>#SP</sup>	FCSS2 <sup>#SP</sup>	FCSS1 <sup>#SP</sup>
Fn275								
Fn276	UO023 <sup>#P</sup>	UO022 <sup>#P</sup>	UO021 <sup>#P</sup>	UO020 <sup>#P</sup>	UO019 <sup>#P</sup>	UO018 <sup>#P</sup>	UO017 <sup>#P</sup>	UO016 <sup>#P</sup>
Fn277	UO031 <sup>#P</sup>	UO030 <sup>#P</sup>	UO029 <sup>#P</sup>	UO028 <sup>#P</sup>	UO027 <sup>#P</sup>	UO026 <sup>#P</sup>	UO025 <sup>#P</sup>	UO024 <sup>#P</sup>
Fn278								
Fn279								
Fn280	UO207 <sup>#P</sup>	UO206 <sup>#P</sup>	UO205 <sup>#P</sup>	UO204 <sup>#P</sup>	UO203 <sup>#P</sup>	UO202 <sup>#P</sup>	UO201 <sup>#P</sup>	UO200 <sup>#P</sup>
Fn281	UO215 <sup>#P</sup>	UO214 <sup>#P</sup>	UO213 <sup>#P</sup>	UO212 <sup>#P</sup>	UO211 <sup>#P</sup>	UO210 <sup>#P</sup>	UO209 <sup>#P</sup>	UO208 <sup>#P</sup>
Fn282	UO223 <sup>#P</sup>	UO222 <sup>#P</sup>	UO221 <sup>#P</sup>	UO220 <sup>#P</sup>	UO219 <sup>#P</sup>	UO218 <sup>#P</sup>	UO217 <sup>#P</sup>	UO216 <sup>#P</sup>

Address	Bit number							
	7	6	5	4	3	2	1	0
Fn283	UO231 <sup>#P</sup>	UO230 <sup>#P</sup>	UO229 <sup>#P</sup>	UO228 <sup>#P</sup>	UO227 <sup>#P</sup>	UO226 <sup>#P</sup>	UO225 <sup>#P</sup>	UO224 <sup>#P</sup>
Fn284	UO307 <sup>#P</sup>	UO306 <sup>#P</sup>	UO305 <sup>#P</sup>	UO304 <sup>#P</sup>	UO303 <sup>#P</sup>	UO302 <sup>#P</sup>	UO301 <sup>#P</sup>	UO300 <sup>#P</sup>
Fn285	UO315 <sup>#P</sup>	UO314 <sup>#P</sup>	UO313 <sup>#P</sup>	UO312 <sup>#P</sup>	UO311 <sup>#P</sup>	UO310 <sup>#P</sup>	UO309 <sup>#P</sup>	UO308 <sup>#P</sup>
Fn286	UO323 <sup>#P</sup>	UO322 <sup>#P</sup>	UO321 <sup>#P</sup>	UO320 <sup>#P</sup>	UO319 <sup>#P</sup>	UO318 <sup>#P</sup>	UO317 <sup>#P</sup>	UO316 <sup>#P</sup>
Fn287	UO331 <sup>#P</sup>	UO330 <sup>#P</sup>	UO329 <sup>#P</sup>	UO328 <sup>#P</sup>	UO327 <sup>#P</sup>	UO326 <sup>#P</sup>	UO325 <sup>#P</sup>	UO324 <sup>#P</sup>
Fn288					FSPSY4 <sup>#SP</sup>	FSPSY3 <sup>#SP</sup>	FSPSY2 <sup>#SP</sup>	FSPSY1 <sup>#SP</sup>
Fn289					FSPPH4 <sup>#SP</sup>	FSPPH3 <sup>#SP</sup>	FSPPH2 <sup>#SP</sup>	FSPPH1 <sup>#SP</sup>
Fn290			PRGMD <sup>#P</sup>	PCKSV <sup>#P</sup>				
Fn291								
Fn292					ITED			
Fn293	HPS08 <sup>#P</sup>	HPS07 <sup>#P</sup>	HPS06 <sup>#P</sup>	HPS05 <sup>#P</sup>	HPS04 <sup>#P</sup>	HPS03 <sup>#P</sup>	HPS02 <sup>#P</sup>	HPS01 <sup>#P</sup>
Fn294	HPS16 <sup>#P</sup>	HPS15 <sup>#P</sup>	HPS14 <sup>#P</sup>	HPS13 <sup>#P</sup>	HPS12 <sup>#P</sup>	HPS11 <sup>#P</sup>	HPS10 <sup>#P</sup>	HPS09 <sup>#P</sup>
Fn295	CNCKYO	C2SEND						
Fn296	DM8 <sup>#SV</sup>	DM7 <sup>#SV</sup>	DM6 <sup>#SV</sup>	DM5 <sup>#SV</sup>	DM4 <sup>#SV</sup>	DM3 <sup>#SV</sup>	DM2 <sup>#SV</sup>	DM1 <sup>#SV</sup>
Fn297			MCHAO <sup>#P</sup>					MBCAN <sup>#P</sup>
Fn298								
Fn299								
Fn300								
Fn301								
Fn302								
Fn303								
Fn304								
Fn305								
Fn306								

Address	Bit number							
	7	6	5	4	3	2	1	0
Fn307								
Fn308								
Fn309								
Fn310								
Fn311								
Fn312								
Fn313								
Fn314								
Fn315	TLMEM <sup>#P</sup>	TMFNFD <sup>#P</sup>		TLMOT <sup>#P</sup>		TLMG10 <sup>#P</sup>	TLMSRH <sup>#P</sup>	TLSKF <sup>#P</sup>
Fn316	SQMPE <sup>#P</sup>	SQMPR <sup>#P</sup>						
Fn317								
Fn318								
Fn319								
Fn320								
Fn321								
Fn322								
Fn323								
Fn324								
Fn325								
Fn326								
Fn327								
Fn328	TLCHI4 <sup>#P</sup>	TLCHI3 <sup>#P</sup>	TLCHI2 <sup>#P</sup>	TLCHI1 <sup>#P</sup>	TLCH4 <sup>#P</sup>	TLCH3 <sup>#P</sup>	TLCH2 <sup>#P</sup>	TLCH1 <sup>#P</sup>
Fn329	TLCHB4 <sup>#P</sup>	TLCHB3 <sup>#P</sup>	TLCHB2 <sup>#P</sup>	TLCHB1 <sup>#P</sup>	TLSKF4 <sup>#P</sup>	TLSKF3 <sup>#P</sup>	TLSKF2 <sup>#P</sup>	TLSKF1 <sup>#P</sup>
Fn330								



Address	Bit number							
	7	6	5	4	3	2	1	0
Fn331								
Fn332								
Fn333								
Fn334								
Fn335								
Fn336								
Fn337								
Fn338								
Fn339								
Fn340								
Fn341	SYCM8 <sup>#SV</sup>	SYCM7 <sup>#SV</sup>	SYCM6 <sup>#SV</sup>	SYCM5 <sup>#SV</sup>	SYCM4 <sup>#SV</sup>	SYCM3 <sup>#SV</sup>	SYCM2 <sup>#SV</sup>	SYCM1 <sup>#SV</sup>
Fn342	SYCS8 <sup>#SV</sup>	SYCS7 <sup>#SV</sup>	SYCS6 <sup>#SV</sup>	SYCS5 <sup>#SV</sup>	SYCS4 <sup>#SV</sup>	SYCS3 <sup>#SV</sup>	SYCS2 <sup>#SV</sup>	SYCS1 <sup>#SV</sup>
Fn343	MIXO8 <sup>#SV</sup>	MIXO7 <sup>#SV</sup>	MIXO6 <sup>#SV</sup>	MIXO5 <sup>#SV</sup>	MIXO4 <sup>#SV</sup>	MIXO3 <sup>#SV</sup>	MIXO2 <sup>#SV</sup>	MIXO1 <sup>#SV</sup>
Fn344	OVMO8 <sup>#SV</sup>	OVMO7 <sup>#SV</sup>	OVMO6 <sup>#SV</sup>	OVMO5 <sup>#SV</sup>	OVMO4 <sup>#SV</sup>	OVMO3 <sup>#SV</sup>	OVMO2 <sup>#SV</sup>	OVMO1 <sup>#SV</sup>
Fn345	OVS08 <sup>#SV</sup>	OVS07 <sup>#SV</sup>	OVS06 <sup>#SV</sup>	OVS05 <sup>#SV</sup>	OVS04 <sup>#SV</sup>	OVS03 <sup>#SV</sup>	OVS02 <sup>#SV</sup>	OVS01 <sup>#SV</sup>
Fn346	SMPK8 <sup>#SV</sup>	SMPK7 <sup>#SV</sup>	SMPK6 <sup>#SV</sup>	SMPK5 <sup>#SV</sup>	SMPK4 <sup>#SV</sup>	SMPK3 <sup>#SV</sup>	SMPK2 <sup>#SV</sup>	SMPK1 <sup>#SV</sup>
Fn347	D3MI <sup>#P</sup>							
Fn348								
Fn349								
Fn350								
Fn356							THREND <sup>#P</sup>	MTHML <sup>#P</sup>
Fn358	WPSF8	WPSF7	WPSF6	WPSF5	WPSF4	WPSF3	WPSF2	WPSF1
~								
Fn376	SVSST8 <sup>#SV</sup>	SVSST7 <sup>#SV</sup>	SVSST6 <sup>#SV</sup>	SVSST5 <sup>#SV</sup>	SVSST4 <sup>#SV</sup>	SVSST3 <sup>#SV</sup>	SVSST2 <sup>#SV</sup>	SVSST1 <sup>#SV</sup>

Address	Bit number							
	7	6	5	4	3	2	1	0
Fn377	SVSAR8 <sup>#SV</sup>	SVSAR7 <sup>#SV</sup>	SVSAR6 <sup>#SV</sup>	SVSAR5 <sup>#SV</sup>	SVSAR4 <sup>#SV</sup>	SVSAR3 <sup>#SV</sup>	SVSAR2 <sup>#SV</sup>	SVSAR1 <sup>#SV</sup>
~								
Fn395								
Fn396								
Fn397								
Fn398								
Fn399								
Fn400					SUCLPD <sup>#SP</sup>	SUCLPC <sup>#SP</sup>	SUCLPB <sup>#SP</sup>	
Fn401					SCLPD <sup>#SP</sup>	SCLPC <sup>#SP</sup>	SCLPB <sup>#SP</sup>	
Fn402					MSPD <sup>#SP</sup>	MSPC <sup>#SP</sup>	MSPB <sup>#SP</sup>	
Fn403								SYNER <sup>#P</sup>
Fn404							COSP4 <sup>#P</sup>	COSP3 <sup>#P</sup>
Fn405								
Fn406								
Fn407								
Fn408								
Fn409								
Fn410								
Fn411								
Fn412								
Fn413								
Fn414								
Fn415								
Fn416								

Address	Bit number							
	7	6	5	4	3	2	1	0
Fn417								
Fn418								
~								
Fn511								
Fn512						MCSP <sup>#P</sup>	MCRQ <sup>#P</sup>	MCEXE <sup>#P</sup>
Fn513	ZRNR <sup>#P</sup>		DNCIR <sup>#P</sup>			MD4R <sup>#P</sup>	MD2R <sup>#P</sup>	MD1R <sup>#P</sup>
Fn514	MCEX8 <sup>#P</sup>	MCEX7 <sup>#P</sup>	MCEX6 <sup>#P</sup>	MCEX5 <sup>#P</sup>	MCEX4 <sup>#P</sup>	MCEX3 <sup>#P</sup>	MCEX2 <sup>#P</sup>	MCEX1 <sup>#P</sup>
Fn515	MCEX16 <sup>#P</sup>	MCEX15 <sup>#P</sup>	MCEX14 <sup>#P</sup>	MCEX13 <sup>#P</sup>	MCEX12 <sup>#P</sup>	MCEX11 <sup>#P</sup>	MCEX10 <sup>#P</sup>	MCEX9 <sup>#P</sup>
Fn516	MSEMI8 <sup>#SV</sup>	MSEMI7 <sup>#SV</sup>	MSEMI6 <sup>#SV</sup>	MSEMI5 <sup>#SV</sup>	MSEMI4 <sup>#SV</sup>	MSEMI3 <sup>#SV</sup>	MSEMI2 <sup>#SV</sup>	MSEMI1 <sup>#SV</sup>
Fn517	RP18 <sup>#SV</sup>	RP17 <sup>#SV</sup>	RP16 <sup>#SV</sup>	RP15 <sup>#SV</sup>	RP14 <sup>#SV</sup>	RP13 <sup>#SV</sup>	RP12 <sup>#SV</sup>	RP11 <sup>#SV</sup>
Fn518	RP28 <sup>#SV</sup>	RP27 <sup>#SV</sup>	RP26 <sup>#SV</sup>	RP25 <sup>#SV</sup>	RP24 <sup>#SV</sup>	RP23 <sup>#SV</sup>	RP22 <sup>#SV</sup>	RP21 <sup>#SV</sup>
Fn519	PTOFS <sup>#P</sup>	PTRDY <sup>#P</sup>	PTCVA <sup>#P</sup>	PTCNV <sup>#P</sup>	PTMOD <sup>#P</sup>			
Fn520					ACDEC <sup>#P</sup>			ATBK
Fn521	SVREV8	SVREV7	SVREV6	SVREV5	SVREV4	SVREV3	SVREV2	SVREV1
Fn522	SPP8	SPP7	SPP6	SPP5	SPP4	SPP3	SPP2	SPP1
Fn523								
Fn524								
Fn525	SSYO4 <sup>#SP</sup>	SSYO3 <sup>#SP</sup>	SSYO2 <sup>#SP</sup>	SSYO1 <sup>#SP</sup>	SGNO4 <sup>#SP</sup>	SGNO3 <sup>#SP</sup>	SGNO2 <sup>#SP</sup>	SGNO1 <sup>#SP</sup>
~								
Fn531			TDIACK	TDICLK	MMDISL			
Fn532	SYNO8 <sup>#SV</sup>	SYNO7 <sup>#SV</sup>	SYNO6 <sup>#SV</sup>	SYNO5 <sup>#SV</sup>	SYNO4 <sup>#SV</sup>	SYNO3 <sup>#SV</sup>	SYNO2 <sup>#SV</sup>	SYNO1 <sup>#SV</sup>
Fn533								
Fn534								
Fn535	WFLN2	WFLN1	WETF	WETE	WECCS	WIOCH3	WIOCH2	WIOCH1
Fn540	TDIH4FE	TDIH3FE	TDIH2FE	TDIH1FE	TDIT4FE	TDIT3FE	TDIT2FE	TDIT1FE

Address	Bit number							
	7	6	5	4	3	2	1	0
Fn541			TDIO6FE	TDIO5FE	TDIO4FE	TDIO3FE	TDIO2FE	TDIO1FE
Fn542	TDIH4AE	TDIH3AE	TDIH2AE	TDIH1AE	TDIT4AE	TDIT3AE	TDIT2AE	TDIT1AE
Fn543			TDIO6AE	TDIO5AE	TDIO4AE	TDIO3AE	TDIO2AE	TDIO1AE
~								
Fn545							OVLNS <sup>#P</sup>	
Fn546					CSMC4 <sup>#SP</sup>	CSMC3 <sup>#SP</sup>	CSMC2 <sup>#SP</sup>	CSMC1 <sup>#SP</sup>
~								
Fn553					PHERD <sup>#P</sup>	PHERC <sup>#P</sup>	PHERB <sup>#P</sup>	PHERA <sup>#P</sup>
~								
Fn767								

# 7 EMBEDDED ETHERNET FUNCTION

This chapter describes the specifications of the embedded Ethernet function.

Chapter 8, "EMBEDDED ETHERNET FUNCTION", consists of the following sections:

7.1	EMBEDDED ETHERNET PORT AND PCMCIA ETHERNET CARD .....	435
7.2	SETTING UP THE EMBEDDED ETHERNET FUNCTION .....	437
7.3	SWITCHING BETWEEN THE EMBEDDED ETHERNET DEVICES .....	466
7.4	EMBEDDED ETHERNET OPERATIONS .....	466
7.5	RESTART OF THE EMBEDDED ETHERNET .....	470
7.6	MAINTENANCE SCREEN FOR EMBEDDED ETHERNET FUNCTION.....	471
7.7	LOG SCREEN OF THE EMBEDDED ETHERNET FUNCTION.....	474

## 7.1 EMBEDDED ETHERNET PORT AND PCMCIA ETHERNET CARD

The embedded Ethernet function can be used by selecting one of two types of devices: the embedded Ethernet port and PCMCIA Ethernet card.

A selection can also be made to stop the embedded Ethernet function.

The PCMCIA Ethernet card is to be inserted into the memory card slot for temporary communication.

### CAUTION

- 1 When using the embedded Ethernet function for the first time, set an IP address and other items carefully as instructed by the network administrator, then perform a sufficient communication test.  
Note that an incorrect IP address or other setting may cause a communication failure on the entire network.
- 2 A unit such as a PC situated in the same network can increase the communication processing load on the CNC even if the unit is not communicating with the CNC.  
Avoid connecting the CNC to a factory-wide network. Use a router or the like to separate the network including the CNC from the other networks.

### NOTE

- 1 The embedded Ethernet port of Series 32i is available as an option.
- 2 Use the PCMCIA Ethernet card designated by FANUC. General Ethernet cards available on the market cannot be used.
- 3 The PCMCIA Ethernet card is used for FANUC LADDER-III or SERVO GUIDE.
- 4 Use the PCMCIA Ethernet card just for temporary communication as described above. Avoid using the card for continuous communication.
- 5 The PCMCIA Ethernet card is inserted into a memory card slot, with a part of the card left uninserted. When using the PCMCIA Ethernet card, take great care not to damage the card by hitting the protruding part of the card.  
When the card becomes unnecessary, remove the card immediately, in order to prevent any damage to the card.

---

**Related NC parameters**

---

	#7	#6	#5	#4	#3	#2	#1	#0
14880								ETH

[Input type] Parameter input

[Data type] Bit

- #0 ETH** The embedded Ethernet function (embedded Ethernet port or PCMCIA Ethernet card) is:
- 0: Used.
  - 1: Not used.

**NOTE**

When this parameter is set, the power must be turned off before operation is continued.

14896
-------

Selection of embedded Ethernet with the stand-alone type Series 30i /31i /32i with display unit with Windows CE
---

**NOTE**

When this parameter is set, the power must be turned off before operation is continued.

[Input type] Parameter input

[Data type] Word

[Valid data range] 0 to 3

Set embedded Ethernet usable with the stand-alone type Series 30i /31i /32i with display unit with Windows CE.

- 0 : For the embedded Ethernet port, the connector (CD38A) for Ethernet on the control unit is used.

For the PCMCIA Ethernet card, the card slot on the side of the display unit is used.

- 1 : For the embedded Ethernet port, the connector (CD38A) for Ethernet on the control unit is used.

For the PCMCIA Ethernet card, the card slot (CNM1B) on the control unit is used.

- 2 : For the embedded Ethernet port, the connector (CD38S) for Ethernet on the rear of the display unit is used.

For the PCMCIA Ethernet card, the card slot on the side of the display unit is used.

- 3 : For the embedded Ethernet port, the connector (CD38S) for Ethernet on the rear of the display unit is used.

For the PCMCIA Ethernet card, the card slot (CNM1B) on the control unit is used.

No.14896	embedded Ethernet port	PCMCIA Ethernet card
0	Port in the CNC	Memory card slot on a side of the display unit
1	Port in the CNC	Memory card slot in the CNC
2	Port in the rear of the display unit	Memory card slot on a side of the display unit
3	Port in the rear of the display unit	Memory card slot in the CNC

---

**Notes on using Ethernet with display unit with Windows CE**

---

The Ethernet interface on display unit with Windows CE may be used by both of the embedded Ethernet function of the CNC and application software on Windows CE.

Note that the restrictions below are imposed accordingly.

**NOTE**

- 1 When the LCD-mounted type Series 30i /31i /32i with Windows CE is used and the PCMCIA Ethernet card is selected for the embedded Ethernet function, application software on Windows CE cannot use the embedded Ethernet port. When the embedded Ethernet port is selected for the embedded Ethernet function, application software on Windows CE cannot use the PCMCIA Ethernet card.
- 2 When the stand-alone type Series 30i /31i /32i with display unit with Windows CE is used, the connection location of the embedded Ethernet function varies according to the setting of NC parameter No. 14896. So, the restrictions below are applied to the Ethernet interface on Windows CE.
  - (1) When 0 is set in NC parameter No. 14896 and the PCMCIA Ethernet card is selected for the embedded Ethernet function, application software on Windows CE cannot use the embedded Ethernet port.
  - (2) When 1 is set in NC parameter No. 14896, application software on Windows CE can use the embedded Ethernet port and PCMCIA Ethernet card.
  - (3) When 2 is set in NC parameter No. 14896, the restriction on item 1 above (for the LCD-mounted type) is applied.
  - (4) When 3 is set in NC parameter No. 14896 and the embedded Ethernet port is selected for the embedded Ethernet function, application software on Windows CE cannot use the PCMCIA Ethernet card.
- 3 When the Series 30i /31i /32i with Windows CE is used, application software on Windows CE can perform communication simultaneously on a port (embedded Ethernet port or PCMCIA Ethernet card) selected for the embedded Ethernet function.

## 7.2 SETTING UP THE EMBEDDED ETHERNET FUNCTION

This section describes the setting of parameters for the embedded Ethernet function.

### 7.2.1 Setting of the FOCAS2/Ethernet Function

This subsection describes the settings required to operate the FOCAS2/Ethernet function.

#### Notes on using the FOCAS2/Ethernet function for the first time

**NOTE**

- 1 When running user's original application software created by using the FOCAS2/Ethernet function, use the embedded Ethernet port.
- 2 The FOCAS2/Ethernet function allows up to five FOCAS2/Ethernet clients to be connected to one CNC.
- 3 Concurrent access by multiple applications or personal computers may overload the CNC, reducing the communication speed.

### 7.2.1.1 Operation on the FOCAS2/Ethernet setting screen

On the Ethernet parameter setting screen, set the parameters for operating the FOCAS2/Ethernet function.

#### Procedure

- 1 Press the function key .
- 2 Soft keys [EMBED PORT] and [PCMCIA LAN] appear.  
(When there is no soft keys, press the continue key.)
- 3 To display the Ethernet Setting screen for the embedded Ethernet port or the PCMCIA Ethernet card, press soft key [EMBED PORT] or [PCMCIA LAN], respectively.
- 4 Press soft keys [COMMON] and [FOCAS2] and then enter parameters for the items that appear.

#### NOTE

- 1 The parameters for the embedded Ethernet port and the parameters for the PCMCIA Ethernet card are independent of each other.
- 2 The settings of the FOCAS2/Ethernet function for the PCMCIA Ethernet card are made when a connection to SERVO GUIDE and FANUC LADDER-III is established.

#### COMMON screen (BASIC)

Press soft key [COMMON]. The COMMON screen (BASIC) is displayed.

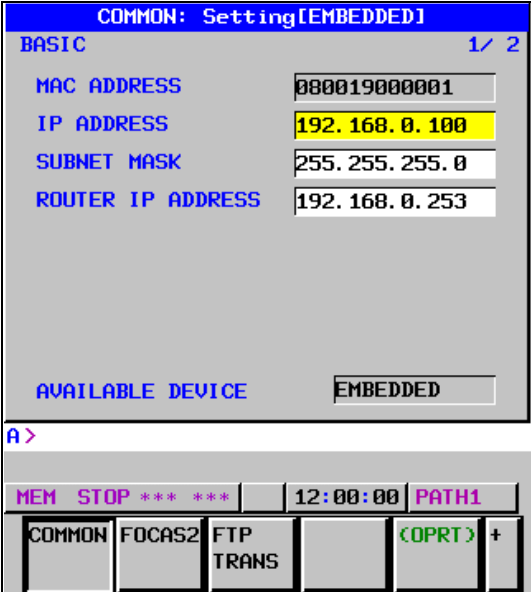

COMMON: Setting [EMBEDDED]  
 BASIC 1 / 2  
 MAC ADDRESS 080019000001  
 IP ADDRESS 192.168.0.100  
 SUBNET MASK 255.255.255.0  
 ROUTER IP ADDRESS 192.168.0.253  
 AVAILABLE DEVICE EMBEDDED  
 A >  
 MEM STOP \*\*\* \*\* 12:00:00 PATH1  
 COMMON FOCAS2 FTP TRANS (OPRT) +

COMMON screen (BASIC)

#### Setting items

Item	Description
IP ADDRESS	Specify the IP address of the embedded Ethernet. (Example of specification format: "192.168.0.100")
SUBNET MASK	Specify a mask address for the IP addresses of the network. (Example of specification format: "255.255.255.0")
ROUTER IP ADDRESS	Specify the IP address of the router. Specify this item when the network contains a router. (Example of specification format: "192.168.0.253")



## Display items

Item	Description
MAC ADDRESS	Embedded Ethernet MAC address
AVAILABLE DEVICE	Enabled device of the embedded Ethernet. Either the embedded Ethernet port or the PCMCIA Ethernet card is displayed.

## FOCAS2 screen

Press soft key [FOCAS2]. The FOCAS2 screen is displayed.

```

FOCAS2/Ethernet: Setting [EMBEDDED]
BASIC
PORT NUMBER (TCP)      8193
PORT NUMBER (UDP)      0
TIME INTERVAL          0

AVAILABLE DEVICE      EMBEDDED

A >
MEM STOP *** **      12:00:00  PATH1
COMMON FOCAS2 FTP TRANS (OPRT) +
  
```

FOCAS2 screen

## Setting items

Item	Description
PORT NUMBER (TCP)	Specify a port number to be used with the FOCAS2/Ethernet function. The valid input range is 5001 to 65535.
PORT NUMBER (UDP)	Set this item to 0 when it is used as the FOCAS2/Ethernet function.
TIME INTERVAL	Set this item to 0 when it is used as the FOCAS2/Ethernet function.

## Initial setting of the PCMCIA Ethernet card

The PCMCIA Ethernet card is factory-set to the following standard setting values, for ease of connection with SERVO GUIDE or FANUC LADDER-III.

```

IP ADDRESS           : 192.168.1.1
SUBNET MASK          : 255.255.255.0
ROUTER IP ADDRESS    : None
PORT NUMBER (TCP)    : 8193
PORT NUMBER (UDP)    : 0
TIME INTERVAL        : 0
  
```

If a specified IP address is changed to a blank (space), the specified setting is reset to the standard setting value.

The embedded Ethernet port does not have a standard setting value.

### 7.2.1.2 Example of setting the FOCAS2/Ethernet function

The following shows a setting example required for the FOCAS2/Ethernet function to operate. In this example, one personal computer is connected to two CNCs through FOCAS2/Ethernet.

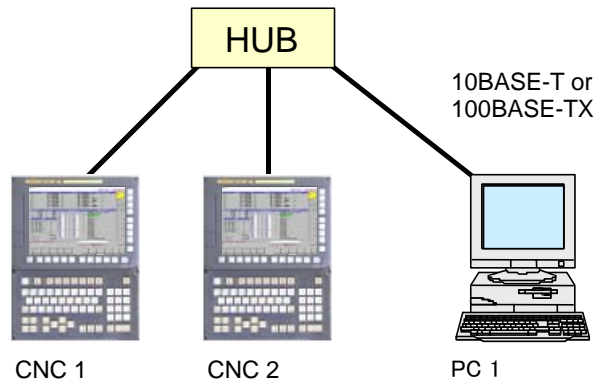

	CNC 1	CNC 2
IP address	192.168.0.100	192.168.0.101
Subnet mask	255.255.255.0	255.255.255.0
Router IP address	None	None
TCP port number	8193	8193
UDP port number	0	0
Time interval	0	0

The Ethernet parameter screen is used for setting.

		PC 1
IP address		192.168.0.200
Subnet mask		255.255.255.0
Default gateway		None
CNC 1	NC IP address	192.168.0.100
	NC TCP port number	8193
CNC 2	NC IP address	192.168.0.101
	NC TCP port number	8193

"Microsoft TCP/IP property" of the personal computer (Windows2000/ XP/ Vista) is used for setting.

The arguments of the data window library function `cnc_allclibhnd3` are used for setting.

### 7.2.2 Setting of the FTP File Transfer Function

This section describes the settings required for the FTP file transfer function to operate using the embedded Ethernet function.

#### Notes on using the FTP file transfer function for the first time

##### NOTE

- 1 When using the FTP file transfer function, use the embedded Ethernet port.
- 2 The number of FTP communications to which one CNC can be connected using the FTP file transfer function is one.

### 7.2.2.1 Operation on the FTP file transfer setting screen

On the Ethernet setting screen, set the parameters for operating the FTP file transfer function.

#### Procedure

- 1 Press the function key .
- 2 Soft keys [EMBED PORT] appear.  
(When there is no soft keys, press the continue key.)
- 3 By pressing the [EMBED PORT] soft key, the Ethernet Setting screen for the embedded Ethernet port is displayed.
- 4 Press soft keys [COMMON] and [FTP TRANS] and then enter parameters for the items that appear.

#### NOTE

The parameters for the embedded Ethernet port and the parameters for the PCMCIA Ethernet card are independent of each other.  
If the [PCMCIA LAN] soft key is pressed, the PCMCIA Ethernet card can be set up. However, the card setup is carried out for maintenance and is not necessary usually.

#### COMMON screen (BASIC)

Press soft key [COMMON]. The COMMON screen (BASIC) is displayed.

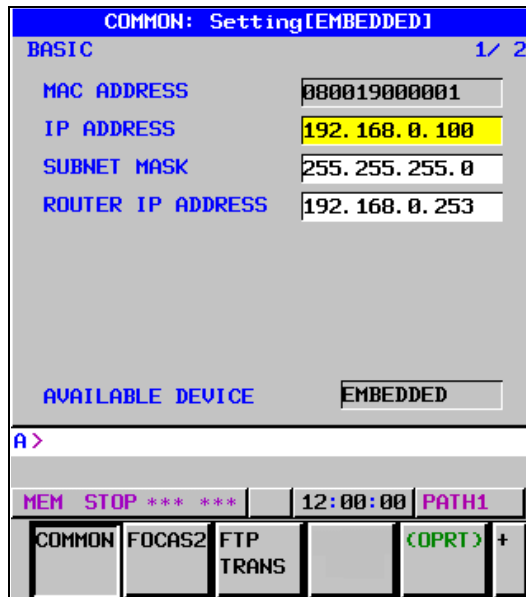

COMMON screen (BASIC)

#### Setting items

Item	Description
IP ADDRESS	Specify the IP address of the embedded Ethernet. (Example of specification format: "192.168.0.100")
SUBNET MASK	Specify a mask address for the IP addresses of the network. (Example of specification format: "255.255.255.0")
ROUTER IP ADDRESS	Specify the IP address of the router. Specify this item when the network contains a router. (Example of specification format: "192.168.0.253")

**Display items**

Item	Description
MAC ADDRESS	Embedded Ethernet MAC address
AVAILABLE DEVICE	Enabled device of the embedded Ethernet. Either the embedded Ethernet port or the PCMCIA Ethernet card is displayed.

**transfer screen (CONNECT1, CONNECT2, CONNECT3)**

- 1 Press soft key [FTP TRANS]. The FTP transfer screen is displayed.
- 2 Page keys  can be used to make settings for the three host computers for connection destinations 1 to 3.

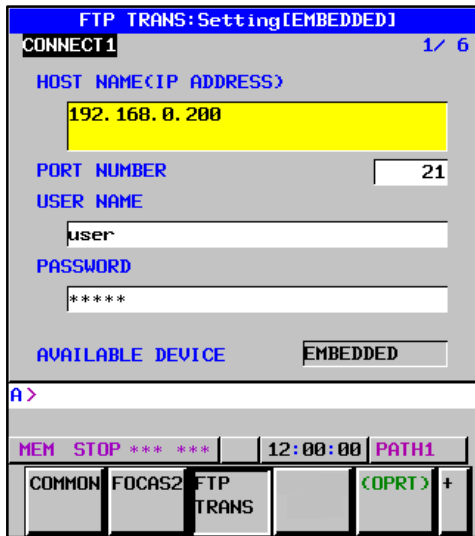

FTP transfer screen (1st page)

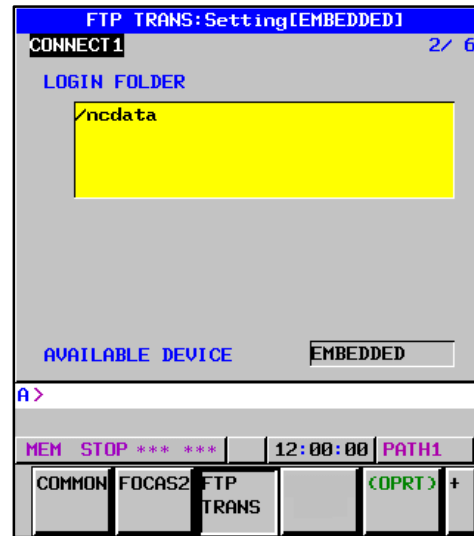

FTP transfer screen (2nd page)

**Setting items**

Item	Description
HOST NAME	Specify the IP address of the host computer. (Example of specification format: "192.168.0.200")
PORT NUMBER	Specify a port number to be used with the FTP file transfer function. An FTP session is used, so that "21" is to be specified usually.
USERNAME	Specify a user name to be used for logging in to the host computer with FTP. (Up to 31 characters can be specified.)
PASSWORD	Specify a password for the user name specified above. (Up to 31 characters can be specified.) Be sure to set a password.
LOGIN FOLDER	Specify a work folder to be used when logging in to the host computer. (Up to 127 characters can be specified.) If nothing is specified, the home folder specified in the host computer becomes the log-in folder.

**Operation**

Select a destination.

- 1 Pressing the [<OPRT>] soft key causes soft key [HOST SELECT] to be displayed. Pressing this soft key causes soft keys [CONNECT 1], [CONNECT 2], and [CONNECT 3] to be displayed.



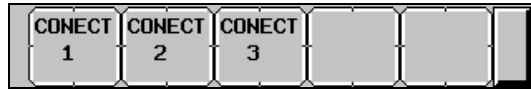

- Depending on the host computer to be connected, press soft key [CONNECT 1], [CONNECT 2], or [CONNECT 3]. Destination 1, 2, or 3 is highlighted in the screen title field. The computer corresponding to the highlighted destination is selected as the target computer to be connected.

**CONNECT 1** → **CONNECT 1**

When destination 1 is selected

### 7.2.2.2 Related NC parameters

The NC parameters related to the FTP file transfer function are described below.

0020	I/O CHANNEL : Input/output device selection, or interface number for a foreground input device
------	--

[Data type] Byte

[Valid data range] 9 : Select the embedded Ethernet as the input/output device.

#### For embedded Ethernet port

	#7	#6	#5	#4	#3	#2	#1	#0
14880							PCH	

[Input type] Parameter input

[Data type] Bit

- #1 PCH** When communication based on the FTP file transfer function starts, an FTP server presence check based on PING is:  
 0: Made  
 1: Not made

**NOTE**  
 Usually, set this parameter to 0 (to make a check).  
 If this parameter is set to 1 (not to make an FTP server presence check based on PING), several tens of seconds may be required until an error is recognized when no FTP server is present on the network.  
 Mainly for security, a personal computer may be set to ignore the PING command. When communicating with such a personal computer, set this parameter to 1 (not to make an FTP server presence check based on PING).

### 7.2.2.3 Example of setting the FTP file transfer function

The following shows a setting example required for the FTP file transfer function to operate. (The OS used on the PC in the example is Windows XP Professional.)

In this example, one personal computer is connected to two CNCs through the FTP file transfer function.

- On Personal Computer 1, the FTP server function operates.
- On CNC 1 and CNC 2, the FTP client operates as the FTP file transfer function.

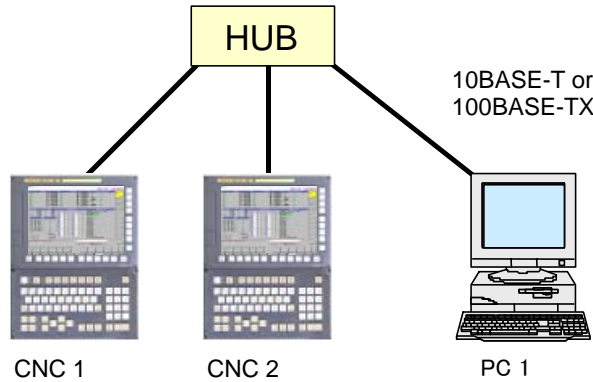

		CNC 1	CNC 2
IP address		192.168.0.100	192.168.0.101
Subnet mask		255.255.255.0	255.255.255.0
Router IP address		None	None
Connection host 1	Port number	21	21
	IP address	192.168.0.200	192.168.0.200
	User name	user	user
	Password	user	user
	Login DIR	None	None
NC parameter No. 20		9	9

The Ethernet parameter screen is used for setting.

The parameter screen is used for setting.

		PC 1
IP address		192.168.0.200
Subnet mask		255.255.255.0
Default gateway		None
User name		user
Password		user
Login DIR		Default

"Microsoft TCP/IP property" of the personal computer (WindowsXP) is used for setting.

"User account" of the personal computer (WindowsXP) is used for setting.

"Internet service manager" of the personal computer (WindowsXP) is used for setting.

### 7.2.3 Setting Up the DNS/DHCP Function

The DHCP/DNS function is set up by using the COMMON screen (DETAIL) and NC parameters.



#### 7.2.3.1 Setting up DNS

This subsection describes the procedure for setting up a DNS.

##### Procedure

- 1 Enable the DNS client function, with reference to "Related NC Parameters," which will be seen later.
- 2 Set up the DNS server of the host computer.
- 3 Connect the host computer on which the DNS server is working (hereafter referred to as a DNS server), reboot the CNC, then press function key .
- 4 Press soft keys [EMBED PORT] and [COMMON] in that order. The COMMON screen (DETAIL) appears.
- 5 Enter the IP address of the DNS server in the corresponding DNS IP address field.

**COMMON screen (DETAIL)**

After pressing soft key [COMMON], press either page key   to call a desired COMMON screen (DETAIL). Specify a DNS IP address.

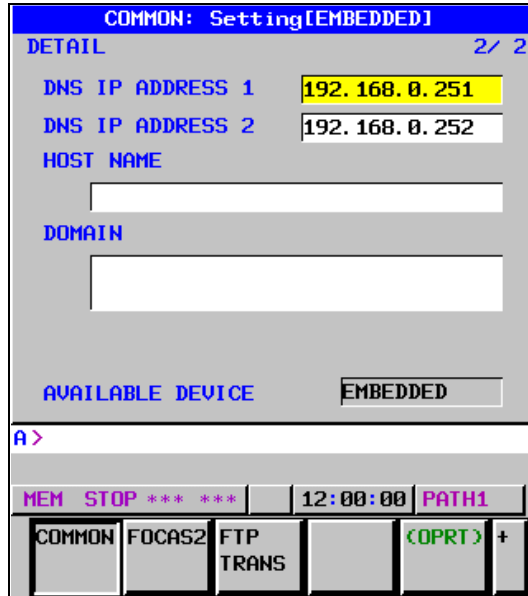

COMMON screen (DETAIL)

**Setting items**

Item	Description
DNS IP ADDRESS 1, 2	Up to two DNS IP addresses can be specified. The CNC searches for the DNS server using DNS IP addresses 1 and 2 in that order.



**7.2.3.2 Setting up DHCP**

This subsection describes the procedure for setting up a DHCP.

**Procedure**

- 1 Enable the DHCP client function, with reference to "Related NC Parameters," which will be seen later.
- 2 Set up the DHCP server of the host computer.
- 3 Connect the host computer on which the DHCP server is working (hereafter referred to as a DHCP server), reboot the CNC, then press function key .
- 4 Press soft keys [EMBED PORT] and [COMMON] in that order. The COMMON screen appears.
- 5 If the DHCP client function of the CNC has been enabled and if the DHCP server is connected successfully, the DHCP server automatically specifies the following items.
  - IP ADDRESS
  - SUBNET MASK
  - ROUTER IP ADDRESS
  - DNS IP ADDRESS
  - DOMAIN
 If the DHCP server cannot be connected, "DHCP ERROR" is displayed in each field.
- 6 If the DNS client function has also been enabled and if the DHCP server and the DNS server work together (if the DNS server supports dynamic DNS), enter a host name.

**COMMON screen (BASIC and DETAIL)**

After pressing soft key [COMMON], press either page key   to call a desired Ethernet common setting screens (BASIC and DETAIL).

If the DHCP server is connected successfully and if the setting data can be obtained, the screens are displayed as shown below.

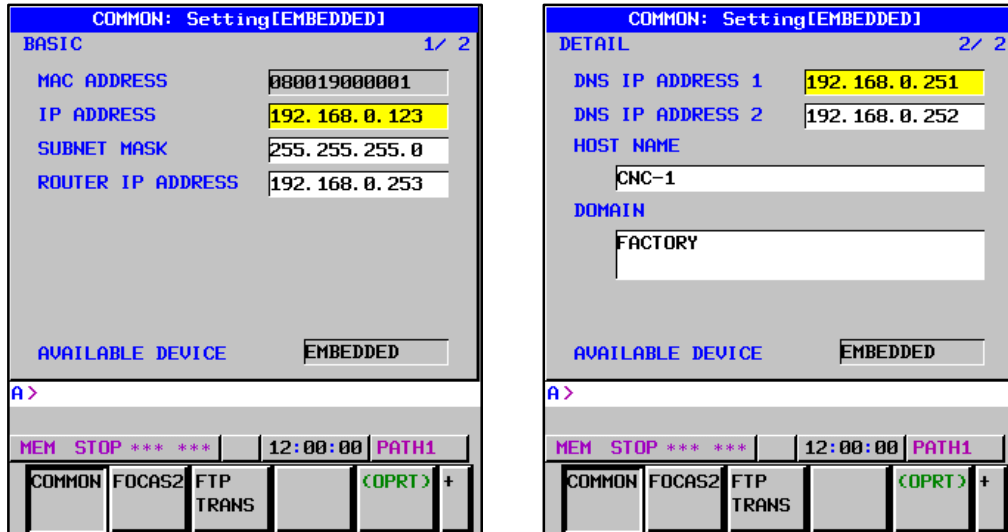

When the DHCP server is connected successfully

If the host name is not specified, the CNC automatically assigns a host name in the "NC-<MAC-address>" format.

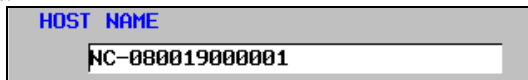

Example of automatically assigned host name

If the DHCP server cannot be connected, the screens are displayed as shown below.

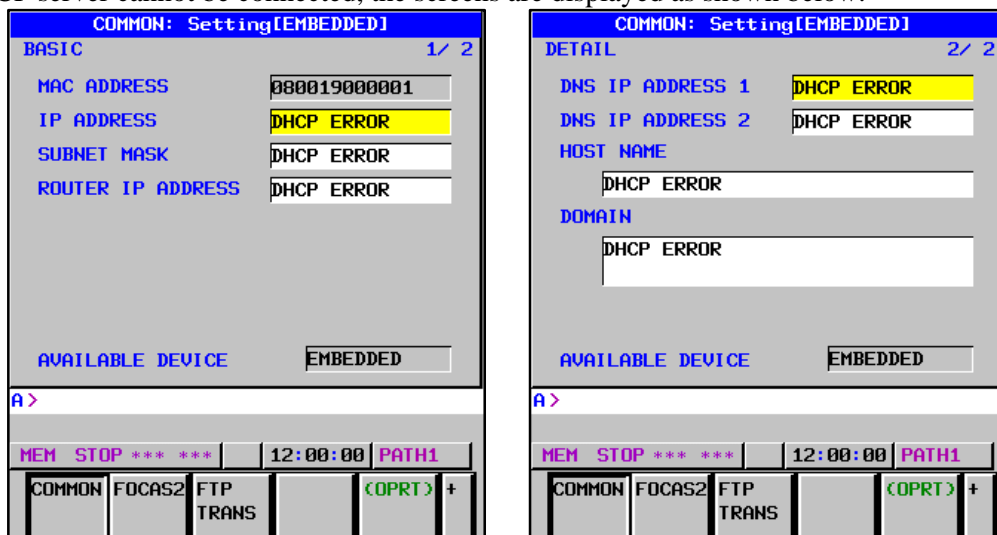

When the DHCP server cannot be connected



**Check items**

Item	Description
IP ADDRESS	If the DHCP server is connected successfully, the items obtained from the DHCP server are displayed. If the DHCP server cannot be connected, "DHCP ERROR" is displayed.
SUBNET MASK	
ROUTER IP ADDRESS	
DNS IP ADDRESS 1,2	
DOMAIN	

**Setting items**

Item	Description
HOST NAME	Enter the host name of the CNC. If a DHCP server and a DNS server work together, the DHCP server notifies the DNS server of this host name. If the host name is left blank, a host name is automatically assigned in the "NC-<MAC-address>" format. Example of automatically assigned host name: NC-080019000001

**Display items**

Item	Description
MAC ADDRESS	MAC address of embedded Ethernet

**7.2.3.3 Related NC parameters****For embedded Ethernet port**

	#7	#6	#5	#4	#3	#2	#1	#0
14880		DHC	DNS					

**NOTE**

Re-setting this parameter requires turning the power off and on again or restarting the embedded Ethernet interface.

[Input type] Parameter input

[Data type] Bit

**#5 DNS** With the embedded Ethernet port, the DHCP function is:

0: Used.

1: Not used.

**#6 DHC** With the embedded Ethernet port, the DHCP function is:

0: Used.

1: Not used.

A change in these parameters becomes effective after the power is turned off and on or after the embedded Ethernet function is restarted.

## 7.2.4 Setting of the Unsolicited Messaging Function

This subsection describes the setting required to operate the unsolicited messaging function with the embedded Ethernet function.

### NOTE

To use the unsolicited messaging function with the embedded Ethernet port, the enhanced embedded Ethernet function (-R952) is required.

### 7.2.4.1 Overview

This subsection provides an overview of the unsolicited messaging function and describes the execution procedure.

#### Overview of the unsolicited messaging function

An overview of the unsolicited messaging function is provided below.

With the unsolicited messaging function, the CNC transmits messages (CNC/PMC data) in an unsolicited manner to application software on the personal computer according to a command from an NC program or ladder program. By using this function, the need for application processing on the personal computer to periodically inquire about the state of the CNC can be eliminated.

#### When the conventional function is used

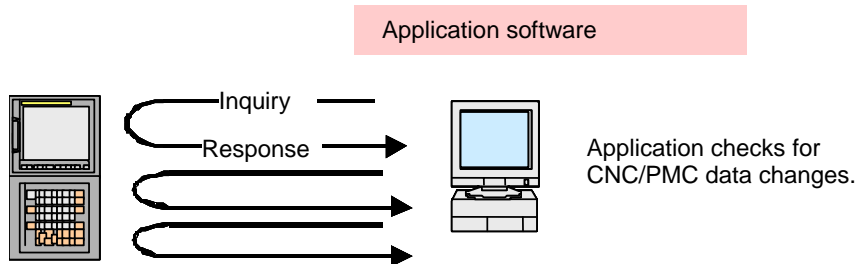

#### When the unsolicited messaging function is used

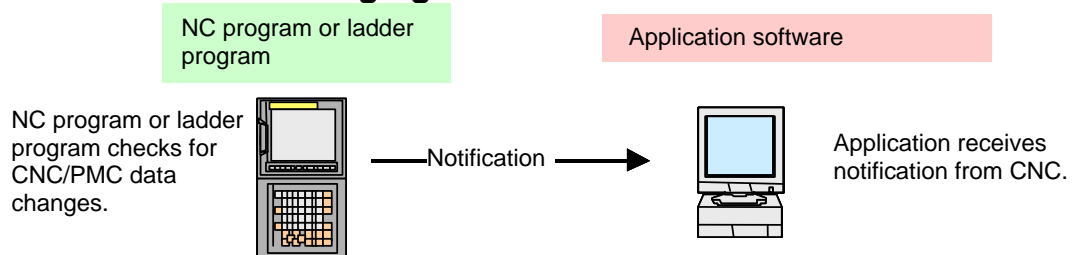

### NOTE

The unsolicited messaging function is a part of the FOCAS2/Ethernet function.

## Unsolicited messaging function execution procedure

The execution procedure for the unsolicited messaging function is described below.

### 1 Preparation on the personal compute

Create an application using the FOCAS2 function for the unsolicited messaging function and install the unsolicited message server on a personal computer. For the method of creating an application using the FOCAS2 function for the unsolicited messaging function and the method of installing the unsolicited message server, refer to Chapter 5, "Unsolicited Messaging Function", in the "Data Window Library Specifications" supplied with the FOCAS1/2 library.

### 2 Preparation on the CNC

Create an NC program or ladder program for controlling unsolicited messaging.

For the method of creating an NC program or ladder program, see Subsection 7.2.4.6, "Execution methods".

### 3 Setting of the communication parameters for the unsolicited messaging function

To use the unsolicited messaging function, the following communication parameter settings are needed:

- (1) Setting for using the FOCAS2/Ethernet function
- (2) Setting of the parameters for the unsolicited messaging function

For (2), a choice can be made from two modes of setting: CNC mode for setting on the CNC screen and the PC mode for setting on the personal computer.

For the setting method of (1) and (2), see Subsection 7.2.4.2, "Setting of the FOCAS2/Ethernet function" through Subsection 7.2.4.5, "Setting on the personal computer".

### 4 Starting the NC program or ladder program

Start the NC program or ladder program created in step 2, "Preparation on the CNC". At this time, no unsolicited message is transmitted to the personal computer until step 5, "Starting the unsolicited messaging function", is executed.

### 5 Starting the unsolicited messaging function

Execute the FOCAS2 function `cnc_unsolicstart` on the personal computer. This execution places the CNC in the state (named "Ready") where a transmission request from the NC program or ladder program is awaited. Each time a transmission request is made from the NC program or ladder program, an unsolicited message is automatically transmitted to the personal computer.

### 6 Ending the unsolicited messaging function

To end unsolicited message transmission, execute the FOCAS2 function `cnc_unsolicstop` on the personal computer. This execution places the CNC in the state (named "Not Ready") where no unsolicited message is transmitted even when a request for transmission is made from the NC program or ladder program.

## 7.2.4.2 Setting of the FOCAS2/Ethernet function

This subsection describes the setting of the FOCAS2/Ethernet function for operating the unsolicited messaging function.

### Procedure

- 1 Enable the unsolicited messaging function according to "Related NC parameters" described later.
- 2 Start the CNC again then press function key .
- 3 Soft key [EMBED PORT] is displayed. (Press the continuous menu key until the soft key is displayed.)
- 4 Press soft key [EMBED PORT]. The Ethernet Setting screen for the embedded Ethernet port is displayed.
- 5 Press soft keys [COMMON] and [FOCAS2] then make settings on each screen.
- 6 Press soft key [UNSOLI MSG]. The Unsolicited Message screen is displayed. (Press the continuous menu key until the soft key [UNSOLI MSG] is displayed.) For details of the Unsolicited Message screen, see Subsections starting with Subsection 7.2.4.3, "Mode selection".

**COMMON screen (BASIC)**

Press soft key [COMMON]. The COMMON screen (BASIC) is displayed.

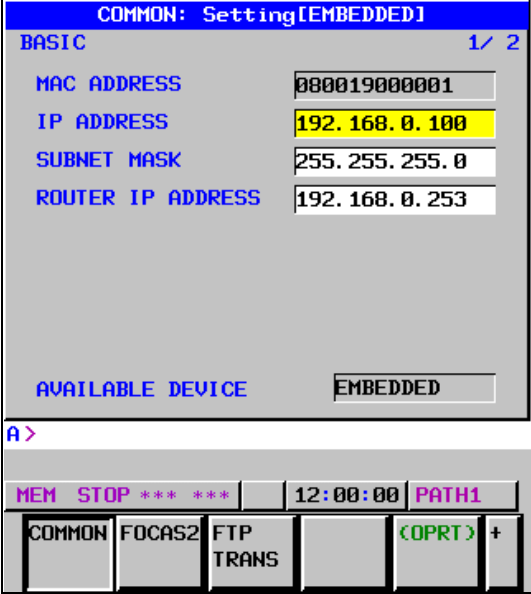

COMMON screen (BASIC)

**Setting items**

Item	Description
IP ADDRESS	Specify the IP address of the embedded Ethernet. (Example of specification format: "192.168.0.100")
SUBNET MASK	Specify a mask address for the IP addresses of the network. (Example of specification format: "255.255.255.0")
ROUTER IP ADDRESS	Specify the IP address of the router. Specify this item when the network contains a router. (Example of specification format: "192.168.0.253")

**Display items**

Item	Description
MAC ADDRESS	Embedded Ethernet MAC address
AVAILABLE DEVICE	Enabled device of the embedded Ethernet. Either the embedded Ethernet port or the PCMCIA Ethernet card is displayed.

**NOTE**

Set page 2 (DETAIL screen) of the COMMON screen when using the DNS/DHCP function. For details, see Subsection 7.2.3, "Setting Up the DNS/DHCP Function".

**COMMON screen (DETAIL)**

When using the DNS client function, press soft key [COMMON] then press page key  . The COMMON screen (DETAIL) is displayed. Set the DNS IP address setting items.



COMMON screen (DETAIL)

**Setting items**

Item	Description
DNS IP ADDRESS 1, 2	Up to two DNS IP addresses can be specified. The CNC searches for the DNS server using DNS IP addresses 1 and 2 in that order.

**FOCAS2 screen**

Press soft key [FOCAS2]. The FOCAS2 screen is displayed.

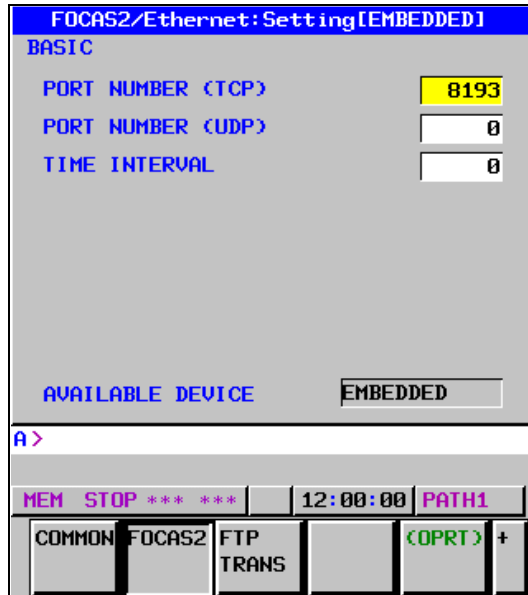

FOCAS2 screen

**Setting items**

Item	Description
PORT NUMBER (TCP)	Specify a port number to be used with the unsolicited messaging function (FOCAS2/Ethernet function). The valid input range is 5001 to 65535.

Item	Description
PORT NUMBER (UDP)	Set this item to 0 when it is used as the unsolicited messaging function (FOCAS2/Ethernet function).
TIME INTERVAL	Set this item to 0 when it is used as the unsolicited messaging function (FOCAS2/Ethernet function).

### 7.2.4.3 Mode selection

This subsection describes the selection of a mode for setting the unsolicited messaging function.

#### Unsolicited Message screen (BASIC)

Press soft key [UNSOLI MSG]. The Unsolicited Message screen (BASIC) is displayed.

Unsolicited Message screen 1 (BASIC)

#### Setting items

Item	Description
MODE	<p>Select a mode for setting the unsolicited messaging function. For the method of selection, see "<b>Operation</b>" described later.</p> <ul style="list-style-type: none"> <li>When "CNC MODE" is selected This mode enables setting on the CNC screen. In this case, setting on the personal computer is disabled. For details, see Subsection 7.2.4.4, "Setting on the CNC screen".</li> <li>When "PC MODE" is selected This mode enables setting on the personal computer. In this case, setting on the CNC screen is disabled. For details, see Subsection 7.2.4.5, "Setting on the personal computer".</li> </ul>

#### NOTE

- The mode is set to "PC MODE" at the time of initial use.
- The mode can be switched only in the "Not Ready" state. For the "Not Ready" state, see "**Display items**" provided later.
- If the mode is switched from "CNC MODE" to "PC MODE", all parameters set on the CNC screen are cleared.
- The mode can be switched on the available device side only.

### Operation

The mode can be switched as described below.

- 1 Press soft key [(OPRT)]. Soft key [MODE] is displayed.



- 2 Press soft key [MODE]. Soft keys [CNC MODE] and [PC MODE] are displayed.



### Display items

Item	Description
IP ADDRESS	Displays the IP address of the personal computer currently connected. (Example of display format: "192.168.0.1")
STATUS	Displays the current state. The following five states are available: <1> Not Ready State where data is not transmitted even when a request for data transmission is made from an NC program or ladder program <2> Ready State where data is transmitted when a request for data transmission is made from an NC program or ladder program <3> Sending... State present from the acceptance of a request for data transmission from an NC program or ladder program until data transmission is completed <4> Receiving... State present from completion of data transmission until response data is received <5> Completed State present from reception of response data until response data processing is completed  [Supplement] • Data transmission Means unsolicited message transmission (CNC→PC). • Response data Means a response to an unsolicited message (PC→CNC).
AVAILABLE DEVICE	Device where embedded Ethernet is currently enabled. The embedded Ethernet port or PCMCIA Ethernet card is displayed.

#### NOTE

- 1 To switch the state from "Not Ready" to "Ready", the FOCAS2 function `cnc_unsolicstart` needs to be executed on the personal computer.
- 2 To switch the state from other than "Not Ready" to "Not Ready", the FOCAS2 function `cnc_unsolicstop` needs to be executed on the personal computer.
- 3 For the timing charts of the states, see Subsection 7.2.4.6, "Execution methods".



## 7.2.4.4 Setting on the CNC screen

This subsection describes the method of setting on the Unsolicited Message screen.

### NOTE

- 1 To enable the settings on the CNC screen and perform unsolicited messaging, the procedure below needs to be used.
  - (1) Set all setting items on the Unsolicited Message screen (CONNECT).
  - (2) Press soft key [(OPRT)] then press soft key [APPLY].
  - (3) Start unsolicited messaging (execute the FOCAS2 function cnc\_unsolicstart) on the personal computer.
- 2 Setting of the setting items on the Unsolicited Message screen (CONNECT) and execution of the soft keys ([(OPRT)] then [APPLY]) are possible only in the "Not Ready" state. For the "Not Ready" state, see "Display items" in Subsection 7.2.4.3, "Mode selection".
- 3 On the setting screen on the unavailable device side, the setting items can be set. However, execution of the soft keys ([(OPRT)] then [APPLY]) is possible on the available device side only.

### Unsolicited Message screen (CONNECT)

Press soft key [UNSOLI MSG] then open page 2 and page 3 with page keys  . The Unsolicited Message screen (CONNECT) is displayed.

Unsolicited Message screen 2 (CONNECT)

NO.	TYPE	PMC ADDRESS	MACRO NO.	SIZE
1	1	1:R0100		100
2	3	1:100		10
3	4	1:0		1

Unsolicited Message screen 3 (CONNECT)

### Setting items

Item	Description
HOST NAME (IP ADDRESS)	When the DNS client function is disabled, specify the IP address of the communication destination personal computer. (Example of specification format: "192.168.0.1") When the DNS client function is enabled, specify the host name of the communication destination personal computer. (Up to 63 characters can be specified.) (Example of specification format: "UNSOLI-SRV.FACTORY")



Item	Description	
PORT NUMBER	Specify the TCP port number and UDP port number of the communication destination personal computer. Usually, specify "8196". The valid input range is 5001 to 65535.	
RETRY COUNT	Specify the number of retries to be made when there is no response to data transmitted by the communication function. The valid input range is 0 to 32767.	
TIMEOUT	Specify a time-out period (in sec) from the transmission of data by the communication function until a response is made to the transmitted data. The valid input range is 1 to 32767.	
ALIVE TIME	Specify the time interval (in sec) of the alive signal to be transmitted while the communication function is operating normally. Specify a value not greater than the value of TIMEOUT. The valid input range is 1 to 32767.	
CONTROL PARAMETER TYPE	Specify a type of control parameter. When this parameter is set to 0, the control parameter is invalid. <ul style="list-style-type: none"> <li>• When set to 1: PMC address (response notification method)</li> <li>• When set to 2: PMC address (simplified method)</li> <li>• When set to 3: Custom macro variable (simplified method)</li> <li>• When set to 4: Volatile RTM variable (simplified method)</li> </ul> <b>(Note)</b> The RTM variable is a real-time custom macro variable.	
CONTROL PARAMETER	Specify a control parameter for executing data transmission.	
	When CONTROL PARAMETER TYPE is set to 1	
	Specify a PMC address for control. A PMC address in the R area or E area may be specified. Two bytes starting at a specified address are allocated in the area.	
	When CONTROL PARAMETER TYPE is set to 2	
	Specify a PMC address for control. A PMC address in the R area or E area may be specified. Only a specified address (one byte) is allocated in the area.	
CONTROL PARAMETER	When CONTROL PARAMETER TYPE is set to 3	
	Specify a custom macro variable number for control. Only a volatile common variable may be specified as a custom macro variable. Only the variable with a specified variable number is allocated in the area.	
CONTROL PARAMETER	When CONTROL PARAMETER TYPE is set to 4	
	Specify a RTM variable number for control. Only a volatile RTM variable may be specified as a RTM variable. Only the variable with a specified variable number is allocated in the area.	
TRANSMISSION NUMBER	Specify the number of data items to be transmitted. The valid input range is 1 to 3.	
TRANSMISSION PARAMETER (NO.1 to 3)	Specify each parameter for transmission data.	
TYPE	Specify a transmission data type. When this parameter is set to 0, the transmission parameter is invalid. <ul style="list-style-type: none"> <li>• When set to 1 or 2: PMC address</li> <li>• When set to 3: Custom macro variable</li> <li>• When set to 4: Volatile RTM variable</li> <li>• When set to 5: Nonvolatile RTM variable</li> </ul>	
	PMC ADDRESS or MACRO NO.	Specify the start of a transmission data area
		When TYPE is set to 1 or 2
		Specify a PMC address for transmission.
		When TYPE is set to 3
Specify a custom macro variable number for transmission.		
PMC ADDRESS or MACRO NO.	When TYPE is set to 4 or 5	
	Specify a RTM variable number for transmission.	

Item	Description
SIZE or NUMBER	Specify the size of a transmission data area or the number of variables. The maximum specifiable number of bytes is as follows: <ul style="list-style-type: none"> <li>• When TRANSMISSION NUMBER is set to 1: 2890 bytes</li> <li>• When TRANSMISSION NUMBER is set to 2: 2874 bytes in total</li> <li>• When TRANSMISSION NUMBER is set to 3: 2858 bytes in total</li> </ul> When using macro variables (custom macro variables or RTM variables), use a conversion rate of one variable for eight bytes.
	When TYPE is set to 1 or 2 Specify a PMC area size (bytes) for transmission.
	When TYPE is set to 3 Specify the number of custom macro variables for transmission. When a macro variable number of 1000 or greater (system variable) is used, this parameter can be set to 1 only.
	When TYPE is set to 4 or 5 Specify the number of RTM variables for transmission.

 **CAUTION**

- 1 When setting a PMC address for control or a PMC address for transmission, observe the following:
  - (1) When a multi-path PMC is used, use the following input format:  
 <path-number>:<PMC-address>  
 When specifying the PMC address R0500 of the second PMC path, for example, input "2:R500". When only the PMC address (R500) is input, the specification of the first path (1:R0500) is assumed for processing.  
 When the key for ":" is unavailable, use the key for "/" or "EOB" instead.
  - (2) Ensure that a PMC address area for control never overlaps PMC areas used by other functions (FL-net, PROFIBUS-DP, DeviceNet, and CC-Link).
- 2 When setting a macro variable for control or a macro variable for transmission, observe the following:
  - (1) When a multi-path CNC is used, use the following input format:  
 <path-number>:<variable-number>  
 When specifying variable number #100 of the second CNC path, for example, input "2:100". When only the variable number (100) is input, the specification of the first path (1:100) is assumed for processing.  
 When the key for ":" is unavailable, use the key for "/" or "EOB" instead.
  - (2) Ensure that a macro variable for control never be doubly specified as a variable to be used for a purpose other than the unsolicited messaging function.

**NOTE**

- 1 Two methods are available for PMC address specification in CONTROL PARAMETER TYPE: response notification method and simplified method. For details of the methods, see Subsection 7.2.4.6, "Execution methods".
- 2 The valid setting range of PMC addresses depends on the usable PMC memory type. For details, refer to "PMC Programming Manual (B-64513EN)".
- 3 The valid setting ranges of custom macro variable numbers and RTM variable numbers depend on the selected options. For details, refer to "Operator's Manual (Common to Lathe System/Machining Center System) (B-64484EN)".

**NOTE**

- 4 Ensure that the setting of TRANSMISSION NUMBER matches the settings of TRANSMISSION PARAMETER (NO. 1 to NO. 3). If TRANSMISSION NUMBER is set to 3, and an invalid value is specified in any of TRANSMISSION PARAMETER NO. 1 to NO. 3, for example, execution of soft key [APPLY] results in an error.

**Operation**

The settings of all setting items on the Unsolicited Message screen (CONNECT) can be made effective as follows:

- 1 Press soft key [(OPRT)]. Soft key [APPLY] is displayed.



- 2 Press soft key [APPLY].

**7.2.4.5 Setting on the personal computer**

For setting on the personal computer, create and set an application by using the following FOCAS2 functions:

- cnc\_wrunsolicprm2 Parameter setting 2 for unsolicited messaging
- cnc\_unsolicstart Start of unsolicited messaging

For details, refer to Chapter 5, "Unsolicited Messaging Function", in the "Data Window Library Specifications" supplied with the FOCAS1/2 library.

**NOTE**

- 1 To start unsolicited messaging, the FOCAS2 function cnc\_wrunsolicprm2 needs to be executed first then the FOCAS2 function cnc\_unsolicstart needs to be executed.
- 2 The FOCAS2 function cnc\_wrunsolicprm2 can be executed only in the "Not Ready" state. For details of the state, see "**Display items**" in Subsection 7.2.4.3, "Mode selection".
- 3 When the FOCAS2 function cnc\_wrunsolicprm2 is executed, the Unsolicited Message screen (CONNECT) displays the settings made on the personal computer.

**7.2.4.6 Execution methods**

How to execute the unsolicited messaging function is described below.

To execute the unsolicited messaging function, three methods are available:

- Using a PMC address for control based on the response notification method in a ladder program
- Using a PMC address for control based on the simplified method in a ladder program
- Using a macro variable for control based on the simplified method in an NC program

**NOTE**

- 1 When a ladder program is used, the response notification method and the simplified method are available. A major difference is that the response notification method sends RES\_CODE to the ladder program in response to data transmission but the simplified method does not send a response. To utilize a ladder program based on logic used with the Series 16i, for example, use the response notification method. When RES\_CODE is unnecessary or a new ladder program is created, the simplified method can be used.
- 2 RES\_CODE is recorded on the Ethernet log screen when a value other than 0x00 and 0x01 is detected.
- 3 For details of RES\_CODE, refer to Chapter 5, "Unsolicited Messaging Function", in the "Data Window Library Specifications" supplied with the FOCAS1/2 library.

**When a PMC address for control is used (response notification method)**

A description of using a PMC address for control in a ladder program according to the response notification method is provided below.

**NOTE**

A combination of a PMC address for control and a macro variable for transmission is also usable. In this case, note that the read timing of the value of a macro variable to be transmitted cannot be identified when viewed from the ladder program. In the description below, a PMC address is used for both of control and transmission.

**Explanation of PMC address signals for control**

A detailed description of PMC address signals for control used to execute the unsolicited messaging function is provided below. A PMC address area for control consists of 2 bytes. The description below assumes that Rxxxx (with no PMC path number specified) is used as a PMC address for control.

No.	#7	#6	#5	#4	#3	#2	#1	#0
Rxxxx	REQ							

**REQ** <Rxxxx.7>

- [Name] Message transmission request signal
- [Classification] Input signal
- [Function] Requests transmission of an unsolicited message.
- [Operation] After preparing a transmission message at a PMC address for transmission, the ladder program sets this signal to 1. The message is then transmitted to the personal computer.

No.	#7	#6	#5	#4	#3	#2	#1	#0
Rxxxx+1	RES	COM	RES_CODE					

**RES** <Rxxxx+1.7>

- [Name] Message response reception signal
- [Classification] Output signal
- [Function] Posts the reception of a response to an unsolicited message.

[Output condition] Upon reception of a message by the personal computer, a response to the message is transmitted to the CNC (communication function). When the CNC (communication function) receives the response, this signal is set to 1. When this signal is set to 1, the ladder program reads RES\_CODE then clears REQ to 0. Next, the CNC (communication function) clears RES\_CODE to 0 then sets this signal to 0.

**COM** <Rxxxx+1.6>

[Name] Message transmission start signal

[Classification] Output signal

[Function] Posts the start of transmission of an unsolicited message.

[Output condition] When transmission of a message to the personal computer is started, this signal is set to 1. Upon completion of message transmission, this signal is set to 0.

**RES\_CODE** <Rxxxx+1.0> to <Rxxxx+1.5>

[Name] Message response reception result signal

[Classification] Output signal

[Function] Posts the reception result of a response to an unsolicited message.

[Output condition] The reception result of a response to a message is set. After reading this signal, the ladder program clears REQ to 0. The CNC (communication function) then clears this signal to 0.

**NOTE**

For details of RES\_CODE, refer to Chapter 5, "Unsolicited Messaging Function", in the "Data Window Library Specifications" supplied with the FOCAS1/2 library.

**Timing chart of PMC address signals for control**

The timing chart of PMC address signals for control based on the response notification method is described below.

In the example below, an unsolicited message is transmitted once after reception of the FOCAS2 function cnc\_unsolicstart then the FOCAS2 function cnc\_unsolicstop is received.

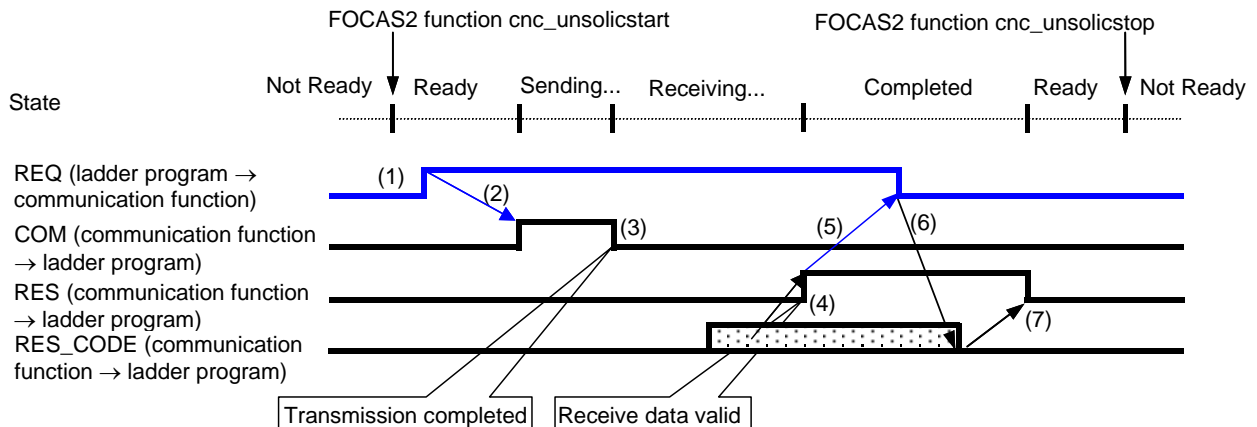

- (1) After checking that RES is set to 0, the ladder program prepares a message then sets REQ to 1.
- (2) Because of REQ set to 1, the communication function sets COM to 1 then transmits the message.
- (3) Upon completion of message transmission, the communication function sets COM to 0.
- (4) Upon reception of a response to the message, the communication function sets RES\_CODE then sets RES to 1.
- (5) Because of RES set to 1, the ladder program reads RES\_CODE then sets REQ to 0.
- (6) Because of REQ set to 0, the communication function clears RES\_CODE to 0.
- (7) The communication function sets RES to 0.

**NOTE**  
 For details of the states, see "Display items" in Subsection 7.2.4.3, "Mode selection".

**When a PMC address for control is used (simplified method)**

A description of using a PMC address for control in a ladder program according to the simplified method is provided below.

**NOTE**  
 A combination of a PMC address for control and a macro variable for transmission is also usable. In this case, note that the read timing of the value of a macro variable to be transmitted cannot be identified when viewed from the ladder program.  
 In the description below, a PMC address is used for both of control and transmission.

**Explanation of PMC address signals for control**

A detailed description of PMC address signals for control used to execute the unsolicited messaging function is provided below. A PMC address area for control consists of 1 byte. The description below assumes that Rxxxx (with no PMC path number specified) is used as a PMC address for control.

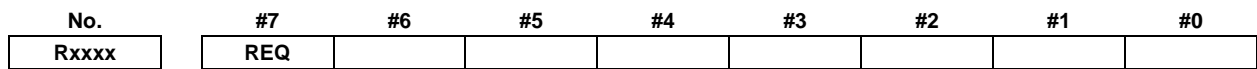

- REQ** <Rxxxx#7>  
 [Name] Message transmission request signal  
 [Classification] Input/Output signal  
 [Function] Requests transmission of an unsolicited message.  
 [Operation] After preparing a transmission message at a PMC address for transmission, the ladder program sets this signal to 1. The message is then transmitted to the personal computer. Upon reception of a response to the message, the CNC (communication function) clears this signal to 0.

**Timing chart of PMC address signals for control**

The timing chart of PMC address signals for control based on the simplified method is described below. In the example below, an unsolicited message is transmitted once after reception of the FOCAS2 function cnc\_unsolicstart then the FOCAS2 function cnc\_unsolicstop is received.

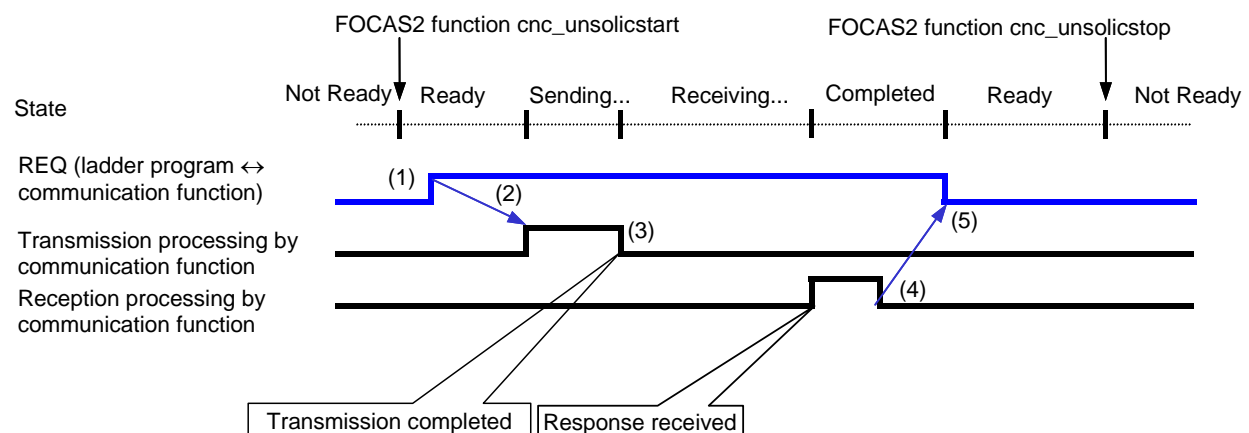

- (1) After checking that REQ is set to 0, the ladder program prepares a message then sets REQ to 1.
- (2) Because of REQ set to 1, the communication function transmits the message.
- (3) The communication function completes message transmission processing.
- (4) Upon reception of a response to the message, the communication function completes reception processing.
- (5) Because of reception processing completed, the communication function sets REQ to 0.

**NOTE**

For details of the states, see "**Display items**" in Subsection 7.2.4.3, "Mode selection".

**When a macro variable for control is used (simplified method)**

A description of using a macro variable for control in an NC program according to the simplified method is provided below.

Macro variables for control are classified as custom macros and RTM macros, but the same execution method is applicable.

**NOTE**

A combination of a macro variable for control and a PMC address for transmission is also usable. In this case, note that the read timing of the value of PMC data to be transmitted cannot be identified when viewed from the NC program.

In the description below, a macro variable is used for both of control and transmission.

**Explanation of a macro variable for control**

A detailed description of a macro variable for control used to execute the unsolicited messaging function is provided below. One macro variable for control is used.

The description below assumes that #xxxx (with no CNC path number specified) is used as a macro variable number for control.

**REQ** <#xxxx>

[Name] Message transmission request signal

[Classification] Input/Output signal

[Function] Requests transmission of an unsolicited message.

[Operation] After preparing a transmission message in a macro variable for transmission, the NC program sets this signal to 1. The message is then transmitted to the personal computer. Upon reception of a response to the message, the CNC (communication function) clears this signal to 0.

**NOTE**

A REQ input/output value is a real number. So, "0" means "0.0", and "1" means "1.0".

**Timing chart of a macro variable for control**

The timing chart of a macro variable for control based on the simplified method is described below.

In the example below, an unsolicited message is transmitted once after reception of the FOCAS2 function `cnc_unsolicstart` then the FOCAS2 function `cnc_unsolicstop` is received.

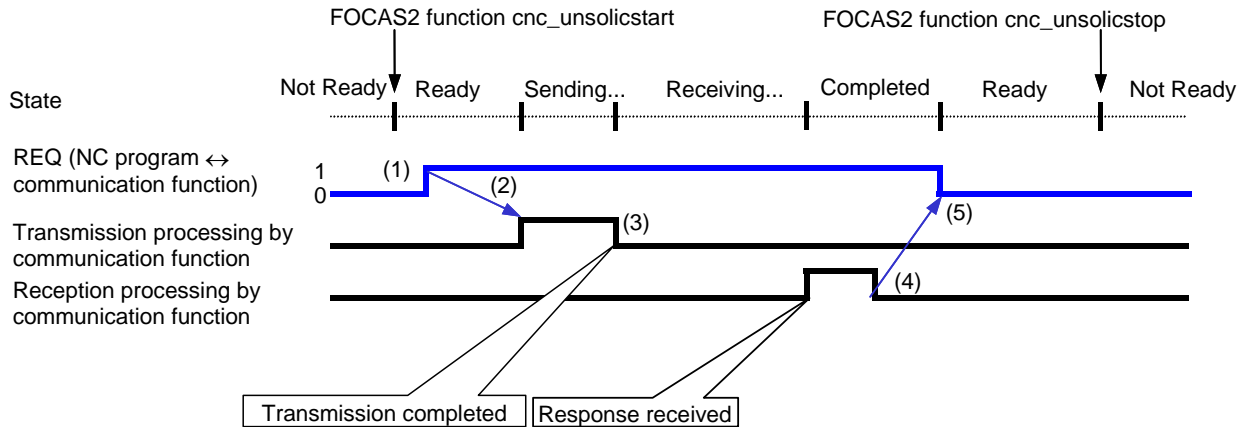

- (1) After checking that REQ is set to 0, the NC program prepares a message then sets REQ to 1.
- (2) Because of REQ set to 1, the communication function transmits the message.
- (3) The communication function completes message transmission processing.
- (4) Upon reception of a response to the message, the communication function completes reception processing.
- (5) Because of reception processing completed, the communication function sets REQ to 0.

**NOTE**  
 For details of the states, see "Display items" in Subsection 7.2.4.3, "Mode selection".

**Example of using a macro variable for control**

An example of using a macro variable for control is provided below.

- Example  
 [Description]  
 An NC program on CNC path number 1 posts NC command start date and time information as an unsolicited message to the personal computer.  
 [Setting]  
 As a macro variable for control, volatile RTM variable number #0 (REQ) is used. On the other hand, macro variables for transmission are used for date and time information managed inside the CNC (system variable numbers #3011 and #3012).

Setting item	Set value
CONTROL PARAMETER TYPE	4
CONTROL PARAMETER	1:0
TRANSMISSION NUMBER	2
TRANSMISSION PARAMETER (NO.1)	
TYPE	3
MACRO NO.	1:3011
NUMBER	1
TRANSMISSION PARAMETER (NO.2)	
TYPE	3
MACRO NO.	1:3012
NUMBER	1

[Example of NC program]

A RTM variable is executed in synchronism with the immediately following NC command according to the RTM variable specification. At this time, the operation timing of the immediately following NC command is not affected.



So, the NC program indicated below posts NC command 2 start date and time information as an unsolicited message to the personal computer.

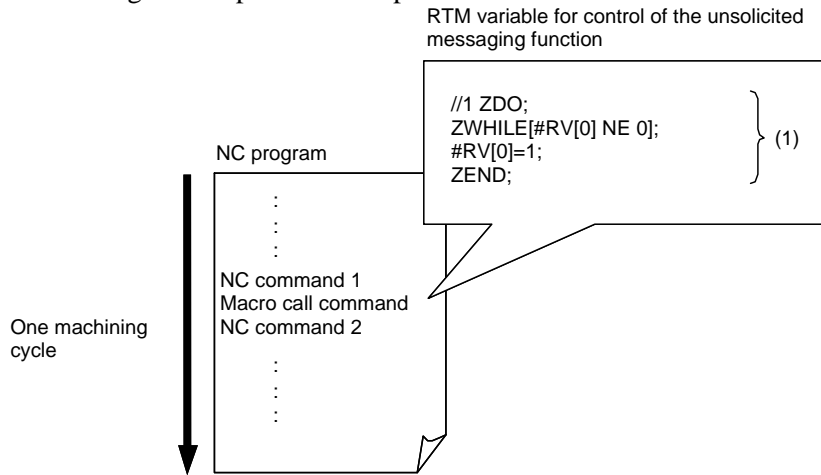

(Tip) (1) in the example above corresponds to the number in the timing chart provided earlier.

**NOTE**

- 1 Note that if a custom macro is used as a macro for control, the operation timing of an NC command is affected. If the RTM variable in the example above is replaced with a custom macro, for example, NC command 2 becomes unexecutable unless the macro variable for control is changed.
- 2 For details of custom macros and RTM variables, refer to "Operator's Manual (Common to Lathe System/Machining Center System) (B-64484EN)".

### 7.2.4.7 Related NC parameters

#### For embedded Ethernet port

	#7	#6	#5	#4	#3	#2	#1	#0
14880				UNM				

[Input type] Parameter input  
 [Data type] Bit

**#4 UNM** With the embedded Ethernet port, the unsolicited messaging function is:  
 0: Not used  
 1: Used

**NOTE**

- 1 Re-setting this parameter requires turning the power off and on again or restarting the embedded Ethernet interface.
- 2 To use the CNC Unsolicited Messaging function with a built-in port, the Enhanced Embedded Ethernet function (-R952) is required.

	#7	#6	#5	#4	#3	#2	#1	#0
14882				UNS				

[Input type] Parameter input  
 [Data type] Bit

#4 UNS When the embedded Ethernet port is used and termination of the unsolicited messaging function is specified from other than the connected unsolicited message server, the function:

- 0: Rejects termination.
- 1: Accepts termination.

**NOTE**  
 To use the CNC Unsolicited Messaging function with a built-in port, the Enhanced Embedded Ethernet function (-R952) is required.

## 7.2.5 Backing Up and Restoring Communication Parameters

This subsection describes operations for backing up the communication parameters for the embedded Ethernet in a memory card or USB memory and restoring them from a memory card. Which memory, memory card or USB memory, is to be used in backup/restoration is determined using NC parameter No. 20. For descriptions of the USB memory specifications and restrictions, refer to Section 8.6, "USB Functions", in Part III, "OPERATION", in "Operator's Manual (Common to Lathe System/Machining Center System) (B-64484EN)".

- 1 Press the function key .
- 2 Soft keys [EMBED PORT] and [PCMCIA LAN] appear. (When there is no soft keys, press the continue key.)
- 3 To display the Ethernet Setting screen for the embedded Ethernet port or the PCMCIA Ethernet card, press soft key [EMBED PORT] or [PCMCIA LAN], respectively.
- 4 Press soft keys [COMMON], [(OPRT)], and [+] in this order. Soft keys for backing up and restoring communication parameters, [BACKUP], [RESTORE], [ALL BACKUP], and [ALL RESTORE], appear as shown below.
- 5 Press soft key [BACKUP], [RESTORE], [ALL BACKUP], or [ALL RESTORE]. Soft keys [EXECUTE] and [CANCEL] appear.
- 6 Enter the name of a file to be backed up or restored in the key-in buffer and press soft key [EXECUTE]. The relevant operation is executed.  
 During execution, "EXECUTING" blinks.

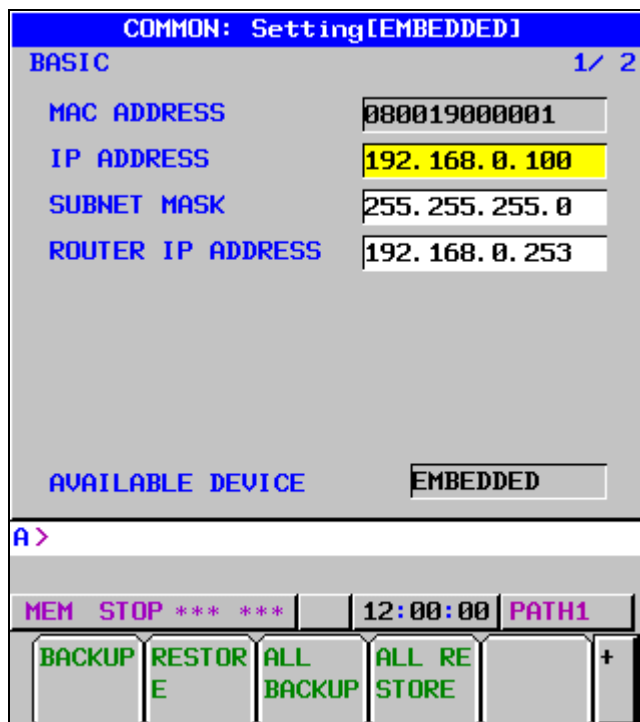

**BACKUP**

Saves the communication parameters for the embedded Ethernet that are stored in the SRAM of the CNC in such as memory card.

If a file name is specified in the key-in buffer, it is used in saving parameters to a memory unit such as a memory card. If no file name is specified, file name "EMBETHER.MEM" is used.

**RESTORE**

Reads the communication parameters for the embedded Ethernet that are stored in such as memory card and saves them in the SRAM of the CNC.

If a file name is specified in the key-in buffer, it is used in reading parameters from a memory unit such as a memory card. If no file name is specified, a file having file name "EMBETHER.MEM" is read.

**ALL BACKUP**

Saves all valid communication parameters for the embedded Ethernet, fast Ethernet/fast data server, PROFIBUS-DP master/slave, DeviceNet master/slave, FL-net, and CC-Link remote device that are stored in the SRAM of the CNC in such as memory card.

If a file name is specified in the key-in buffer, it is used in saving parameters to a memory unit such as a memory card. If no file name is specified, file name "NETWORK.MEM" is used.

**ALL RESTORE**

Reads all valid communication parameters for the embedded Ethernet, fast Ethernet/fast data server, PROFIBUS-DP master/slave, DeviceNet master/slave, FL-net, and CC-Link remote device that are stored in such as memory card and saves them in the SRAM of the CNC.

If the communication function relevant to any valid parameter is disabled on the CNC, however, the communication parameter is not saved in the SRAM.

If a file name is specified in the key-in buffer, it is used in reading parameters from a memory unit such as a memory card. If no file name is specified, a file having file name "NETWORK.MEM" is read.

**⚠ CAUTION**

When you are gaining access to an external input/output device, such as a memory card and USB memory, do not turn off the power to the CNC or disconnect the external input/output device. It is likely that doing so may damage the external input/output device.

**NOTE**

- 1 Communication parameters can be backed up and restored only in the MDI mode, EDIT mode, or the emergency stop state.
- 2 Restoring communication parameters causes an alarm requiring the power to be turned off to be issued.

**Related NC parameters**

0020

I/O CHANNEL : Input/output device selection, or interface number for a foreground input device

[Input type] Setting input

[Data type] Byte

[Valid data range] 4 : Select the memory card as the input/output device.

17 : Select the USB memory as the input/output device.

Any input/output device other than those listed above cannot be used to back up or restore communication parameters.

## 7.3 SWITCHING BETWEEN THE EMBEDDED ETHERNET DEVICES

There are two types of embedded Ethernet devices: the embedded Ethernet port and PCMCIA Ethernet card.

Screen operation is required to switch between these two types of devices.

### Procedure

- 1 Press the function key .
- 2 Soft keys [EMBED PORT] and [PCMCIA LAN] appear.  
(When there is no soft keys, press the continue key.)
- 3 Press soft key [EMBED PORT] or [PCMCIA LAN], press soft key [COMMON], and then press [(OPRT)] to display soft key [EMB/PCMCIA].
- 4 Pressing soft key [EMB/PCMCIA] switches between enabled devices.

### NOTE

- 1 Information on a switched device is stored in nonvolatile memory.  
On the next power-on, the device last selected can be used as is.
- 2 When using the unsolicited messaging function, note the following:
  - Processing is forcibly started from the "Not Ready" state, regardless of the unsolicited message transfer state.
  - When the parameter for control is set to use the response notification method, RES and RES\_CODE (0x01) are posted to the ladder program.
  - When the parameter for control is set to use the simplified method, REQ is cleared.

## 7.4 EMBEDDED ETHERNET OPERATIONS

### 7.4.1 FTP File Transfer Function

The operation of the FTP file transfer function is described below.

#### Host file list display

A list of the files held on the host computer is displayed.

### Procedure

- 1 Press the function key .
- 2 Press soft key [FOLDER]. The program folder screen appears. (If the soft key does not appear, press the continuous menu key.)

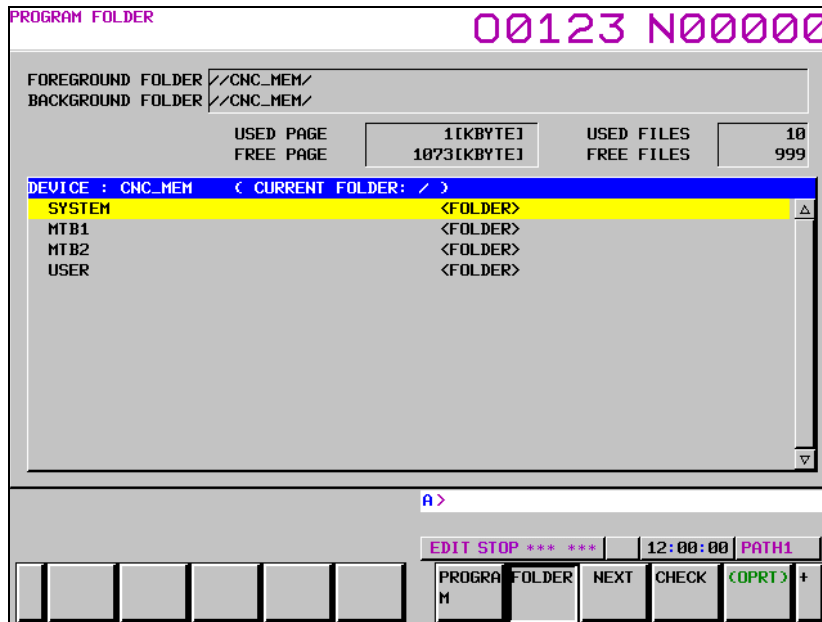

- 3 Press soft keys [(OPRT)] and [DEVICE CHANGE] in that order. The soft keys for selectable devices appear.



- 4 Press soft key [EMB ETHER]. The program directory screen is changed to the contents of the hard disk on the host computer (embedded Ethernet host file list screen). On this screen, you can operate files.

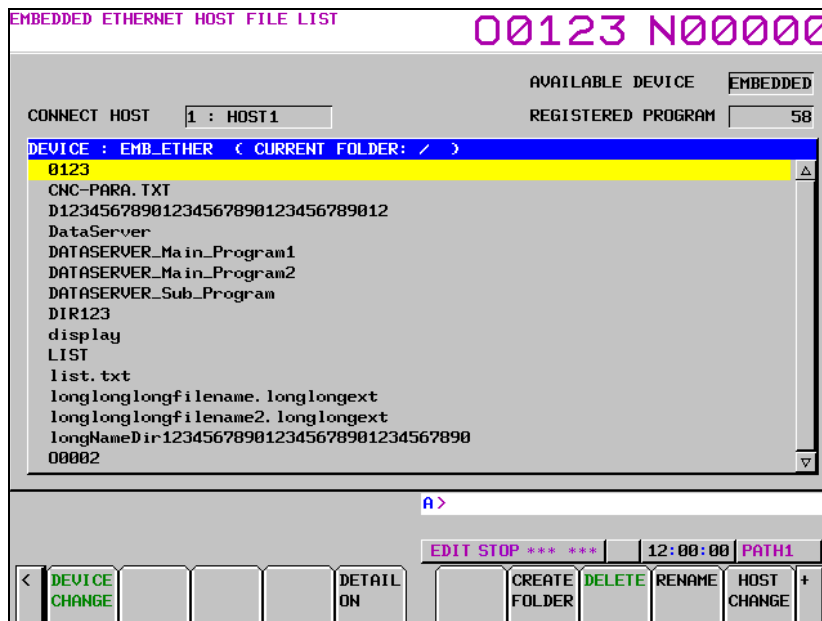

Embedded Ethernet host file list screen

**NOTE**

When using the FTP file transfer function, check that the valid device is the embedded Ethernet port.  
 The two conditions below determine a connection destination on the host file list screen:

- (1) Check that the valid device is the embedded Ethernet port. Make a selection in "DEVICE SELECTION" on the Ethernet setting screen.
- (2) A host computer can be selected from connection destinations 1, 2, and 3. Make a selection according to the [HOST] soft key described later.

- 5 When a list of files is larger than one page, the screen display can be switched using the page keys

**Display item****AVAILABLE DEVICE**

The currently selected device is displayed.  
 Check that the embedded Ethernet port is selected currently.

**CONNECT HOST**

Number of the currently connected host of the host computer

**REGISTERED PROGRAM**

The number of files in the current folder.

**DEVICE**

Current device. When the embedded Ethernet host file list is selected, "EMB\_ETHER" is displayed.

**CURRENT FOLDER**

Current work folder in the host computer

**FILE LIST**

Information of the files and folders in the host computer

**Operation list****DEVICE CHANGE**

Enables a device to be selected from the program folder screen. To select the embedded Ethernet host file list, press soft key [EMB ETHER].

**DETAIL ON, DETAIL OFF**

Switches between the outline and detailed file lists.

**CREATE FOLDER**

Creates a new subfolder in the current work folder.

**DELETE**

Deletes a file or folder.

**RENAME**

Renames a file or folder.

**HOST CHANGE**

Changes the connected host computer.

**SEARCH**

Searches the current folder for a file.

**REFRESH**

Updates the information displayed on the embedded Ethernet host file list screen.

**7.4.1.1 Displaying and operating the file list****REFRESH, DETAIL ON, DETAIL OFF**

Update the file list data or change the file list type.



- 1 Press soft key [REFRESH] to update the file list data.
- 2 Press soft key [DETAIL OFF] to display only file names.
- 3 Press soft key [DETAIL ON] to display file attributes, sizes, dates, and file names.

**NOTE**

The items displayed in the detailed list depend on the FTP server setting on the host computer.

**Moving a folder**

Move a folder.

- 1 Select a folder you want to move using cursor keys  and .
- 2 Press MDI key .



**CREATE FOLDER**

Create a new folder.

- 1 Move to a folder in which you want to create a new folder.
- 2 Enter a folder name.
- 3 Press soft key [CREATE FOLDER].



**DELETE**

Delete a file or folder.

- 1 Select a file or folder you want to delete using cursor keys  and .
- 2 Press soft key [DELETE].
  - To execute the deletion, press soft key [EXEC].
  - To cancel the deletion, soft key [CANCEL].

**DELETE (multiple files)**

Delete multiple files at a time.

- 1 Press soft key [SELECT START].
- 2 Select a file or folder you want to delete using cursor keys  and .
- 3 Press soft key [SELECT].  
The selected file is highlighted.  
Repeat steps 2 and 3 for each file you want to delete.



- 4 Press soft key [DELETE].
  - To execute the deletion, press soft key [EXEC].
  - To cancel the deletion, soft key [CANCEL].

**NOTE**

Up to 10 files can be selected at a time.

**RENAME**

Rename a file or folder.

- 1 Select a file or folder you want to rename using cursor keys  and .
- 2 Enter a new file or folder name.
- 3 Press soft key [RENAME].

**SEARCH**

Search the current work folder for a file.

- 1 Enter a file name.
- 2 Press soft key [SEARCH].

**HOST CHANGE**

Change the connected host computer.

- 1 Press soft key [HOST CHANGE].  
The connected host number changes from 1 to 2 to 3, then back to 1.

## 7.5 RESTART OF THE EMBEDDED ETHERNET

Communication using the embedded Ethernet can be restarted.

**Procedure**

- 1 Press the function key .
- 2 Soft keys [EMBED PORT] and [PCMCIA LAN] appear.  
(When there is no soft keys, press the continue key.)
- 3 Press soft key [EMBED PORT] or [PCMCIA LAN], press soft key [COMMON], and then press [(OPRT)] to display soft key [RSTART].
- 4 Pressing soft key [RSTART] resets embedded Ethernet communication and then restarts it.

**NOTE**

- 1 Pressing soft key [RSTART] forcibly interrupts communication even when it is in progress.
- 2 This function makes a restart by software. An actual restart may be impossible under some conditions.
- 3 When using the unsolicited messaging function, note the following:
  - Processing is forcibly started from the "Not Ready" state, regardless of the unsolicited message transfer state.
  - When the parameter for control is set to use the response notification method, RES and RES\_CODE (0x01) are posted to the ladder program.
  - When the parameter for control is set to use the simplified method, REQ is cleared.



# 7.6 MAINTENANCE SCREEN FOR EMBEDDED ETHERNET FUNCTION



With the embedded Ethernet function, a dedicated maintenance screen is available. The maintenance screen enables operations to be checked when the embedded Ethernet function operates abnormally.

## Displaying and operating the PING screen

### Procedure

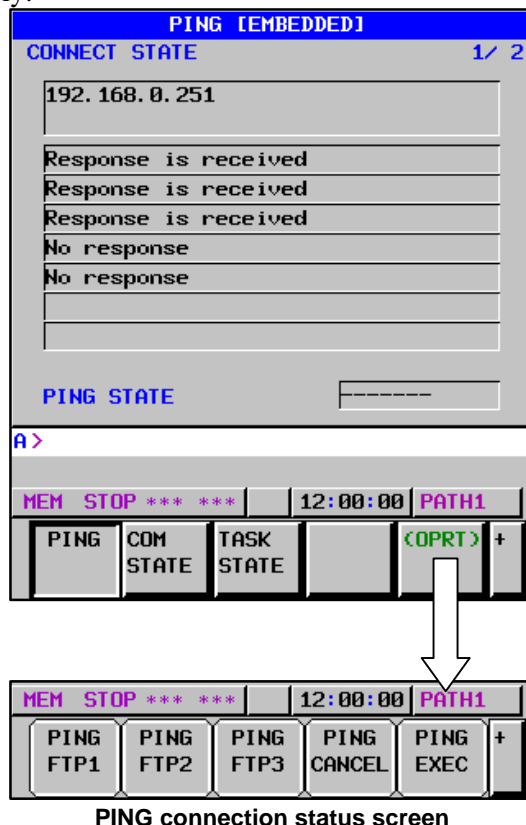
- 1 Press the function key .
- 2 Soft keys [EMBED PORT] and [PCMCIA LAN] appear.  
(When there is no soft keys, press the continue key.)
- 3 By pressing the [EMBED PORT] soft key, the Ethernet Setting screen for the embedded Ethernet is displayed.  
By pressing the [PCMCIA LAN] soft key, the Ethernet Setting screen for the PCMCIA Ethernet card can be set.
- 4 Press soft key [PING] and then press [(OPRT)].
- 5 To send the PING command to connection destination 1 for FTP file transfer, press soft key [PING FTP1] Similarly, to send the PING command to connection destination 2 or 3, press [PING FTP2] or [PING FTP3], respectively.



- 6 To send the PING command to the desired destination, enter the address of the destination on the PING setting screen. (Page keys   are used for switching.)

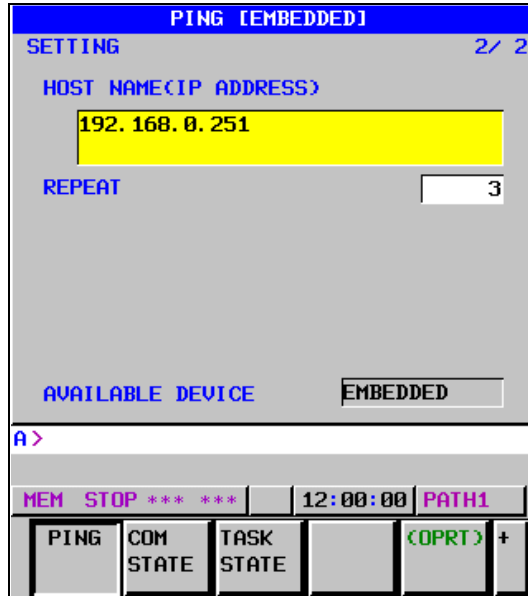



PING connection status screen

- 7 After entering the address and the repeat count, press the soft key [PING EXEC]. The specified number of PING commands are sent to the specified destination.
- 8 To cancel the PING command currently being sent, press soft key [PING CANCEL].

**Displaying Communication status screen**

**Procedure**

- 1 Press the function key .
- 2 Soft keys [EMBED PORT] and [PCMCIA LAN] appear.  
(When there is no soft keys, press the continue key.)
- 3 By pressing the [EMBED PORT] soft key, the Ethernet Setting screen for the embedded Ethernet is displayed.  
By pressing the [PCMCIA LAN] soft key, the Ethernet Setting screen for the PCMCIA Ethernet card can be set.
- 4 To display the communication status of the embedded Ethernet, press soft key [COM STATE].  
Page keys   can be used to switch between the sending state and the receiving state.

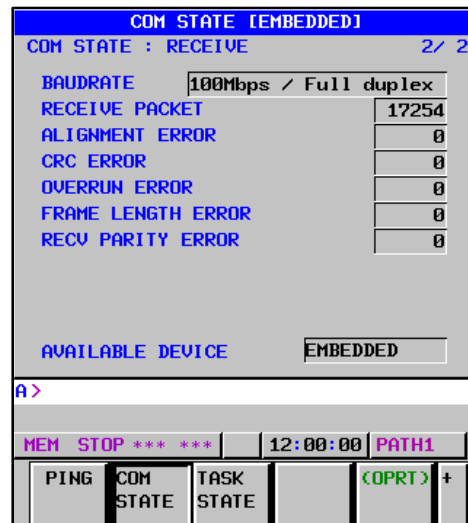
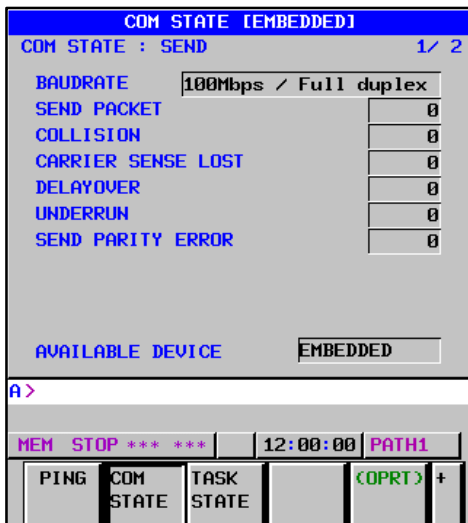

Communication status screen

**Display items**

Item	Description
BAUDRATE	Displays the baud rate and transmission method. Transmission rate: 100Mbps or 10Mbps Transmission method: Full duplex or half duplex ----- : Not connected to HUB
SEND PACKET	Displays the number of transmitted packets.
COLLISION CARRIER SENSE LOST DELAYOVER UNDERRUN SEND PARITY ERROR	Displays the number of errors detected during transmission of packets.
RECEIVE PACKET	Displays the number of packets received.
ALIGNMENT ERROR CRC ERROR OVERRUN ERROR FRAME LENGTH ERROR RCV PARITY ERROR	Displays the number of errors detected during reception of packets.
AVAILABLE DEVICE	Currently available device of embedded Ethernet Displays either the embedded Ethernet port or the PCMCIA Ethernet card.

**TASK STATE screen**

**Procedure**

- 1 Press the function key .
- 2 Soft keys [EMBED PORT] and [PCMCIA LAN] appear.  
(When there is no soft keys, press the continue key.)
- 3 To display the Ethernet Setting screen for the embedded Ethernet port or the PCMCIA Ethernet card, press soft key [EMBED PORT] or [PCMCIA LAN], respectively.
- 4 Pressing soft key [TASK STATUS] causes the task status of the embedded Ethernet function to be displayed.

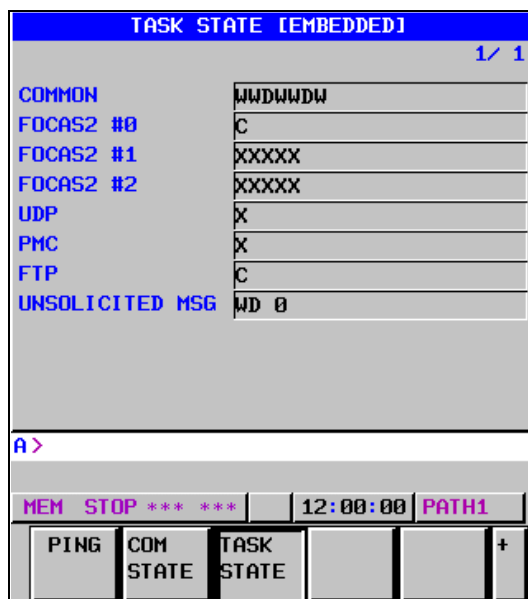

TASK STATE screen

The following symbols are used.

	Symbol and meaning
FOCAS2 #0	C: Waiting for a connection from the host W: Data processing in progress (1) D: Data processing in progress (2) N: FOCAS2 out of service
FOCAS2 #1,#2	W: Data processing in progress (1) D: Data processing in progress (2) X: Not yet executed
UDP	W: Data processing in progress (1) D: Data processing in progress (2) X: Not yet executed
PMC	W: Data processing in progress (1) D: Data processing in progress (2) X: Not yet executed
FTP	C: Execution wait W: Data processing in progress (1) D: Data processing in progress (2) X: Not yet executed
UNSOLICITED MSG	W: Data processing in progress (1) D: Data processing in progress (2) N: Abnormal state X: Not yet executed Number: Alive signal (UDP) transmission in progress when count-up operation is performed

## 7.7 LOG SCREEN OF THE EMBEDDED ETHERNET FUNCTION

This screen displays the log of the embedded Ethernet function.

### NOTE

If alarm SR2032, "EMBEDDED ETHERNET/DATA SERVER ERROR" is issued during data transfer using the embedded Ethernet function, check the error details on the log screen of the embedded Ethernet function.

### Displaying the log screen

#### Procedure

- 1 Press the function key .
- 2 To display the log screen for the embedded Ethernet port or PCMCIA Ethernet card, press soft key [EMBED LOG] or [PCMCIA LOG], respectively. (When there is no soft keys, press the continue key.)

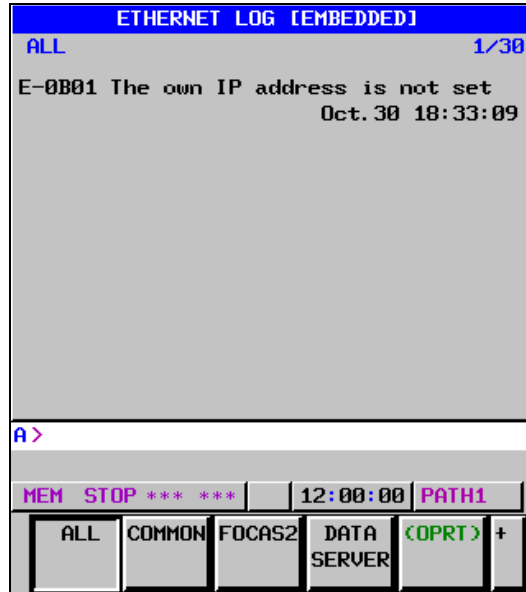

LOG screen

The newest error log appears at the top of the screen. The date and time when an error occurred are displayed at the right end of the line. The format of date and time data is “MMM.DD hh:mm:ss” where MMM represents a month, dd represents a day, hh represents hours, mm represents minutes, and ss represents seconds.

The date and time of the upper item shown above is October 30, 18:33:09.

To clear the log, press soft keys [(OPRT)] and [CLEAR] in that order.



The log for each function can be displayed by using soft keys on the embedded Ethernet log screen.

- (1) Soft key [ALL]  
Displays all log related to the embedded Ethernet.
- (2) Soft key [COMMON]  
Displays the log related to the parameter settings of the embedded Ethernet function and the basic communication function.
- (3) Soft key [FOCAS2]  
Displays the log related to the FOCAS2/Ethernet function.
- (4) Soft key [FTP TRANS]  
Displays the log related to FTP file transfer.
- (5) Soft key [UNSOLT MSG]  
Displays the log related to the unsolicited messaging function.

### Error and message

Error No.	Log message	Description and necessary action
E-0118 E-0119	Error occurred while wait for FOCAS2 pdu	A communication error has occurred because of any of the following: → The network quality has been lowered to such a level that data cannot be received from a PC at the other end. The communication channel has been logically shut down. → Software running on a PC at the other end has logically shut down the communication channel. → The Ethernet cable has been disconnected.

Error No.	Log message	Description and necessary action
E-011A	All communication paths are busy	All the FOCAS2/Ethernet communication channels are busy.
E-0148	Cannot save parameter for Unsolicited Message	<p>When the FOCAS2 function <code>cnc_wrunsolicprm2</code> was received, the parameter for the unsolicited messaging function could not be saved for one of the following causes:</p> <ul style="list-style-type: none"> <li>→ The mode of the unsolicited messaging function is not set to "PC mode".</li> <li>→ The state of the unsolicited messaging function is not "Not Ready".</li> <li>→ The argument "parameter-for-unsolicited-message" of the FOCAS2 function <code>cnc_wrunsolicprm2</code> includes an invalid value.</li> </ul>
E-0149	The received parameter for Unsolicited Message is wrong	When the FOCAS2 function <code>cnc_wrunsolicprm2</code> , <code>cnc_rdunsolicprm2</code> , <code>cnc_unsolicstart</code> , or <code>cnc_unsolicstop</code> was received, the argument "parameter-number-for-unsolicited-message" was found to be invalid.
E-0200	Received message from FTP server	A message sent by the FTP server is directly displayed.
E-0202	Connection failed with FTP server	Software of the FTP server may not be running. Start the software of the FTP server.
E-0207	The router is not found	The specified IP address of the router may be wrong. Alternatively, the router may be turned off. Check whether the IP address of the router has been correctly specified and whether the router is turned on.
E-0208	The FTP server is not found	The specified IP address of the FTP server may be wrong. Alternatively, the FTP server may be turned off. Check whether the IP address of the FTP server has been correctly specified and whether the FTP server is turned on.
E-020B	Cannot login into FTP server	Check whether a correct user name and password are specified when logging into the FTP server.
E-020C	The parameters of FTP server are wrong	Check whether a correct user name and password are specified when logging into the FTP server.
E-020D	Changing a work folder of host failed	Check the work folder logging into the FTP server.
E-041A	Frame transmission failed (TCP)	<p>A communication error has occurred because of any of the following:</p> <ul style="list-style-type: none"> <li>→ The network quality has been lowered to such a level that data cannot be received from a PC at the other end. The communication channel has been logically shut down.</li> <li>→ Software running on a PC at the other end has logically shut down the communication channel.</li> <li>→ The Ethernet cable has been disconnected.</li> </ul>
E-0901	Cannot read MAC address	The MAC address is not written in the hardware. Alternatively, the hardware has been damaged.
E-0A06	Network is too busy	An excessive amount of data is flowing over the network. One possible solution is to divide the network.
E-0B00	The own IP address is wrong	Specify a correct IP address in the designated format.
E-0B01	The own IP address is not set	Specify an IP address.
E-0B02	Subnet mask is wrong	Specify a correct subnet mask in the designated format.
E-0B03	Subnet mask is not set	Specify a subnet mask.
E-0B04	Router IP address is wrong	There may be class disagreement between the IP address of the local node and the IP address of the router.

Error No.	Log message	Description and necessary action
E-0B05	IP address of DNS server is wrong	There may be class disagreement between the IP address of the local node and the IP address of the DNS server.
E-0B06	The own host name is wrong	Check whether a correct host name is specified.
E-0B07	The own domain name is wrong	Check whether a correct domain name is specified.
E-0B08	TCP port number is wrong	A value beyond the permissible setting range may be specified.
E-0B09	UDP port number is wrong	A value beyond the permissible setting range may be specified.
E-0B0B	IP address of remote FTP server is wrong	Specify a correct IP address in the designated format.
E-0B0C	Port No of a remote FTP server is wrong	A value beyond the permissible setting range may be specified.
E-0B0D	User name of remote FTP server is wrong	The specified user name may contain a prohibited character.
E-0B0E	Password of remote FTP server is wrong	The specified password may contain a prohibited character.
E-0B0F	Login folder of remote FTP srv is wrong	The specified log-in folder name may contain a prohibited character.
E-0B18	Cannot set because DHCP is available	To allow a set-up, disable the DHCP client function.
E-0B19 E-0B1A	Embedded Ethernet port isn't found	The software or hardware of embedded Ethernet function cannot be recognized. Check whether the software has been incorporated. Check whether the hardware is sound.
E-0B27	Unsolicited Message function isn't available	The software condition for using the unsolicited messaging function is not satisfied. The cause may be one of the following: → The version of communication software is not supported yet. → NC parameters for using the unsolicited messaging function are not set. For supported versions of communication software and the NC parameters, see Subsection 7.2.4, "Setting of the Unsolicited Messaging Function".
E-0B29	Mode of Unsolicited Message is wrong	In the CNC mode, the FOCAS2 function <code>cnc_wrunsolicprm2</code> cannot be executed.
E-0B2A	Status of Unsolicited Message is wrong	The state of the unsolicited messaging function was other than "Not Ready", so that the parameters for the unsolicited messaging function could not be updated. The cause may be one of the following: → In a state other than "Not Ready", the FOCAS2 function <code>cnc_wrunsolicprm2</code> or <code>cnc_unsolicstart</code> was executed. → In a state other than "Not Ready", soft key [APPLY] was pressed.
E-0B2B	Cannot refresh parameter of Unsolicited Message	The parameters for the unsolicited messaging function could not be updated. The cause may be one of the following: → The problem of E-0B29 or E-0B2A occurred. → A parameter for the unsolicited messaging function includes an invalid value.
E-0B44	Invalid value exists in Transmission parameter of Unsolicited Message	The parameter for the unsolicited messaging function, TRANSMISSION NUMBER or TRANSMISSION PARAMETER (NO. 1 to NO. 3), includes an invalid value.

Error No.	Log message	Description and necessary action
E-0B45	The total of Transmission size of Unsolicited Message exceeds the limitation	The sum of sizes specified by the parameters for the unsolicited messaging function, TRANSMISSION PARAMETER NO. 1 to NO. 3, exceeds the maximum specifiable number of bytes. For the maximum specifiable number of bytes, see the setting item "TRANSMISSION PARAMETER" in Subsection 7.2.4.4, "Setting on the CNC screen".
E-XXXX	(No message)	An internal error has occurred. Make a notification of the error number.



# 8 DIGITAL SERVO

This chapter describes servo tuning screen required for maintenance of digital servo and adjustment of reference position.

- 8.1 INITIAL SETTING SERVO PARAMETERS .....479
- 8.2 FSSB SETTING SCREEN .....489
- 8.3 SERVO TUNING SCREEN .....501
- 8.4 ADJUSTING REFERENCE POSITION (DOG METHOD).....502
- 8.5 DOGLESS REFERENCE POSITION SETTING .....505
- 8.6  $\alpha$ i SERVO WARNING INTERFACE.....506
- 8.7  $\alpha$ i SERVO INFORMATION SCREEN.....509

## 8.1 INITIAL SETTING SERVO PARAMETERS

This section describes how to set initial servo parameters, which is used for field adjustment of machine tool.



1. Turn on power at the emergency stop condition.
2. Set the parameter to display the servo tuning screen.

	#7	#6	#5	#4	#3	#2	#1	#0
3111								SVS

[Input type] Setting input

[Data type] Bit path

- #0 SVS 0: Servo tuning screen is not displayed.
- 1: Servo tuning screen is displayed.

3. Turn off the power once then turn it on again.
4. Display the servo parameter setting screen by the following operation: Function key  →  → [SV.PARA].
5. Input data required for initial setting using the cursor and page key.

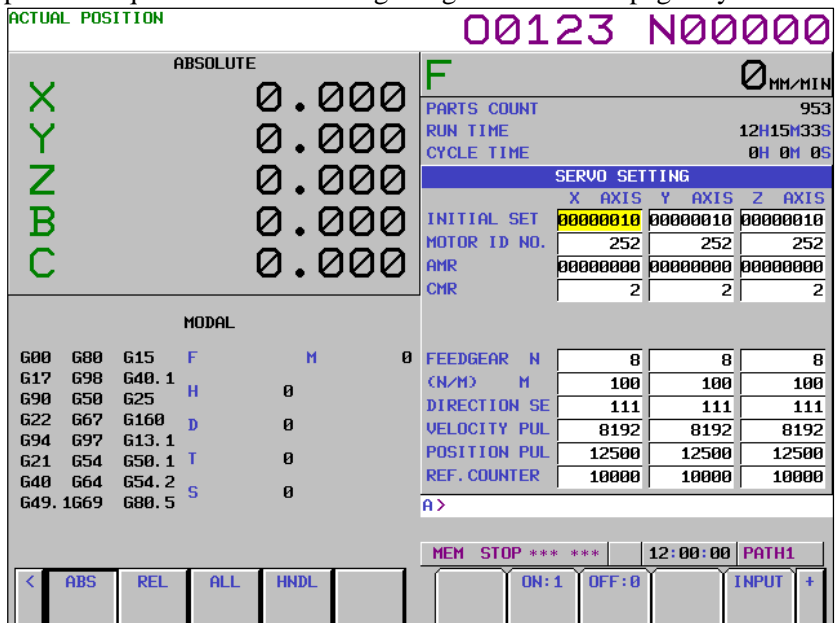

SERVO SETTING		
X AXIS	Y AXIS	Z AXIS
INITIAL SET	00000010	00000010
MOTOR ID NO.	252	252
AMR	00000000	00000000
CHR	2	2
FEEDGEAR	8	8
DIRECTION SE	111	111
VELOCITY PUL	8192	8192
POSITION PUL	12500	12500
REF. COUNTER	10000	10000

- ↔ Parameter No.2000
- ↔ Parameter No.2020
- ↔ Parameter No.2001
- ↔ Parameter No.1820
- ↔ Parameter No.2084
- ↔ Parameter No.2085
- ↔ Parameter No.2022
- ↔ Parameter No.2023
- ↔ Parameter No.2024
- ↔ Parameter No.1821

## (1) Initial set bit

	#7	#6	#5	#4	#3	#2	#1	#0
2000							DGPRM	PLC01

- #0 PLC01** 0: Values of parameters Nos. 2023 and 2024 are used as they are:  
 1: Values of parameters Nos. 2023 and 2024 are multiplied by 10.
- #1 DGPRM** 0: Initial setting of digital servo parameter is done.  
 1: Initial setting of digital servo parameter is not done.

## (2) Motor ID No.

Select the motor ID No. of the servo motor to be used, according to the motor model and drawing number (the middle four digits of A06B-XXXX-BXXX) listed in the tables on subsequent pages.

Table 8.1 (a)  $\alpha$ iS series servo motor

Motor model	Motor specification	Motor type No.	90G0
$\alpha$ iS 2/5000	0212	262	01.0
$\alpha$ iS 2/6000	0218	284	01.0
$\alpha$ iS 4/5000	0215	265	01.0
$\alpha$ iS 4/6000	0210	466	01.0
$\alpha$ iS 8/4000	0235	285	01.0
$\alpha$ iS 8/6000	0232	290	01.0
$\alpha$ iS 12/4000	0238	288	01.0
$\alpha$ iS 12/6000	0230	462	01.0
$\alpha$ iS 22/4000	0265	315	01.0
$\alpha$ iS 22/6000	0262	452	01.0
$\alpha$ iS 30/4000	0268	318	01.0
$\alpha$ iS 40/4000	0272-Bx0x 0272-Bx2x	322	01.0
$\alpha$ iS 50/3000	0275-Bx0x 0275-Bx2x	324	01.0
$\alpha$ iS 50/3000 FAN	0275-Bx1x 0275-Bx3x	325	01.0
$\alpha$ iS 100/2500	0285-Bx0x	335	01.0
$\alpha$ iS 100/2500 FAN	0285-Bx1x	330	01.0
$\alpha$ iS 200/2500	0288-Bx0x	338	01.0
$\alpha$ iS 200/2500 FAN	0288-Bx1x	334	01.0
$\alpha$ iS 300/2000	0292	342	01.0
$\alpha$ iS 500/2000	0295	345	01.0

Loading is possible with the servo software of the series and edition listed above or subsequent editions. The value for an x varies depending on whether an option is provided or not.

Table 8.1 (b)  $\alpha$ iF series servo motor

Motor model	Motor specification	Motor type No.	90G0
$\alpha$ iF 1/5000	0202	252	01.0
$\alpha$ iF 2/5000	0205	255	01.0
$\alpha$ iF 4/4000	0223	273	01.0
$\alpha$ iF 8/3000	0227	277	01.0
$\alpha$ iF 12/3000	0243	293	01.0
$\alpha$ iF 22/3000	0247	297	01.0
$\alpha$ iF 30/3000	0253	303	01.0
$\alpha$ iF 40/3000	0257-Bx0x 0257-Bx2x	307	01.0

Motor model	Motor specification	Motor type No.	90G0
$\alpha iF$ 40/3000 FAN	0257-Bx1x 0257-Bx3x	308	01.0

Loading is possible with the servo software of the series and edition listed above or subsequent editions. The value for an x varies depending on whether an option is provided or not.

Table 8.1 (c)  $\alpha iS$  (HV) series servo motor

Motor model	Motor specification	Motor type No.	90G0
$\alpha iS$ 2/5000HV	0213	263	01.0
$\alpha iS$ 2/6000HV	0219	287	01.0
$\alpha iS$ 4/5000HV	0216	266	01.0
$\alpha iS$ 4/6000HV	0214	467	01.0
$\alpha iS$ 8/4000HV	0236	286	01.0
$\alpha iS$ 8/6000HV	0233	292	01.0
$\alpha iS$ 12/4000HV	0239	289	01.0
$\alpha iS$ 12/6000HV	0237	463	01.0
$\alpha iS$ 22/4000HV	0266	316	01.0
$\alpha iS$ 22/6000HV	0263	453	01.0
$\alpha iS$ 30/4000HV	0269	319	01.0
$\alpha iS$ 40/4000HV	0273-Bx0x 0273-Bx2x	323	01.0
$\alpha iS$ 50/3000HV FAN	0276-Bx1x 0276-Bx3x	326	01.0
$\alpha iS$ 50/3000HV	0276-Bx0x 0276-Bx2x	327	01.0
$\alpha iS$ 100/2500HV	0286-Bx0x	336	01.0
$\alpha iS$ 100/2500HV FAN	0286-Bx1x	331	01.0
$\alpha iS$ 200/2500HV	0289-Bx0x	339	01.0
$\alpha iS$ 200/2500HV FAN	0289-Bx1x	337	01.0
$\alpha iS$ 300/2000HV	0293	343	01.0
$\alpha iS$ 500/2000HV	0296	346	01.0
$\alpha iS$ 1000/2000HV	0298	348	01.0
$\alpha iS$ 1000/2000HV	0098	458	01.0
$\alpha iS$ 2000/2000HV	0091	459	01.0
$\alpha iS$ 3000/2000HV	0092	460	01.0

Loading is possible with the servo software of the series and edition listed above or subsequent editions. The value for an x varies depending on whether an option is provided or not.

Table 8.1 (d)  $\alpha iF$  (HV) series servo motor

Motor model	Motor specification	Motor type No.	90G0
$\alpha iF$ 4/4000HV	0225	275	01.0
$\alpha iF$ 8/3000HV	0229	279	01.0
$\alpha iF$ 12/3000HV	0245	295	01.0
$\alpha iF$ 22/3000HV	0249	299	01.0

Loading is possible with the servo software of the series and edition listed above or subsequent editions.

Table 8.1 (e)  $\alpha Ci$  series servo motor

Motor model	Motor specification	Motor type No.	90G0
$\alpha C4/3000i$	0221	271	01.0
$\alpha C8/2000i$	0226	276	01.0
$\alpha C12/2000i$	0241	291	01.0
$\alpha C22/2000i$	0246	296	01.0

Motor model	Motor specification	Motor type No.	90G0
$\alpha$ C30/1500i	0251	301	01.0

Loading is possible with the servo software of the series and edition listed above or subsequent editions.

**Table 8.1 (f)  $\beta$ iS series servo motor**

Motor model	Motor specification	Motor type No.	90G0
$\beta$ iS 0.2/5000	0111	260	01.0
$\beta$ iS 0.3/5000	0112	261	01.0
$\beta$ iS 0.4/5000	0114	280	01.0
$\beta$ iS 0.5/5000	0115	281	01.0
$\beta$ iS 0.5/6000	0115	281	01.0
$\beta$ iS 1/5000	0116	282	01.0
$\beta$ iS 1/6000	0116	282	01.0
$\beta$ iS 2/4000	0061-Bxx3	253	01.0
$\beta$ iS 2/4000	0061-Bxx6	306	01.0
$\beta$ iS 4/4000	0063-Bxx3	256	01.0
$\beta$ iS 4/4000	0063-Bxx6	311	01.0
$\beta$ iS 8/3000	0075-Bxx3	258	01.0
$\beta$ iS 8/3000	0075-Bxx6	283	01.0
$\beta$ iS 12/2000	0077-Bxx3	269	01.0
$\beta$ iS 12/2000	0077-Bxx6	298	01.0
$\beta$ iS 12/3000	0078	272	01.0
$\beta$ iS 22/1500	0084	302	01.0
$\beta$ iS 22/2000	0085	274	01.0
$\beta$ iS 22/3000	0082	313	01.0
$\beta$ iS 22/2000	0085	274	01.0

Loading is possible with the servo software of the series and edition listed above or subsequent editions.

**Table 8.1 (g)  $\beta$ iS (HV) series servo motor**

Motor model	Motor specification	Motor type No.	90G0
$\beta$ iS 2/4000HV	0062	251	01.0
$\beta$ iS 4/4000HV	0064	264	01.0
$\beta$ iS 8/3000HV	0076	267	01.0
$\beta$ iS 12/3000HV	0079	270	01.0
$\beta$ iS 22/2000HV	0086	278	01.0
$\beta$ iS 22/3000HV	0083	314	01.0

Loading is possible with the servo software of the series and edition listed above or subsequent editions.

**Table 8.1 (h) LiS series linear motor**

**Note: The following linear motors are driven by 200V.**

Motor model	Motor specification	Motor type No.	90G0
LiS 300A1/4	0441-B200	351	01.0
LiS 600A1/4	0442-B200	353	01.0
LiS 900A1/4	0443-B200	355	01.0
LiS 1500B1/4	0444-B2x0	357	01.0
LiS 3000B2/2	0445-B1x0	360	01.0
LiS 3000B2/4	0445-B2x0	362	01.0
LiS 4500B2/2	0446-B1x0	364	01.0
LiS 6000B2/2	0447-B1x0	368	01.0

Motor model	Motor specification	Motor type No.	90G0
LiS 6000B2/4	0447-B2x0	370	01.0
LiS 7500B2/2	0448-B1x0	372	01.0
LiS 9000B2/2	0449-B1x0	376	01.0
LiS 9000B2/4	0449-B210	378	01.0
LiS 3300C1/2	0451-B1x0	380	01.0
LiS 9000C2/2	0454-B1x0	384	01.0
LiS 11000C2/2	0455-B1x0	388	01.0
LiS 15000C2/2	0456-B1x0	392	01.0
LiS 15000C2/3	0456-B2x0	394	01.0
LiS 10000C3/2	0457-B1x0	396	01.0
LiS 17000C3/2	0459-B1x0	400	01.0

Note: The following linear motors are driven by 400V.

Motor model	Motor specification	Motor type No.	90G0
LiS 1500B1/4	0444-B2x0	358	01.0
LiS 3000B2/2	0445-B1x0	361	01.0
LiS 4500B2/2HV	0446-B0x0	363	01.0
LiS 4500B2/2	0446-B1x0	365	01.0
LiS 6000B2/2HV	0447-B0x0	367	01.0
LiS 6000B2/2	0447-B1x0	369	01.0
LiS 7500B2/2HV	0448-B0x0	371	01.0
LiS 7500B2/2	0448-B1x0	373	01.0
LiS 9000B2/2	0449-B1x0	377	01.0
LiS 3300C1/2	0451-B1x0	381	01.0
LiS 9000C2/2	0454-B1x0	385	01.0
LiS 11000C2/2HV	0455-B0x0	387	01.0
LiS 11000C2/2	0455-B1x0	389	01.0
LiS 15000C2/3HV	0456-B0x0	391	01.0
LiS 10000C3/2	0457-B1x0	397	01.0
LiS 17000C3/2	0459-B1x0	401	01.0

Loading is possible with the servo software of the series and edition listed above or subsequent editions.

Table 8.1 (i) DiS synchronous built-in servo motor

Note: The following synchronous built-in servo motors are driven by 200V.

Motor model	Motor specification	Motor type No.	90G0
DiS 22/600	0482-B10x	421	01.0
DiS 85/400	0483-B20x	423	01.0
DiS 85/1000	0483-B224	443	01.0
DiS 110/300	0484-B10x	425	01.0
DiS 110/1000	0484-B12x	445	01.0
DiS 260/300	0484-B30x	427	01.0
DiS 260/600	0484-B31x	429	01.0
DiS 260/1000	0484-B324	447	01.0
DiS 370/300	0484-B40x	431	01.0
DiS 1200/250	0485-B50x	435	01.0
DiS 1500/200	0486-B30x	437	01.0
DiS 2100/150	0487-B30x	439	01.0
DiS 3000/150	0487-B40x	441	01.0

Note: The following synchronous built-in servo motors are driven by 400V.

Motor model	Motor specification	Motor type No.	90G0
DiS 22/600	0482-B10x	422	01.0
DiS 85/400	0483-B20x	424	01.0
DiS 110/300	0484-B10x	426	01.0
DiS 260/300	0484-B30x	428	01.0
DiS 260/600	0484-B31x	430	01.0
DiS 370/300	0484-B40x	432	01.0
DiS 1200/250	0485-B50x	436	01.0
DiS 1500/200	0486-B30x	438	01.0
DiS 2100/150	0487-B30x	440	01.0
DiS 3000/150	0487-B40x	442	01.0

Loading is possible with the servo software of the series and edition listed above or subsequent editions.

(3) Arbitrary AMR function

	#7	#6	#5	#4	#3	#2	#1	#0	(Axis)
2001	AMR7	AMR6	AMR5	AMR4	AMR3	AMR2	AMR1	AMR0	

\* Set "00000000".

(4) CMR

1820	Command multiply ratio
------	------------------------

1) When CMR is 1/2 to 1/27

$$\text{Set value} = \frac{1}{\text{CMR}} + 100$$

2) When CMR is 0.5 to 48

$$\text{Set value} = 2 \times \text{CMR}$$

1822	Value of the numerator of arbitrary command multiplier n/m
------	--

1823	Value of the denominator of arbitrary command multiplier n/m
------	--

To set an arbitrary command multiplier, the corresponding option is required.

(5) Turn off the power then back on.

(6) N/M of feed gear (F·FG)

2084	n for flexible feed gear
------	--------------------------

2085	m for flexible feed gear
------	--------------------------

Setting for the α Pulsecoder in the semi-closed mode	
$\frac{\text{F·FG numerator } (\leq 32767)}{\text{F·FG denominator } (\leq 32767) \text{ (Note 1)}}$	$= \frac{\text{Necessary position feedback pulses per motor revolution}}{1,000,000 \text{ (Note 2)}} \text{ (as irreducible fraction)}$

**NOTE**

1 For both F·FG number and denominator, the maximum setting value (after reduced) is 32767.

**NOTE**

2  $\alpha_i$  Pulsecoders assume one million pulses per motor revolution, irrespective of resolution, for the flexible feed gear setting.

3 If the calculation of the number of pulses required per motor revolution involves  $p$ , such as when a rack and pinion are used, assume  $\pi$  to be approximately 355/113.

[Example] For detection in 1 mm units, specify as follows:

Ball screw lead (mm/rev)	Number of necessary position pulses (pulses/rev)	F-FG
10	10000	1/100
20	20000	2/100 or 1/50
30	30000	3/100

[Example]

If the machine is set to detection in 1,000 degree units with a gear reduction ratio of 10:1 for the rotation axis, the table rotates by 360/10 degrees each time the motor makes one turn.

1000 position pulses are necessary for the table to rotate through one degree.

The number of position pulses necessary for the motor to make one turn is:

$$360/10 \times 1000 = 36000 \text{ with reference counter} = 36000$$

$$\frac{\text{F-FG numerator}}{\text{F-FG denominator}} = \frac{36000}{1,000,000} = \frac{36}{1000}$$

Additional F-FG (numerator/denominator) examples with a reduction ratio of 1:1

Detection unit	Ball screw lead					
	6mm	8mm	10mm	12mm	16mm	20mm
1 $\mu$ m	6 / 1000	8 / 1000	10 / 1000	12 / 1000	16 / 1000	20 / 1000
0.5 $\mu$ m	12 / 1000	16 / 1000	20 / 1000	24 / 1000	32 / 1000	40 / 1000
0.1 $\mu$ m	60 / 1000	80 / 1000	100 / 1000	120 / 1000	160 / 1000	200 / 1000

Setting for use of a separate detector (full-closed)

$$\frac{\text{F-FG numerator } (\leq 32767)}{\text{F-FG denominator } (\leq 32767)} = \frac{\text{Number of position pulses corresponding to a predetermined amount of travel}}{\text{Number of position pulses corresponding to a predetermined amount of travel from a separate detector}} \text{ (as irreducible fraction)}$$

[Example]

To detect a distance of 1  $\mu$ m using a 0.5  $\mu$ m scale, set the following:

$$\frac{\text{Numerator of F-FG}}{\text{Denominator of F-FG}} = \frac{L/1}{L/0.5} = \frac{1}{2}$$

**Other F-FG (numerator/denominator) setting examples**

Detection unit	Resolution of scale			
	1 $\mu$ m	0.5 $\mu$ m	0.1 $\mu$ m	0.05 $\mu$ m
1 $\mu$ m	1/1	1/2	1/10	1/20
0.5 $\mu$ m	—	1/1	1/5	1/10
0.1 $\mu$ m	—	—	1/1	1/2

(7) Direction of travel

<b>2022</b>	<b>Rotational direction of motor</b>
-------------	--------------------------------------

111 : Normal (clockwise)    -111 : Reverse (counterclockwise)

(8) Number of speed pulses, Number of position pulses

	Semi-closed loop	Closed loop		
		Parallel type	Serial linear scale	Serial rotary scale
Command unit ( $\mu\text{m}$ )	1/0.1	1/0.1	1/0.1	1/0.1
Initial bit setting	b0=0	b0=0	b0=0	b0=0
Number of speed pulses	8192	8192	8192	8192
Number of position pulses	12500(*1)	(*2 - Example 1)	(*2 - Example 1)	(*2 - Example 2)

Set 8192 as the number of speed pulses. For the linear motor, make settings according to "Linear Motor Parameter Setting" in the  $\alpha i$  series parameter manual.

#### NOTE

- Setting of the number of position pulses for the semi-closed loop (indicated by (\*1) in the above table)  
Set 12500.
- As the number of position pulses, set the number of pulses fed back from a separate detector when the motor makes one revolution. (The flexible feed gear has no relevance to the calculation of the number of position pulses.)

Example 1:

When a ball screw (direct connection) with a 10-mm lead and a separate detector with a resolution of 0.5  $\mu\text{m}$  per pulse are used

When the motor makes one revolution, the following pulses are fed back from the separate detector:

$$10/0.0005 = 20,000$$

Accordingly,

$$\text{Number of position pulses} = 20,000$$

Example 2:

When a serial rotary scale with a resolution of 1,000,000 pulses per revolution is used, the number of position feedback pulses is exceptionally calculated by the following:

$$12500 \times (\text{deceleration ratio between the motor and table})$$

When the deceleration ratio between the motor and table is 10:1, for example, the number of position pulses is:

$$12,500 \times (1/10) = 1250$$

- When the set number of position pulses is greater than 32767  
Set position pulses, using the conversion coefficient for the number of position feedback pulses, as follows:

With a position feedback pulse conversion coefficient, the number of position pulses is set using the product of two parameters.

2024	Number of position pulses
2185	Conversion coefficient for the number of position feedback pulses

(Example of setting)

When a linear scale with a minimum resolution of 0.1 (m is used and the travel distance per motor revolution is 16 mm:

$$N_s = (\text{travel distance per motor revolution (mm)}) / (\text{minimum resolution of detector (mm)}) \\ = 16 \text{ mm} / 0.0001 \text{ mm} = 160000 (>32767) = 10000 \times 16$$

So, set the following:

A: 10000

B: 16



**NOTE**  
 If the detector of the motor is an  $\alpha i$  pulse coder (the number of speed pulses = 8192), select a power of 2 (such as 2, 4, 8, and so on) as a conversion coefficient whenever possible. (The position gain value used inside the software becomes more accurate.)

(9) Reference counter

1821	Reference counter capacity for each axis (0 to 99999999)
------	--

(a) For the semi-closed loop

Reference counter = Number of position pulses required per motor revolution or the same number divided by an integer

**NOTE**  
 If the rotation ratio between the motor and table is not an integer when a rotation axis is used, a reference counter capacity needs to be set so that the point where reference counter = 0 (grid point) always appears at the same position relative to the table.

Example of setting)  
 $\alpha i$  Pulsecoder, semi-closed loop (1  $\mu$ m detection)

Lead of ball screw (mm/revolution)	Required number of position pulses (pulses/revolution)	Reference counter	Grid width (mm)
10	10000	10000	10
20	20000	20000	20
30	30000	30000	30

If there is an error between the required number of position pulses per motor revolution and the setting of the reference counter, the reference position varies, depending on the start point. Such an error needs to be eliminated by changing the detection unit. In this case, a reference counter capacity may be set using a fraction.

Example of setting)

System with detection unit = 1  $\mu$ m, ball screw lead = 20 mm/revolution, and deceleration ratio = 1/17

- (i) Method of setting a reference counter capacity as a fraction  
 Required number of position pulses per motor revolution = 20000/17  
 Set the parameters as follows:

1821	Reference counter capacity of each axis (numerator) (0 to 99999999)
------	---

2179	Reference counter capacity of each axis (denominator) (0 to 100)
------	--

The parameter for a denominator is not presently displayed on the servo screen. So, a denominator needs to be set on the parameter screen.  
 In this example, set numerator = 20000, and denominator = 17.

**NOTE**

The reference counter assumes only an integer. So, if a fraction is set for a reference counter capacity, the gap to the point where reference counter = 0 is compensated for.

(In pulse control theory, a position less than one pulse cannot be controlled. So, grid interval compensation is performed so that a grid point error is less than one detection unit at all times.)

## (ii) Method of changing the detection unit

Required number of position pulses per motor revolution = 20000/17

The values of all of the following parameters are multiplied by 17 to change the detection unit to 1/17  $\mu\text{m}$ :

Parameter to be changed	Series 30i
FFG $\times$ 17	Servo screen
CMR $\times$ 17	Servo screen
Reference counter $\times$ 17	Servo screen
Effective area $\times$ 17	No. 1826, 1827
Positional deviation limit value during movement $\times$ 17	No. 1828
Positional deviation limit value during a stop $\times$ 17	No. 1829
Backlash amount $\times$ 17	No. 1851, 1852

As the detection unit is changed from 1  $\mu\text{m}$  to 1/17  $\mu\text{m}$ , the values of all parameters to be set using the detection unit must be multiplied by 17.

**CAUTION**

In addition to the parameters listed above, there are parameters to be set using the detection unit.

This change eliminates an error between the required number of position pulses per motor revolution and the reference counter.

Required number of position pulses per motor revolution = 20000

Reference counter = 20000

## (b) For the closed loop

Reference counter = Z phase (reference position) interval/detection unit or the same number divided by an integer

If the reference counter does not assume an integer, see the example of semi-closed loop.

**NOTE**

If the rotation ratio between the separate detector and table is not an integer when a rotation axis is used, a reference counter capacity needs to be set so that the point where reference counter = 0 (grid point) always appears at the same position relative to the table.

Example of setting)

Example 1)

When Z phase interval = 50 mm and detection unit = 1  $\mu\text{m}$

Reference counter = 50,000/1 = 50,000

Example 2)

When detection unit = 0.001° with a rotation axis

Reference counter = 360/0.001 = 360,000

## Example 3)

When there is only one Z phase as in the case of a linear scale  
Set a simple number such as 10000 and 50000 for the reference counter.

6. Turn off the power then back on.



## 8.2 FSSB SETTING SCREEN

Connecting the CNC control unit to servo amplifiers via a high-speed serial bus (FANUC Serial Servo Bus, or FSSB), which uses only one fiber optics cable, can significantly reduce the amount of cabling in machine tool electrical sections.

Axis settings are calculated automatically according to the interrelationships between axes and amplifiers entered on the FSSB setting screen. Parameters Nos. 1023, 2013#0, 2014#0, 3717, 11802#4, 24000 to 24095, and 24096 to 24103 are specified automatically according to the results of the calculation.

### Display

The FSSB setting screen displays FSSB-based amplifier and axis information. This information can also be specified by the operator.

- 1 Press function key .
- 2 To display [FSSB], press continuous menu key  several times.
- 3 Pressing the soft key [FSSB] causes the [CONNECTION STATUS] screen (or the previously selected FSSB setting screen) to appear, with the following soft keys displayed.

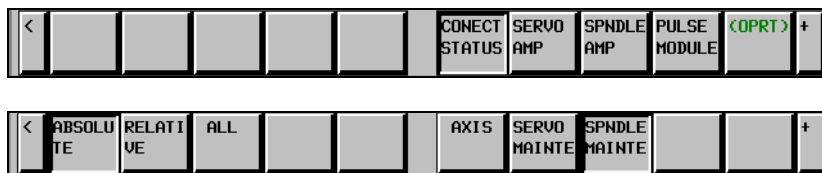

There are seven FSSB setting screens: [CONNECTION STATUS], [SERVO AMPLIFIER SETTING], [SPINDLE AMPLIFIER SETTING], [SEPARATE DETECTOR INTERFACE UNIT], [AXIS SETTING], [SERVO AMPLIFIER MAINTENANCE], and [SPINDLE AMPLIFIER MAINTENANCE].

Pressing the soft key [CONECT STATUS] causes the [CONNECTION STATUS] screen to appear.

Pressing the soft key [SERVO AMP] causes the [SERVO AMPLIFIER SETTING] screen to appear.

Pressing the soft key [SPNDLE AMP] causes the [SPINDLE AMPLIFIER SETTING] screen to appear.

Pressing the soft key [PULSE MODULE] causes the [SEPARATE DETECTOR INTERFACE UNIT] screen to appear.

Pressing the soft key [AXIS] causes the [AXIS SETTING] screen to appear.

Pressing the soft key [SERVO MAINTENANCE] causes the [SERVO AMPLIFIER MAINTENANCE] screen to appear.

Pressing the soft key [SPNDLE MAINTENANCE] causes the [SPINDLE AMPLIFIER MAINTENANCE] screen to appear.

(1) Connection status screen

The connection status screen displays the connection status of slaves connected to the FSSB at power-on.

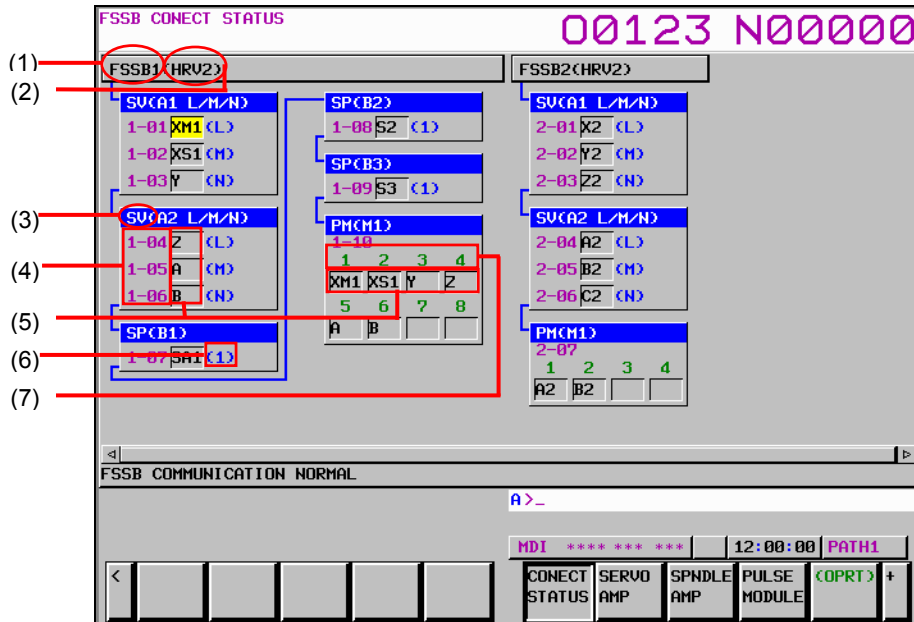

The connection status screen displays the following items:

- <1> FSSB1,FSSB2,FSSB3 ..... FSSB line number  
The FSSB line number is displayed. (FSSB1: First FSSB line, FSSB2: Second FSSB line, FSSB3: Third FSSB line)
- <2> HRV2,HRV3,HRV4,HRV- ..... Current loop  
The current loop for each FSSB line is displayed. "HRV-" may be displayed when no servo amplifier is connected to the FSSB or an FSSB-related alarm is issued.
- <3> SV,SP,PM ..... Slave type  
The type of slave connected to the FSSB is displayed. (SV: Servo amplifier, SP: Spindle amplifier, PM: Separate detector interface unit)
- <4> 1-01 to 1-32, 2-01 to 2-32, 3-01 to 3-32 ..... Slave number  
An FSSB line number (1: First FSSB line, 2: Second FSSB line, 3: Third FSSB line), a hyphen (-), and a slave number (connection number for the line) are displayed. (The maximum number of slaves per line is 32.)
- <5> XM1,XS1,Y,Z,A,B ..... Program axis name, Spindle name  
The program axis name or spindle name set for each amplifier or separate detector interface unit is displayed.
- <6> L,M,N,1 ..... Amplifier axis order  
The axis order for each amplifier is displayed. (L: First axis for a servo amplifier, M: Second axis for a servo amplifier, N: Third axis for a servo amplifier, 1: First spindle for a spindle amplifier)
- <7> 1 to 8 ..... Connector number  
The connector number of a separate detector interface unit is displayed.

(2) Servo amplifier setting screen

The servo amplifier setting screen displays servo amplifier information.

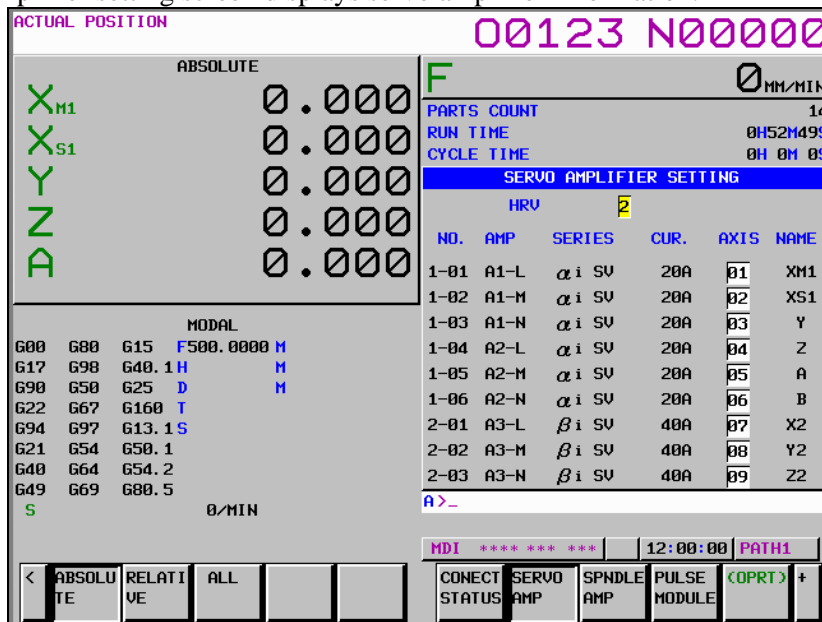

The servo amplifier setting screen consists of the following items:

- **HRV** ..... Current loop  
The current loop to be set at FSSB automatic setting is displayed. This value does not indicate the current effective current loop. (2: Servo HRV2 control, 3: Servo HRV3 control, 4: Servo HRV4 control)
- **NO.** ..... Slave number  
An FSSB line number (1: First FSSB line, 2: Second FSSB line, 3: Third FSSB line), a hyphen (-), and a slave number (connection number for the line) are displayed. (The maximum number of slaves per line is 32.)
- **AMP** ..... Amplifier type  
This consists of the letter A, which stands for “servo amplifier”, a number indicating the placing of the servo amplifier, as counted from that nearest to the CNC, and an alphabetic character indicating the axis order in the servo amplifier (L: First axis, M: Second axis, N: Third axis).
- The following items are displayed as servo amplifier information:
  - **SERIES** ..... Servo amplifier type and series
  - **CUR.** ..... Maximum rating current
- **AXIS** ..... Controlled axis number  
The controlled axis number assigned to the servo amplifier is displayed. “0” is displayed if an FSSB-related alarm is issued or no controlled axis number is assigned.
- **NAME** ..... Program axis name  
The program axis name corresponding to a particular controlled axis number set in parameter No. 1020 is displayed. When the axis number is 0, nothing is displayed.

(3) Spindle amplifier setting screen

The spindle amplifier setting screen displays spindle amplifier information.

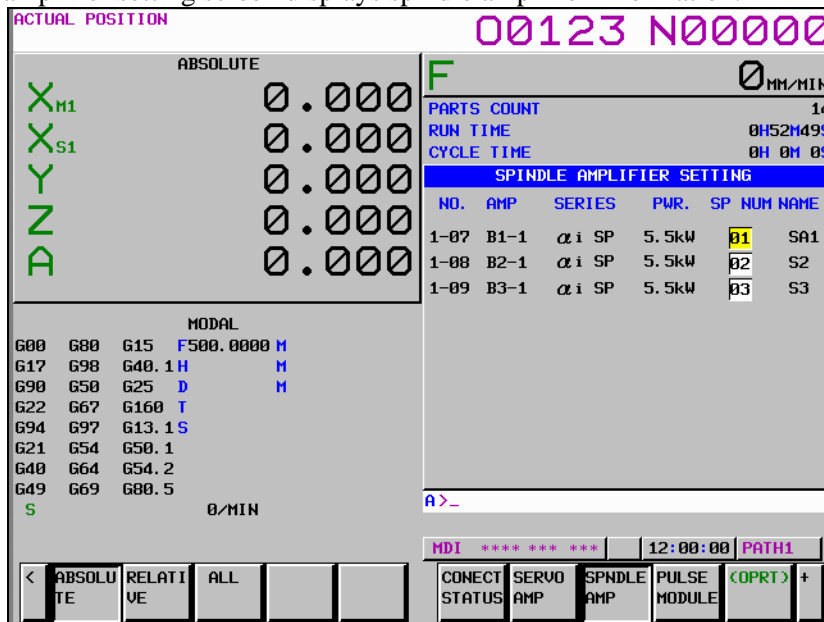

The spindle amplifier setting screen consists of the following items:

- NO.....Slave number  
An FSSB line number (1: First FSSB line, 2: Second FSSB line, 3: Third FSSB line), a hyphen (-), and a slave number (connection number for the line) are displayed. (The maximum number of slaves per line is 32.)
- AMP.....Amplifier type  
This consists of the letter B, which stands for “spindle amplifier”, a number indicating the placing of the spindle amplifier, as counted from that nearest to the CNC, and an alphabetic character indicating the axis order in the spindle amplifier (1: First spindle for a spindle amplifier).
- The following items are displayed as spindle amplifier information:
  - SERIES.....Spindle amplifier type and series
  - PWR.....Maximum output
- SP NUM.....Spindle number  
The spindle number assigned to the spindle amplifier is displayed. “0” is displayed if an FSSB-related alarm is issued or no spindle number is assigned.
- NAME.....Spindle name  
The spindle name corresponding to the spindle number is displayed. When the spindle number is 0, nothing is displayed.

(4) Separate detector interface unit screen

The separate detector interface unit screen displays information on separate detector interface units.

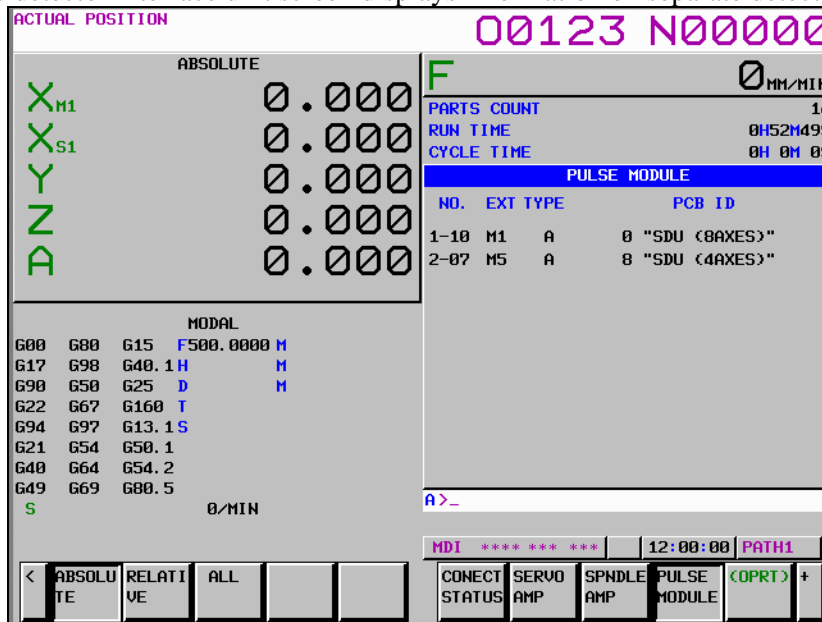

The separate detector interface unit screen displays the following items:

- NO.....Slave number  
An FSSB line number (1: First FSSB line, 2: Second FSSB line, 3: Third FSSB line), a hyphen (-), and a slave number (connection number for the line) are displayed. (While the maximum number of slaves per line is 32, the maximum number of separate detector interface units per line is 4.)
- The following items are displayed as separate detector interface unit information:
  - EXT  
This consists of the letter M, which stands for "separate detector interface unit", and a number indicating the placing of the separate detector interface unit, as counted from that nearest to the CNC. For the second FSSB line, M5 is displayed for the first separate detector interface unit since the number starts from 5. For the third FSSB line, M9 is displayed for the first separate detector interface unit since the number starts from 9.
  - TYPE  
This is a letter indicating the type of the separate detector interface unit.
  - PCB ID  
The ID of the separate detector interface unit is displayed.  
The separate detector interface unit ID is followed by SDU (8AXES) when 8-axes separate detector interface unit or SDU (4AXES) when 4-axes separate detector interface unit.

## (5) Axis setting screen

The axis setting screen displays the information of axis.

AXIS	NAME	AMP	M	CS	M/S
1	XM1	1-A1-L	0	00	00
2	XS1	1-A1-M	0	00	00
3	Y	1-A1-N	0	00	00
4	Z	1-A2-L	0	00	00
5	A	1-A2-M	0	00	00
6	B	1-A2-N	0	00	00
7	X2	2-A3-L	0	00	00
8	Y2	2-A3-M	0	00	00
9	Z2	2-A3-N	0	00	00
10	A2	2-A4-L	0	00	00



The axis setting screen displays the following items. Any item that cannot be set is not displayed. (When the first and fifth separate detector interface units are connected and Cs contour control and tandem control can be used, the screen shown in above figure is displayed.)

- **AXIS**.....Controlled axis number  
This item is the placing of the NC controlled axis.
- **NAME**.....Program axis name for each axis
- **AMP**.....FSSB line number and amplifier type of the servo amplifier connected to each axis
- **M1**.....Connector number of the first or ninth (first unit for the third FSSB line) separate detector interface unit
- **M2**.....Connector number of the second or tenth separate detector interface unit
- **M3**.....Connector number of the third or eleventh separate detector interface unit
- **M4**.....Connector number of the fourth or twelfth separate detector interface unit
- **M5**.....Connector number of the fifth (first unit for the second FSSB line) separate detector interface unit
- **M6**.....Connector number of the sixth separate detector interface unit
- **M7**.....Connector number of the seventh separate detector interface unit
- **M8**.....Connector number of the eighth separate detector interface unit  
Connector numbers set by FSSB automatic setting are displayed.
- **Cs**.....Cs contour controlled axis  
The spindle number for the Cs contour controlled axis set by FSSB automatic setting is displayed.
- **M/S**.....Master axis / Slave axis (Slave axis / Dummy axis)  
Either of the following settings is displayed: Master axis/slave axis setting for tandem control or slave axis/dummy axis setting for the electronic gear box (EGB) set by FSSB automatic setting.

The M1 to M8, Cs, and M/S values are to be set by FSSB automatic setting and do not indicate current effective settings. The previous values set normally are displayed first after power-on. "0" is displayed when an FSSB-related alarm is issued.



(6) Servo amplifier maintenance screen

The servo amplifier maintenance screen displays maintenance information for servo amplifiers. This screen consists of the following two pages, either of which can be selected by pressing the cursor keys  and .

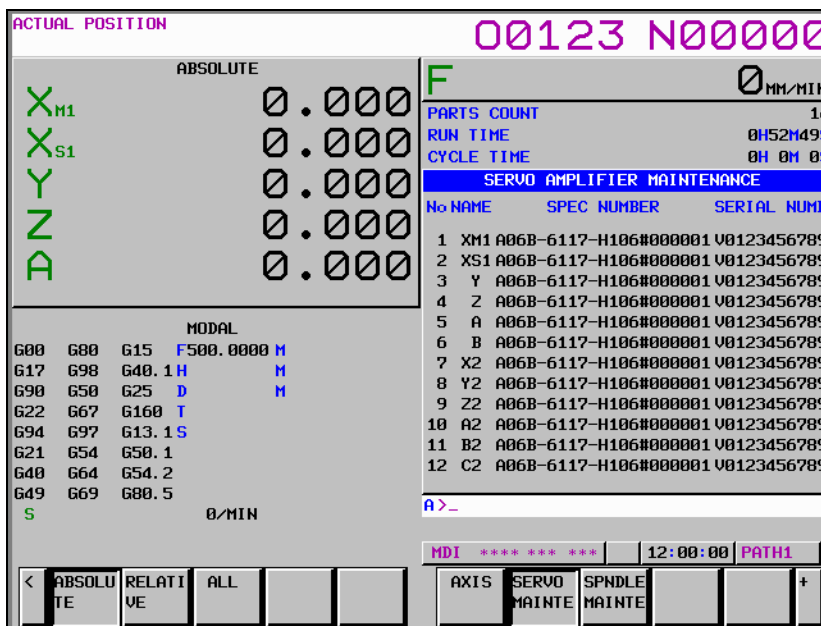
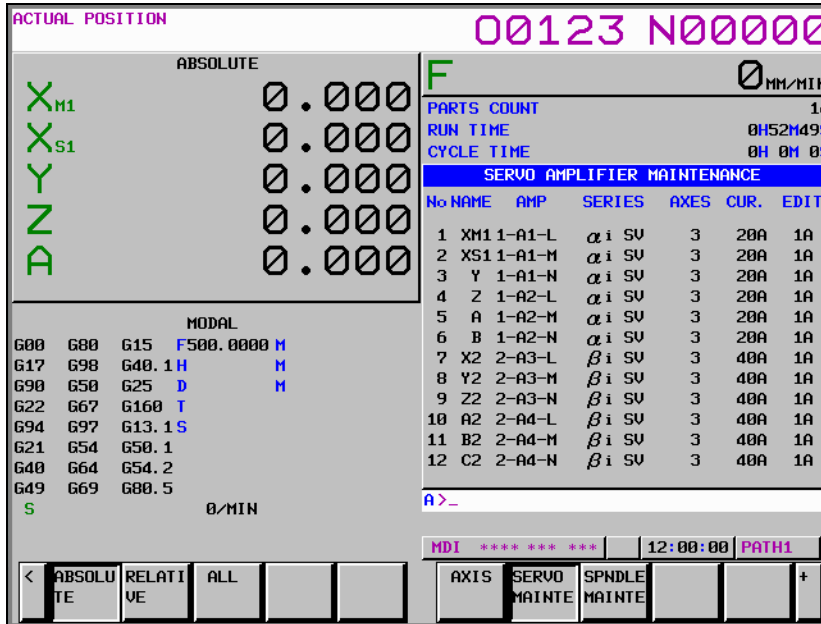



The servo amplifier maintenance screen displays the following items:

- No..... Controlled axis number
- NAME..... Program axis name for each axis
- AMP..... FSSB line number and amplifier type of the servo amplifier connected to each axis
- SERIES ..... Type and series of the servo amplifier connected to each axis
- AXES ..... Maximum number of axes controlled by a servo amplifier connected to each axis
- CUR. .... Maximum rating current for servo amplifiers connected to each axis
- EDIT ..... Version number of a servo amplifier connected to each axis

- SPEC NUMBER. Amplifier drawing number of the servo amplifier connected to each axis
- SERIAL NUMB.. Serial number of the servo amplifier connected to each axis

(7) Spindle amplifier maintenance screen

The spindle amplifier maintenance screen displays maintenance information for spindle amplifiers. This screen consists of the following two pages, either of which can be selected by pressing the cursor keys  and .

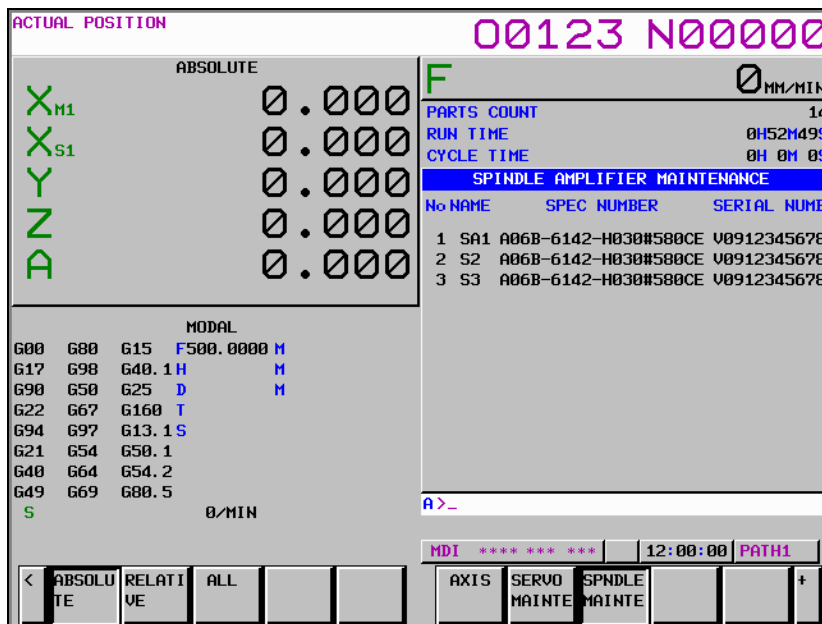
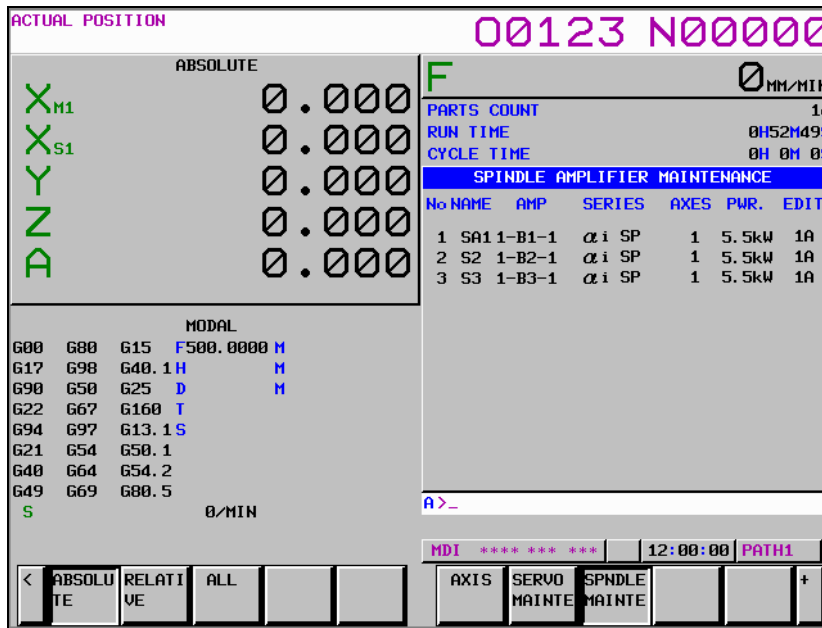

The spindle amplifier maintenance screen displays the following items:

- No..... Spindle number
- NAME..... Spindle name
- AMP..... FSSB line number and amplifier type of the spindle amplifier connected to each axis
- SERIES ..... Type and series of the spindle amplifier connected to each axis

- AXES..... Maximum number of axes controlled by a spindle amplifier connected to each axis
- PWR..... Rated output of the spindle amplifier connected to each axis
- EDIT ..... Version number of a servo amplifier connected to each axis
- SPEC NUMBER. Amplifier drawing number of the spindle amplifier connected to each axis
- SERIAL NUMB.. Serial number of the spindle amplifier connected to each axis

### FSSB automatic setting procedure

To perform FSSB automatic setting, set items on the FSSB setting screens in (1) to (3) below.

(1) Servo amplifier setting screen

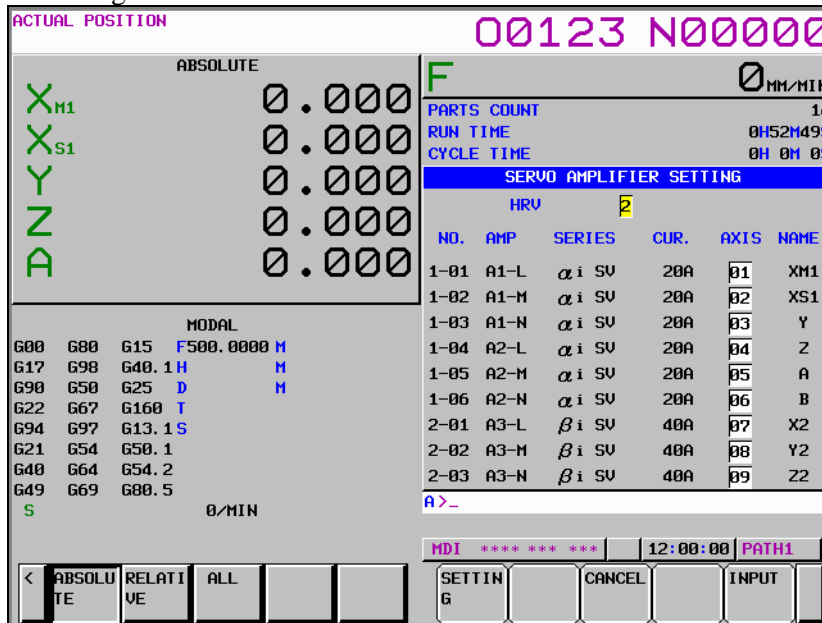

The servo amplifier setting screen displays the following items:

- HRV ..... Current loop  
For this item, enter a value between 2 to 4.  
If a number that falls outside this range is entered, the warning message, "DATA IS OUT OF RANGE" appears.
- AXIS ..... Controlled axis number  
For this item, enter a value of between 0 and the maximum number of controlled axes.  
If a number that falls outside this range is entered, the warning message, "DATA IS OUT OF RANGE" appears. Setting 0 means that the relevant servo amplifier is not used.

(2) Spindle amplifier setting screen

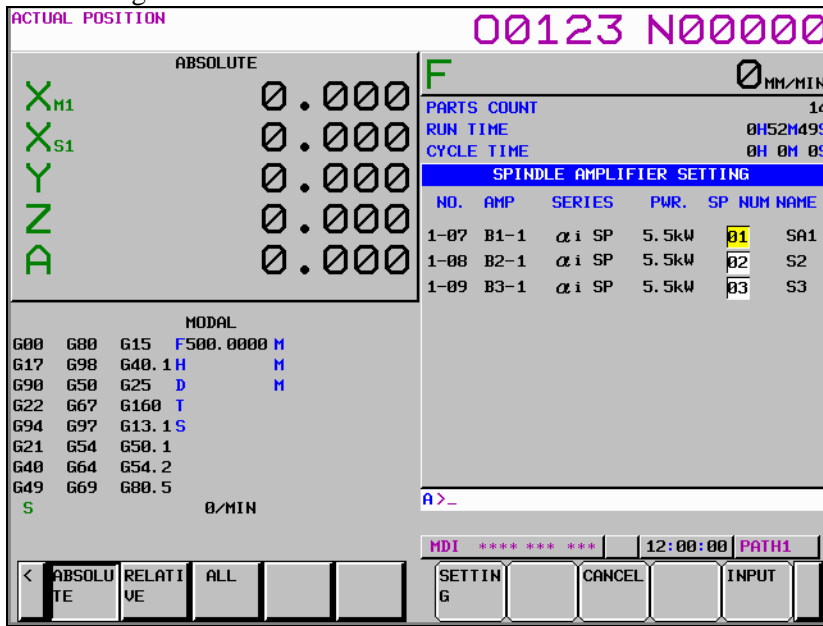

The spindle amplifier setting screen displays the following items:

- SP NUM..... Spindle number  
For this item, enter a value of between 0 and the maximum number of spindles.  
If a number that falls outside this range is entered, the warning message, “DATA IS OUT OF RANGE” appears. Setting 0 means that the relevant spindle amplifier is not used.

(3) Axis setting screen

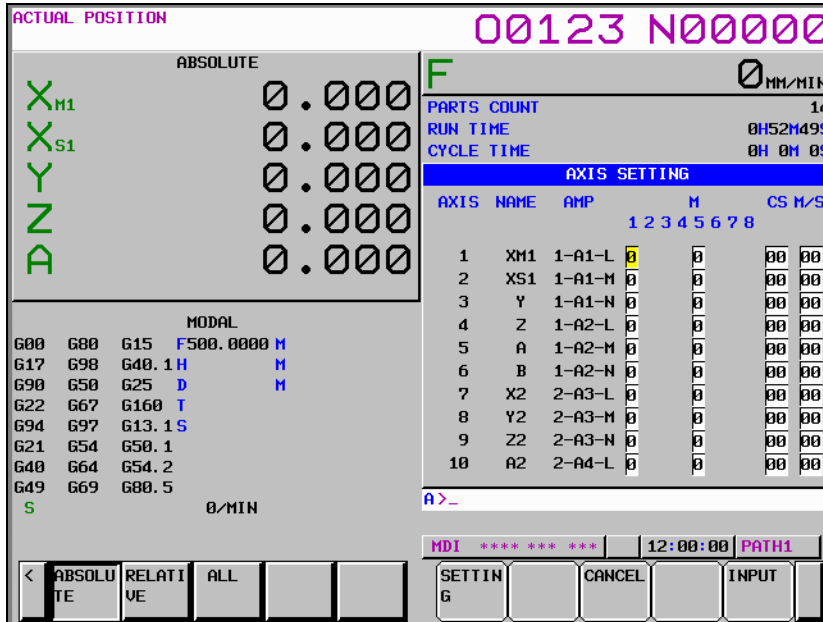

On the axis setting screen, the following items can be specified:

- M1 ..... Connector number of the first or ninth (first unit for the third FSSB line) separate detector interface unit
- M2 ..... Connector number of the second or tenth separate detector interface unit
- M3 ..... Connector number of the third or eleventh separate detector interface unit
- M4 ..... Connector number of the fourth or twelfth separate detector interface unit
- M5 ..... Connector number of the fifth (first unit for the second FSSB line) separate detector interface unit

- M6..... Connector number of the sixth separate detector interface unit
  - M7..... Connector number of the seventh separate detector interface unit
  - M8..... Connector number of the eighth separate detector interface unit
- For an axis that uses each separate detector interface unit, enter a connector number using a number 1 to 8 (maximum number of connectors on a separate detector interface unit).  
 When a separate detector interface unit is not used, enter 0. If a number that falls outside this range is entered, the warning message, “DATA IS OUT OF RANGE” appears. For a separate detector interface unit which is not connected, items are not displayed and values cannot be entered.

Connector	Connector number
JF101	1
JF102	2
JF103	3
JF104	4
JF105	5
JF106	6
JF107	7
JF108	8

- CS..... Cs contour controlled axis  
 Enter a spindle number between 1 and the maximum number of spindles for the Cs contour controlled axis. When a Cs contour controlled axis is not used, enter 0. If a number that falls outside this range is entered, the warning message, “DATA IS OUT OF RANGE” appears. When Cs contour control cannot be used, this item is not displayed and any value cannot be entered.
- M/S..... Master axis / Slave axis (Slave axis / Dummy axis)  
 Enter an odd number for the master axis and an even number for the slave axis for tandem control. These numbers must be consecutive and within a range between 1 and the maximum number of controlled axes. Enter an odd number for the slave axis and an even number for the dummy axis for the electronic gear box (EGB). These numbers must be consecutive and within a range between 1 and the maximum number of controlled axes. If a number that falls outside this range is entered, the warning message, “DATA IS OUT OF RANGE” appears. For the slave and dummy axes for EGB, set bit 0 (SYN) of parameter No. 2011 to 1. When both tandem control and electronic gear box cannot be used, this item is not displayed and any value cannot be entered.

On an FSSB setting screen (other than the connection status screen, servo amplifier maintenance screen, or spindle amplifier maintenance screen), pressing the soft key [(OPRT)] displays the following soft keys:



To enter data, place the machine in the MDI mode or the emergency stop state, position the cursor to a desired input item position, then enter desired data and press the soft key [INPUT].

(Alternatively, press the  key on the MDI unit.)

When the soft key [SETTING] is pressed after data has been entered, a warning message listed below is displayed if the entered data contains an error. When the data is valid, the corresponding FSSB-related parameters are set up. To restore the previous value normally set if, for example, an entered value is incorrect, press the soft key [CANCEL].

When this screen is first displayed after power-on, the previous values set normally are displayed.

## FSSB automatic setting warning messages

If an invalid setting is detected at FSSB automatic setting, a warning message listed below is displayed. EGB dummy axis setting means setting an even number for M/S on the axis setting screen for an axis for which bit 0 (SYN) of parameter No. 2011 is set to 1. EGB slave axis setting means setting an odd number for M/S on the axis setting screen for an axis for which bit 0 (SYN) of parameter No. 2011 is set to 1.

Warning message	Cause
Cs and M/S are set with the same axis	On the axis setting screen, a value is specified for Cs and M/S for an axis. Do not specify any value for Cs and M/S simultaneously.
Cs and M1-8 are set with the same axis	On the axis setting screen, a value is specified for Cs and M1-8 for an axis. Do not specify any value for Cs and M1-8 simultaneously.
Same number is set in AXIS	On the servo amplifier setting screen, an axis number is set more than once. Specify each axis number only once.
Same number is set in SP NUM	On the spindle amplifier setting screen, a spindle number is set more than once. Specify each spindle number only once.
Same number is set in CS	On the axis setting screen, a value is set for Cs more than once. Specify each value for Cs only once.
Same number is set in M/S	On the axis setting screen, a value is set for M/S more than once. Specify each value for M/S only once.
AXIS and Cs are set with the same axis	An axis number for which a value is set for Cs on the axis setting screen is set for AXIS on the servo amplifier setting screen. Do not set any axis number for which a value is set for Cs, on the servo amplifier setting screen.
Too many slaves (HRV4)	The maximum number (7) of slaves per FSSB line for servo HRV4 control is exceeded. Reduce the number of slaves connected to an FSSB line to 7 or less.
Too many slaves (HRV3)	The maximum number (15) of slaves per FSSB line for servo HRV3 control is exceeded. Reduce the number of slaves connected to an FSSB line to 15 or less.
Too many slaves (HRV2)	The maximum number (32) of slaves per FSSB line for servo HRV2 control is exceeded. Reduce the number of slaves connected to an FSSB line to 32 or less.
M/S is set with HRV4	For servo HRV4 control, a value is set for M/S. Do not set any value for M/S for servo HRV4 control.
AXIS is set with EGB dummy axis	An axis number set for EGB dummy axis setting is set for AXIS on the servo amplifier setting screen. Do not set any axis number for EGB dummy axis setting, on the servo amplifier screen.
M/S setting is illegal(EGB)	For M/S, the EGB slave axis setting corresponding to an EGB dummy axis setting is not made. Make the EGB slave axis setting.
AXIS is not set with EGB slave axis	An axis number for EGB slave axis setting is not set for AXIS on the servo amplifier setting screen. Set the axis number for EGB slave axis setting, on the servo amplifier setting screen.
AXIS is not set with M/S axis	An axis number set for M/S on the axis setting screen is not set for AXIS on the servo amplifier setting screen. Set the axis number for M/S, on the servo amplifier setting screen.
EGB dummy axis setting is illegal	EGB dummy axis setting is made when 32 slaves are connected to the second FSSB line. Decrease the number of slaves connected to the second FSSB line.
M/S setting is illegal	Invalid M/S setting. Correct the M/S setting.
Setting is illegal(servo)	Invalid servo axis setting (servo amplifier setting, axis setting). Correct the servo axis setting.
Setting is illegal(spindle)	Invalid spindle setting. Correct the spindle setting.

## 8.3 SERVO TUNING SCREEN

### 8.3.1 Parameter Setting



Set a parameter to display the servo tuning screen.

	#7	#6	#5	#4	#3	#2	#1	#0
3111								SVS

[Input type] Setting input  
 [Data type] Bit path

#0 SVS 0 : Servo tuning screen is not displayed.  
 1 : Servo tuning screen is displayed.

### 8.3.2 Displaying Servo Tuning Screen

- 1 Press function key  key, continuous menu key , and soft key [SV. PARA] in this order.
- 2 Press soft key [SV.TUN] to select the servo tuning screen.

SERVO MOTOR TUNING			
X AXIS			
	(PARAMETER)		(MONITOR)
(1)	FUNC. BIT	00001000	ALARM 1 00000000 (9)
(2)	LOOP GAIN	3000	ALARM 2 00000000 (10)
(3)	TUNING ST.	0	ALARM 3 00000000 (11)
(4)	SET PERIOD	0	ALARM 4 00000000 (12)
(5)	INT. GAIN	66	ALARM 5 00000000 (13)
(6)	PROP. GAIN	-594	LOOP GAIN 0 (14)
(7)	FILTER	0	POS ERRO 0 (15)
(8)	VELOC. GAIN	100	CURRENT (%) 0 (16)
			CURRENT(A) 0 (17)
			SPEED(RPM) 0 (18)

- (1) Function bit : Parameter No.2003
- (2) Loop gain : Parameter No.1825
- (3) Tuning start :
- (4) Set period :
- (5) Integral gain : Parameter No.2043
- (6) Proportional gain : Parameter No.2044
- (7) Filter : Parameter No.2067
- (8) Velocity gain : Set value  $\frac{(\text{Parameter No.2021})+256}{256} \times 100$
- (9) Alarm 1 : Diagnosis No.200
- (10) Alarm 2 : Diagnosis No.201
- (11) Alarm 3 : Diagnosis No.202
- (12) Alarm 4 : Diagnosis No.203
- (13) Alarm 5 : Diagnosis No.204
- (14) Loop gain : Actual loop gain

- (15) Position error : Actual position error (Diagnosis No.300)
- (16) Current(%) : Indicate current with % to the rated value.  
(when the bit 5 (SPF) of parameter No. 2014 is set to 0)  
Actual output(%) : Indicate output value with % to the motor rated value.  
(when the bit 5 (SPF) of parameter No. 2014 is set to 1)
- (17) Current(A) : Indicate current with A (peak value).  
(not indicated if bit 5 (SPF) of parameter No.2014 is set to 1)
- (18) Speed RPM : Number of motor actual rotation

	#7	#6	#5	#4	#3	#2	#1	#0
Alarm 1	OVL	LVA	OVC	HCA	HVA	DCA	FBA	OFA
Alarm 2	ALD			EXP				
Alarm 3		CSA	BLA	PHA	RCA	BZA	CKA	SPH
Alarm 4	DTE	CRC	STB	PRM				
Alarm 5		OFS	MCC	LDM	PMS	FAN	DAL	ABF

**NOTE**  
The empty fields do not represent alarm codes.

## 8.4 ADJUSTING REFERENCE POSITION (DOG METHOD)

### Overview

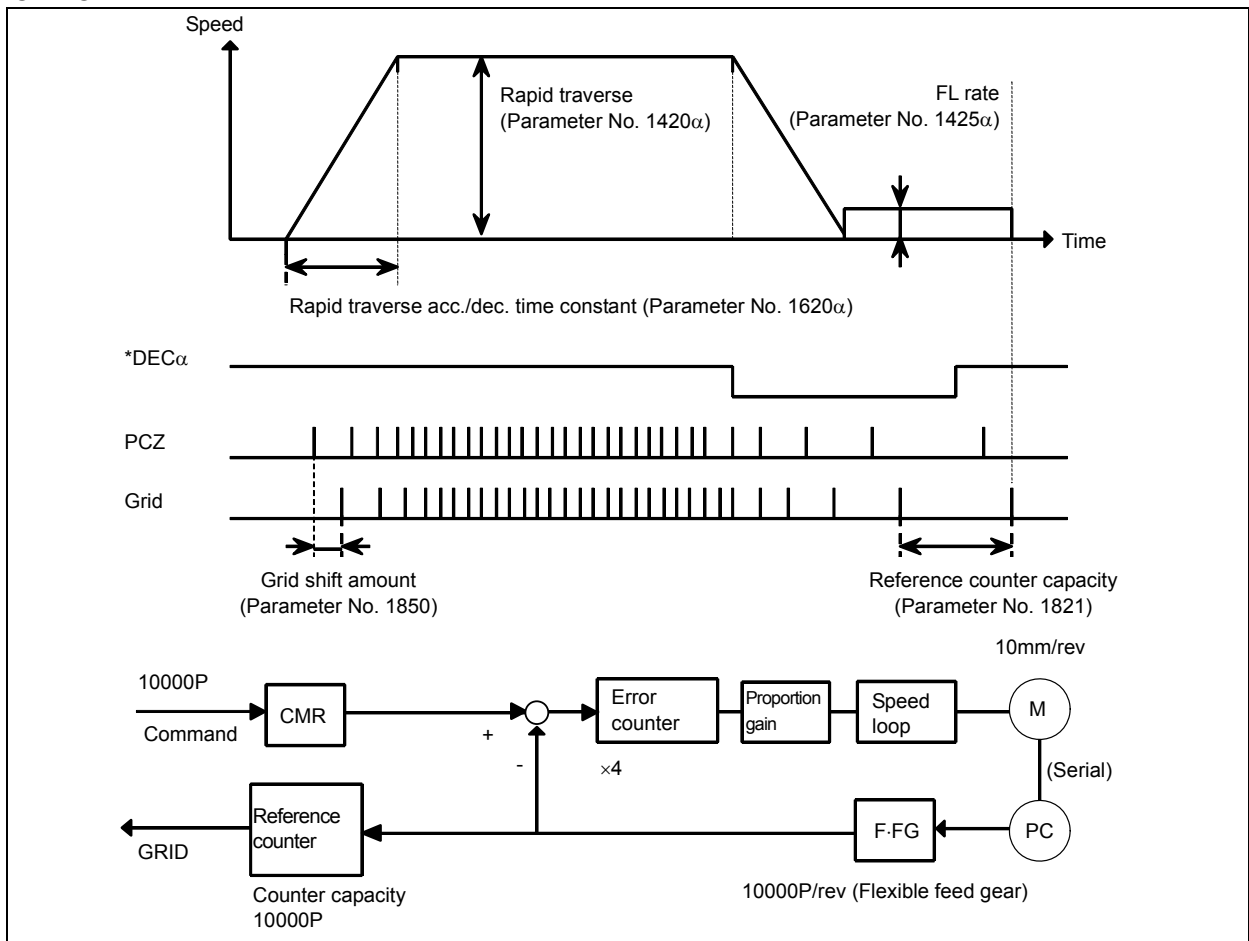



**Parameter**

There are the following related parameters.

	#7	#6	#5	#4	#3	#2	#1	#0
1005							DLZx	

[Input type] Parameter input  
 [Data type] Bit axis

**#1 DLZx** Function for setting the reference position without dogs  
 0: Disabled  
 1: Enabled

1821	Reference counter size for each axis
------	--------------------------------------

**NOTE**  
 When this parameter is set, the power must be turned off before operation is continued.

[Input type] Parameter input  
 [Data type] 2-word axis  
 [Unit of data] Detection unit  
 [Valid data range] 0 to 999999999  
 Set a reference counter size.  
 As a reference counter size, specify a grid interval for reference position return based on the grid method.  
 When a value less than 0 is set, the specification of 10000 is assumed.  
 When a linear scale with absolute address reference marks is used, set the interval of mark 1.

1850	Grid shift and reference position shift for each axis
------	---

**NOTE**  
 When this parameter is set, the power must be turned off before operation is continued.

[Input type] Parameter input  
 [Data type] 2-word axis  
 [Unit of data] Detection unit  
 [Valid data range] -99999999 to 99999999  
 To shift the reference position, the grid can be shifted by the amount set in this parameter. Up to the maximum value counted by the reference counter can be specified as the grid shift.  
 In case of bit 4 (SFDx) of parameter No. 1008 is 0: Grid shift  
 In case of bit 4 (SFDx) of parameter No. 1008 is 1: Reference point shift

**NOTE**  
 For setting the reference position without dogs, only the grid shift function can be used. (The reference position shift function cannot be used.)

	#7	#6	#5	#4	#3	#2	#1	#0
1815			APCx	APZx			OPTx	

[Input type] Parameter input  
 [Data type] Bit axis

**NOTE**  
 When at least one of these parameters is set, the power must be turned off before operation is continued.

- #1 **OPTx** Position detector
  - 0: A separate pulse coder is not used.
  - 1: A separate pulse coder is used.

**NOTE**  
 Set this parameter to 1 when using a linear scale with reference marks or a linear scale with an absolute address zero point (full-closed system).

- #4 **APZx** Machine position and position on absolute position detector when the absolute position detector is used
  - 0: Not corresponding
  - 1: Corresponding

When an absolute position detector is used, after primary adjustment is performed or after the absolute position detector is replaced, this parameter must be set to 0, power must be turned off and on, then manual reference position return must be performed. This completes the positional correspondence between the machine position and the position on the absolute position detector, and sets this parameter to 1 automatically.

- #5 **APCx** Position detector
  - 0: Other than absolute position detector
  - 1: Absolute position detector (absolute pulse coder)

**- Separate type Pulsecoder or linear scale is used**

1821	Reference counter capacity per axis	[P]
------	-------------------------------------	-----

Normally, the number of feedback pulses per motor revolution is set to the reference counter capacity.

\* When plural reference marks are on a linear scale, a quotient of the distance between the reference marks divided by an interfer may be used as a reference counter capacity:

(Example)

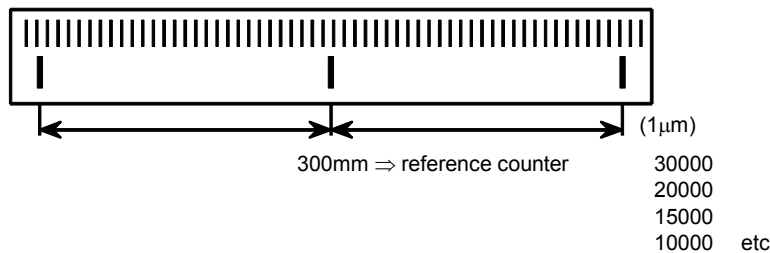

## 8.5 DOGGLESS REFERENCE POSITION SETTING

When there are no dog nor limit switch for reference position return, this function enables the tool to return the reference position that is set by MTB.

When the absolute position detector is used, the reference position once set remains also during power off. When the absolute detector is replaced or absolute position is lost, perform this setting.

### Overview

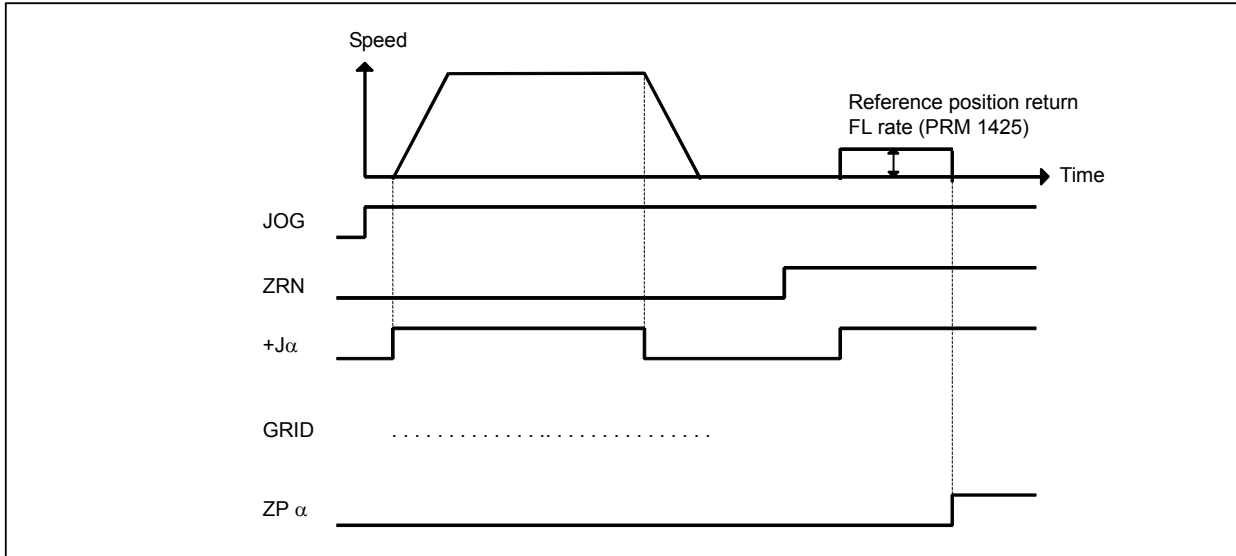

### Operation

- <1> Move the tool along an axis for setting the reference position in the reference position return direction in jog feed and position the tool near the reference position.
- <2> Select the manual reference position return mode and set the feed axis and direction select signal (+ or - direction) for the axis for setting the reference position to 1.
- <3> The tool is positioned at the nearest grid (electric grid based on the one-rotation signal of the position detector) in the reference position return direction specified in bit 5 (ZMIx) of parameter No. 1006 from the current position. This position is set as the reference position.
- <4> After the in-position status is confirmed, the reference position return completion signal (ZP1) and reference position establishment signal (ZRF1) are set to 1.

\* After the reference position has been set, select the reference position return mode (ZRN signal is 1) and turn on an axis-and-direction- select signal, then the tool returns to the reference position.

### Parameter

There are the following related parameters.

	#7	#6	#5	#4	#3	#2	#1	#0
1005							DLZx	

[Input type] Parameter input

[Data type] Bit axis

**#1 DLZx** Function for setting the reference position without dogs

0: Disabled

1: Enabled

	#7	#6	#5	#4	#3	#2	#1	#0
1006			ZMIx					

[Input type] Parameter input

[Data type] Bit axis

**NOTE**

When this parameter is set, the power must be turned off before operation is continued.

#5 **ZMIx** The direction of manual reference position return is:

0: + direction

1: - direction

## 8.6 $\alpha$ i SERVO WARNING INTERFACE

### Overview

The  $\alpha$ i servo system can report the warning status before one of the following target alarms occurs.

When the warning status is entered, a report to the PMC is issued.

For example, this signal can be used by the machine for retracting tools from the time a warning occurs by the time a servo alarm occurs.

### Signal

#### Servo warning detail signals SVWRN1 to 4 <F093.4 to 7>

[Classification] Output signal

[Function] Reports the warning signal corresponding to the state of the servo amplifier.

[Output condition] The following table shows the warning statuses of the servo amplifier and their corresponding warning signals.

Corresponding alarm messages	Warning status signals				Time from when a warning state signal is issued to until an alarm occurs
	SVWRN4 <F093.7>	SVWRN3 <F093.6>	SVWRN2 <F093.5>	SVWRN1 <F093.4>	
SV0444 SV INTERNAL FAN FAILURE	1	0	0	0	One minute
SV0601 SV EXTERNAL FAN FAILURE	1	0	0	1	Until overheat occurs (inconstant)
SV0443 PS INTERNAL FAN FAILURE	1	1	0	0	One minute
SV0606 PS EXTERNAL FAN FAILURE	1	1	0	1	Until overheat occurs (inconstant)
SV0431 PS OVERLOAD	1	1	1	0	One minute
SV0607 PS IMPROPER INPUT POWER	1	1	1	1	PSR: Five seconds, PS: One minute

A timing chart for handling a warning is shown below.

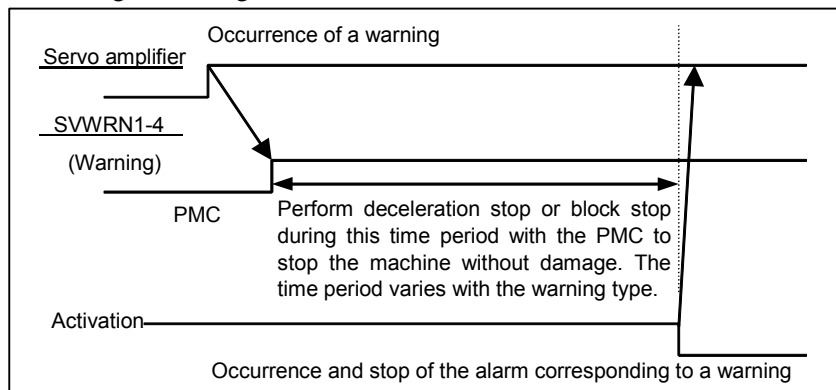

### Signal address

	#7	#6	#5	#4	#3	#2	#1	#0
F093	SVWRN4	SVWRN3	SVWRN2	SVWRN1				SVS

### Warning status alarms for $\alpha$ i servo amplifiers

When bit 2 (SWP) of parameter No. 1807 is set to 0, if an  $\alpha$ i servo amplifier is placed in the warning status, a DS alarm is output in addition to the servo warning detail signals.

If one of the following alarms is issued, automatic operation enters the feed hold state and movements along all controlled axes including PMC axes are decelerated to a stop. Issuing a warning status alarm does not cause the servo motor to be deactivated.

Alarm No. when the servo amplifier is in the warning status	Alarm No. when the servo amplifier is in the alarm status	Alarm message	Operation performed when the warning status occurs
DS0608	SV0444	SV INTERNAL FAN FAILURE	Immediately after the fan stops, DS0608 is displayed and movements along axes enter the feed hold stop state. The servo motor is kept active for 1 minute. After that, the servo motor is deactivated and SV0444 is displayed.
DS0609	SV0601	SV EXTERNAL FAN FAILURE	Immediately after the fan stops, DS0609 is displayed and movements along axes enter the feed hold stop state. When bit 2 of parameter No. 1807 is set to 1 after that, the alarm display can be canceled by a reset and operation can be restarted.
DS0610	SV0443	PS INTERNAL FAN FAILURE	Immediately after the fan stops, DS0610 is displayed and movements along axes enter the feed hold stop state. The servo motor is kept active for 1 minute. After that, the servo motor is deactivated and SV0443 is displayed.
DS0611	SV0606	PS EXTERNAL FAN FAILURE	Immediately after the fan stops, DS0611 is displayed and movements along axes enter the feed hold stop state. When bit 2 of parameter No. 1807 is set to 1 after that, the alarm display can be canceled by a reset and operation can be restarted.
DS0612	SV0431	PS OVERLOAD	If the main circuit of the common power supply (PS) is overloaded, DS0612 is displayed and movements along axes enter the feed hold stop state. A certain period of time after that, the servo motor is deactivated and SV0441 is displayed.

Alarm No. when the servo amplifier is in the warning status	Alarm No. when the servo amplifier is in the alarm status	Alarm message	Operation performed when the warning status occurs
DS0613	SV0607	PS IMPROPER INPUT POWER	If the main power source for the common power supply (PS) becomes abnormal, DS0613 is displayed and movements along axes enter the feed hold stop state.

After an alarm in the warning status listed above is issued, when the  $\alpha i$  servo amplifier is actually placed in the alarm status, the servo motor is deactivated and the number of an alarm in the alarm status is additionally displayed.

When bit 2 (SWP) of parameter No. 1807 is set to 1, if an  $\alpha i$  servo amplifier is placed in the warning status, only the servo warning detail signals are output and no alarm in the warning status (alarm DS0608 to DS0613) is issued. If a servo amplifier is placed in the warning status during automatic operation, automatic operation is kept. So, decelerate the movements along axes to a stop using the servo warning detail signals before the servo motor is deactivated. Note that if the movements along axes are not decelerated to a stop, the servo motor is suddenly deactivated during movement along axes.

## Parameter

	#7	#6	#5	#4	#3	#2	#1	#0
1807						SWP		

[Input type] Parameter input

[Data type] Bit path

**#2 SWP** This parameter specifies the operation of the  $\alpha i$  series servo amplifier in its warning state (for example, with the fan stopped).

0: An alarm is issued when the amplifier is placed in the warning state. Automatic operation enters the feed hold state and the servo axis is decelerated to a stop.

1: An alarm is not issued even when the amplifier is placed in the warning state. Automatic operation is kept. The servo is deactivated if the amplifier shifts from the warning state to the alarm state.

**⚠ CAUTION**

If operation is continued with the external fan stopped while bit 2 (SWP) of parameter No. 1807 is set to 1, the servo amplifier may be overheated and "overheat alarm", "IPM alarm", or "VRDY off alarm" may be issued depending on the operating conditions. If such an alarm is issued, the amplifier is deactivated and the servo motor is stopped by the dynamic brake, involving a risk of breaking the workpiece or tool as the stop from high-speed rotation requires an extended distance. The user should therefore understand that the operation with bit 2 (SWP) of parameter No. 1807 set to 1 is a temporary step to take before fan replacement. Once the fan has stopped, be sure to replace the fan immediately and set bit 2 (SWP) of parameter No. 1807 back to 0.

If bit 2 (SWP) of parameter No. 1807 is set to 1, the warning text "FAN" blinks on the NC screen to show that the external fan has been stopped. Also on the machine side, monitor the warning signal output to the PMC and remind the operator of the operation with the fan stopped.

## 8.7 $\alpha$ i SERVO INFORMATION SCREEN

### Overview

In the  $\alpha$ i servo system, ID information output from each of the connected units is obtained and output to the CNC screen.

The units that have ID information are shown below.

(Remark: Some instances of these units do not have ID information.)

- Servo motor
- Pulsecoder
- Servo amplifier
- Power supply

ID information is automatically read from each of the connected units during first startup of the CNC and then recorded. Next time (and the subsequent time) the CNC is started, the ID information that can be read is compared with one recorded at the first startup time in order to monitor any change to the connected units. (If there is a difference between them, the alarm mark (\*) appears.)

The recorded ID information can be edited. Therefore, the ID information of an unit that does not have ID information can be displayed. (However, the alarm mark (\*) indicating a difference between these IDs appears.)

### Parameter

	#7	#6	#5	#4	#3	#2	#1	#0
11320							IDC	

[Input type] Parameter input

[Data type] Bit path

- #1 **IDC** The soft key [UPDATEALL ID], which updates ID information on the servo or spindle information screen as a batch, is:  
 0: Not displayed.  
 1: Displayed.

**NOTE**  
 IDC is effective only if bit 0 (IDW) of parameter No. 13112 is set to 1.

	#7	#6	#5	#4	#3	#2	#1	#0
13112							SVI	IDW

[Input type] Parameter input  
 [Data type] Bit path

- #0 **IDW** Editing on the servo or spindle information screen is:  
 0: Prohibited.  
 1: Not prohibited.
- #1 **SVI** The servo information screen is:  
 0: Displayed.  
 1: Not displayed.

**Displaying the servo information screen**

- 1 Press the  function key, then press the [SYSTEM] soft key.
- 2 Press the [SERVO INFO] soft key to display the screen as shown below.

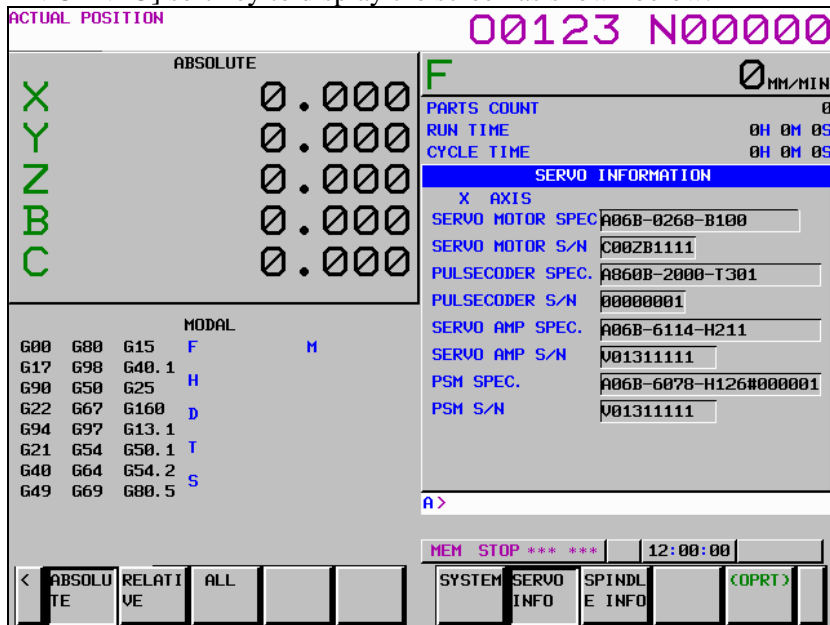

\* Servo information is stored in flash ROM. If there is a difference between the ID information in screen and the actual ID information, the corresponding items are preceded by \*, as shown below.



ACTUAL POSITION			00123 N00000			
ABSOLUTE			F <span style="float:right">MM/MIN</span>			
X	0.	0000	PARTS COUNT 0			
Y	0.	0000	RUN TIME 0H 0M 0S			
Z	0.	0000	CYCLE TIME 0H 0M 0S			
B	0.	0000	<b>SERVO INFORMATION</b>			
C	0.	0000	X AXIS			
MODAL			SERVO MOTOR SPEC. A06B-0260-B100			
G00 G80 G15	F	M	SERVO MOTOR S/N C00ZB1111			
G17 G98 G40.1			PULSECODER SPEC. A860B-2000-T301			
G90 G50 G25	H		PULSECODER S/N 00000001			
G22 G67 G160	D		*SERVO AMP SPEC. A06B-6114-H211			
G94 G97 G13.1			*SERVO AMP S/N U01311111			
G21 G54 G50.1	T		PSM SPEC. A06B-6070-H126#000001			
G40 G64 G54.2	S		PSM S/N U01311111			
G49 G69 G80.5			A >			
			MEM STOP *** ** 12:00:00			
< ABSOLUTE	RELATIVE	ALL	SYSTEM	SERVO INFO	SPINDLE INFO	<OPRT>

### Additional Information

Even if replacement is performed reasonably such as for repairing, this function incorrectly indicates the \* mark when it detects the replacement.

To clear the \* mark, follow the steps below to update the registered data, as described in the editing section later.



- (1) Make the registered data editable. (Bit 0 (IDW) of parameter No. 13112 = 1)
- (2) On the edit screen, place the cursor on the item from which you want to delete the \* mark.
- (3) Operate the soft keys [READ ID], [INPUT], and [SAVE] in that order.

To clear all \* marks at a time, press soft key [UPDATEALL ID] (displayed when bit 1 (IDC) of parameter No. 11320 is set to 1).

### Editing the servo information screen

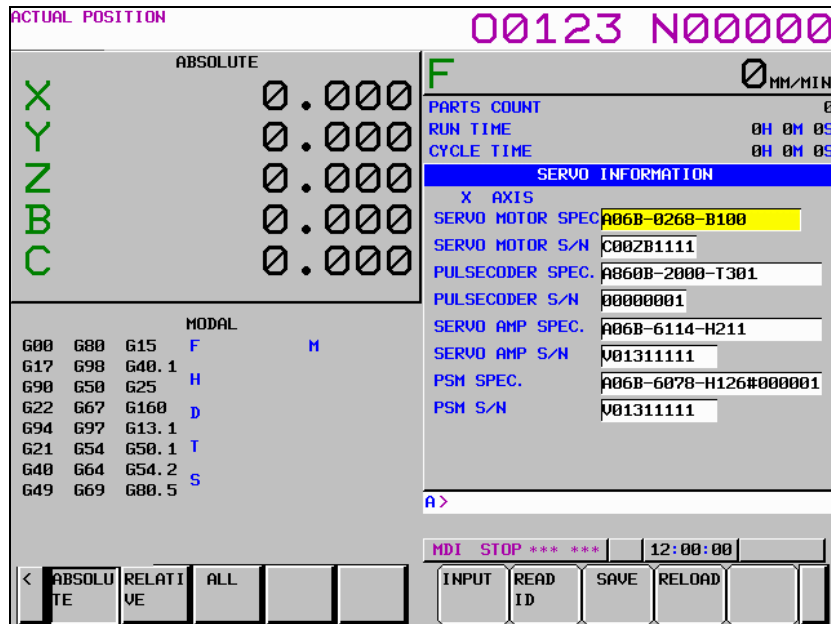
- 1 Assume that bit 0 (IDW) of parameter No. 13112 = 1 and bit 1 (IDC) of parameter No. 11320 = 1.
- 2 Press the MDI switch on the machine operator's panel.
- 3 Follow the steps shown in "Displaying the servo information screen" to display the screen as shown below.



- 4 To move the cursor on the screen, use the  and  keys.

## Screen operation

Mode	Key operation	Use
Viewing (*1)	Page key	Scrolls up or down on a screen-by-screen basis.
Editing (*2)	[INPUT]	Replace the selected ID information at the cursor position with the character string in key-in buffer.
	[CANCEL]	Deletes the character string in key-in buffer.
	[READ ID]	Transfers the ID information the connected device at the cursor has to the key-in buffer. Only the items preceded by * (*3) are valid.
	[SAVE]	Saves the ID information that has been changed on the servo information screen in flash ROM.
	[RELOAD]	Cancel the ID information that has been changed on the servo information screen and loads ID information from flash ROM.
	[UPDATEALL ID] (*1)	Updates the ID information for all axes that is output from each of the connected units displayed on the servo or spindle information screen at a time.
	Page key	Scrolls up or down on a screen-by-screen basis.
	Cursor key	Scrolls up or down the selection of ID information.

\*1 Viewing mode: when bit 0 (IDW) of parameter No. 13112 = 0

\*2 Editing mode: when bit 0 (IDW) of parameter No. 13112 = 1

\*3 If there is a difference between the ID information in screen and the actual ID information, the corresponding items are preceded by \*.

\*4 when bit 1 (IDC) of parameter No. 11320 = 1

ACTUAL POSITION		00123 N00000	
X Y Z B C	ABSOLUTE	0.0000	F
		0.0000	MM/MIN
		0.0000	PARTS COUNT 0
		0.0000	RUN TIME 0H 0M 0S
		0.0000	CYCLE TIME 0H 0M 0S
SERVO INFORMATION			
X AXIS			
		SERVO MOTOR SPEC.	A06B-0268-B100
		SERVO MOTOR S/N	C002B1111
		PULSECODER SPEC.	A060B-2000-T301
		PULSECODER S/N	00000001
		*SERVO AMP SPEC.	A06B-6114-H211
		*SERVO AMP S/N	V01311111
		PSM SPEC.	A06B-6078-H126#000001
		PSM S/N	V01311111
A >			
MODAL		12:00:00	
G00 G80 G15	F	MDI STOP *** **	
G17 G98 G40.1	M	INPUT	READ ID
G90 G50 G25	H	SAVE	RELOAD
G22 G67 G160	D		
G94 G97 G13.1			
G21 G54 G50.1	T		
G40 G64 G54.2	S		
G49 G69 G80.5			
< ABSOLUTE	RELATIVE		
TE	VE		
ALL			

**NOTE**

For axes that are not used by the  $\alpha i$  servo system, ID information of connected units cannot be obtained.

# 9 AC SPINDLE

---

This chapter outlines the serial interface spindle amplifiers and explains related parameters.

9.1	SERIAL INTERFACE AC SPINDLE .....	515
9.1.1	OUTLINE OF SPINDLE CONTROL .....	515
9.1.2	SPINDLE SETTING AND TUNING SCREEN .....	517
9.1.3	AUTOMATIC SETTING OF STANDARD PARAMETERS .....	524
9.1.4	WARNING INTERFACE .....	525
9.1.5	SPINDLE INFORMATION SCREEN .....	527

# 9.1 SERIAL INTERFACE AC SPINDLE

## 9.1.1 Outline of Spindle Control

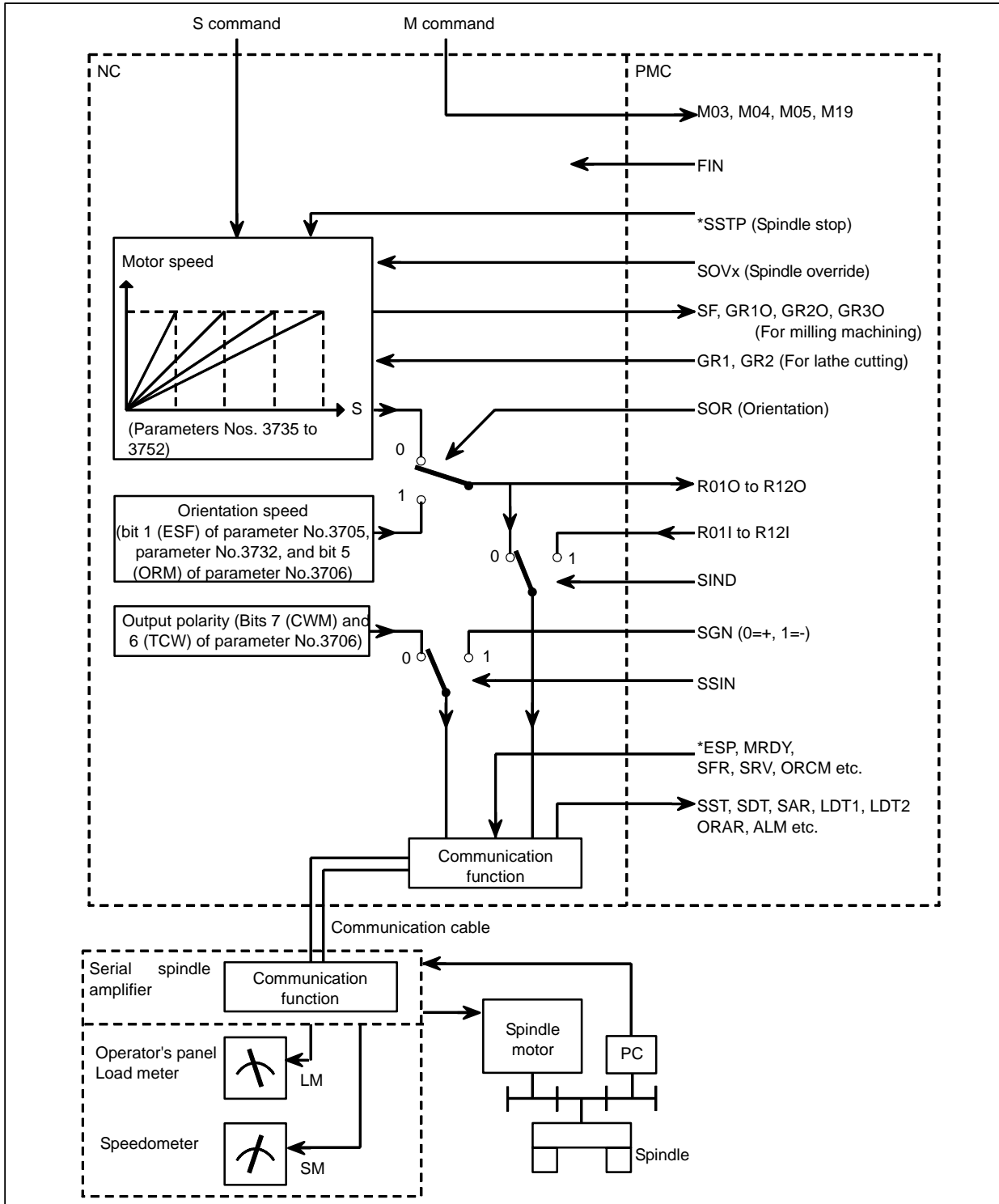

**9.1.1.1 Method A of gear change for machining center system  
(bit 2 (SGB) of Parameter No.3705 = 0)**

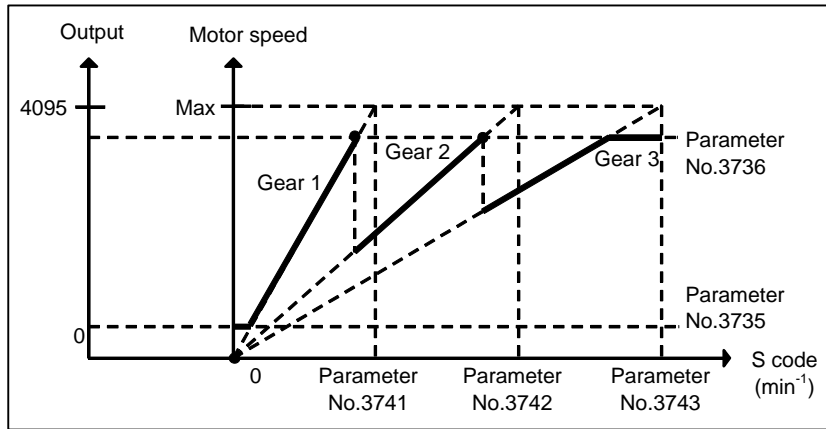

**9.1.1.2 Method B of gear change for machining center system  
(bit 2 (SGB) of Parameter No.3705 = 1)**

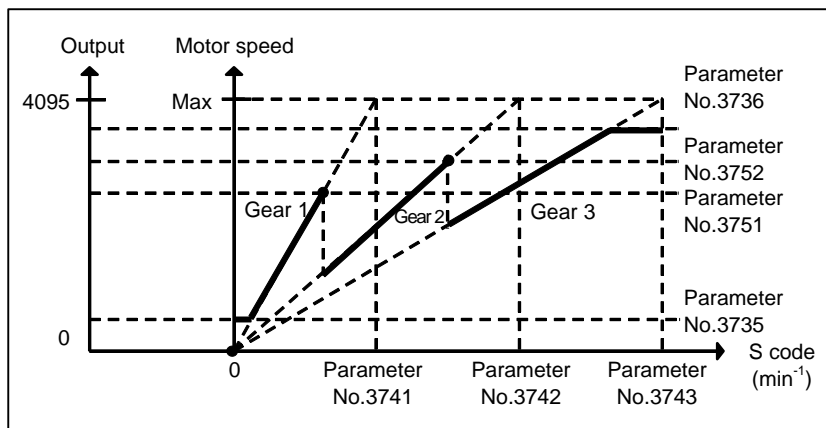

**9.1.1.3 Lathe system**

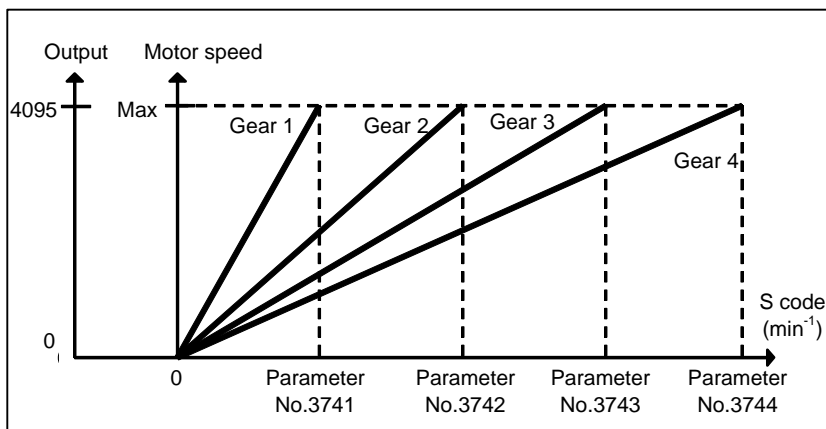

## 9.1.2 Spindle Setting and Tuning Screen

### 9.1.2.1 Display method





- (1) Confirm the parameters

	#7	#6	#5	#4	#3	#2	#1	#0
3111							SPS	

[Input type] Setting input

[Data type] Bit path

- #1 SPS 0: The spindle tuning screen is not displayed.  
 1: The spindle tuning screen is displayed.

- (2) Press the function key  to select the screen for setting parameters and other data.
- (3) Press the continuous menu key .
- (4) Press the soft key [SP.PRM]. Then, the spindle setting and tuning screen appears.
- (5) The following screens are provided. These screens can be selected using soft keys.  
 <1> [SP.SET] : Spindle setting screen  
 <2> [SP.TUN] : Spindle tuning screen  
 <3> [SP.MON] : Spindle monitor screen
- (6) With the page keys  , a spindle to be displayed can be selected (only when multiple serial spindles are connected).

### 9.1.2.2 Spindle setting screen

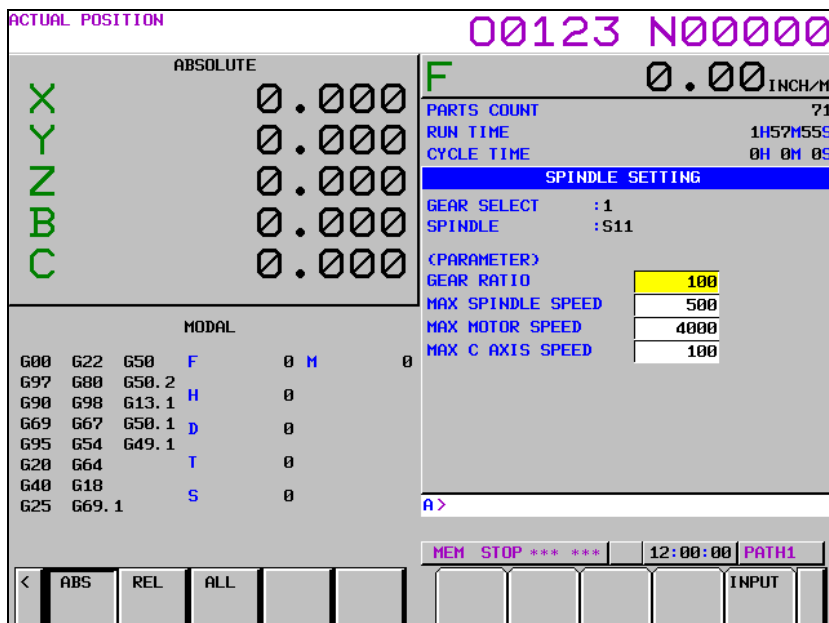

The screenshot displays the Spindle Setting screen with the following information:

- ACTUAL POSITION:** 00123 N00000
- ABSOLUTE POSITION:** X: 0.000, Y: 0.000, Z: 0.000, B: 0.000, C: 0.000
- MODAL SETTINGS:**
  - G00 G22 G50 F 0 M 0
  - G97 G80 G50.2
  - G90 G98 G13.1 H 0
  - G69 G67 G50.1 D 0
  - G95 G54 G49.1
  - G20 G64 T 0
  - G40 G18 S 0
  - G25 G69.1
- SPINDLE SETTING:**
  - GEAR SELECT : 1
  - SPINDLE : S11
  - GEAR RATIO: 100
  - MAX SPINDLE SPEED: 500
  - MAX MOTOR SPEED: 4000
  - MAX C AXIS SPEED: 100
- STATUS BAR:** MEM STOP \*\*\* \*\*\*, 12:00:00, PATH1
- KEYS:** <, ABS, REL, ALL, INPUT

### - Gear selection

The gear select status on the machine side is displayed.

Indication	CTH1	CTH2
1	0	0
2	0	1
3	1	0
4	1	1

### - Spindle

Select a spindle for which data is to be set.

- S11 : Main spindle amplifier for the 1st spindle
- S12 : Subspindle amplifier for the 1st spindle
- S21 : Main spindle amplifier for the 2nd spindle
- S22 : Subspindle amplifier for the 2nd spindle

Switching between the main spindle and the subspindle is performed by spindle switching control. Spindle switching control is the function for driving two spindle motors with one spindle amplifier. For details, refer to the following manual.

Refer to the section related to “Spindle Switching Control” in the FANUC AC SPINDLE MOTOR  $\alpha i / \beta i$  series, FANUC BUILT-IN SPINDLE MOTOR  $B i$  series PARAMETER MANUAL (B-65280EN).

### - Parameters

	S11: 1st Main	S12: 1st Sub	S21: 2nd Main	S22: 2nd Sub
Gear ratio (HIGH)	4056	4216	4056	4216
Gear ratio (MEDIUM HIGH)	4057		4057	
Gear ratio (MEDIUM LOW)	4058	4217	4058	4217
Gear ratio (LOW)	4059		4059	
Max. spindle speed (gear1)	3741		3741	
Max. spindle speed (gear2)	3742		3742	
Max. spindle speed (gear3)	3743		3743	
Max. spindle speed (gear4)	3744		3744	
Max. motor speed	4020	4196	4020	4196
Max. C axis speed	4021	None	4021	None



### 9.1.2.3 Spindle tuning screen

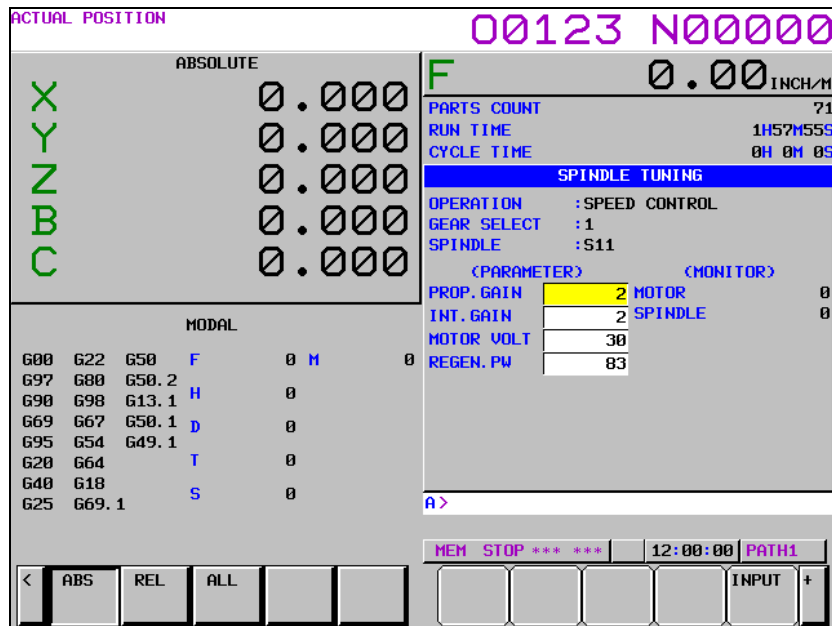

- **Operation mode**
  - 1 : SPEED CONTROL
  - 2 : SPINDLE ORIENTATION
  - 3 : SYNCHRONIZATION CONTROL
  - 4 : RIGID TAPPING
  - 5 : SP.CONTOURING CONTROL
  - 6 : SP.POSITIONING CONTROL

- **Gear selection**
- **Spindle**

The descriptions of these two items are the same as those for the spindle setting screen.

- **Displayed parameters**

The displayed parameters vary depending on the operation mode.

Spindle positioning control	Normal operation	Orientation	Synchronization control	Rigid tapping	Cs contour control
Proportional gain	Proportional gain	Proportional gain	Proportional gain	Proportional gain	Proportional gain
Integral gain	Integral gain	Integral gain	Integral gain	Integral gain	Integral gain
Loop gain	Motor voltage	Loop gain	Loop gain	Loop gain	Loop gain
Motor voltage	Regenerative power	Motor voltage	Motor voltage	Motor voltage	Motor voltage
ZRN gain (%)		ORAR gain (%)	Acceleration/	ZRN gain	ZRN gain (%)
Shift reference position		Shift spindle stop position	deceleration constant (%)	Shift reference position	Shift reference position
		Shift reference position	Shift reference position		

\*1) For the parameter numbers corresponding to the displayed parameter items, see Section “Correspondence between operation mode and parameters on spindle tuning screen”.

**- Displayed monitoring items**

The displayed monitoring items vary depending on the operation mode.

Spindle positioning control	Normal operation	Orientation	Synchronization control	Rigid tapping	Cs contour control
Motor speed	Motor speed	Motor speed	Motor speed	Motor speed	Motor speed
Feedrate	Spindle speed	Spindle speed	Spindle speed	Spindle speed	Spindle speed
Position deviation S		Position deviation S	Position deviation S1 Position deviation S2 Synchronous deviation	Position deviation S Position deviation Z Synchronous deviation	Position deviation S

\*1)

$$\text{Motor speed [min}^{-1}\text{]} = \frac{|\text{Spindle data}|}{16383} \times \text{Max. motor speed (*)}$$

(\*) Parameter No. 4020: Main spindle    Parameter No. 4196: Subspindle

**9.1.2.4 Spindle monitor screen**

The screenshot displays the Spindle Monitor screen with the following information:

- ACTUAL POSITION:** 00123 N00000
- ABSOLUTE POSITION:** X: 0.000, Y: 0.000, Z: 0.000, B: 0.000, C: 0.000
- MODAL SETTINGS:**
  - G00 G22 G50 F 0 M 0
  - G97 G80 G50.2 H 0
  - G90 G98 G13.1
  - G69 G67 G50.1 D 0
  - G95 G54 G49.1 T 0
  - G20 G64
  - G40 G18 S 0
  - G25 G69.1
- SPINDLE MONITOR:**
  - ALARM : OPERATION : SPEED CONTROL
  - SPINDLE SPEED : 0 RPM
  - MOTOR SPEED : 0 RPM
  - SPINDLE : S1
  - LOAD METER: 0% (Scale: 0, 50, 100, 150, 200%)
  - CONTROL INPUT : SFR MRDY \*ESP
  - CONTROL OUTPUT :
- STATUS BAR:** MEM STOP \*\*\* \*\*\*, 12:00:00, PATH1
- Navigation Buttons:** < ABS REL ALL SP. SET SP. TUN SP. MON

### - Spindle alarm

9001:MOTOR OVERHEAT	9053:ITP FAULT 2	9113:PS EXTERNAL FAN FAILURE
9002:EX DEVIATION SPEED	9054:OVERCURRENT	9120:COMMUNICATION DATA ERROR
9003:DC-LINK FUSE IS BROKEN	9055:ILLEGAL POWER LINE	9121:COMMUNICATION DATA ERROR
9004:PS IMPROPER INPUT POWER	9056:COOLING FAN FAILURE	9122:COMMUNICATION DATA ERROR
9006:THERMAL SENSOR DISCONNECT	9057:PS EXCESS-REGENERATION2	9123:SPINDLE SWITCH CIRCUIT ERROR
9007:OVER SPEED	9058:PS OVERLOAD	9124:LEARNING CTRL ROTATION CMD ERROR
9009:OVERHEAT MAIN CIRCUIT	9059:PS INTERNAL FAN FAILURE	9125:LEARNING CTRL COMP ORDER ERROR
9011:PS OVER VOLT. DC LINK	9061:SEMI-FULL ERROR EXCESS	9127:LEARNING CTRL PERIOD ERROR
9012:OVERCURRENT POWER CIRCUIT	9065:SERIAL SPINDLE ALARM	9128:SP SYNC VELOCITY ERROR EXCESS
9013:CPU DATA MEMORY FAULT	9066:COM. ERROR BETWEEN SP AMPS	9129:SP SYNC POSITION ERROR EXCESS
9014:SOFTWARE SERIES MISMATCH	9067:FSC/EGB COMMAND ERROR	9130:TORQUE TANDEM POLARITY ERROR
9015:SPINDLE SWITCHING FAULT	9069:SAFETY SPEED OVER	9131:SPINDLE TUNING FUNCTION ALARM
9016:RAM ERROR	9070:ILLEGAL AXIS DATA	9132:SER.SENSOR DATA ERROR
9017:ID NUMBER PARITY ERROR	9071:SAFETY PARAMETER ERROR	9133:SER.SENSOR TRANSFER ERROR
9018:SUMCHECK ERROR PROGRAM ROM	9072:MISMATCH RESULT OF MOTOR SPEED CHECK	9134:SER.SENSOR SOFT PHASE ERROR
9019:EXCESS OFFSET CURRENT U	9073:MOTOR SENSOR DISCONNECTED	9135:SAFETY SPEED ZERO ERROR(SP)
9020:EXCESS OFFSET CURRENT V	9074:CPU TEST ERROR	9136:MISMATCH RESULT OF SAFETY SPEED ZERO CHECK(SP)
9021:POS SENSOR POLARITY ERROR	9075:CRC ERROR	9137:SP DEVICE COMMUNICATION ERROR
9022:SP AMP OVER CURRENT	9076:INEXECUTION OF SAFETY FUNCTIONS	9139:SER.SENSOR PULSE MISS
9024:SERIAL TRANSFER ERROR	9077:MISMATCH RESULT OF AXIS NUMBER CHECK	9140:SER.SENSOR COUNT MISS
9027:DISCONNECT POSITION CODER	9078:MISMATCH RESULT OF SAFETY PARAMETER CHECK	9141:SER.SENSOR NO 1-ROT SIGNAL
9029:OVERLOAD	9079:INITIAL TEST ERROR	9142:SER.SENSOR ABNORMAL
9030:OVERCURRENT	9080:ALARM AT THE OTHER SP AMP.	9143:CS HIGH SPEED CHANGE CMD ERROR
9031:MOTOR LOCK	9081:1-ROT MOTOR SENSOR ERROR	9144:CURRENT DETECT CIRCUIT ERROR
9032:SIC-LSI RAM FAULT	9082:NO 1-ROT MOTOR SENSOR	9145:LOW VOLTAGE DRIVER
9033:PS PRE-CHARGE FAILURE	9083:MOTOR SENSOR SIGNAL ERROR	9146:SP:INTERNAL OVERHEAT
9034:ILLEGAL PARAMETER	9084:SPNDL SENSOR DISCONNECTED	9147:SP:GROUND FAULT
9036:OVERFLOW ERROR COUNTER	9085:1-ROT SPNDL SENSOR ERROR	9200:PS GROUND FAULT
9037:ILLEGAL SETTING VELOCITY DETECTOR	9086:NO 1-ROT SPNDL SENSOR	9201:PS OVERCURRENT 2
9041:ILLEGAL 1REV SIGN OF POSITION CODER	9087:SPNDL SENSOR SIGNAL ERROR	9202:PS OVERCURRENT 3
9042:NO 1REV SIGN OF POSITION CODER	9088:COOLING RADI FAN FAILURE	9203:PS OVERCURRENT 4
9043:DISCONNECT POSITION CODER DEF. SPEED	9089:SUB MODULE SM (SSM) ERROR	9204:PS SOFT THERMAL
9046:ILLEGAL 1REV SIGN OF SCREW CUT	9090:UNEXPECTED ROTATION	9205:PS OVER VOLT. DC LINK 2
9047:ILLEGAL SIGNAL OF POSITION CODER	9091:POLE POSITION COUNT MISS	9206:PS OVER VOLT. DC LINK 3
9049:DEF. SPEED IS OVER VALUE	9092:OVER SPEED TO VELOCITY COMMAND	9207:PS OVER VOLT. DC LINK 4
9050:SYNCHRONOUS VALUE IS OVER SPEED	9110:AMP COMMUNICATION ERROR	
9051:PS LOW VOLT. DC LINK	9111:PS LOW VOLT. CONTROL	
9052:ITP FAULT 1	9112:PS EXCESS-REGENERATION1	

### - Operation

Following 6 modes are available:

- a. Normal operation
- b. Orientation
- c. Synchronous operation
- d. Rigid tapping
- e. Cs contour control
- f. Spindle positioning control

**- Load meter**

The load meter displays spindle load in a unit of 10%.

$$\text{Load meter [\%]} = \frac{\text{Load meter data}}{32767} \times \text{Max. output value of load meter (*)}$$

- (\*) Parameter No. 4127: High-speed winding of main spindle
- Parameter No. 4274: High-speed winding of subspindle
- Parameter No. 4093: Low-speed winding of main spindle
- Parameter No. 4279: Low-speed winding of subspindle

**- Control input signal**

Max.10 signals those are ON are displayed from the following signals:

TLML	Torque limit command (low)	SPSL	Spindle selection signal
TLMH	Torque limit command (high)	MCFN	Power line switching
CTH1	Gear signal 1	SOCN	Soft start/stop
CTH2	Gear signal 2	RSL	Output switching request
SRV	Spindle reverse rotation	RCH	Power line state confirm
SFR	Spindle forward rotation	INDX	Orientation stop pos. change
ORCM	Spindle orientation	ROTA	Rotation direction of ORCM
MRDY	Machine ready	NRRO	Short-cut of ORCM
ARST	Alarm reset signal	INTG	Speed integral control signal
*ESP	Emergency stop	DEFM	Differential mode command

**- Control output signals**

Max. 10 signals those are ON are displayed from the following signals:

ALM	Alarm signal	TLM5	Torque limitation
SST	Speed zero signal	ORAR	Orientation end signal
SDT	Speed detecting signal	CHP	Power line switched signal
SAR	Speed arrival signal	CFIN	Spindle switch complete
LDT1	Load detecting signal 1	RCHP	Output switch signal
LDT2	Load detecting signal 2	RFCN	Output switch complete signal

**9.1.2.5 Correspondence between operation mode and parameters on spindle tuning screen**

**- Normal operation mode**

	S11: 1st Main	S12: 1st Sub	S21: 2nd Main	S22: 2nd Sub
Proportional gain (HIGH)	4040	4206	4040	4206
Proportional gain (LOW)	4041	4207	4041	4207
Integral gain (HIGH)	4048	4212	4048	4212
Integral gain (LOW)	4049		4049	
Motor voltage	4083	4236	4083	4236
Regenerative power	4080	4231	4080	4231

**- Orientation mode**

	S11: 1st Main	S12: 1st Sub	S21: 2nd Main	S22: 2nd Sub
Proportional gain (HIGH)	4042	4208	4042	4208
Proportional gain (LOW)	4043	4209	4043	4209
Integral gain (HIGH)	4050	4213	4050	4213
Integral gain (LOW)	4051		4051	
Loop gain (HIGH)	4060	4218	4060	4218
Loop gain (MED.HIGH)	4061		4061	

	<b>S11: 1st Main</b>	<b>S12: 1st Sub</b>	<b>S21: 2nd Main</b>	<b>S22: 2nd Sub</b>
Loop gain (MED.LOW)	4062	4219	4062	4219
Loop gain (LOW)	4063		4063	
Motor voltage	4084	4237	4084	4237
Gain change upon completion of orientation	4064	4220	4064	4220
Stop position shift	4077	4228	4077	4228
PC-type orientation stop position	4031	4204	4031	4204

### - Synchronization control mode

	<b>S11: 1st Main</b>	<b>S12: 1st Sub</b>	<b>S21: 2nd Main</b>	<b>S22: 2nd Sub</b>
Proportional gain (HIGH)	4044	4210	4044	4210
Proportional gain (LOW)	4045	4211	4045	4211
Integral gain (HIGH)	4052	4214	4052	4214
Integral gain (LOW)	4053		4053	
Loop gain (HIGH)	4065	4221	4065	4221
Loop gain (MED.HIGH)	4066		4066	
Loop gain (MED.LOW)	4067	4222	4067	4222
Loop gain (LOW)	4068		4068	
Motor voltage	4085	4238	4085	4238
Acc./Dec. time constant	4032		4032	
Shift amount	4034		4034	

### - Rigid tapping mode

	<b>S11: 1st Main</b>	<b>S12: 1st Sub</b>	<b>S21: 2nd Main</b>	<b>S22: 2nd Sub</b>
Proportional gain (HIGH)	4044	4210	4044	4210
Proportional gain (LOW)	4045	4211	4045	4211
Integral gain (HIGH)	4052	4214	4052	4214
Integral gain (LOW)	4053		4053	
Loop gain (HIGH)	4065	4221	4065	4221
Loop gain (MED.HIGH)	4066		4066	
Loop gain (MED.LOW)	4067	4222	4067	4222
Loop gain (LOW)	4068		4068	
Motor voltage	4085	4238	4085	4238
ZRN gain %	4091	4239	4091	4239
Grid shift amount at servo mode	4073	4223	4073	4223

### - Cs contour control mode

	<b>S11: 1st Main</b>	<b>S12: 1st Sub</b>	<b>S21: 2nd Main</b>	<b>S22: 2nd Sub</b>
Proportional gain (HIGH)	4046		4046	
Proportional gain (LOW)	4047		4047	
Integral gain (HIGH)	4054		4054	
Integral gain (LOW)	4055		4055	
Loop gain (HIGH)	4069		4069	
Loop gain (MED.HIGH)	4070		4070	
Loop gain (MED.LOW)	4071		4071	
Loop gain (LOW)	4072		4072	
Motor voltage	4086		4086	
ZRN gain %	4092		4092	
Reference position shift	4135		4135	

### - Spindle positioning control mode

	S11: 1st Main	S12: 1st Sub	S21: 2nd Main	S22: 2nd Sub
Proportional gain (HIGH)	4044	4210	4044	4210
Proportional gain (LOW)	4045	4211	4045	4211
Integral gain (HIGH)	4052	4214	4052	4214
Integral gain (LOW)	4053		4053	
Loop gain (HIGH)	4065	4221	4065	4221
Loop gain (MED.HIG)	4066		4066	
Loop gain (MED.LOW)	4067	4222	4067	4222
Loop gain (LOW)	4068		4068	
Motor voltage	4085	4238	4085	4238
ZRN gain %	4091	4239	4091	4239
Reference position shift	4073	4223	4073	4223

## 9.1.3 Automatic Setting of Standard Parameters

The standard parameters related to each motor model can be set automatically.

\* The specifications for controlling a motor depend on the specifications defined by the machine tool builder. The parameters defined by the machine tool builder are set as the standard values (initial values) by this automatic setting function. Therefore, when performing automatic operation, always set parameters properly according to the parameter list (parameters 4000 and later).

- 1 Turn on the power in the emergency stop state.
- 2 Set bit 7 of parameter 4019 to 1.

	#7	#6	#5	#4	#3	#2	#1	#0
4019	LDSP							

[Input type] Parameter input

[Data type] Bit spindle

**#7 LDSP** The parameters for the serial interface spindle are:

- 0: Not set automatically.
- 1: Set automatically.

- 3 Set a motor model code.

4133	Motor model code

Code	Motor model	Amplifier
301	$\alpha i$ 0.5/10000 (3000/10000min <sup>-1</sup> )	$\alpha i$ SP2.2
302	$\alpha i$ 1/10000 (3000/10000min <sup>-1</sup> )	$\alpha i$ SP2.2
304	$\alpha i$ 1.5/10000 (1500/10000min <sup>-1</sup> )	$\alpha i$ SP5.5
305	$\alpha i$ 1.5/15000 (3000/15000min <sup>-1</sup> )	$\alpha i$ SP15
306	$\alpha i$ 2/10000 (1500/10000min <sup>-1</sup> )	$\alpha i$ SP5.5
307	$\alpha i$ 2/15000 (3000/15000min <sup>-1</sup> )	$\alpha i$ SP22
308	$\alpha i$ 3/10000 (1500/10000min <sup>-1</sup> )	$\alpha i$ SP5.5
309	$\alpha i$ 3/12000 (1500/12000min <sup>-1</sup> )	$\alpha i$ SP11
310	$\alpha i$ 6/10000 (1500/10000min <sup>-1</sup> )	$\alpha i$ SP11
311	$\alpha i$ 0.5/10000HV (3000/10000min <sup>-1</sup> )	$\alpha i$ SP5.5HV
312	$\alpha i$ 8/8000 (1500/8000min <sup>-1</sup> )	$\alpha i$ SP11
313	$\alpha i$ 1/10000HV (3000/10000min <sup>-1</sup> )	$\alpha i$ SP5.5HV
314	$\alpha i$ 12/7000 (1500/7000min <sup>-1</sup> )	$\alpha i$ SP15

Code	Motor model	Amplifier
315	$\alpha i I$ 1.5/10000HV (1500/10000min <sup>-1</sup> )	$\alpha i$ SP5.5HV
316	$\alpha i I$ 15/7000 (1500/7000min <sup>-1</sup> )	$\alpha i$ SP22
317	$\alpha i I$ 2/10000HV (1500/10000min <sup>-1</sup> )	$\alpha i$ SP5.5HV
318	$\alpha i I$ 18/7000 (1500/7000min <sup>-1</sup> )	$\alpha i$ SP22
319	$\alpha i I$ 3/10000HV (1500/10000min <sup>-1</sup> )	$\alpha i$ SP5.5HV
320	$\alpha i I$ 22/7000 (1500/7000min <sup>-1</sup> )	$\alpha i$ SP26
321	$\alpha i I$ 6/10000HV (1500/10000min <sup>-1</sup> )	$\alpha i$ SP11HV
322	$\alpha i I$ 30/6000 (1150/6000min <sup>-1</sup> )	$\alpha i$ SP45
323	$\alpha i I$ 40/6000 (1500/6000min <sup>-1</sup> )	$\alpha i$ SP45
324	$\alpha i I$ 50/4500 (1150/4500min <sup>-1</sup> )	$\alpha i$ SP55
325	$\alpha i I$ 8/8000HV (1500/8000min <sup>-1</sup> )	$\alpha i$ SP11HV
326	$\alpha i I$ 12/7000HV (1500/7000min <sup>-1</sup> )	$\alpha i$ SP15HV
327	$\alpha i I$ 15/7000HV (1500/7000min <sup>-1</sup> )	$\alpha i$ SP30HV
328	$\alpha i I$ 22/7000HV (1500/7000min <sup>-1</sup> )	$\alpha i$ SP30HV
329	$\alpha i I$ 30/6000HV (1150/6000min <sup>-1</sup> )	$\alpha i$ SP45HV
401	$\alpha i I$ 6/12000 (1500/12000, 4000/12000min <sup>-1</sup> )	$\alpha i$ SP11
402	$\alpha i I$ 8/10000 (1500/10000, 4000/10000min <sup>-1</sup> )	$\alpha i$ SP11
403	$\alpha i I$ 12/10000 (1500/10000, 4000/10000min <sup>-1</sup> )	$\alpha i$ SP15
404	$\alpha i I$ 15/10000 (1500/10000, 4000/10000min <sup>-1</sup> )	$\alpha i$ SP22
405	$\alpha i I$ 18/10000 (1500/10000, 4000/10000min <sup>-1</sup> )	$\alpha i$ SP22
406	$\alpha i I$ 22/10000 (1500/10000, 4000/10000min <sup>-1</sup> )	$\alpha i$ SP26
407	$\alpha i I P$ 12/6000 (500/1500, 750/6000min <sup>-1</sup> )	$\alpha i$ SP11
408	$\alpha i I P$ 15/6000 (500/1500, 750/6000min <sup>-1</sup> )	$\alpha i$ SP15
409	$\alpha i I P$ 18/6000 (500/1500, 750/6000min <sup>-1</sup> )	$\alpha i$ SP15
410	$\alpha i I P$ 22/6000 (500/1500, 750/6000min <sup>-1</sup> )	$\alpha i$ SP22
411	$\alpha i I P$ 30/6000 (400/1500, 575/6000min <sup>-1</sup> )	$\alpha i$ SP22
412	$\alpha i I P$ 40/6000 (400/1500, 575/6000min <sup>-1</sup> )	$\alpha i$ SP26
413	$\alpha i I P$ 50/6000 (575/1500, 1200/6000min <sup>-1</sup> )	$\alpha i$ SP26
414	$\alpha i I P$ 60/4500 (400/1500, 750/4500min <sup>-1</sup> )	$\alpha i$ SP30
415	$\alpha i I$ 100/4000HV (1000/3000, 2000/4000min <sup>-1</sup> )	$\alpha i$ SP75HV
418	$\alpha i I P$ 40/6000HV (400/1500, 575/6000min <sup>-1</sup> )	$\alpha i$ SP30HV

- 4 Turn off the power then back on. Then, the parameters are read.

## 9.1.4 Warning Interface

### Overview

The warning state can be reported before an alarm is issued. When the warning state is entered, a report to the PMC is sent.

For example, this signal can be used for retracting tools or reducing cutting load from the time a warning occurs by the time an overheat alarm occurs. In addition, the warning number is displayed also on the diagnosis screen.

### Signal

#### Spindle warning detailed signals SPWRN1 to SPWRN9 <F264.0 to .7, F265.0>

[Classification] Output

[Function] Reports the warning number corresponding to the state of the  $\alpha i$  spindle amplifier.

[Output condition] When the  $\alpha i$  spindle is in the warning state, a warning number consisting of SPWRN1 to SPWRN9 is output as nine-bit binary data.

If warnings occurred on multiple  $\alpha i$  spindle amplifiers, the warning number of the  $\alpha i$  spindle having the smallest axis number is output.

The warning numbers and their descriptions are shown below.

Warning number	Contents	Details
01	MOTOR OVERHEAT	When the motor temperature increases beyond the overheat warning detection level (set by a parameter), a warning signal is output. At this time, spindle operation is continued. So, perform necessary processing with the PMC. An alarm is issued when the motor temperature has reached the overheat alarm detection level.
04	PS IMPROPER INPUT POWER	If an abnormal condition is detected on the main power supply, a warning signal is output. Since the spindle continues to operate at this time, use the PMC to perform processing as needed.
56	COOLING FAN FAILURE	If the internal fan stops, the warning signal is output. Since the spindle continues to operate at this time, use the PMC to perform processing as needed. About one minute after the warning signal is output, an alarm occurs.
58	PS OVERLOAD	If the main circuit of the Power Supply (PS) is overloaded, the warning signal is output. Since the spindle continues to operate at this time, use the PMC to perform processing as needed. An alarm is issued when a certain period of time elapses after warning signal output.
59	PS INTERNAL FAN FAILURE	If the Power Supply (PS) cooling fan stops, the warning signal is output. Since the spindle continues to operate at this time, use the PMC to perform processing as needed. About one minute after the warning signal is output, an alarm occurs.
88	COOLING RADI FAN FAILURE	If the radiator cooling fan stops, the warning signal is output. Since the spindle continues to operate at this time, use the PMC to perform processing as needed. If the main circuit overheats, an alarm occurs.
113	PS EXTERNAL FAN FAILURE	If the Power Supply (PS) radiator cooling fan stops, the warning signal is output. Since the spindle continues to operate at this time, use the PMC to perform processing as needed. If the Power Supply (PS) main circuit overheats, an alarm occurs.

**Signal address**

	#7	#6	#5	#4	#3	#2	#1	#0
F264	SPWRN8	SPWRN7	SPWRN6	SPWRN5	SPWRN4	SPWRN3	SPWRN2	SPWRN1
F265								SPWRN9

**Diagnosis screen**

The status of a warning is displayed on the following diagnostic screen.

712	Warning status of spindle
-----	---------------------------

[Data type] Word spindle

The number of a warning caused on each spindle is indicated.

If there is no warning, 0 is indicated.



## 9.1.5 Spindle Information Screen

### Overview

In the  $\alpha$ i spindle system, ID information output from each of the connected units is obtained and output to the CNC screen.

The units that have ID information are shown below.

- Spindle amplifier (SP)
- Power Supply (PS)

The ID information recorded during first startup can be compared with the ID information read this time on the screen to check whether the configuration of the connected units is changed. (If there is a difference between them, the alarm mark (\*) appears.)

The recorded ID information can be edited. Therefore, the ID information of an unit that does not have ID information can be displayed. (However, the alarm mark (\*) indicating a difference between these IDs appears.)

### Parameter

	#7	#6	#5	#4	#3	#2	#1	#0
11320							IDC	

[Input type] Parameter input

[Data type] Bit path

**#1 IDC** The soft key [UPDATEALL ID], which updates ID information on the servo or spindle information screen as a batch, is:

0: Not displayed.

1: Displayed.

#### NOTE

IDC is effective only if bit 0 (IDW) of parameter No. 13112 is set to 1.

	#7	#6	#5	#4	#3	#2	#1	#0
13112						SPI		IDW

[Input type] Parameter input

[Data type] Bit path

**#0 IDW** Editing on the servo or spindle information screen is:

0: Prohibited.

1: Not prohibited.

**#2 SPI** The servo information screen is:

0: Displayed.

1: Not displayed.

Displaying the spindle information screen

- 1 Press the  function key, then press the [SYSTEM] soft key.
- 2 Press the [SPINDLE INFO] soft key to display the screen as shown below.

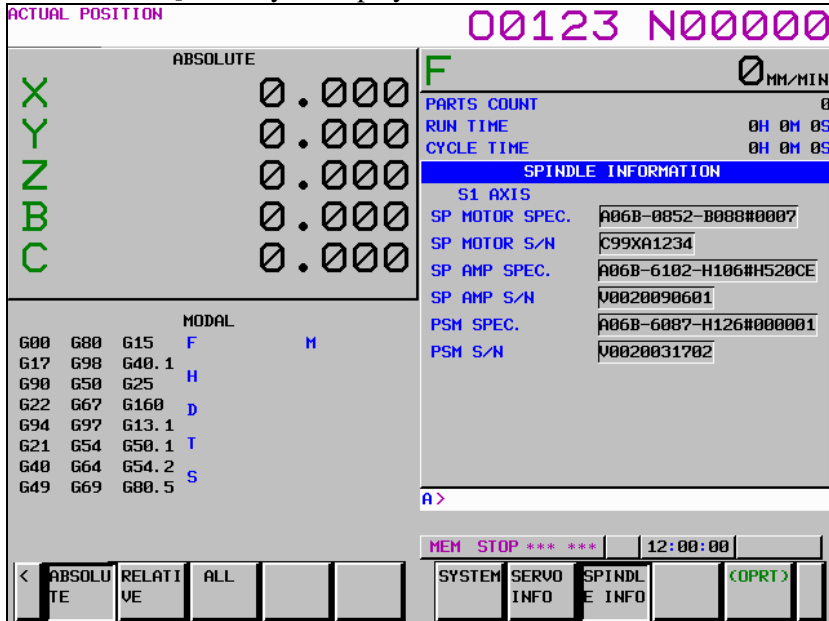

\* Spindle information is stored in flash ROM. If there is a difference between the ID information in screen and the actual ID information, the corresponding items are preceded by \*, as shown below.

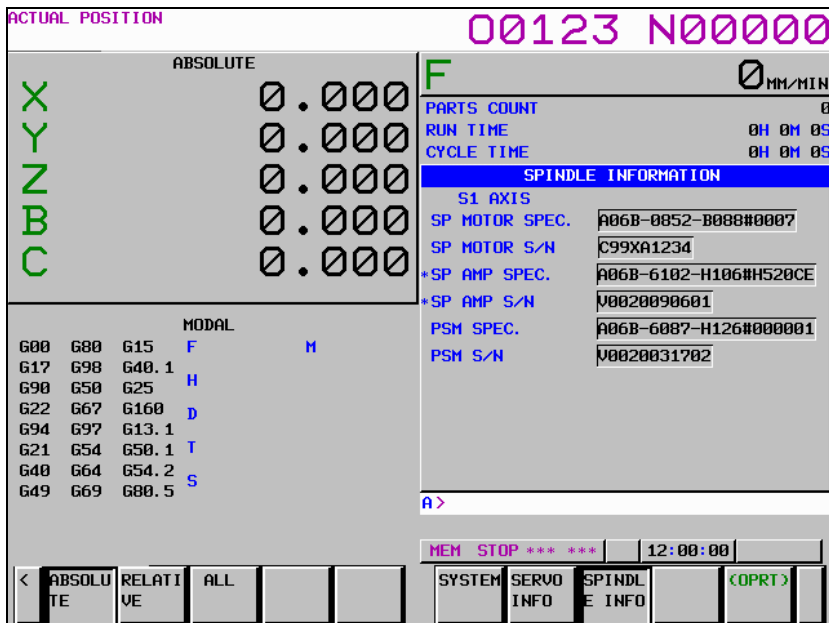

### - Spindle switch control

When spindle switch control is used, the ID information of the subspindle is also displayed.

ACTUAL POSITION			00123 N00000	
ABSOLUTE			F	0 MM/MIN
X		0.0000	PARTS COUNT	0
Y		0.0000	RUN TIME	0H 0M 0S
Z		0.0000	CYCLE TIME	0H 0M 0S
B		0.0000	<b>SPINDLE INFORMATION</b>	
C		0.0000	S1 AXIS	
MODAL			SP MOTOR SPEC.	A06B-0852-B088#0007
G00 G80 G15	F	M	SP MOTOR S/N	C99XA1234
G17 G98 G40.1	H		SUBSP MOTOR SPEC.	A06B-0852-B088#0007
G90 G50 G25	D		SUBSP MOTOR S/N	C99XA1235
G22 G67 G160	T		SP AMP SPEC.	A06B-6102-H106#H520CE
G94 G97 G13.1	S		SP AMP S/N	U0020090601
G21 G54 G50.1			PSM SPEC.	A06B-6087-H126#000001
G40 G64 G54.2			PSM S/N	U0020031702
G49 G69 G80.5			A >	
			MEM STOP *** **	12:00:00
< ABSOLUTE	RELATIVE	ALL	SYSTEM INFO	SERVO INFO
TE	VE		SPINDLE INFO	(OPRT)

#### Additional Information

Even if replacement is performed reasonably such as for repairing, this function incorrectly indicates the \* mark when it detects the replacement.

To clear the \* mark, follow the steps below to update the registered data, as described in the editing section later.



- (1) Make the registered data editable. (Bit 0 (IDW) of parameter No. 13112 = 1)
- (2) On the edit screen, place the cursor on the item from which you want to delete the \* mark.
- (3) Operate the soft keys [READ ID], [INPUT], and [SAVE] in that order.

To clear all \* marks at a time, press soft key [UPDATEALL ID] (displayed when bit 1 (IDC) of parameter No. 11320 is set to 1).

**Editing the spindle information screen**

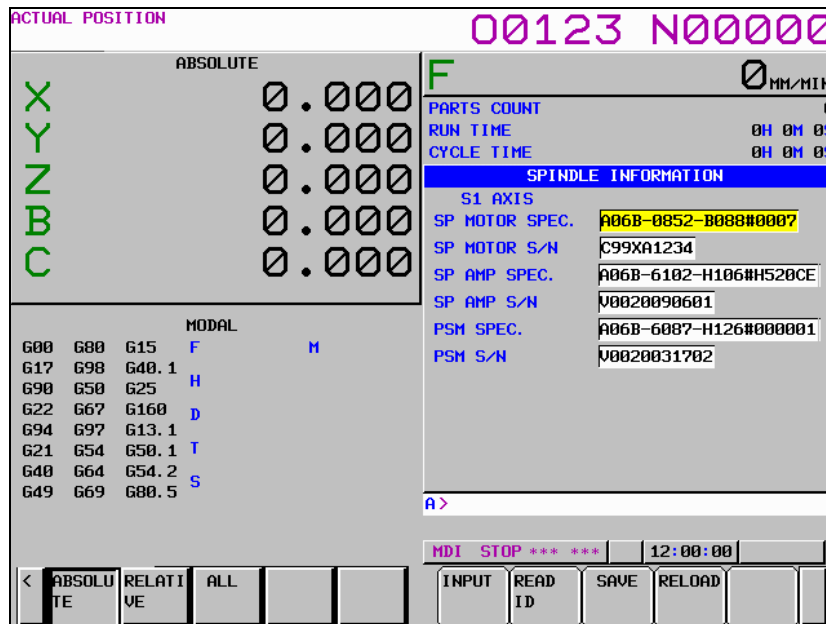
- 1 Assume that bit 0 (IDW) of parameter No. 13112 = 1 and bit 1 (IDC) of parameter No. 11320 = 1.
- 2 Press the MDI switch on the machine operator's panel.
- 3 Follow the steps shown in "Displaying the spindle information screen" to display the screen as shown below.



- 4 To move key-in buffer on the screen, use the page keys  and .

**Screen operation on the editing screen**

Mode	Key operation	Use
Viewing (*1)	Page key	Scrolls up or down on a screen-by-screen basis.
Editing (*2)	Soft key	
	[INPUT]	Replace the selected ID information at the cursor position with the character string in key-in buffer.
	[CANCEL]	Deletes the character string in key-in buffer.
	[READ ID]	Transfers the ID information the connected device at the cursor has to the key-in buffer. Only the items preceded by * (*3) are valid.
	[SAVE]	Saves the ID information that has been changed on the spindle information screen in flash ROM.
	[RELOAD]	Cancels the ID information that has been changed on the spindle information screen and loads ID information from flash ROM.
	[UPDATEALL ID] (*4)	Updates the ID information for all axes that is output from each of the connected units displayed on the servo or spindle information screen at a time.
	Page key	Scrolls up or down on a screen-by-screen basis.
	Cursor key	Scrolls up or down the selection of ID information.

- \*1 Viewing mode: when bit 0 (IDW) of parameter No. 13112 = 0
- \*2 Editing mode: when bit 0 (IDW) of parameter No. 13112 = 1
- \*3 Spindle information is stored in flash ROM. If there is a difference between the ID information in screen and the actual ID information, the corresponding items are preceded by \*.
- \*4 when bit 1 (IDC) of parameter No. 11320 = 1

ACTUAL POSITION		00123 N00000	
X Y Z B C	ABSOLUTE	0.0000	F <span style="float:right">MM/MIN</span>
		0.0000	PARTS COUNT 0
		0.0000	RUN TIME 0H 0M 0S
		0.0000	CYCLE TIME 0H 0M 0S
		0.0000	
MODAL		SPINDLE INFORMATION	
G00 G80 G15	F M	S1 AXIS	
G17 G98 G40.1		SP MOTOR SPEC.	A06B-0852-B088#0007
G90 G50 G25	H	SP MOTOR S/N	C99XA1234
G22 G67 G160	D	*SP AMP SPEC.	A06B-6102-H106#H520CE
G94 G97 G13.1		*SP AMP S/N	M0020090601
G21 G54 G50.1	T	PSM SPEC.	A06B-6087-H126#000001
G40 G64 G54.2	S	PSM S/N	M0020031702
G49 G69 G80.5		A >	
		MDI STOP *** ** 12:00:00	
< ABSOLUTE	RELATIVE	ALL	INPUT READ ID SAVE RELOAD

**NOTE**

The ID information of the spindle motor is not displayed automatically. To display the ID information, enter it manually in the edit mode.

# 10 TROUBLESHOOTING

This chapter describes troubleshooting procedure.

- 10.1 CORRECTIVE ACTION FOR FAILURES .....532
- 10.2 NO MANUAL OPERATION NOR AUTOMATIC OPERATION CAN BE EXECUTED.....534
- 10.3 JOG OPERATION CANNOT BE DONE .....537
- 10.4 HANDLE OPERATION CANNOT BE DONE .....540
- 10.5 AUTOMATIC OPERATION CANNOT BE DONE .....544
- 10.6 CYCLE START LED SIGNAL HAS TURNED OFF .....549
- 10.7 NOTHING IS DISPLAYED ON THE LCD WHEN THE POWER IS TURNED ON .....550
- 10.8 INPUT FROM AND OUTPUT TO I/O DEVICES CANNOT BE PERFORMED  
INPUT/OUTPUT CANNOT BE PERFORMED PROPERLY .....551
- 10.9 IN A CONNECTOR PANEL I/O UNIT, DATA IS INPUT TO AN UNEXPECTED ADDRESS553
- 10.10 IN A CONNECTOR PANEL I/O UNIT, NO DATA IS OUTPUT TO AN EXPANSION UNIT 554
- 10.11 ALARM SR0085 TO SR0087 (READER/PUNCHER INTERFACE ALARM).....555
- 10.12 ALARM PS0090 (REFERENCE POSITION RETURN IS ABNORMAL) .....559
- 10.13 ALARM DS0300 (REQUEST FOR REFERENCE POSITION RETURN) .....560
- 10.14 ALARM SV0401 (V READY OFF).....561
- 10.15 ALARM SV0404 (V READY ON) .....563
- 10.16 ALARM SV0462 (SEND CNC DATA FAILED)  
ALARM SV0463 (SEND SLAVE DATA FAILED) .....563
- 10.17 ALARM SV0417 (DIGITAL SERVO SYSTEM IS ABNORMAL) .....564
- 10.18 ALARM OH0700 (OVERHEAT: CONTROL UNIT) .....564
- 10.19 ALARM OH0701 (OVERHEAT: FAN MOTOR) .....565
- 10.20 ALARM SV5134 (FSSB: OPEN READY TIME OUT)  
ALARM SV5137 (FSSB: CONFIGURATION ERROR)  
ALARM SV5197 (FSSB: OPEN TIME OUT).....565
- 10.21 ALARM SV5136 (FSSB: NUMBER OF AMPS IS SMALL) .....566
- 10.22 SERVO ALARMS .....566
- 10.23 SPINDLE ALARMS.....566
- 10.24 SYSTEM ALARMS .....566
- 10.25 SYSTEM ALARMS RELATED TO THE PMC AND I/O Link .....575
- 10.26 LEDS ON UNITS SUPPORTING I/O LINK *i*.....584

## 10.1 CORRECTIVE ACTION FOR FAILURES

When a failure occurs, it is important to correctly grasp what kind of failure occurred and take appropriate action, to promptly recover the machine.

Check for the failure according to the following procedure :

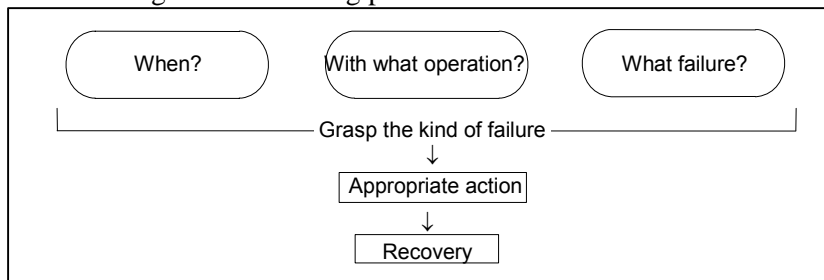

## 10.1.1 Investigating the Conditions under which Failure Occurred

(1) When and how many times (frequency of occurrences)

(2) With what operation

(3) What failure occurred

If the alarm issued is a system alarm, obtain system alarm information while referencing the descriptions in Section 10.24.

### 1 When did the failure occur?

- Date and time?
- Occurred during operation? (how long was the operation?)
- Occurred when the power was turned on?
- Was there any lightning surge, power failure, or other disturbances to the power supply?

How many times has it occurred

- Only once?
- Occurred many times ? (How many times per hour, per day, or per month?)

### 2 With what operation did it occur ?

- What was the NC mode when the failure occurred?  
Jog mode/memory operation mode /MDI mode /reference position return mode
- If during program operation,
  - Where in the program ?
  - Which program No. and sequence No. ?
  - What program ?
  - Occurred during axial movement ?
  - Occurred during the execution of an M/S/T code ?
  - Failure specific to the program ?
- Does the same operation cause the same failure ?  
(Check the repeatability of the failure.)
- Occurred during data input/output ?

<Feed axes and spindles>

- For a failure related to feed axis servo
  - (1) Occurred at both low feedrate and high feedrate ?
  - (2) Occurred only for a certain axis ?
- For a failure related to spindles  
When did the failure occur ? (during power-on, acceleration, deceleration, or constant rotation)

### 3 What failure occurred ?

- Which alarm was displayed on the alarm display screen?  
(Check the axis along which an alarm has occurred for alarms SV alarms, OT alarms, or SP alarms.)
- Is the screen correct ?
- If machining dimensions are incorrect
  - (1) How large is the error ?
  - (2) Is the position display on the CRT correct ?
  - (3) Are the offsets correct ?

### 4 Other information

- Is there noise origin around machine?  
If the failure has not occurred frequently, the cause may be external noise to the power supply or inductive noise on machinery cables.  
Operate other machines connected to the same power line and see if noise come from the relays or compressors.

- Is it taken any countermeasure for noise in machine side?  
See Section 2.8, “CAUTIONS RELATED TO GROUNDING AND NOISE”.
  - Check the following for the input power supply voltage :
    - (1) Is there variation in the voltage ?
    - (2) Are the voltages different depending on the phase ?
    - (3) Is the standard voltage supplied ?
  - How high is the ambient temperature of the control unit?  
Refer to manual about noise.
  - Has excessive vibration been applied to the control unit?
- 5 When you contact our service center, specify the following items :
- (1) Name of the NC unit
  - (2) Name of the machine tool builder and type of machine
  - (3) Software series/version of the NC
  - (4) Specifications of the servo amplifier and motor  
(for a failure related to the servo)
  - (5) Specifications of the spindle amplifier and spindle motor  
(for a failure related to a spindle)
    - See the drawing issued by the machine tool builder for the locations of the NC unit and servo/spindle amplifiers.
    - We use the following specification codes :  
Servo /spindle amplifier : A06B-xxxx-Hxxx  
Servo/spindle amplifier : A06B-xxxx-Bxxx

**NOTE**  
The mark ‘x’ represents a number.

## 10.2 NO MANUAL OPERATION NOR AUTOMATIC OPERATION CAN BE EXECUTED

### Points

- (1) Execute the following procedure when no manual nor automatic operation is done
- (2) Check whether position display shows correct position
- (3) Check CNC status display
- (4) Check CNC internal status using diagnosis function

### Causes and Countermeasures

#### 1 Position display (relative, absolute, machine coordinate) does not change

- (1) Check CNC status display (Refer to Section, “CNC STATUS DISPLAY” for detail.)
  - (a) Emergency stop status (Emergency stop signal is turned on)  
If status display shows **EMG** the emergency stop signal is input. Check the following signal using the PMC's diagnosis function (PMCDGN).

	#7	#6	#5	#4	#3	#2	#1	#0
<b>X0008</b>				<b>*ESP</b>				
<b>G0008</b>				<b>*ESP</b>				

\*ESP : ESP=0 indicates that emergency stop signal is input.



- (b) It is a reset status  
When RESET is displayed, any of a reset is functioned. Check the following signal using the PMC's diagnosis function (PMCDGN).

- (i) An input signal from the PMC functions

	#7	#6	#5	#4	#3	#2	#1	#0
<b>G0008</b>	<b>ERS</b>	<b>RRW</b>						

ERS : When ERS is 1, external reset signal is input.  
RRW : When RRW is 1, reset & rewind signal is input.

- (ii) RESET key on the MDI unit functions  
When the signals in 1) are 0, <RESET> key may be functioning. Check the contact of <RESET> key using a tester.  
When it is abnormal, change the MDI unit.

- (c) Confirm the status of modes  
Operation mode status is displayed on the lower part of screen as follows :  
If nothing is displayed, mode select signal is not input. Check mode select signal using PMC's diagnosis function (PMCDGN).  
For details, refer to section, "CNC STATUS DISPLAY".

(Example of display)

JOG : Manual operation (JOG) mode  
HND : Manual handle (MPG) mode  
MDI : Manual data input (MDI) mode  
MEM : Automatic operation (Memory) mode  
EDIT : EDIT (Memory edit) mode

<Mode select signal>

	#7	#6	#5	#4	#3	#2	#1	#0
<b>G0043</b>						<b>MD4</b>	<b>MD2</b>	<b>MD1</b>
						↓	↓	↓
	<b>Manual operation (JOG) mode</b>					1	0	1
	<b>Manual handle (MPG) mode</b>					1	0	0
	<b>Manual data input (MDI) mode</b>					0	0	0
	<b>Automatic operation (Memory) mode</b>					0	0	1
	<b>EDIT (Memory edit) mode</b>					0	1	1

- (2) Check CNC diagnosis data No. 0000, 1010. Check the items for which 1 is displayed at right side.

<b>0000</b>	
A. Inposition Check	0
Feedrate Override 0%	0
B. Jog Feed Override 0%	0
C. Inter/Start Lock on	1
Speed Arrival on	0
Wait Revolution	0
Stop Position Coder	0
Feed Stop	0

<b>1010</b>					<b>RST</b>	<b>ERS</b>	<b>RRW</b>	<b>ESP</b>
D.	0	0	0	0	0	0	0	0

\* Items with (a) to (d) relate with manual and automatic operation and its detail is shown below.

- (a) In-position check is being done  
It shows that positioning is not yet completed. Check the following diagnosis data. (It is 1 in the following condition)

DGN0300 Position Error > PARAM1826 In-position width

- (i) Check the parameters according to the parameter list.

<b>1825</b>	<b>Servo loop gain per axis (Normal : 3000)</b>
-------------	---

- (b) Jog feedrate override is 0%  
Check the signals using the PMC's signal status screen.

<b>G0010</b>	<b>#7</b>	<b>#6</b>	<b>#5</b>	<b>#4</b>	<b>#3</b>	<b>#2</b>	<b>#1</b>	<b>#0</b>
	<b>*JV7</b>	<b>*JV6</b>	<b>*JV5</b>	<b>*JV4</b>	<b>*JV3</b>	<b>*JV2</b>	<b>*JV1</b>	<b>*JV0</b>
<b>G0011</b>	<b>*JV15</b>	<b>*JV14</b>	<b>*JV13</b>	<b>*JV12</b>	<b>*JV11</b>	<b>*JV10</b>	<b>*JV9</b>	<b>*JV8</b>

When the override is 0% all bits of the above address becomes 1111 . . . . 1111 or 0000 . . . . 0000.

<b>*JV15 . . . . . *JV0</b>	<b>Override</b>
1111 1111 1111 1111	0.00%
1111 1111 1111 1110	0.01%
:	:
1101 1000 1110 1111	100.00%
:	:
0000 0000 0000 0001	655.34%
0000 0000 0000 0000	0.00%

- (c) Interlock or start lock signal is input  
There are a plural interlock signals. Check at first which interlock signal is used by the machine tool builder at the parameters shown below.

<b>3003</b>	<b>#7</b>	<b>#6</b>	<b>#5</b>	<b>#4</b>	<b>#3</b>	<b>#2</b>	<b>#1</b>	<b>#0</b>
						<b>ITX</b>		<b>ITL</b>

- #0 (ITL) ITL=0 shows interlock signal \*IT is effective. To 1)
- #2 (ITX) ITX=0 shows interlock signal \*ITn is effective. To 2)

Check state of effective interlock signals using the PMC's signal status screen.

- (i) Interlock signals (\*IT, \*CSL, and \*BSL) are input.

<b>G0008</b>	<b>#7</b>	<b>#6</b>	<b>#5</b>	<b>#4</b>	<b>#3</b>	<b>#2</b>	<b>#1</b>	<b>#0</b>
					<b>*BSL</b>		<b>*CSL</b>	<b>*IT</b>

\*IT=0, \*CSL=0, and \*BSL=0 show that interlock signal is input.

- (ii) Axis interlock signal (\*ITn) is input.

<b>G0130</b>	<b>#7</b>	<b>#6</b>	<b>#5</b>	<b>#4</b>	<b>#3</b>	<b>#2</b>	<b>#1</b>	<b>#0</b>
	<b>*IT8</b>	<b>*IT7</b>	<b>*IT6</b>	<b>*IT5</b>	<b>*IT4</b>	<b>*IT3</b>	<b>*IT2</b>	<b>*IT1</b>

\*ITn=0 shows interlock signal is input.

- (d) The NC is in the reset state.  
In this state, "RESET" is display as the state indication of the previous item 1-(1)-(b). So, not only manual operation but also all automatic operations are disabled. So, referring to the Section "Manual and Automatic Operations are Disabled", make an investigation.
- (e) The address to which an axis signal is assigned is incorrect.  
The relationship between each CNC axis and PMC interface address is set in a parameter. Check the setting of the following parameter:

3021	Address to which an axis signal is assigned
------	---

## 2 When machine coordinate value does not update on position display

Machine lock signal (MLK) is input.

	#7	#6	#5	#4	#3	#2	#1	#0
G0044							MLK	

G0108	MLK8	MLK7	MLK6	MLK5	MLK4	MLK3	MLK2	MLK1
-------	------	------	------	------	------	------	------	------

MLK : All axes machine lock

MLKn : Each axis machine lock

When the signal is 1, the corresponding machine lock signal is input.

# 10.3 JOG OPERATION CANNOT BE DONE

## Points

- (1) Check whether position display is operating.
- (2) Check CNC status display.
- (3) Check internal status using Diagnostic function.

## Causes and Countermeasures

### 1 Position display (relative, absolute, machine coordinate) does not change

- (1) Check mode selection status (JOG mode is not selected).  
 When status display shows JOG, it is normal.  
 When status display does not show JOG, mode select signal is not selected correctly. Confirm the mode select signal using the PMC's signal status screen.

<Mode select signal>

	#7	#6	#5	#4	#3	#2	#1	#0
G0043						MD4	MD2	MD1
						↓	↓	↓
	Manual operation (JOG) mode					1	0	1

- (2) Feed axis and direction select signal is not input Check the signal using the PMC's signal status screen.

	#7	#6	#5	#4	#3	#2	#1	#0
G0100	+J8	+J7	+J6	+J5	+J4	+J3	+J2	+J1

G0102	-J8	-J7	-J6	-J5	-J4	-J3	-J2	-J1
-------	-----	-----	-----	-----	-----	-----	-----	-----

When a bit is "1", the corresponding feed axis direction selection signal has been entered.

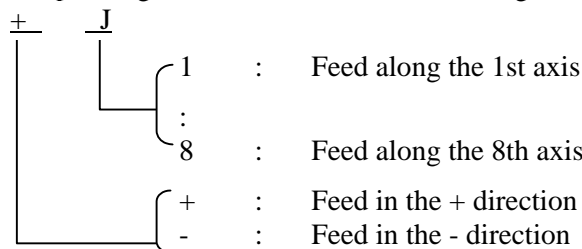

Example)

In the normal state, pressing the "+X" button on the operator's panel causes the signal +Jn to be displayed as "1".

- \* This signal becomes effective when the rise of the signal is detected. If, therefore, the direction selection signal has been entered before jog mode selection, axis movement is not performed; set the bit "0" and then re-check the signal.

(3) Check CNC diagnosis data No. 0000, 1010. Check the items for which 1 is displayed at right side.

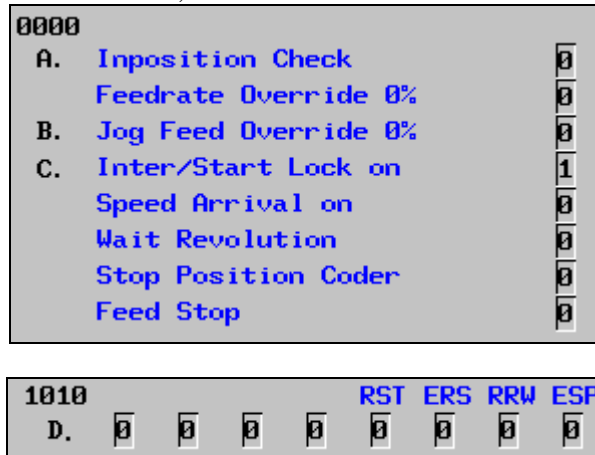

\* Items with (a) to (d) relate with manual and automatic operation and its detail is shown below.

(a) In-position check is being done

It shows that positioning is not yet completed. Check the following diagnosis data. (It is 1 in the following condition)

DGN0300 Position Error>Parameter No.1826 In-position width

(i) Check the parameters according to the parameter list.

1825	Servo loop gain per axis (Normal : 3000)
------	--

(b) Jog feedrate override is 0%

Check the signals using the PMC's signal status screen.

	#7	#6	#5	#4	#3	#2	#1	#0
G0100	*JV7	*JV6	*JV5	*JV4	*JV3	*JV2	*JV1	*JV0
G0011	*JV15	*JV14	*JV13	*JV12	*JV11	*JV10	*JV9	*JV8

When the override is 0% all bits of the above address becomes 1111 . . . . 1111 or 0000 . . . . 0000.

*JV15 . . . . . *JV0	Override
1111 1111 1111 1111	0.00%
1111 1111 1111 1110	0.01%
:	:
1101 1000 1110 1111	100.00%
:	:
0000 0000 0000 0001	655.34%
0000 0000 0000 0000	0.00%

(c) Interlock or start lock signal is input

There are a plural interlock signals. Check at first which interlock signal is used by the machine tool builder at the parameters shown below.

	#7	#6	#5	#4	#3	#2	#1	#0
<b>3003</b>						ITX		ITL

#0 (ITL) ITL=0 shows interlock signal \*IT is effective. To 1)

#2 (ITX) ITX=0 shows interlock signal \*ITn is effective. To 2)

Check state of effective interlock signals using the PMC's signal status screen.

- (i) Interlock signal (\*IT) is input.

	#7	#6	#5	#4	#3	#2	#1	#0
<b>G0008</b>								*IT

\*IT=0 shows that interlock signal is input.

- (ii) Axis interlock signal (\*ITn) is input.

	#7	#6	#5	#4	#3	#2	#1	#0
<b>G0130</b>	*IT8	*IT7	*IT6	*IT5	*IT4	*IT3	*IT2	*IT1

\*ITn=0 shows interlock signal is input.

- (d) NC is in a reset state

In this state, not only manual operation but also automatic operation is disabled. Make an investigation according to the Section, "Manual Operation and Automatic Operation are Disabled."

- (4) Jog feed rate setting (Parameter) is not correct.

<b>1423</b>	<b>Jog feedrate per axis</b>
-------------	------------------------------

- (5) Manual feed per revolution is selected

This function feeds an axis synchronized with spindle rotation and whether this function is used or not is selected by the following parameter:

	#7	#6	#5	#4	#3	#2	#1	#0
<b>1402</b>					JRV			

JRV Jog feed and incremental feed are :

0 : Of feed per minute

1 : Of feed per revolution

- (a) When parameter JRV is set to 1, feed rate of the axis is calculated by synchronizing with rotation of the spindle. Therefore, rotate the spindle.
- (b) If the axis does not move even when the spindle is rotated, check the detector of the spindle (position coder) and the cable between the position coder and the CNC if it is short-circuited or ungrounded.
- (6) The specified axis is the index table indexing axis. <machining center system only>  
For the index table indexing axis (B-axis), jog feed, incremental feed, and manual handle feed cannot be performed.

# 10.4 HANDLE OPERATION CANNOT BE DONE

## Points

If manual handle operation cannot be performed, the probable causes include the following:

- The servo is not activated.
- Manual pulse generators are not connected properly to the I/O module.
- The I/O Link *i* or I/O Link of the I/O module is not allocated, or is not allocated properly.
- A related input signal is not input due to a parameter setting error.

Also use CNC diagnosis functions to check the internal status.

## Causes and Countermeasures

### 1 The servo is not activated

Check that the LED on the servo amplifier indicates "0". If a number other than "0" is indicated, the servo is not activated. In this state, even JOG operation and automatic operation cannot be operated.

Check the servo-related parameters and the wiring.

### 2 Checking the manual pulse generators

#### (1) Cable failures (such as breaks)

Examine the cables for faults such as breaks and short-circuits, referring to the figure below.

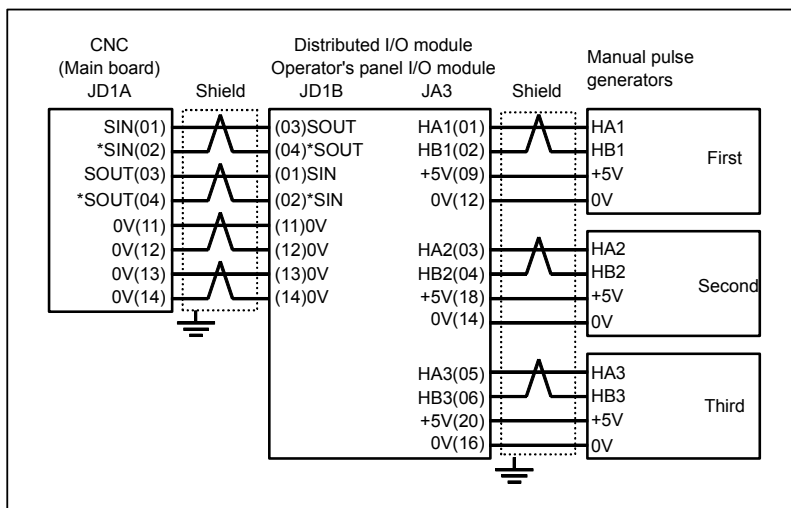
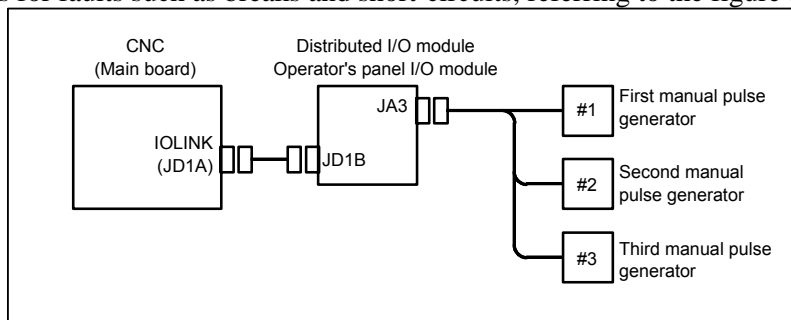

#### (2) Manual pulse generator failures

When rotated, a manual pulse generator generates the signals shown below.

Using an oscilloscope, measure the signals from the screw terminal block located at the rear of a manual pulse generator. If no signals are output, measure the +5 V voltage.

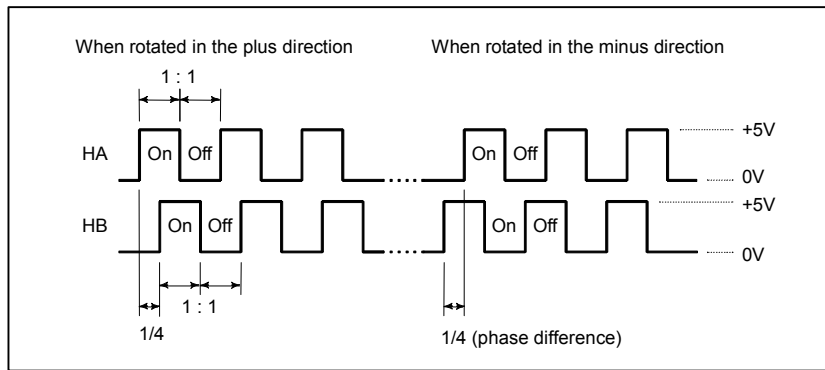
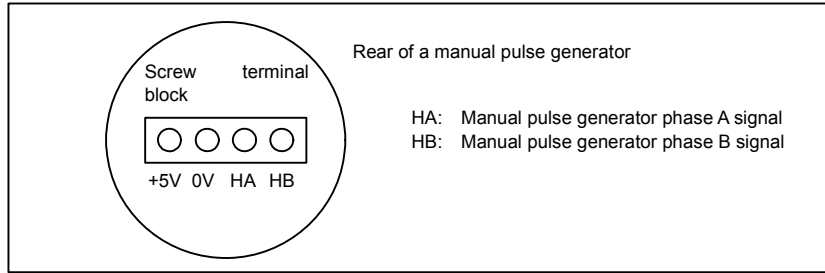

Check the on/off ratio and the phase difference between HA and HB.

### 3 Checking the parameters and input signals

See Section “CNC STATE DISPLAY.”

#### (1) Check CNC status display at lower left corner of the screen.

When the status display shows HND, mode selection is correct.

If it is not HND, mode select signal is not input correctly. Check the mode select signal using the PMC's signal status screen.

	#7	#6	#5	#4	#3	#2	#1	#0
G0043						MD4	MD2	MD1
						↓	↓	↓
						Manual handle mode	1	0

#### (2) Manual handle feed axis select signal is not input.

Check the signals using the PMC's signal status screen.

	#7	#6	#5	#4	#3	#2	#1	#0
G0018	HS2D	HS2C	HS2B	HS2A	HS1D	HS1C	HS1B	HS1A
G0019					HS3D	HS3C	HS3B	HS3A
G0020					HS4D	HS4C	HS4B	HS4A
G0379					HS5D	HS5C	HS5B	HS5A
G0411					HS4E	HS3E	HS2E	HS1E
G0412								HS5E

When axis select switch for manual handle feed is selected on the machine operator's panel, if the signals are input as follows, it is normal.

Selected axis	HSnE	HSnD	HSnC	HSnB	HSnA
no selection	0	0	0	0	0
1st axis	0	0	0	0	1
2nd axis	0	0	0	1	0
3rd axis	0	0	0	1	1
4th axis	0	0	1	0	0

Selected axis	HSnE	HSnD	HSnC	HSnB	HSnA
5th axis	0	0	1	0	1
6th axis	0	0	1	1	0
7th axis	0	0	1	1	1
8th axis	0	1	0	0	0
9th axis	0	1	0	0	1
10th axis	0	1	0	1	0
11th axis	0	1	0	1	1
12th axis	0	1	1	0	0
13th axis	0	1	1	0	1
14th axis	0	1	1	1	0
15th axis	0	1	1	1	1
16th axis	1	0	0	0	0
17th axis	1	0	0	0	1
18th axis	1	0	0	1	0
19th axis	1	0	0	1	1
20th axis	1	0	1	0	0
21st axis	1	0	1	0	1
22nd axis	1	0	1	1	0
23rd axis	1	0	1	1	1
24th axis	1	1	0	0	0

**NOTE**  
 In the above table, n is the number of the manual pulse generator (MPG) and up to 5 MPGs can be used. A feed axis is selected by 4-bit code of A to E.

**(3) Manual handle feed multiplication is not correct**

Check the following signals using the PMC's signal status screen. Also confirm the following parameters based on the parameter list.

	#7	#6	#5	#4	#3	#2	#1	#0
G0019			MP2	MP1				

In handle mode, the travel distance per step can be changed.

MP2	MP1	Step feed	Handle feed
0	0	× 1	× 1
0	1	× 10	× 10
1	0	× 100	× Mn
1	1	× 1000	× Nn

	#7	#6	#5	#4	#3	#2	#1	#0
7100			MPX					

- #5 MPX** In Manual handle feed mode, manual handle feed amount selection signal is
- 0: same for all manual pulse generator, and it is set by signals MP1 and MP2<Gn019.4,.5>.
  - 1: differ to each other manual pulse generator, and it's setting signal as follow:
    - 1st Manual Pulse Generator : MP1,MP2<Gn019.4,.5>
    - 2nd Manual Pulse Generator : MP21,MP22<Gn087.0,.1>
    - 3rd Manual Pulse Generator : MP31,MP32<Gn087.3,.4>
    - 4th Manual Pulse Generator : MP41,MP42<Gn087.6,.7>
    - 5th Manual Pulse Generator : MP51,MP52<Gn380.0,.1>



	#7	#6	#5	#4	#3	#2	#1	#0
7102								HNGx

**#0 HNGx** Axis movement direction for rotation direction of manual pulse generator  
 0: Same in direction  
 1: Reverse in direction

7113	Manual handle feed magnification m
7114	Manual handle feed magnification n
7131	Manual handle feed magnification m2 / 2nd. manual pulse generator
7132	Manual handle feed magnification n2 / 2nd. manual pulse generator
7133	Manual handle feed magnification m3 / 3rd. manual pulse generator
7134	Manual handle feed magnification n3 / 3rd. manual pulse generator
7135	Manual handle feed magnification m4 / 4th. manual pulse generator
7136	Manual handle feed magnification n4 / 4th. manual pulse generator
7137	Manual handle feed magnification m5 / 5th. manual pulse generator
7138	Manual handle feed magnification n5 / 5th. manual pulse generator

**(4) The specified axis is the index table indexing axis. <machining center system only>**

For the index table indexing axis (B-axis), jog feed, incremental feed, and manual handle feed cannot be performed.

**4 Checking the CNC diagnosis functions**

(1) Check CNC diagnosis data No. 0000, 1010. Check the items for which 1 is displayed at right side.

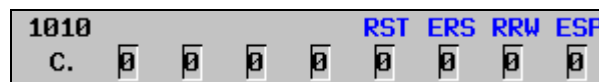
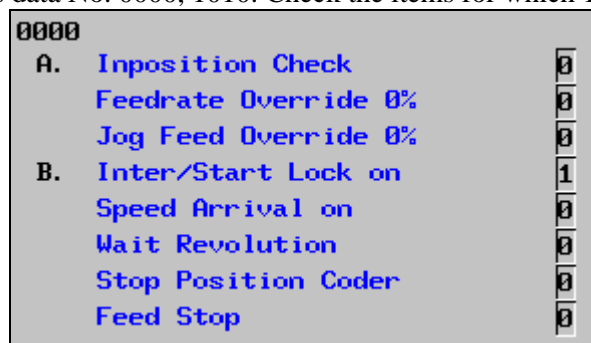

\* Items with (a) to (c) relate with manual and automatic operation and its detail is shown below.

(a) In-position check is being done

It shows that positioning is not yet completed. Check the following diagnosis data. (It is 1 in the following condition)

DGN0300 Position Error>Parameter No.1826 In-position width

- (i) Check the parameters according to the parameter list.

1825	Servo loop gain per axis (Normal : 3000)
------	--

- (b) Interlock or start lock signal is input

There are a plural interlock signals. Check at first which interlock signal is used by the machine tool builder at the parameters shown below.

3003	#7	#6	#5	#4	#3	#2	#1	#0
						ITX		ITL

- #0 (ITL) ITL=0 shows interlock signal \*IT is effective. To 1)
- #2 (ITX) ITX=0 shows interlock signal \*ITn is effective. To 2)

Check state of effective interlock signals using the PMC's signal status screen.

- (i) Interlock signal (\*IT) is input.

G0008	#7	#6	#5	#4	#3	#2	#1	#0
								*IT

\*IT=0 shows that interlock signal is input.

- (ii) Axis interlock signal (\*ITn) is input.

G0130	#7	#6	#5	#4	#3	#2	#1	#0
	*IT8	*IT7	*IT6	*IT5	*IT4	*IT3	*IT2	*IT1

\*ITn=0 shows interlock signal is input.

- (c) NC is in a reset state

In this state, not only manual operation but also automatic operation is disabled. Make an investigation according to the Section, "Manual Operation and Automatic Operation are Disabled."

## 10.5 AUTOMATIC OPERATION CANNOT BE DONE

### Points

- (1) Check manual operation is possible.
- (2) Check the status of cycle start LED on machine operator's manual.
- (3) Check status of CNC.

### Causes and Countermeasures

When manual operation is either impossible, perform countermeasure, based on the Section, "Jog Operation cannot be done".

Confirm that a correct mode is selected according to the mode select status of CNC status display. Also, by confirming the automatic operation status it is possible to identify cycle operation, feed hold and cycle stop state.

#### 1 When cycle operation is not started (Cycle start LED does not light)

"\*\*\*\*\*" is displayed at status display on screen.

- (1) Mode select signal is not correct.

When the mode select signal is input correctly, following status display is done.

MDI : Manual data input mode (MDI)

MEM : Memory operation mode

RMT : Remote operation mode

If status display does not show a correct status, check the mode signal with following PMC's signal status screen.

	#7	#6	#5	#4	#3	#2	#1	#0
G0043			DNCI			MD4	MD2	MD1

DNCI	MD4	MD2	MD1	Mode select
-	0	0	0	Manual data input (MDI) mode
0	0	0	1	Automatic operation (MEM) mode
1	0	0	1	Remote operation mode

(2) Cycle start signal is not input

This signal turns 1 when cycle start button is pressed and turns 0 when it is released. The cycle start actuates when it changes from 1 to 0. Check the state of the signal using PMC's diagnosis function(PMCDGN).

	#7	#6	#5	#4	#3	#2	#1	#0
G0007						ST		

ST : Cycle start signal

(3) Feed hold signal is input

Under normal state, the feed hold signal is 1 when the feed hold button is not pressed.

Check the state of this signal using the PMC's diagnosis function (PMCDGN).

	#7	#6	#5	#4	#3	#2	#1	#0
G0008			*SP					

\*SP : Feed hold signal

## 2 When an automatic operation is in progress (Cycle start LED is lit)

CNC's status display shows "STRT" on the screen.

- (1) Check information displayed at CNC diagnosis data No. 0. Check the items for which 1 is displayed at the right side.

Diagnosis	0	CNC internal state 1
-----------	---	----------------------

[Data type] Bit

	NAME	Internal state when "1" is displayed
a	INPOSITION CHECK	In-position check is being done.
b	FEEDRATE OVERRIDE 0%	Feedrate override is 0%.
c	JOG FEED OVERRIDE 0%	Jog feedrate override is 0%.
d	INTER/START LOCK ON	Interlock/start lock is on.
e	SPEED ARRIVAL ON	The system is waiting for the speed arrival signal to turn on.
	WAIT REVOLUTION	The system is waiting for the spindle one-rotation signal in threading.
	STOP POSITION OCDER	The system is waiting for the rotation of the position coder in spindle feed per revolution.
	FEED STOP	A feed stop was made.

\* Items with a to e relate with an automatic operation and their details are as follows :

- (a) In-position check (confirming positioning) is being done  
 Positioning (G00) to a specified position of a specified axis is not completed. Whether positioning is completed or not is checked as the servo position error amount. Check it diagnosis data as follows:  
 Diagnosis 300  > Parameter No. 1826   
 Position error amount almost becomes 0, when positioning of an axis completes and when the amount becomes within the in-position width, it is assumed that positioning completes and the next block is executed.

- (b) Feedrate override is at 0%  
Actual feedrate is overridden by the override signals to a programmed feedrate.  
Check the override signals using the PMC's signal status screen.

• Normal override signal

	#7	#6	#5	#4	#3	#2	#1	#0
G0012	*FV7	*FV6	*FV5	*FV4	*FV3	*FV2	*FV1	*FV0

\*FVn : Feedrate override  
<2nd override signal (option)>  
Feed rate is overridden more finely using the signals below:  
See MTB's manual whether this feature is equipped.

	#7	#6	#5	#4	#3	#2	#1	#0
G0013	*AFV7	*AFV6	*AFV5	*AFV4	*AFV3	*AFV2	*AFV1	*AFV0

\*AFVn : 2nd feed rate override

• State of override signal

*FV7 . . . . . *FV0	
1 1 1 1 1 1 1 1	0%
1 1 1 1 1 1 1 0	1%
:	:
1 0 0 1 1 0 1 1	100%
:	:
0 0 0 0 0 0 0 1	254%
0 0 0 0 0 0 0 0	0%

*AFV7 . . . *AFV0	
1 1 1 1 1 1 1 1	0%
1 1 1 1 1 1 1 0	1%
:	:
1 0 0 1 1 0 1 1	100%
:	:
0 0 0 0 0 0 0 1	254%
0 0 0 0 0 0 0 0	0%

- (c) Manual feedrate override is 0% (dry run)  
Normally manual feedrate override function is used for jog feed.  
But when DRN(dry run) signal turns on during an automatic operation, override values set with these signals become valid to the following speed set by a parameter.

	#7	#6	#5	#4	#3	#2	#1	#0
G0046	DRN							

Dry run signal is input with this signal being 1.

1410	Dry run rate
------	--------------

The rate when the following override value is 100%.

	#7	#6	#5	#4	#3	#2	#1	#0
G0010	*JV7	*JV6	*JV5	*JV4	*JV3	*JV2	*JV1	*JV0

G0011	*JV15	*JV14	*JV13	*JV12	*JV11	*JV10	*JV9	*JV8
-------	-------	-------	-------	-------	-------	-------	------	------

When override value is 0%, all bits of the above address is [1111 . . . . 1111] or [0000 . . . . 0000].

*JV15 . . . . . *JV0	Override
1111 1111 1111 1111	0.00%
1111 1111 1111 1110	0.01%
:	:
1101 1000 1110 1111	100.00%
:	:
0000 0000 0000 0001	655.34%
0000 0000 0000 0000	0.00%

## (d) Interlock signal is input

There are a plural number of interlock functions. Parameters are set by machine tool builders for which interlock function is used.

Therefore, confirm the following parameters at first:

	#7	#6	#5	#4	#3	#2	#1	#0
<b>3003</b>						ITX		ITL

ITL 0: Interlock signal(\*IT) is valid.

ITX 0: Interlock signal (\*ITn) is valid.

Confirm which interlock signal is activated by the PMC's signal status screen.

## (i) Interlock signals (\*IT, \*CSL, and \*BSL) are input.

	#7	#6	#5	#4	#3	#2	#1	#0
<b>G0008</b>					*BSL		*CSL	*IT

\*IT=0, \*CSL=0, and \*BSL=0 show that interlock signal is input.

## (ii) Interlock signal per each axis (\*ITn) is input

	#7	#6	#5	#4	#3	#2	#1	#0
<b>G0130</b>	*IT8	*IT7	*IT6	*IT5	*IT4	*IT3	*IT2	*IT1

\*ITn When the bit is 0, the corresponding axis's interlock signal is input.

## (iii) Controlled axis detach function is running. A detached axis is specified for travelling.

\* This function is valid when bit 7 (RMBx) of CNC parameter No. 1005=1. For whether this function is running or not, confirm the following signal using the PMC's signal status screen. Check the axis concerned.

## 1) The control axis detach signal (DTCHn) is input.

	#7	#6	#5	#4	#3	#2	#1	#0
<b>G0124</b>	DTCH8	DTCH7	DTCH6	DTCH5	DTCH4	DTCH3	DTCH2	DTCH1

DTCHn If it is 1, the corresponding axis is detached.

## 2) The following parameter enables the control axis detach function to the corresponding axis.

	#7	#6	#5	#4	#3	#2	#1	#0
<b>0012</b>	RMVx							

RMVx Releasing the assignment of the control axis for each axis

0: Not released

1: Released

(Equivalent to the control axis detachment signals DTCH1, DTCH2, and so forth)

## (e) CNC is waiting for spindle speed arrival signal to be input

Actual spindle speed does not arrive at a speed specified in a program.

Confirm the signal state using the PMC's signal status screen.

	#7	#6	#5	#4	#3	#2	#1	#0
<b>G0029</b>				SAR				

When this signal is 0, spindle speed does not arrive at the specified speed.

\* This function is valid when the bit 0 (SAR) of parameter No. 3708=1.

(2) Only rapid traverse in positioning (G00) does not function Confirm the following parameter and signals from the PMC.

(a) Setting value of rapid traverse rate

1420	Rapid traverse rate per axis
------	------------------------------

(b) Rapid traverse override signals

	#7	#6	#5	#4	#3	#2	#1	#0
G0014							ROV2	ROV1

G0096	HROV	*HROV6	*HROV5	*HROV4	*HROV3	*HROV2	*HROV1	*HROV0
	↳	(HROV=0)				(HROV=1)		

ROV1	ROV2	Override
0	0	100%
1	1	50%
0	1	25%
1	1	F0

*HROV6 . . . *HROV0	Override
1 1 1 1 1 1 1	0%
1 1 1 1 1 1 0	1%
:	:
0 0 1 1 0 1 1	100%

1421	Rapid traverse override F0 rate
------	---------------------------------

(3) Only feed (other than G00) does not function

(a) Maximum feedrate set by parameter is incorrect.

Feedrate (other than G00) is clamped at this upper feedrate.

1430	Maximum feedrate in each axis
------	-------------------------------

(b) Feedrate is specified by feed per revolution (mm/rev)

(i) Position coder does not rotate

Check the connection between spindle and position coder

The following failure is considered:

- Timing belt is broken
- Key is removed
- Coupling is loose
- Connector of signal cable is loosened

(ii) Position coder is faulty

(c) Thread cutting does not operate

(i) Position coder does not rotate

Check the connection between spindle and position coder

The following failure is considered:

- Timing belt is broken
- Key is removed
- Coupling is loose
- Connector of signal cable is loosened

(ii) Position coder is faulty

Position coder is connected to the spindle amplifier when serial interface spindle is used or connected to the CNC when analog interface spindle is used.

For details of connection, refer to the following.

Whether A/B phase signals from the position coder are read correctly, can be judged also by the spindle speed display on the screen (position screen).

(However, it is not displayed when bit 2 (DPS) of parameter No. 3105 is set to 0).

• *αi* series spindle amplifier

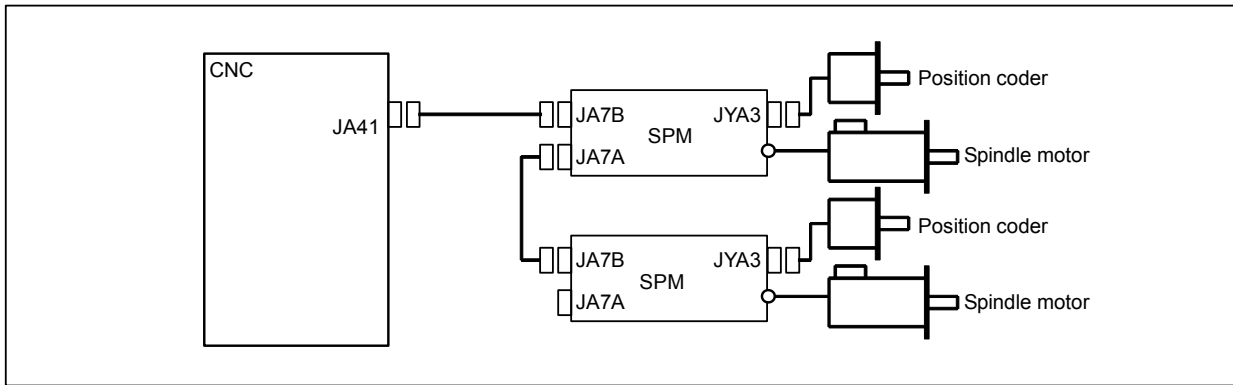

- (d) A cutting feed block containing a feedrate command (F command) with a feedrate of 0 is specified.  
 If the bit 7 (FCO) of parameter No. 1404 is set to 1, alarm PS0011, “FEED ZERO (COMMAND)” is not issued even if a feedrate command (F command) with a feedrate of 0 is issued.

## 10.6 CYCLE START LED SIGNAL HAS TURNED OFF

### Points

- (1) After cycle operation is started, then stopped, check as follows:
- (2) Confirm cycle start LED on machine operator's panel.
- (3) Confirm CNC's diagnosis function.

### Causes and Countermeasures

Check the states of the related signals on the signal status screen of PMC.

#### a. Emergency stop is input

	#7	#6	#5	#4	#3	#2	#1	#0
X0008				*ESP				
G0008				*ESP				

\*ESP=0 Emergency stop signal is input :

#### b. External reset signal is input

	#7	#6	#5	#4	#3	#2	#1	#0
G0008	ERS							

#7(ERS) When the bit is 1, external reset signal is input.

- \* This signal is usually used for a confirmation signal of M02 when an M02 is specified in a program as the end of a program.  
 Therefore, when M02 is executed, this signal is input.

#### c. Reset button on the MDI is pressed

An automatic operation is put into a reset status when  key on the MDI panel is pressed.

**d. Reset & rewind signal is input**

	#7	#6	#5	#4	#3	#2	#1	#0
G0008		RRW						

#6(RRW) When this signal is 1, the reset & rewind signal is input.

- \* This signal is usually used for a confirmation signal of M30 when an M30 is specified in a program as the end of a program. Therefore, when M30 is executed, this signal is input.

**e. Servo alarm has generated**

When any servo alarm has generated, cycle operation is put into the reset state and operation stop.

**f. Cycle operation is in a feed hold state**

The cycle operation becomes feed hold state in the following cases:

- (1) Modes are switched from an automatic operation mode to a manual operation mode.
- (2) Feed hold signal is input.

• **Mode select signal**

	#7	#6	#5	#4	#3	#2	#1	#0
G0043						MD4	MD2	MD1
						↓	↓	↓
Automatic operation	Memory edit (EDIT)					0	1	1
	Automatic operation (AUTO)					0	0	1
	Manual data input (MDI)					0	0	0
Manual operation	Jog feed (JOG)					1	0	1
	Handle/step					1	0	0
	TEACH IN HANDLE					1	1	1
	TEACH IN JOG					1	1	0

• **Feed hold signal**

	#7	#6	#5	#4	#3	#2	#1	#0
G0008			*SP					

#5(\*SP) When this signal is 0, the feed hold signal is input.

**g. It become single block stop during automatic operation**

	#7	#6	#5	#4	#3	#2	#1	#0
G0046							SBK	

#1(SBK) When this signal is 1, the single block signal is input.

## 10.7 NOTHING IS DISPLAYED ON THE LCD WHEN THE POWER IS TURNED ON

### Causes and Countermeasures

If nothing is displayed on the LCD at power-up or if the LCD is locked with "LOADING GRAPHIC SYSTEM", the probable causes include the following:

- **For the LCD-mounted type**
  - The LCD cable or backlight cable is not connected.
  - The necessary software is not installed.
  - The main board, display control card, CPU card, or inverter board is defective.



- **For the stand-alone type**

- The LCD unit is not connected to the power supply.
- The LCD cable or backlight cable is not connected.
- The LCD unit is not connected to the CNC with the optical cable or the cable is broken.
- The necessary software is not installed.
- The main board, display control card, or LCD unit is defective.

If “LOADING GRAPHIC SYSTEM” is displayed on a 15” display for the 30i/31i/32i, this indicates that the display control circuit has started up normally, but the CNC has not started up or communication with the CNC has not been established.

- **LED display**

Check which LED lights on the main board while referencing the item “LED display” of the main board. If the main board has started up normally and the LED display indicates normal operation, a probable cause is a fault of the display system, such as a cable not connected or a defective inverter board. If the LED display is locked in the middle of the startup process, the probable causes include defective hardware (or installation failure) and the necessary software not installed.

- **Connection of the LCD and backlight cables**

Check that the LCD and backlight cables are connected firmly to the corresponding connectors. These cables are connected before shipment from FANUC. This check is, however, required because the cables may be disconnected during maintenance.

- **The necessary software is not installed**

If necessary software is not stored in the FROM module, the CNC may not start up.

- **Defective printed circuit board**

If the main board or display control card is defective or is not correctly installed, the CNC may not start up.

Check that the card PCBs are engaged firmly with the connectors on the main board.

If any of the above actions does not solve the problem, replace the display control card, CPU card, and main board.

- **Installation positions of the display control card and CPU card**

Referring to Section, “MOUNTING AND DEMOUNTING CARD PCBS,” check the installation status.

## 10.8 INPUT FROM AND OUTPUT TO I/O DEVICES CANNOT BE PERFORMED, INPUT/OUTPUT CANNOT BE PERFORMED PROPERLY

---

### Causes and Countermeasures

If the I/O Link *i* or I/O Link is not established, if the signals from an I/O device cannot be input normally to the CNC, or if the signals from the CNC cannot be output to an I/O device, the probable causes include the following:

- The I/O device is not turned on, or the power supply is not at the appropriate voltage.
- The I/O Link *i* or I/O Link cable is not connected correctly or appropriately.
- The grounding is not correct.
- The input/output signals are not connected correctly.
- I/O Link *i* or I/O Link allocation is not performed, or is not performed properly.

**- PMC alarm  
ER97 IO LINK FAILURE**

If "ER97 I/O Link FAILURE(CHx Gyy)" is displayed on the alarm screen of the PMC, the number of I/O devices connected to channel xx of the I/O Link *i* or I/O Link is not the same as the number of devices allocated to the I/O Link *i* or I/O Link.

**- I/O Link screen of the PMC**

From the function key  menu, select [PMC MAINTEN] and [I/O DEVICE] in that order. The I/O devices recognized by the CNC are displayed. From this screen, the devices that are connected normally can be determined.

Screen display example

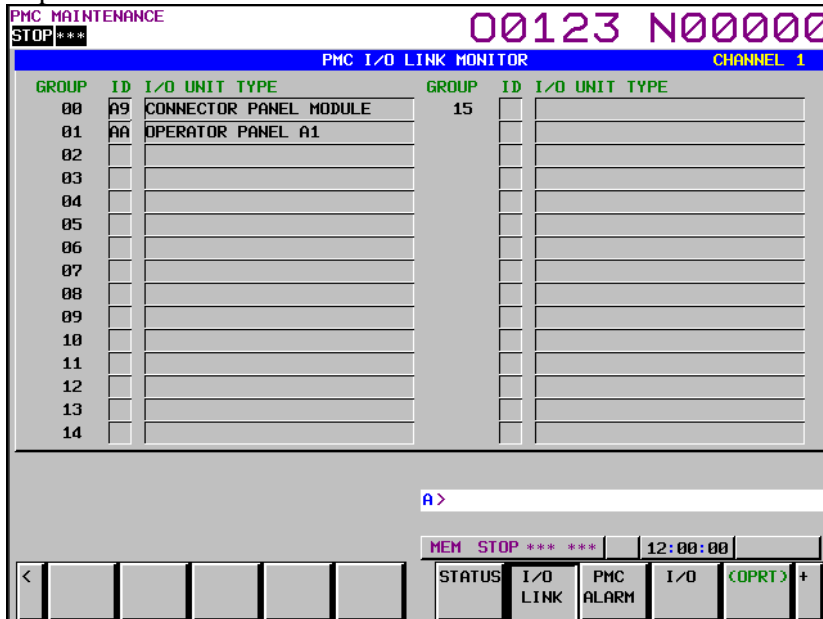

This example indicates that the I/O Link is as shown in the figure below.

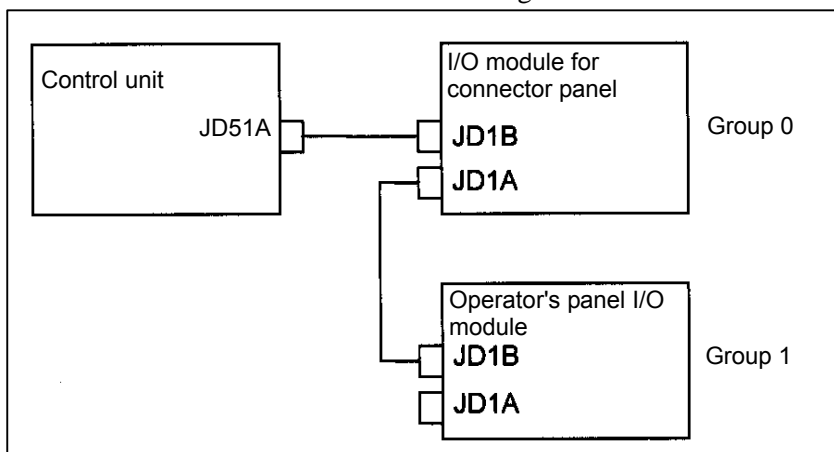

**- Checking the power supplies of the I/O devices**

Check that the connected I/O devices are connected properly to the power supplies and that the voltages are as prescribed.

Check that the power-on sequence is correct.

Time at which an I/O device is to be turned on

Before the CNC is turned on or within 500 ms after the CNC is turned on

When the CNC is turned off, the I/O devices must also be turned off. (Refer to Section “TURNING ON AND OFF THE POWER TO THE CONTROL UNIT” in the CONNECTION MANUAL (HARDWARE) (B-64483EN) for details)

### - Connection of cables

As in the example shown on the previous page, I/O Link *i* or I/O Link cables are used to connect JD1A (JD51A) and JD1B.

JD1A (JD51A) represents an upper unit while JD1B represents a lower unit. Check that the cables are connected correctly.

### - Connection of ground wires

Check that the ground wires are connected and are not loose.

### - Connection of I/O signals

Check that the input/output signals to be connected to each I/O device are connected correctly.

For operator's panel I/O modules and for connector panel I/O modules, also check that the 0 V or +24 V input signal is connected to the common pin and that the +24 V output signal is connected to the DO common pin.

### - I/O Link *i* or I/O Link allocation

Check that I/O Link *i* or I/O Link allocation has been performed correctly.

From the function key  menu, select [PMC CONF], [MODULE], and [EDIT] in that order. The allocation edit screen appears.

After editing allocation, be sure to write the sequence program onto the flash ROM using the PMC data I/O screen. Otherwise, the changes will be lost when the power is turned off.

## 10.9 IN A CONNECTOR PANEL I/O UNIT, DATA IS INPUT TO AN UNEXPECTED ADDRESS

If data is input to an invalid address in a connector panel I/O unit (for example, data that should be input to X004 is actually input to X010 in a connector panel I/O unit), the most likely causes are as follows:

- (1) The I/O Link *i* or I/O Link allocation is wrong.  
→ Perform the check described in Section 10.8.
- (2) The unit-to-unit cables (CA52-to-CA53) are not connected correctly.  
If the connection is wrong, expansion unit 1 is allocated the address of expansion unit 3, as shown below.  
→ Connect the unit-to-unit cables as shown below:

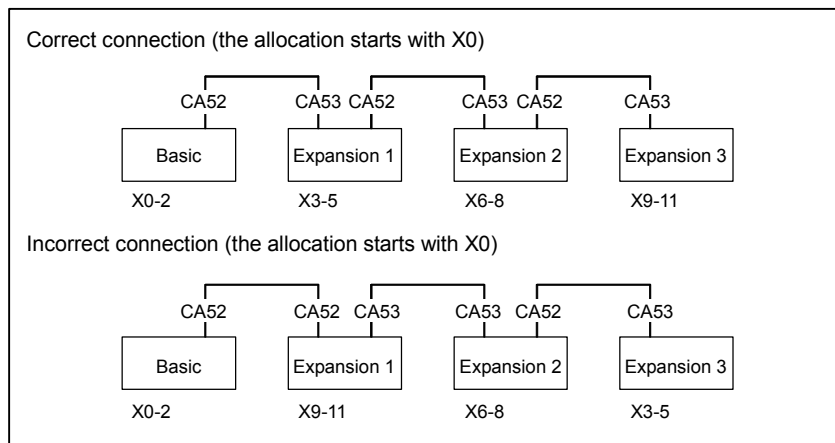

- (3) The setting of the rotary switch on an expansion unit is wrong  
 If the rotary switch is set to 1, one unit number is skipped. If set to 2, two unit numbers are skipped. Usually, the setting must be 0. (For those units without a rotary switch, unit numbers cannot be skipped.)

→ See the following example and refer to the Connection Manual (Hardware) (B-64483EN).

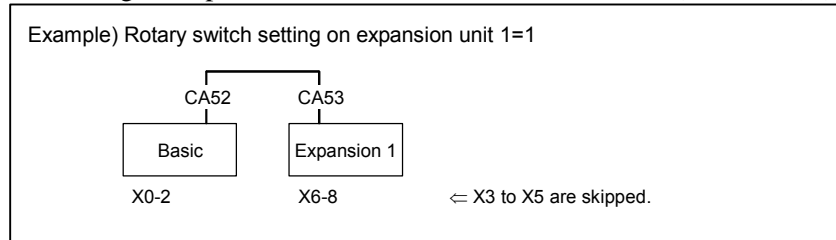

## 10.10 IN A CONNECTOR PANEL I/O UNIT, NO DATA IS OUTPUT TO AN EXPANSION UNIT

The most likely cause is that power is not being supplied to the expansion unit.

- Check whether +24-V power is supplied to No. 18 pin and No. 50 pin of the expansion unit, DI and DO signals are not input and output.
- Check whether +24-V power is supplied to No. 1 pin and No. 3 pin of the expansion unit, when DI signals are input and DO signals are not output.

## 10.11 ALARM SR0085 TO SR0087 (READER/PUNCHER INTERFACE ALARM)

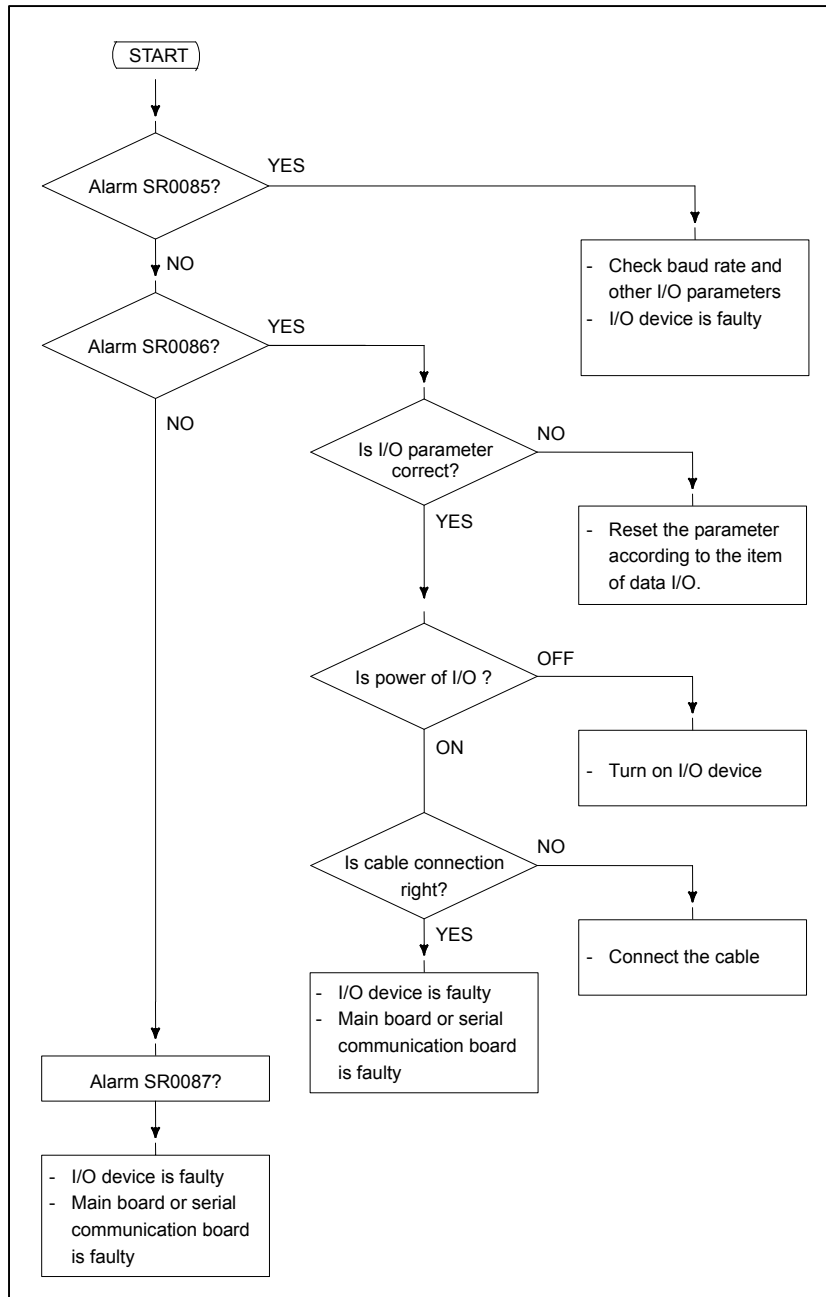

### Causes

- Parameters on reader/puncher interface are not correct.  
Check the following setting data and parameters.
- External I/O device or host computer is faulty.
- Main board or serial communication board is faulty.
- Cable between NC and I/O device is faulty.

### Countermeasures

- Parameters on reader/puncher interface are not correct.  
Check the following setting data and parameters:

**- Setting**

PUNCH CODE=0 OR 1 (0: EIA,1:ISO)

Select ISO or EIA according to the type of I/O device.

If punch code does not match, alarm SR0086, “DR OFF” will generate.

**- Parameter**

Function		Value of parameter 0020		
		0	1	2
Feed		0101#7	0111#7	0121#7
Data input code		0101#3	0111#3	0121#3
Stop bit		0101#0	0111#0	0121#0
Type of I/O device		102	112	122
Baud rate		103	113	123
Communication method		0135#3	-	-
Connector		RS-232C		
		Main board		
		JD56A	JD36A	

**NOTE**

Numbers in the table indicate parameters and bit numbers.

Example) 0101#7: Bit7 of parameter No. 0101.

	#7	#6	#5	#4	#3	#2	#1	#0
0101	NFD				ASI			SB2
0111								
0121								

NFD 0: Feed is output before and after data in data output (FANUC PPR)

1: Feed is not output (standard).

ASI 0: Data input code is EIA or ISO (automatic recognition)

1: Data input code is ASCII.

SB2 0: No. of stop bits is 1.

1: No. of stop bits is 2.

	Type of I/O device
0102	
0112	
0122	

Value	TYPE OF I/O DEVICE
0	RS-232-C (Used control codes DC1 to DC4)
1	FANUC CASSETTE ADAPTOR 1 (FANUC CASSETTE B1/ B2)
2	FANUC CASSETTE ADAPTOR 3 (FANUC CASSETTE F1)
3	FANUC PROGRAM FILE Mate, FANUC FA CARD ADAPTOR FANUC FLOPPY CASSETTE ADAPTOR, FANUC Handy File, FANUC SYSTEM P-MODEL H
4	RS-232-C (Not used control codes DC1 to DC4)
5	Portable tape reader
6	FANUC PPR, FANUC SYSTEM P-MODEL G, FANUC SYSTEM P-MODEL H

0103	Baud rate	
0113		
0123		

Value	Baud rate
7	600
8	1200
9	2400
10	4800

11	9600
12	19200

- (b) External I/O device or Host computer is in trouble
  - (i) Check whether the setting on communication of external I/O device or host computer is the same as that of the CNC. (baud rate, stop bits, etc.)  
If they are not the same, change the setting.
  - (ii) When spare I/O device presents, check whether it is possible to realize communication using the spare I/O device.
  
- (c) Main board or serial communication control module is faulty
  - (i) When parameter No.0020 is 0, 1, or 2 (JD56A, JD36A of Main board)  
Replace the module since main board may be faulty.
  
- (d) Cable between CNC and I/O device is faulty.  
Check the cable for disconnection or wrong connection.

**- Connection**

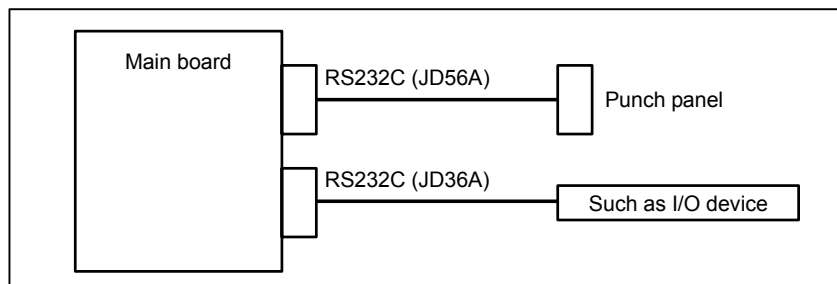

- Cable connection

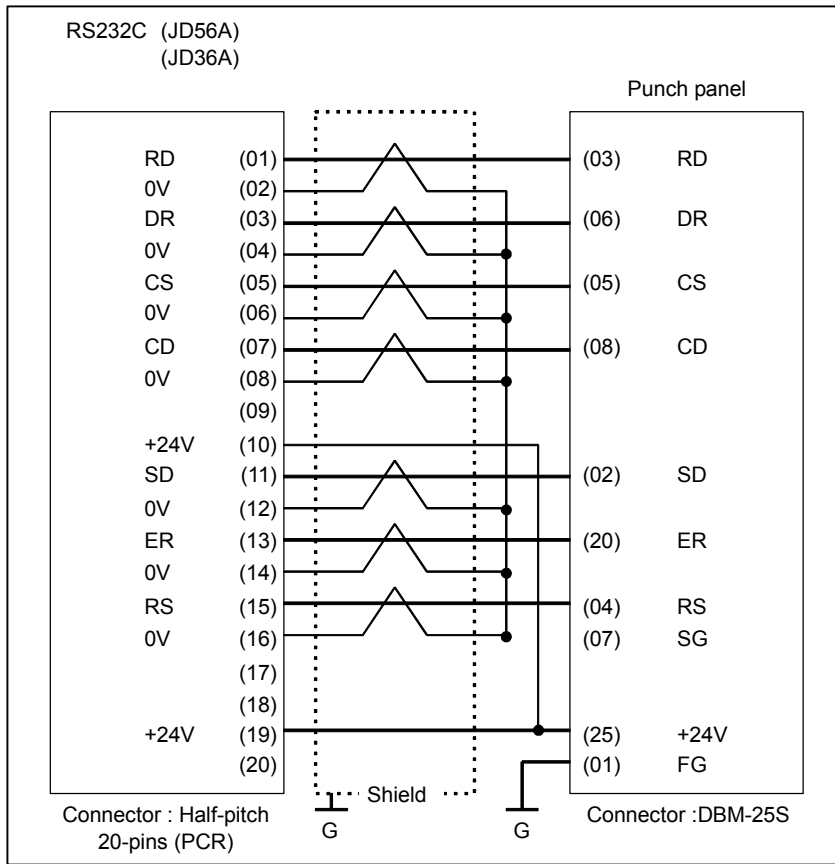



# 10.12 ALARM PS0090 (REFERENCE POSITION RETURN IS ABNORMAL)

## Contents

Reference position return was executed when the following condition is not satisfied:  
 The CNC received one rotation signal at least one time when the axis is moving to the reference position at a speed higher than a speed equivalent to 128 pulses of position error amount (DGN300).

## Countermeasures

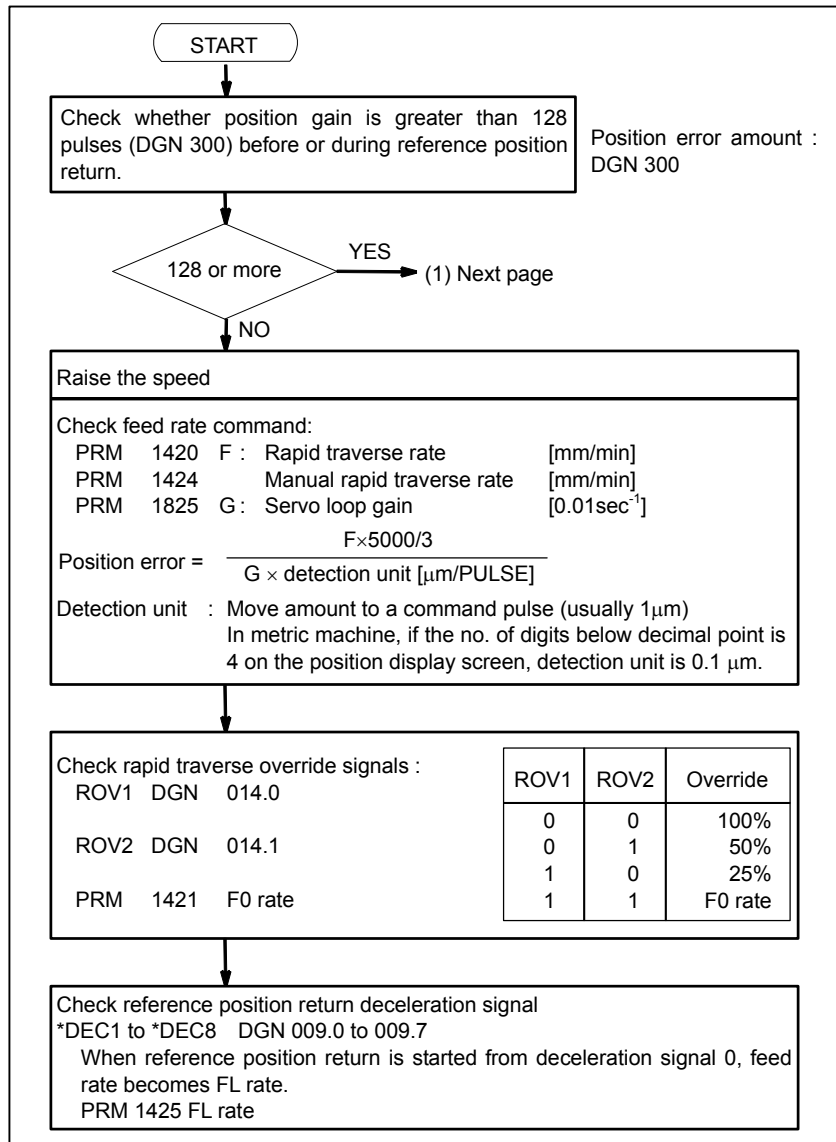

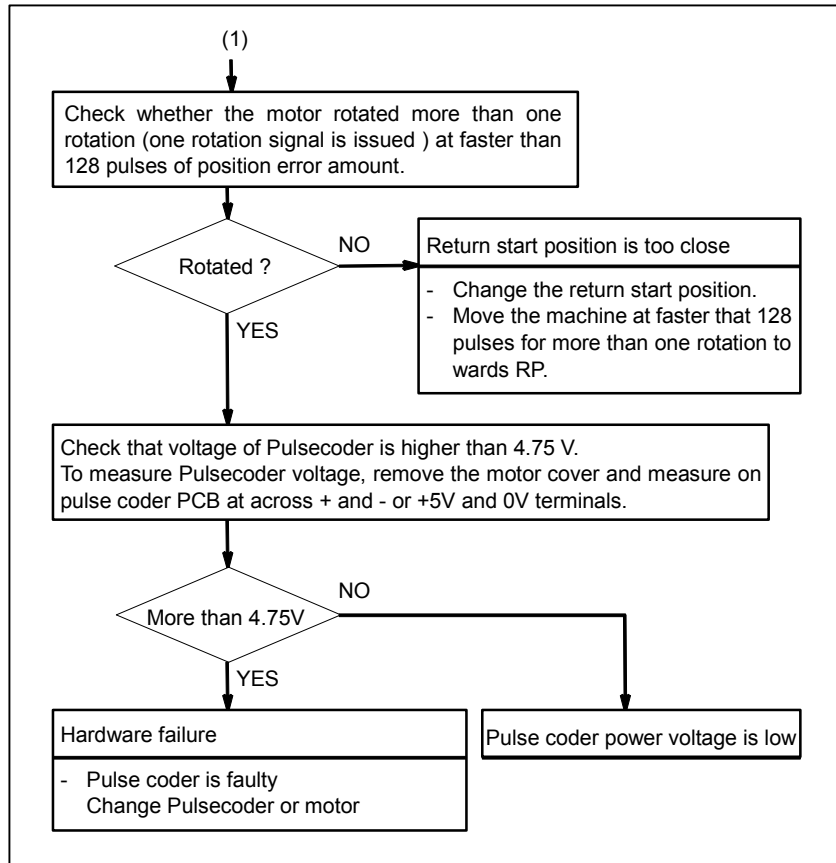

**⚠ CAUTION**

(1) After the Pulsecoder or motor is exchanged, reference position or machine's standard point may be different from former one. Please set it correctly.

**Reference**

A speed more than 128 pulses is required because if speed is lower that this, one-rotation signal does not function stably, causing improper position detection. If bit 0 of parameter No. 2000 is set to 1, a speed corresponding to a positional deviation of 1280 pulses or more is required.

Parameter No. 1836 can be set to 128 or less, as the minimum positional deviation with which reference position return is possible. (If the parameter is set to 0, 128 is assumed as the minimum positional deviation. If bit 0 of parameter No. 2000 is set to 1, a value equal to ten times the set value is used for checking.)

## 10.13 ALARM DS0300 (REQUEST FOR REFERENCE POSITION RETURN)

Absolute position data in the serial Pulsecoder was lost.

(This alarm will be generated when serial Pulsecoder is exchanged or position feedback signal cable of the serial Pulsecoder is disconnected).

**Countermeasures**

Machine position must be memorized using the following method:

- **When reference position return function is present**

- 1 Execute manual reference position return only for an axis for which this alarm was generated. When manual reference position return cannot be executed because of an another alarm, set bit 5 (APCx) of parameter No. 1815 to 0 and release the alarm and perform manual operation.
- 2 Press  key at the end of reference position return to release the alarm.

- **When reference position return function is not present**

Execute dogless reference position setting to memorize the reference position.

- **When serial Pulsecoder is changed**

Since the reference position is different from the former one, change the grid shift value (parameter No. 1850) to correct the position.

### Related parameters

	#7	#6	#5	#4	#3	#2	#1	#0
1815			APCx	APZx				

**#4 APZx** Machine position and position on absolute position detector when the absolute position detector is used

0: Not corresponding

1: Corresponding

When an absolute position detector is used, after primary adjustment is performed or after the absolute position detector is replaced, this parameter must be set to 0, power must be turned off and on, then manual reference position return must be performed. This completes the positional correspondence between the machine position and the position on the absolute position detector, and sets this parameter to 1 automatically.

**#5 APCx** Position detector

0: Other than absolute position detector

1: Absolute position detector (absolute pulse coder)

## 10.14 ALARM SV0401 (V READY OFF)

### Causes and Countermeasures

This alarm is issued if the servo ready signal VRDY of a servo amplifier does not turn on or if the signal turns off during operation.

There are cases in which this alarm is issued because another servo alarm is issued. If this occurs, first take the action for the first alarm.

Check the power magnetic circuit around the amplifier. The servo amplifier or the axis control cards on the CNC may be defective.

### - VRDY

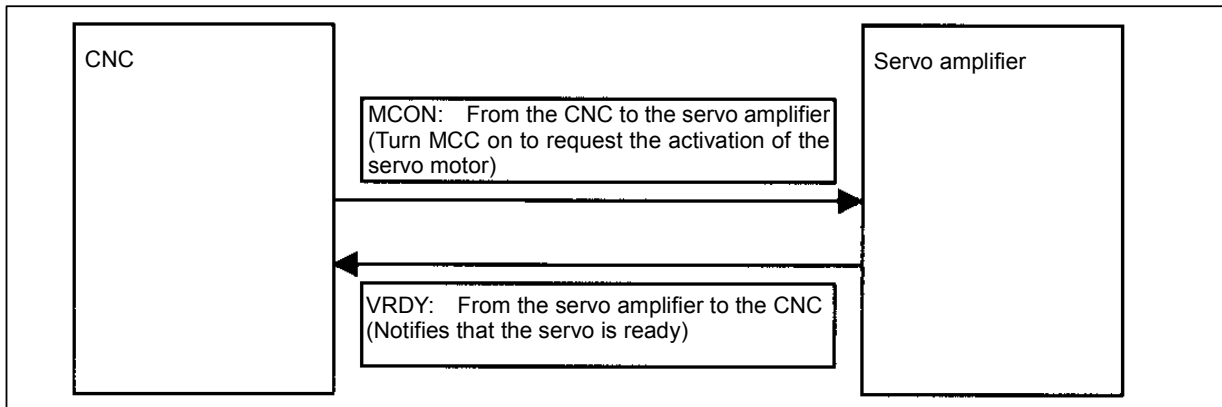

The exchange of this information is performed via the FSSB (optical cable).

### - Example of connection around the amplifier (Typical example)

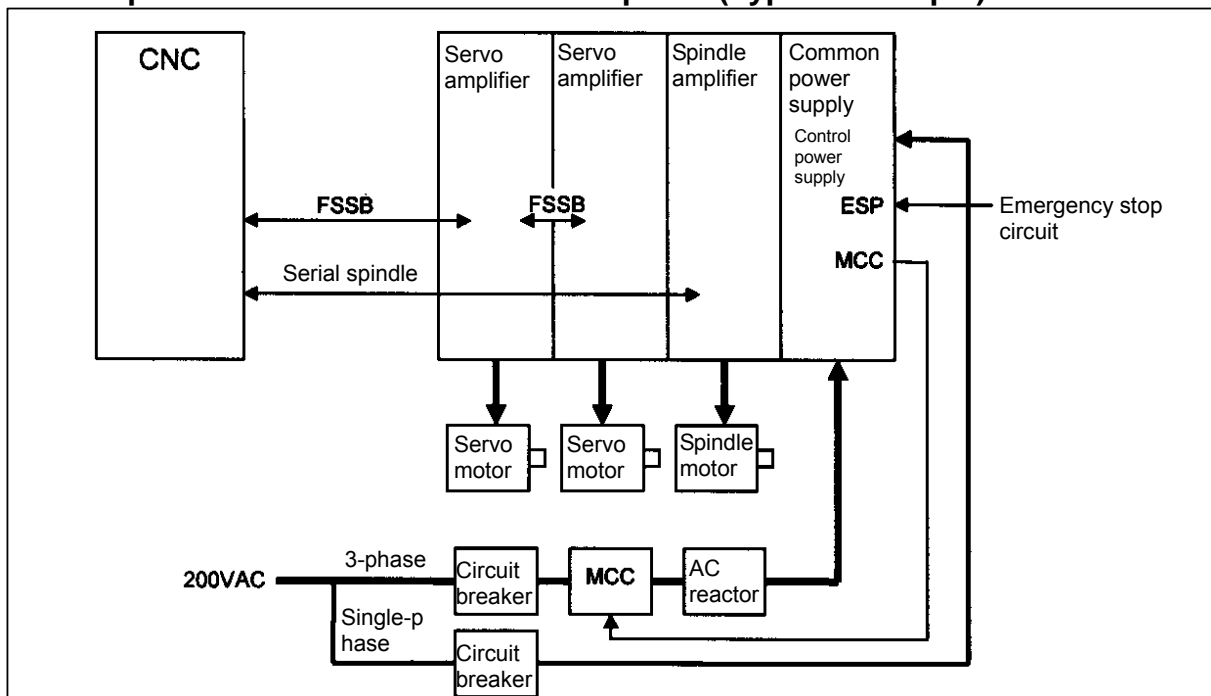

#### Check items

- Is the Common Power Supply on?
- Has an emergency stop been canceled?
- Is a terminating connector connected to the JX1B connector of the terminating amplifier?
- Is MCC on? If there is an external MCC sequence in addition to the MCC contact of the Common Power Supply, check that sequence also.
- Is the power for driving MCC supplied?
- Is the breaker on?
- Has some alarm been issued in the Common Power Supply or spindle amplifier?
- Diagnosis data No. 358, V ready-off information. (See Section, "DIAGNOSIS FUNCTION" for details.)

### - Replacing the servo amplifier

If no problem is found in the power magnetic circuit around the amplifier, replace the servo amplifier.

- **Replacing the axis control cards**

If the above action does not solve the problem, replace the axis control cards.

## 10.15 ALARM SV0404 (V READY ON)

### Causes and Countermeasures

This alarm is issued if the servo ready signal (VRDY) of a servo amplifier remains on. The servo amplifier or the axis control cards on the CNC may be defective.

- **VRDY**

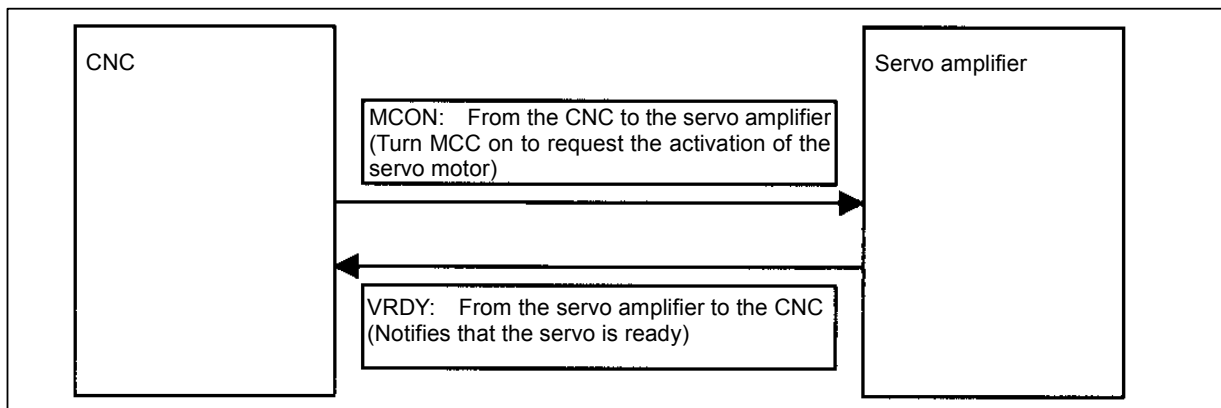

The exchange of this information is performed via the FSSB (optical cable).

This alarm is issued if VRDY remains on when the CNC turns MCON off or if VRDY turns on before the CNC turns MCON on.

- **Replacing the servo amplifier**

The servo amplifier may be defective. Replace the servo amplifier.

- **Replacing the axis control cards**

If replacing the servo amplifier does not solve the problem, replace the axis control cards.

## 10.16 ALARM SV0462 (SEND CNC DATA FAILED) ALARM SV0463 (SEND SLAVE DATA FAILED)

### Causes and Countermeasures

Alarm SV0462 is issued if a slave (servo amplifier) cannot receive correct data due to an FSSB communication error.

Alarm SV0463 is issued if the CNC cannot receive correct data due to an FSSB communication error.

If these alarms are issued, the alarm message indicates the number of the defective axis (axis name).

- **Servo amplifier or optical cable**

Any of the optical cables between the CNC control unit and the amplifier corresponding to the axis number indicated in the alarm message may be defective.

Or, any of the first amplifier to the amplifier corresponding to that axis number may be defective.

- **Axis control cards**

The axis control cards installed on the CNC may be defective.

## 10.17 ALARM SV0417 (DIGITAL SERVO SYSTEM IS ABNORMAL)

---

Digital servo parameters are abnormal.

(Digital servo parameters are set incorrectly.)

Check diagnosis data Nos.203#4, 280, and 352, detail number for invalid servo parameter setting alarm. (See Section, "DIAGNOSIS FUNCTION" for details.)

### Causes

- (1) Check bit 4 of diagnosis data No. 203 to see where the alarm was detected.
  - If bit 4 of diagnosis data No. 203 = 0:
    - A CNC detection parameter is invalid. For details, check diagnosis data No. 280.
  - If bit 4 of diagnosis data No. 203 = 1:
    - A servo detection parameter is invalid. For details, check diagnosis data No. 352.
  
- (2) If a CNC detection parameter is invalid, check diagnosis data No. 280 and the settings of the following parameters.
  - Parameter No. 2020 : Motor format number
  - Parameter No. 2022 : Motor rotation direction
  - Parameter No. 2023 : Number of pulses of velocity feedbacks
  - Parameter No. 2024 : Number of pulses of position feedback
  - Parameter No. 1023 : Servo axis number
  - Parameter No. 2084 : Flexible feed gear ratio
  - Parameter No. 2085 : Flexible feed gear ratio
  - Parameter No. 2211#6 : 2-winding motor is used.
  - Parameter No. 2211#7 : 4-winding motor is used.
  
- (3) If a servo detection parameter is invalid, check diagnosis data No. 352 to find the cause, and correct the corresponding servo parameter. Refer to the servo parameter manual for explanations about the value of diagnosis data No. 352 and how to correct the invalid parameter setting.

## 10.18 ALARM OH0700 (OVERHEAT: CONTROL UNIT)

---

### Causes and Countermeasures

This alarm is issued if the ambient temperature of the CNC control unit is abnormally high. As an installation condition, the ambient temperature of the CNC must not exceed 58°C (for LCD-mounted type) or 55°C (for stand-alone type).

#### - Ambient temperature

A temperature monitoring circuit is installed on the main board, and causes this alarm to be issued if the ambient temperature is abnormally high.

Take appropriate action to the cabinet that houses the CNC control unit so that the temperature falls within the proper temperature range (0 to 58°C (for LCD-mounted type) or 0 to 55°C (for stand-alone type)).

If it is obvious that the ambient temperature is not abnormal, the main board may be defective.

## 10.19 ALARM OH0701 (OVERHEAT: FAN MOTOR)

### Causes and Countermeasures

This alarm is issued if a fault occurs in any of the fan motors, such as the stoppage of a fan motor during the operation of the CNC.

#### - Fan motors

Fan motors are installed in the uppermost portion of the CNC control unit. Each fan motor is attached with an alarm detector circuit, which notifies the CNC of a fault such as the stoppage of the fan motor, thereby issuing this alarm.

If this alarm is issued, replace the fan motor according to "Replacing the fan motor" or "Replacing the fan unit".

## 10.20 ALARM SV5134 (FSSB: OPEN READY TIME OUT) ALARM SV5137 (FSSB: CONFIGURATION ERROR) ALARM SV5197 (FSSB: OPEN TIME OUT)

### Causes and Countermeasures

These alarms are issued due to a failure in the optical cable, axis control card, or a slave such as a servo amplifier connected to the FSSB. They are issued also if the setting of a parameter related to the FSSB is incorrect. Check diagnosis data Nos. 3510, 3511, and 3513 and change the corresponding parameter accordingly. (See Section, "DIAGNOSIS FUNCTION" for details.)

No.	Message	Description
SV5134	FSSB:OPEN READY TIME OUT	In the initialization, the FSSB could not be in an open ready state. The axis card is thought to be defective.
SV5137	FSSB:CONFIGURATION ERROR	An FSSB configuration error occurred. The connecting amplifier type is incompatible with the FSSB setting value.
SV5197	FSSB:OPEN TIME OUT	The initialization of the FSSB was completed, but it could not be opened. Or, the connection between the CNC and the amplifier is incorrect.

#### - Checking the parameter settings

Check that the FSSB-related parameters are set correctly.

#### - Power supplies of the servo amplifiers

Check the power supplies of the servo amplifiers connected to the FSSB.

#### - Replacing the axis control cards, optical cables, and servo amplifiers

Replace the axis control cards on the CNC.

Replace the optical cables and servo amplifiers connected to the FSSB, one at a time, to identify the defective item.

## 10.21 ALARM SV5136 (FSSB: NUMBER OF AMPS IS SMALL)

### Causes and Countermeasures

The number of servo amplifiers recognized by the FSSB is insufficient, compared with the number of controlled axes.

#### - FSSB setting screen

If this alarm is issued, display the amplifier setting screen from the FSSB setting screen. Only the servo amplifiers recognized on the FSSB are displayed.

#### - Optical cable or servo amplifier

The optical cable that connects together the last recognized amplifier and the next one may be defective. Or, either of the amplifiers connected together with that optical cable may be defective. Check the power supplies of the amplifiers.

#### - Power fault of a servo amplifier

This alarm may be issued if a power fault occurs in a servo amplifier. A power fault occurs if the amplifier control power supply voltage drops, if the +5 V conductor of the Pulsecoder cable is ground, or for other reasons.

#### - Axis control cards

The axis control cards installed on the CNC may be defective.

## 10.22 SERVO ALARMS

The servo alarms are listed in Appendix A. For explanations about the alarms related to servo amps and servo motors, refer to the FANUC AC SERVO MOTOR  $\alpha i$  series, AC SPINDLE MOTOR  $\alpha i$  series, and SERVO AMPLIFIER  $\alpha i$  series Maintenance Manual (B-65285EA).

If the hardware on the CNC is suspected to be defective as a result of examination, replace the axis control cards.

## 10.23 SPINDLE ALARMS

For an explanation of the following spindle alarms, refer to the FANUC AC SERVO MOTOR  $\alpha i$  series, AC SPINDLE MOTOR  $\alpha i$  series, SERVO AMPLIFIER  $\alpha i$  series Maintenance Manual (B-65285EN).

Number	Contents
SP9001 to later: Spindle_n	n-th spindle alarm (Spindle alarm display 01 or larger)

## 10.24 SYSTEM ALARMS

### 10.24.1 Overview

The FANUC 30i series makes a transition to the special processing state called the system alarm state when a state that disables the continuation of normal system operation is detected.

When the system alarm state is entered, the CNC screen display is switched and the following operations are performed:

- Servo and spindle amplifier excitation is turned off.
- Disconnection of I/O Link  $i$  or I/O Link communication



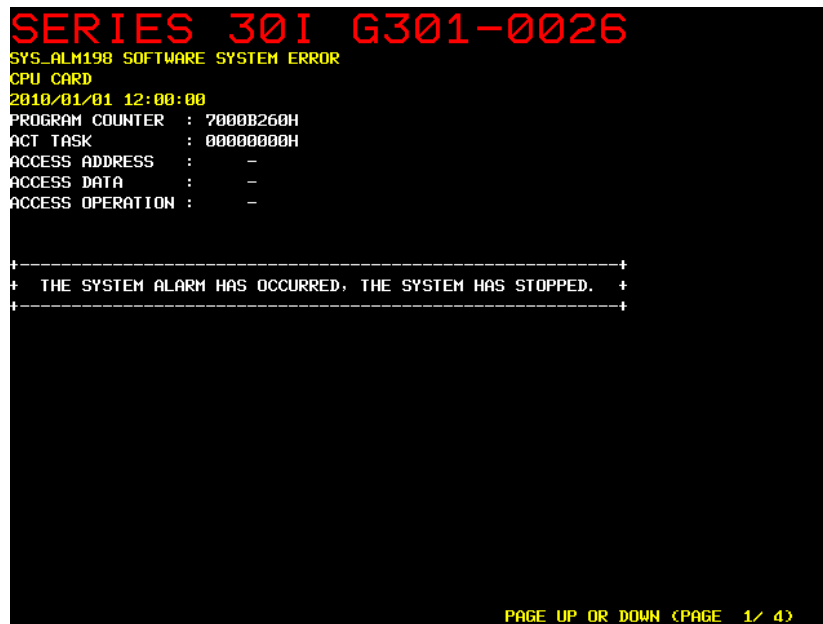

Fig. 10.24.1 (a) Example of system alarm screen

## Types of System Alarms

System alarms are classified into three types according to the following causes:

- Software causes
- Hardware causes
- Others

### - Software causes

Mainly, the CNC system software detects software errors.

Typical causes are as follows:

- Conflict in processing/data detected by the internal state monitoring software
- Access to outside of the valid data/instruction ranges
- Division by zero
- Stack overflow
- Stack underflow
- DRAM checksum error

### - Hardware causes

Mainly, hardware detects hardware errors.

Typical causes are as follows:

- Parity error (DRAM, SRAM, cache)
- Bus error
- Power supply alarm
- FSSB cable disconnection

### - Others

Moreover, system alarms are caused by the following:

- Causes detected by peripheral software
  - Servo software (such as watchdog)
  - PMC software (such as an I/O link communication error)

## 10.24.2 Operations on the System Alarm Screen

### Description of system alarm screen

When a system alarm is issued, the screen display is switched to a screen as shown below (Fig. 10.24.2 (a)).

This screen is referred to as the system alarm screen.

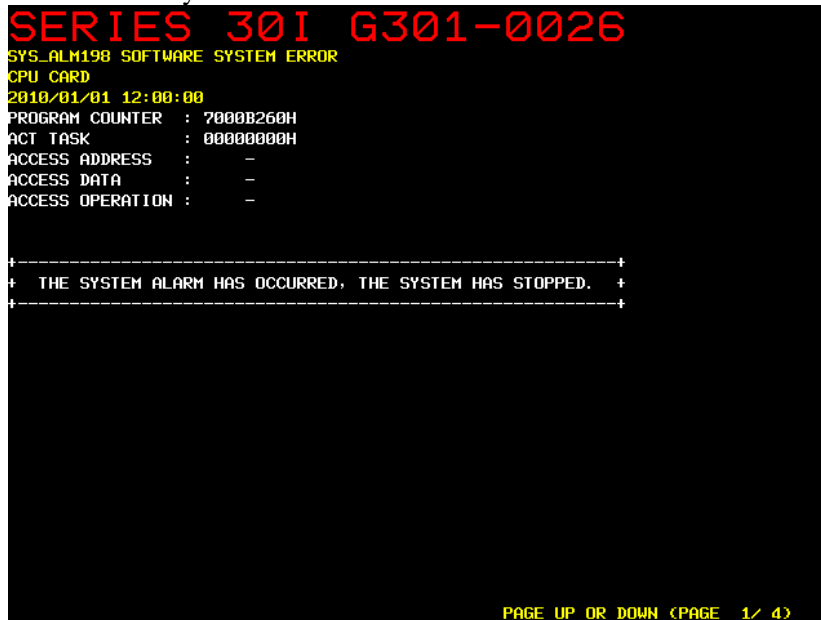

Fig. 10.24.2 (a) System alarm screen

The system alarm screen consists of several pages of information.

The following key operations are used:



Switches between pages.



Executes the IPL monitor.

### Saving of system alarm information

Various information items related to a system alarm are saved in the SRAM.

The SRAM can store information about the latest two system alarms.

If a third system alarm is issued when information about the latest two system alarms is stored, the information about the oldest system alarm is discarded, and information about the new system alarm is saved.

Saved system alarm information can be output from the IPL screen to the memory card.

### Output of system alarm information

With the FANUC Series 30*i* /31*i* /32*i*, saved system alarm information can be output from the IPL screen to the memory card.

1. Start the IPL monitor.

If the system alarm screen is displayed when a system alarm is issued, press the  key.

If the power is turned off, turn on the power while holding down "-" and ".".

2. On the IPL monitor screen, enter 5 to select "5. SYSTEM ALARM UTILITY".

```

SERIES 30I G301-0026
COPYRIGHT(C) FANUC LTD. 2010-
IPL MENU
0. END IPL
1. DUMP MEMORY
3. CLEAR FILE
4. MEMORY CARD UTILITY
5. SYSTEM ALARM UTILITY
6. FILE SRAM CHECK UTILITY
7. MACRO COMPILER UTILITY
8. SYSTEM SETTING UTILITY
?

```

3. Enter 2 to select "2. OUTPUT SYSTEM ALARM FILE".

```

SERIES 30I G301-0026
COPYRIGHT(C) FANUC LTD. 2010-
SYSTEM ALARM UTILITY MENU
0. END
1. DISPLAY SYSTEM ALARM
2. OUTPUT SYSTEM ALARM FILE
?

```

4. If the IPL monitor is executed on the system alarm screen, enter 2 to select "2. OUTPUT SYSTEM ALARM FILE FROM DRAM".  
If the power is turned off, enter 1 to select "1. OUTPUT SYSTEM ALARM FILE FROM FILE-RAM".

```

SERIES 30I G301-0026
COPYRIGHT(C) FANUC LTD. 2010-
CHECK SYSTEM LABEL : END
OUTPUT SYSTEM ALARM FILE MENU
0. END
1. OUTPUT SYSTEM ALARM FILE FROM FILE-RAM
2. OUTPUT SYSTEM ALARM FILE FROM DRAM
?

```

5. If 1 is selected in step 4, a list of saved system alarms is displayed. Enter the number of a file to be output.

```

SERIES 30I G301-0026
COPYRIGHT(C) FANUC LTD. 2010-
CHECK SYSTEM LABEL : END
OUTPUT SYSTEM ALARM FILE MENU
0. END
1. OUTPUT SYSTEM ALARM FILE FROM FILE-RAH
2. OUTPUT SYSTEM ALARM FILE FROM DRAM
? 1

SYSTEM ALARM FILE INFORMATION
0. END
1. SYS_ALM198 SOFTWARE SYSTEM ERROR
   ERROR OCCURRED AT 2010/01/01 12:00:00
2. SYS_ALM114 FSSB DISCONNECTION
   ERROR OCCURRED AT 2010/01/01 12:00:00
?

```

6. Enter the file name to output the file.

```

SERIES 30I G301-0026
COPYRIGHT(C) FANUC LTD. 2010-
CHECK SYSTEM LABEL : END
OUTPUT SYSTEM ALARM FILE MENU
0. END
1. OUTPUT SYSTEM ALARM FILE FROM FILE-RAH
2. OUTPUT SYSTEM ALARM FILE FROM DRAM
? 1

SYSTEM ALARM FILE INFORMATION
0. END
1. SYS_ALM198 SOFTWARE SYSTEM ERROR
   ERROR OCCURRED AT 2010/01/01 12:00:00
2. SYS_ALM114 FSSB DISCONNECTION
   ERROR OCCURRED AT 2010/01/01 12:00:00
? 1

MEM_CARD FILE NAME ? SYS_ALM1.TXT

```

#### NOTE

- 1 Specify the name of a file to be output to a memory card in the format of a file name (8 characters) and file extension (3 characters). Begin the file name and file extension with an alphabetic letter or number.
- 2 If the name of a file output to a memory card contains any of the characters listed below, a problem will arise when an attempt is made to read data from the file on a PC. So, do not use these characters. The period can be used only as a delimiter between the file name and file extension.  
 . " / ¥ [ ] : ; = , \* ? < > + (space character)
- 3 If the name of a file output to a memory card is any of the character strings listed below, a problem will arise when an attempt is made to read data from the file on a PC. So, do not use these character strings as a file name.  
 CON , AUX , COM1 , COM2 , COM3 , COM4 , LPT1 , LPT2 , LPT3 , PRN , NUL

## 10.24.3 System Alarms Detected by Hardware

System alarm 400 and subsequent system alarms indicate errors detected by hardware. The basic screen configuration is shown below:

```

① SERIES 30I GXXXX
② SYS_ALM401 EXTERNAL BUS INVALID ADDRESS
③ MAIN BOARD
④ 2010/04/14 17:09:53

⑤ PROGRAM COUNTER : 1000B52CH
   ACT TASK       : 01000010H
   ACCESS ADDRESS : -
   ACCESS DATA   : -
   ACCESS OPERATION : -

⑥ BUS MASTER PCB : MAIN BOARD
   +-----+
   02 MAIN BOARD 03012003 22110000 80010000 00000000 00010000 00000000
                       FFFFFFFF FFFFFFFF 68C08216 70FE0000 00000000 00000000
                       00000000 00000000 00000000 00000000 00000000

   BUS SLAVE PCB  : CPU CARD
   +-----+
   00 CPU CARD   02071004 20100000 00000000 00000000 00000000 00000000
                       FFFFFFFF FFFFFFFF 10B0FC00 CFF90001 68C30061 82160010
                       000000F0 00000000 00010000 00000000 00000000

   INFORMATION REGISTER
   +-----+
   02 MAIN BOARD 00000000 00000000 00000000 00000000

                                     PAGE UP OR DOWN (PAGE 1/8)

```

[Description of the message screen]

- (1): Device name, and series and edition of CNC system software
- (2): System alarm number and error message
- (3): Most possibly faulty component
- (4): Date and time when the error occurred
- (5): Software error and other information when the error occurred
- (6): Bus information when the error occurred

### NOTE

Item (3) indicates the most possibly faulty component. Mainly, check the component to see whether it is defective. See the Table 10.24.3 (a) for the alarm messages that may prompt you to take measures other than the replacement of a component indicated by Item (3).

Information about system alarms displayed on the screen can be output as a text file via the PCMCIA port of the LCD (or the PCMCIA port of a CNC if the CNC is a stand-alone type CNC (having PC functions)).

For the method of outputting it, see Subsection, "Operations on the System Alarm Screen".

Table 10.24.3 (a)

Message	Description	Causes	Countermeasures
SYS_ALM401 EXTERNAL BUS INVALID ADDRESS	A problem occurred on a CNC bus.	The printed circuit board may be defective or external noise may affect the bus.	It is likely that, besides the most possibly faulty component displayed, the main board and "MASTER PCB" or "SLAVE PCB" displayed on the system alarm screen may be defective. This error may also be caused by external noise. Check whether there is a noise origin around the machine and whether the machine is grounded properly.
SYS_ALM403 S-BUS TIME OUT ERROR	A problem occurred on a CNC bus.	The printed circuit board may be defective.	It is likely that, besides the most possibly faulty component displayed, the main board and "MASTER PCB" or "SLAVE PCB" displayed on the system alarm screen may be defective.
SYS_ALM404 ECC UNCORRECTABLE ERROR	A problem occurred on a CNC bus.	The printed circuit board may be defective or external noise may affect the bus.	It is likely that, besides the most possibly faulty component displayed, the main board and "MASTER PCB" or "SLAVE PCB" displayed on the system alarm screen may be defective. This error may also be caused by external noise. Check whether there is a noise origin around the machine and whether the machine is grounded properly.
SYS_ALM502 NOISE ON POWER SUPPLY	Noise or an instantaneous power failure occurred in the CNC power supply.	A power fault occurs.	Identify and remove the cause of an abnormal condition such as noise. This error may damage SRAM data.

## 10.24.4 System Alarms 114 to 160 (Alarms on the FSSB)

### Causes

An alarm was detected on the FSSB.

#### NOTE

The alarm message states the location of a faulty component. The location is indicated using the following character strings.

MAIN : Servo card or additional axis board in the CNC

AMPx : The xth servo amplifier or spindle amplifier as counted from the CNC of each line.

A 2-axis amplifier and 3-axis amplifier are each counted as one unit.

SDUx : The xth separate detector interface unit as counted from the CNC of each line

LINEx : FSSB line where an alarm arose

"/LINEx" following a message if displayed indicates the number of an optical connector on a servo control printed circuit board.

LINE1 : COP10A-1 on the servo card

LINE2 : COP10A-2 on the servo card

LINE3 : COP10A-3 on the additional axis board

Message	Description and countermeasures
SYS_ALM114 FSSB DISCONNECTION (MAIN -> AMP1) /LINEx SYS_ALM115 FSSB DISCONNECTION (MAIN -> SDU1) /LINEx SYS_ALM116 FSSB DISCONNECTION (AMPn -> AMPm) /LINEx SYS_ALM117 FSSB DISCONNECTION (AMPn -> SDU m) /LINEx SYS_ALM118 FSSB DISCONNECTION (SDU n -> AMP m) /LINEx SYS_ALM119 FSSB DISCONNECTION (SDU n -> SDU m) /LINEx	<p>&lt;Description&gt; No FSSB communication can be performed between the units stated in the parentheses.</p> <p>&lt;Countermeasures&gt; Replace the servo card, amplifier, or separate detector interface unit of interest. It is also likely that there may be a problem on an optical fiber cable between the connections of interest.</p>
SYS_ALM120 FSSB DISCONNECTION (MAIN <- AMP1) /LINEx SYS_ALM121 FSSB DISCONNECTION (MAIN <- SDU 1) /LINEx SYS_ALM122 FSSB DISCONNECTION (AMPn <- AMPm) /LINEx SYS_ALM123 FSSB DISCONNECTION (AMPn <- SDU m) /LINEx SYS_ALM124 FSSB DISCONNECTION (SDU n <- AMP m) /LINEx SYS_ALM125 FSSB DISCONNECTION (SDU n <- SDU m) /LINEx	<p>&lt;Description&gt; No FSSB communication can be performed between the units stated in the parentheses.</p> <p>&lt;Countermeasures&gt; Replace the servo card, amplifier, or separate detector interface unit of interest. It is also likely that there may be a problem on an optical fiber cable between the connections of interest.</p> <p>It is likely that there may be an abnormal condition in the power supply for the right-side unit stated in the parentheses. Check to see if there is any abnormality in the power supplied to the unit and if there is any short-circuit in the cable of the motor or encoder connected to the unit.</p>
SYS_ALM126 SERVO AMP INTERNAL DISCONNECTION (AMPn) -> /LINEx SYS_ALM127 SERVO AMP INTERNAL DISCONNECTION (AMPn) <- /LINEx	<p>&lt;Description&gt; Abnormal communication data was detected in the amplifier stated in the parentheses.</p> <p>&lt;Countermeasures&gt; Replace the amplifier of interest.</p>
SYS_ALM129 ABNORMAL POWER SUPPLY (SERVO:AMPn) /LINEx SYS_ALM130 ABNORMAL POWER SUPPLY (SERVO:SDUn) /LINEx	<p>&lt;Description&gt; An abnormal condition was detected in the power for the unit stated in the parentheses.</p> <p>&lt;Countermeasures&gt; A voltage drop was detected in the power supplied to the unit of interest. Check to see if there is any abnormality in the power supply or power supply cable and if there is a voltage drop in the input power due to surge current.</p>

Message	Description and countermeasures
SYS_ALM134 FSSB LINE DATA ERROR (AMPn) > .. > MAIN /LINEx SYS_ALM135 FSSB LINE DATA ERROR (SDUn) > .. > MAIN /LINEx	<p>&lt;Description&gt; Abnormal data was detected in the unit stated in the parentheses.</p> <p>&lt;Countermeasures&gt; Replace the unit of interest. If an alarm is issued even after the replacement, replace the slaves previous to the unit of interest in succession. If the alarm lingers, replace the servo card (or additional axis board). It is also likely that there may be a problem on an optical fiber cable between the connections of interest.</p>
SYS_ALM138 FSSB OUT OF CORRECTION (MAIN <- AMPn) /LINEx SYS_ALM139 FSSB OUT OF CORRECTION (MAIN <- SDUn) /LINEx SYS_ALM140 FSSB OUT OF CORRECTION (AMPn <- AMPm) /LINEx SYS_ALM141 FSSB OUT OF CORRECTION (AMPn <- SDUm) /LINEx SYS_ALM142 FSSB OUT OF CORRECTION (SDUn <- AMPm) /LINEx SYS_ALM143 FSSB OUT OF CORRECTION (SDUn <- SDUm) /LINEx	<p>&lt;Description&gt; A communication data error was detected between the units stated in the parentheses.</p> <p>&lt;Countermeasures&gt; Replace the right-side unit stated in the parentheses. It is also likely that there may be a problem on other unit or an optical fiber cable between the connections of interest.</p>
SYS_ALM144 FSSB OUT OF CORRECTION (MAIN -> AMPn) /LINEx SYS_ALM145 FSSB OUT OF CORRECTION (MAIN -> SDUn) /LINEx SYS_ALM146 FSSB OUT OF CORRECTION (AMPn -> AMPm) /LINEx SYS_ALM147 FSSB OUT OF CORRECTION (AMPn -> SDUm) /LINEx SYS_ALM148 FSSB OUT OF CORRECTION (SDUn -> AMPm) /LINEx SYS_ALM149 FSSB OUT OF CORRECTION (SDUn -> SDUm) /LINEx	<p>&lt;Description&gt; A communication data error was detected between the units stated in the parentheses.</p> <p>&lt;Countermeasures&gt; Replace the left-side unit stated in the parentheses. It is also likely that there may be a problem on other unit or an optical fiber cable between the connections of interest.</p>
SYS_ALM150 SLAVE DMA BUS FAILURE (AMPn ) /LINEx SYS_ALM151 SLAVE DMA BUS FAILURE (SDUn ) /LINEx SYS_ALM152 SLAVE LSI DMA BUS FAILURE (AMPn ) /LINEx SYS_ALM153 SLAVE LSI DMA BUS FAILURE (SDUn ) /LINEx SYS_ALM154 SLAVE LOCAL ERROR NO.1 (AMPn ) /LINEx SYS_ALM155 SLAVE WATCH DOG ALARM (AMPn ) /LINEx SYS_ALM156 SLAVE LOCAL ERROR NO.2 (SDUn ) /LINEx SYS_ALM157 SLAVE LOCAL ERROR NO.3 (AMPn ) /LINEx SYS_ALM158 SLAVE LOCAL ERROR NO.3 (SDUn ) /LINEx SYS_ALM159 SPINDLE RAM FAILURE (AMPn) /LINEx SYS_ALM160 SPINDLE WATCH DOG ALARM (AMPn) /LINEx	<p>&lt;Description&gt; An error was detected in a circuit in the unit stated in the parentheses.</p> <p>&lt;Countermeasures&gt; Replace the unit of interest.</p>



## 10.25 SYSTEM ALARMS RELATED TO THE PMC AND I/O Link

If a system alarm (SYS\_ALM194, 195, 196, 197) and alarm number (PCxxx) stated below are displayed, the system alarm is related to PMC, I/O Link *i*, or I/O Link. A probable cause is a faulty PMC control circuit, an abnormal condition in I/O Link communication, or the like.

### SERIES 30I GXXXX

SYS\_ALM197 EMBEDDED SOFTWARE SYSTEM ERROR

PLEASE CHECK THE FOLLOWING INFORMATION:

2010/04/18 12:00:00

EMBEDDED SOFTWARE SYSTEM ERROR: (40xx-xxxx)

PC097 LADDER CRC ERROR (DCSPMC)

-----< ERROR POSITION >-----

CPU CARD

-----

PAGE UP OR DOWN (PAGE 1 / 5)

### System alarms 197, 199 (PMC general)

These alarms are PMC system alarms. See Appendix A.2.2, “PMC System Alarm Messages” for alarm descriptions.

#### Display example

```

SERIES 30I GXXXX
SYS_ALM197 EMBEDDED SOFTWARE SYSTEM ERROR
PLEASE CHECK THE FOLLOWING INFORMATION:
2010/04/18 12:00:00
EMBEDDED SOFTWARE SYSTEM ERROR: (40xx-xxxx)
PC097 LADDER CRC ERROR (DCSPMC)

-----< ERROR POSITION >-----
CPU CARD
-----

PAGE UP OR DOWN (PAGE 1 / 5)
    
```

System alarm 197 display

```

SERIES 30I GXXXX
SYS_ALM199 NON MASK INTERRUPT
OTHER-CPU
2010/04/18 12:00:00
PROGRAM COUNTER : _____
ACT TASK       : _____
ACCESS ADDRESS : ____-____
ACCESS DATA   : ____-____
ACCESS OPERATION : ____-____

+-----+
+ THE SYSTEM ALARM HAS OCCURRED, THE SYSTEM HAS STOPPED. +
+-----+

PAGE UP OR DOWN (PAGE 1 / 5)
    
```

System alarm 199 display (page 1)

SERIES 30I GXXXX

SYS\_ALM199 NON MASK INTERRUPT  
OTHER-CPU  
2010/04/18 12:00:00

OPTION BOARD SYSTEM ERROR: (40xx-xxxx)  
PC098 PMC SOFTWARE ECC ERROR (xxxxxxxx:xx)

-----< ERROR POSITION >-----

MAIN BOARD  
-----

```

00000000 00000000 00000000 00000000 00000000 00000000 00000000 00000000
00000000 00000000 00000000 00000000 00000000
00000000 00000000 00000000 00000000 00000000 00000000 00000000 00000000
00000000 00000000 00000000 00000000 00000000 00000000 00000000 00000000
00000000 00000000 00000000 00000000 00000000 00000000 00000000 00000000
00000000 00000000 00000000 00000000 00000000 00000000 00000000 00000000

00000000 00000000 00000000 00000000 00000000 00000000 00000000 00000000
00000000 00000000 00000000 00000000 00000000 00000000 00000000 00000000
00000000 00000000 00000000 00000000 00000000 00000000 00000000 00000000
00000000 00000000 00000000 00000000 00000000 00000000 00000000 00000000
00000000 00000000 00000000 00000000 00000000 00000000 00000000 00000000

00000000 00000000 00000000 00000000 00000000 00000000 00000000 00000000

```

PAGE UP OR DOWN (PAGE 2 / 5)

System alarm 199 display (page 2)

## System alarm 196 (PMC watchdog)

This alarm is a PMC watchdog system alarm. See Appendix A.2.2, “PMC System Alarm Messages” for alarm descriptions.

### Display example

```
SERIES 30I GXXXX
```

```
SYS_ALM196 PMC WATCH DOG ALARM
```

```
MAIN BOARD
```

```
2010/04/18 12:00:00
```

```
EMBEDDED SOFTWARE SYSTEM ERROR: (40xx-xxxx)
```

```
PC073 WATCH-DOG ALARM (CNC<->PMC)
```

```
-----< ERROR POSITION >-----
```

```
MAIN BOARD
```

```
-----
```

```
PAGE UP OR DOWN (PAGE 1 / 5)
```

## System alarm 195 (related to the I/O Link)

This alarm is an I/O Link system alarm. See Appendix A.2.2, “PMC System Alarm Messages” for alarm descriptions.

### Display example

```
SERIES 30I GXXXX
```

```
SYS_ALM195 IO LINK ALARM
```

```
IO LINK
```

```
2008/11/18 12:00:00
```

```
EMBEDDED SOFTWARE SYSTEM ERROR (40XX-XXXX)
```

```
PC050 I/O LINK ER1 CH1:GR03:xx
```

```
COMMUNICATION ALARM AT CH1 : GROUP 03
```

```
-----< ERROR POSITION >-----
```

```
CH1 / GROUP03
```

```
RT=0, 0, 0, 0, 0, 0, 0, 0, 0, 0, 0, 0, 0, 0, 0
```

```
G00=00, 00, 00, 00 G01=00, 00, 00, 00
```

```
G02=00, 00, 00, 00 G03=3C, 3C, 3C, 00
```

```
G04=00, 00, 00, 00 G05=00, 00, 00, 00
```

```
G06=00, 00, 00, 00 G07=00, 00, 00, 00
```

```
G08=00, 00, 00, 00 G09=00, 00, 00, 00
```

```
G10=00, 00, 00, 00 G11=00, 00, 00, 00
```

```
G12=00, 00, 00, 00 G13=00, 00, 00, 00
```

```
G14=00, 00, 00, 00 G15=00, 00, 00, 00
```

```
PAGE UP OR DOWN (PAGE 1 / 5)
```

## System alarm 194 (related to the I/O Link *i*)

This alarm is an I/O Link *i* system alarm. See Appendix A.2.2, “PMC System Alarm Messages” for alarm descriptions.

### Display example

```
SERIES 30I GXXXX
```

```
SYS_ALM194 IO LINK I ALARM
```

```
IO LINK I
```

```
2008/11/18 12:00:00
```

```
EMBEDDED SOFTWARE SYSTEM ERROR (40XX-XXXX)
```

```
PC052 I/O LINK I
```

```
PMC LSI RAM PARITY ERROR
```

```
-----< ERROR POSITION >-----
```

```
MAIN BORAD
```

```
MA=03, FF, 00, 00, 00, 80 ME=00, 00 GE=10, 00 TOC=02 TTOC=05
```

```
RT=0, 0, 0, 0, 0, 0, 0, 0, 0, 0, 0, 0, 0, 0, 0, 0, 0, 0, 0, 0, 0, 0
```

```
PAGE UP OR DOWN (PAGE 1 / 5)
```

Master hardware failure display

SERIES 30I GXXXX

SYS\_ALM194 IO LINK I ALARM  
IO LINK I  
2008/11/18 12:00:00

EMBEDDED SOFTWARE SYSTEM ERROR (40XX-XXXX)

PC053 I/O LINK I  
SLAVE LSI RAM PARITY ERROR

-----< ERROR POSITION >-----

CH1 / UNIT3 (GROUP2) : I/O UNIT-A

MA=03, FF, 00, 00, 00, 80 ME=00, 00 GE=10, 00 TOC=02 TT0C=05  
RT=0, 0, 3, 0, 0, 0, 0, 0, 0, 0, 0, 0, 0, 0, 0, 0, 0, 0, 0, 0  
G02 RC=03 RT=05 H=00001000, 00001000, 00001000, 00000000

PAGE UP OR DOWN (PAGE 1 / 5)

Hardware failure display for the third unit (group 2) on channel 1

SERIES 30I GXXXX

SYS\_ALM194 IO LINK I ALARM  
IO LINK I  
2008/11/18 12:00:00

EMBEDDED SOFTWARE SYSTEM ERROR (40XX-XXXX)

PC058 I/O LINK I  
SLAVE LSI EXTERNAL ALARM

-----< ERROR POSITION >-----

CH1 / UNIT3 (GROUP2) : I/O UNIT-A

MA=03, FF, 00, 00, 00, 80 ME=00, 00 GE=10, 00 TOC=02 TT0C=05  
RT=0, 0, 3, 3, 0, 0, 0, 0, 0, 0, 0, 0, 0, 0, 0, 0, 0, 0, 0, 0  
G02 RC=03 RT=05 H=00001000, 00001000, 00001000, 00000000  
G03 RC=03 RT=05 H=00001000, 00001000, 00001000, 00000000

PAGE UP OR DOWN (PAGE 1 / 5)

Connection failure display for the third safety I/O unit (group 2 and 3) on channel 1

## SERIES 30I GXXXX

SYS\_ALM194 IO LINK I ALARM  
 IO LINK I  
 2008/11/18 12:00:00

EMBEDDED SOFTWARE SYSTEM ERROR (40XX-XXXX)

PC054 I/O LINK I  
 ABNORMAL POWER SUPPLY

-----&lt; ERROR POSITION &gt;-----

CH1 / UNIT3 (GROUP2) : I/O UNIT-A

MA=03, FF, 00, 00, 00, 80 ME=00, 00 GE=10, 00 TOC=02 TT0C=05  
 RT=0, 0, 3, 0, 0, 0, 0, 0, 0, 0, 0, 0, 0, 0, 0, 0, 0, 0, 0, 0  
 G02 RC=03 RT=05 H=00001000, 00001000, 00001000, 00000000

PAGE UP OR DOWN (PAGE 1 / 5)

Power failure alarm display for the third unit (group 2) on channel 1

## SERIES 30I GXXXX

SYS\_ALM194 IO LINK I ALARM  
 IO LINK I  
 2008/11/18 12:00:00

EMBEDDED SOFTWARE SYSTEM ERROR (40XX-XXXX)

PC055 I/O LINK I  
 I/O LINK I SENDING DATA FAILURE

-----&lt; ERROR POSITION &gt;-----

CH1 / UNIT2 (GROUP1) &lt;-&gt; UNIT3 (GROUP2)

UNIT2 : I/O UNIT-A  
 UNIT3 : ID=0xA5

MA=03, FF, 00, 00, 00, 80 ME=00, 00 GE=10, 00 TOC=02 TT0C=05  
 RT=3, 3, 3, 3, 0, 0, 0, 0, 0, 0, 0, 0, 0, 0, 0, 0, 0, 0, 0, 0  
 G00 RC=03 RT=05 H=00001000, 00001000, 00001000, 00000000  
 G01 RC=04 RT=05 H=00011000, 00011000, 00011000, 00011000  
 G02 RC=03 RT=05 H=00111000, 00111000, 00111000, 00000000  
 G03 RC=03 RT=05 H=00110000, 00110000, 00110000, 00000000

PAGE UP OR DOWN (PAGE 1 / 5)

Alarm display for communication between the second unit (group 1) and third unit (group 2) on channel 1



**SERIES 30I GXXXX**

SYS\_ALM194 IO LINK I ALARM  
 IO LINK I  
 2008/11/18 12:00:00

EMBEDDED SOFTWARE SYSTEM ERROR (40XX-XXXX)

PC056 I/O LINK I  
 I/O LINK I DISCONNECTION

-----< ERROR POSITION >-----

CH1 / UNIT2 (GROUP1) <-> UNIT3 (GROUP2)  
 UNIT2 : I/O UNIT-A  
 UNIT3 : ID=0xA5

MA=03, FF, 00, 00, 00, 80 ME=00, 00 GE=10, 00 TOC=02 TT0C=05  
 RT=3, 3, 3, 3, 0, 0, 0, 0, 0, 0, 0, 0, 0, 0, 0, 0, 0, 0, 0, 0, 0, 0  
 G00 RC=03 RT=05 H=00001000, 00001000, 00001000, 00000000  
 G01 RC=04 RT=05 H=00011000, 00011000, 00011000, 00011000  
 G02 RC=03 RT=05 H=00111000, 00111000, 00111000, 00000000  
 G03 RC=03 RT=05 H=00110000, 00110000, 00110000, 00000000

PAGE UP OR DOWN (PAGE 1 / 5)

**Alarm display for a connection failure between the second unit (group 1) and third unit (group 2) on channel 1**

**SERIES 30I GXXXX**

SYS\_ALM194 IO LINK I ALARM  
 IO LINK I  
 2008/11/18 12:00:00

EMBEDDED SOFTWARE SYSTEM ERROR (40XX-XXXX)

PC057 I/O LINK I  
 SAFETY I/O ALARM

-----< ERROR POSITION >-----

CH1 / UNIT2 (GROUP1) : I/O UNIT-A

MA=03, FF, 00, 00, 00, 80 ME=00, 00 GE=10, 00 TOC=02 TT0C=05  
 RT=0, 3, 0  
 DA=00, 02, 00, 10 DOC=00, 00, 00, 02 DIC=00, 00, 00, 03  
 DST=00, 00, 01, 00, 03, 03  
 G01 RC=04 RT=05 H=00011000, 00011000, 00011000, 00011000

PAGE UP OR DOWN (PAGE 1 / 5)

**DCSPMC alarm display for the second unit (group 1) on channel 1**

## 10.26 LEDS ON UNITS SUPPORTING I/O LINK *i*

### 10.26.1 Meanings of LEDs on units supporting I/O Link *i*

The standard I/O Link *i* incorporates three LEDs, “LINK” (green), “ALM” (red), and “FUSE” (red) for each unit separately. These LEDs indicate the states of the units.

The following table lists the ON/OFF states of the LEDs and their meanings.

LED ON/OFF state	ON and OFF duration
Steadily OFF	
Steadily ON	
Blink (1:1)	ON = approx. 0.5 sec, OFF = approx. 0.5 sec
Blink (3:1)	ON = approx. 1.5 sec, OFF = approx. 0.5 sec
Blink (1:3)	ON = approx. 0.5 sec, OFF = approx. 1.5 sec
Blink (1:1 at high speed)	ON = approx. 0.25 sec, OFF = approx. 0.25 sec

#### LED 「LINK」 (green)

The “LINK” (green) LED indicates the state of communication. The following table lists the meanings of LED states.

Operation mode	LED state	Meaning	Fault location and action
Common	OFF	Power OFF	
	ON	Power ON (before communication start)	
	Blink (1:1 at high speed)	Communication at halt	Communication is at halt because of an alarm. Identify the cause according to the states of the red LED stated below or information displayed on the CNC screen.
I/O Link	Blink (1:3)	Communication in progress	
I/O Link <i>i</i>	Blink (1:1)	Communication in progress	
	Blink (3:1)	Communication in progress (Dual check safety in use)	

デュアル・チェック・セーフティ使用 -> 「Dual check safety in use」と訳しました。

**LED 「ALM」 (red)**

The “ALM” (red) LED indicates an alarm in the unit of interest or a unit subsequent to it. The following table lists the meanings of LED states.

Operation mode	LED state	Meaning	Fault location and action
Common	OFF	Normal state or power OFF	
I/O Link	ON	Alarm	It is likely that the hardware may be defective. Replace the unit.
I/O Link <i>i</i>	ON	Alarm	It is likely that the hardware may be defective. Replace the unit.
	Blink (1:1)	Broken wire between the unit of interest and a unit subsequent to it	Check for a defective cable or a poor cable connection between JD1A on the unit of interest and JD1B on a unit subsequent to that unit. Alternatively, it is likely that there may be noise. Check to see if there is noise around the cable.
	Blink (3:1)	Power failure (including instantaneous power failure) in a unit subsequent to the unit of interest	Identify and remove the cause of a power failure in a unit subsequent to the unit of interest.
	Blink (1:3)	Status alarm	A status alarm, such as a DO ground fault, has occurred. Identify and remove the cause of the alarm.

**LED 「FUSE」 (red)**

The “FUSE” (red) LED indicates whether there is a blown fuse. The following table lists the meanings of LED states.

Operation mode	LED state	Meaning	Fault location and action
Common	OFF	Fuse normal or power OFF	
	ON	Blown fuse	Replace the fuse.

### 10.26.2 Unit's LED on I/O Link *i*

The following shows the ON/OFF state of the LED for each unit on I/O Link *i* and the state of the unit inferred from the ON/OFF state. The ON/OFF state of each LED is represented using the symbols in the following table.

ALM	LINK	FUSE
■	■	■

□	Steadily OFF	
■	Steadily ON	
□	Blink (1:1)	ON = approx. 0.5 sec, OFF = approx. 0.5 sec
□	Blink (3:1)	ON = approx. 1.5 sec, OFF = approx. 0.5 sec
▲	Blink (1:3)	ON = approx. 0.5 sec, OFF = approx. 1.5 sec
□	Blink (1:1 at high speed)	ON = approx. 0.25 sec, OFF = approx. 0.25 sec

- (1) If all LEDs for each unit are steadily OFF:  
No power is supplied to the units.

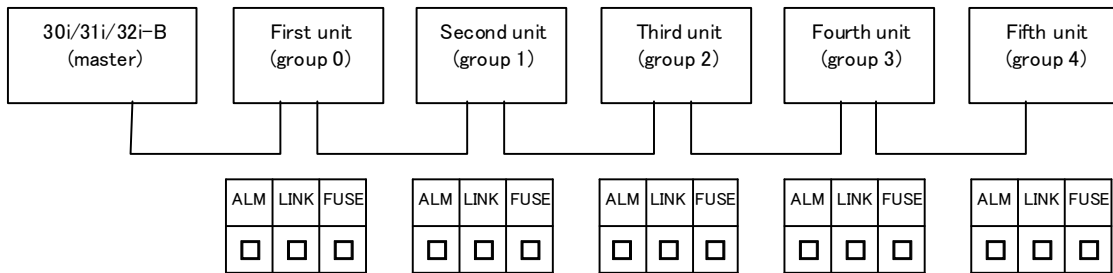

- (2) If "LINK" for each unit is steadily ON:  
Power is being supplied to each unit but I/O Link *i* has not begun communication.

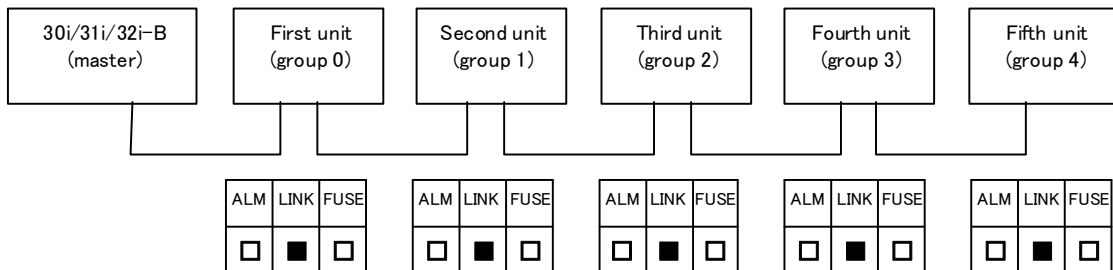

- (3) If “LINK” for each unit is blinking at an ON:OFF ratio of 1:1 or 3:1:  
 I/O Link *i* is normally communicating with the units. For a unit being used as dual check safety, “LINK” blinks at an ON:OFF ratio of 3:1.

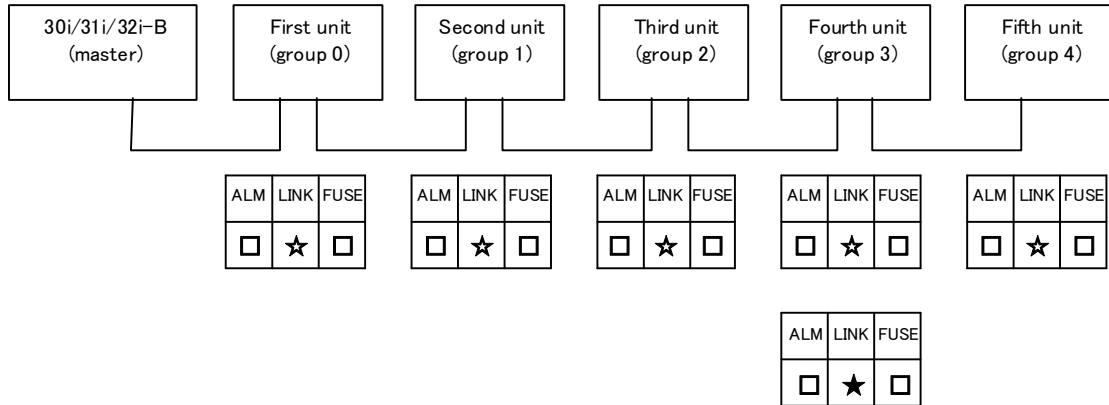

The state of a unit using dual check safety

- (4) If “ALM” for any unit is blinking at an ON:OFF ratio of 1:1:  
 It is likely that there may be a disconnected communication path (due to a defective communication cable or a poor cable connection) or an abnormal condition (due to noise) between the unit of interest and the unit immediately subsequent to that unit.  
 In this case, “LINK” for each unit previous to the point of disconnection blinks at 1:1 (high speed) and “LINK” for each unit subsequent to the point of disconnection is ON.  
 Check for a defective cable, a poor cable connection, and surrounding noise between JD1A on the unit for which “ALM” is blinking at 1:1 and JD1B on the unit immediately subsequent to that unit.

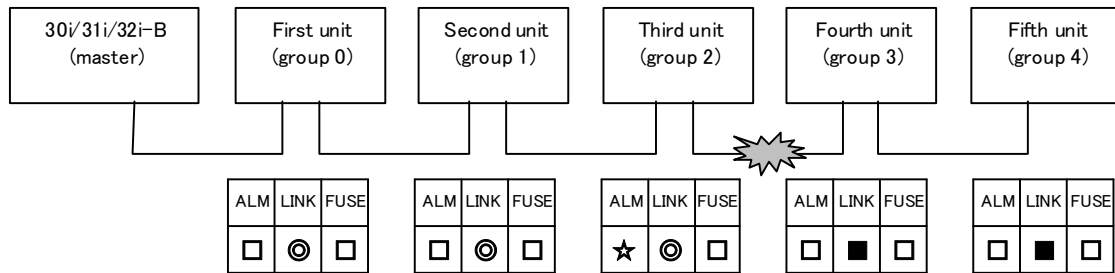

- (5) If “ALM” for any unit is blinking at an ON:OFF ratio of 3:1:  
 (i) If all the LEDs for the unit immediately subsequent to the unit for which “ALM” is blinking at 3:1 are OFF:  
 It is likely that there may be an abnormal voltage in the unit for which all the LEDs are OFF.  
 In this case, “LINK” for each unit previous to the unit having an abnormal voltage blinks at 1:1 (high speed) and “LINK” for each unit subsequent to that unit is ON.  
 For units for which all the LEDs are OFF, check that their voltage are normal.

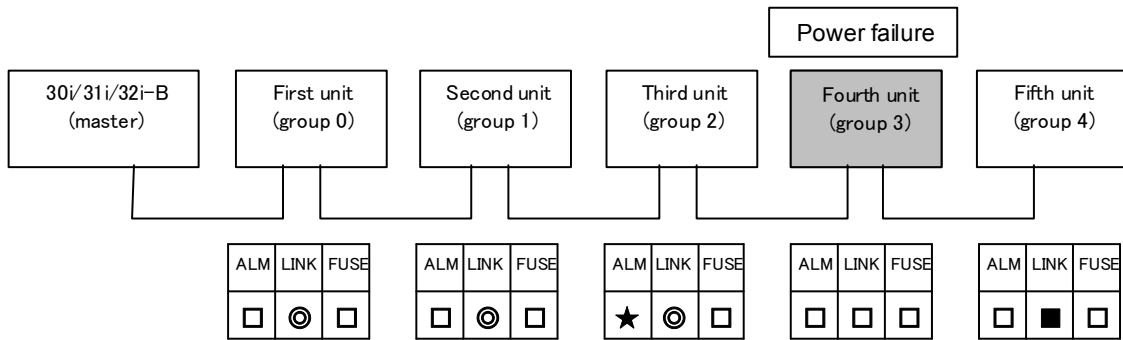

- (ii) If “LINK” for the unit immediately subsequent to the unit for which “ALM” is blinking at 3:1 is ON:  
 It is likely that an instantaneous power failure may have occurred in the unit immediately subsequent to the unit for which “ALM” is blinking at 3:1.  
 In this case, “LINK” for each unit previous to the unit where the instantaneous power failure may have occurred blinks at 1:1 (high speed) and “LINK” for the unit where the instantaneous power failure may have occurred and each unit subsequent to that unit is ON.  
 For the unit immediately subsequent to the unit for which “ALM” is blinking at 3:1, check for any instantaneous power failure.

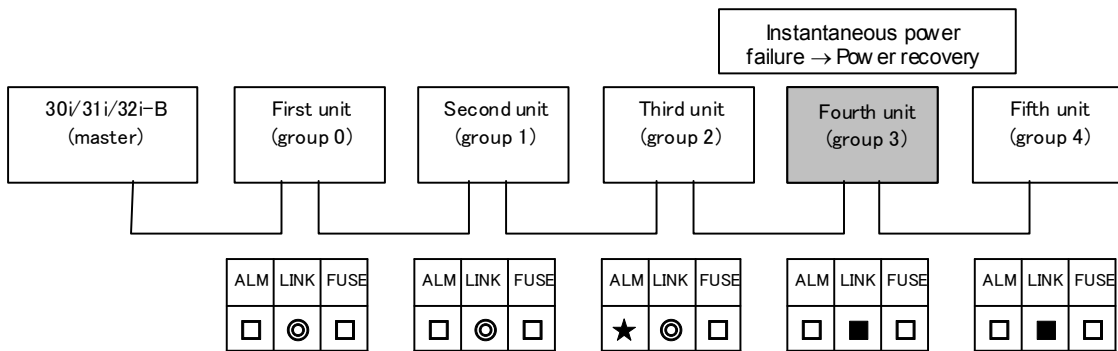

- (iii) If “FUSE” for the unit immediately subsequent to the unit for which “ALM” is blinking at 3:1 is ON:  
 It is likely that a fuse may have blown in the unit for which “FUSE” is ON.  
 In this case, “LINK” for each unit previous to the unit having a blown fuse blinks at 1:1 (high speed) and “LINK” for each unit subsequent to that unit is ON.  
 Replace the fuse for the unit for which “FUSE” is ON. See Chapter 4 for explanations about how to replace the fuse.

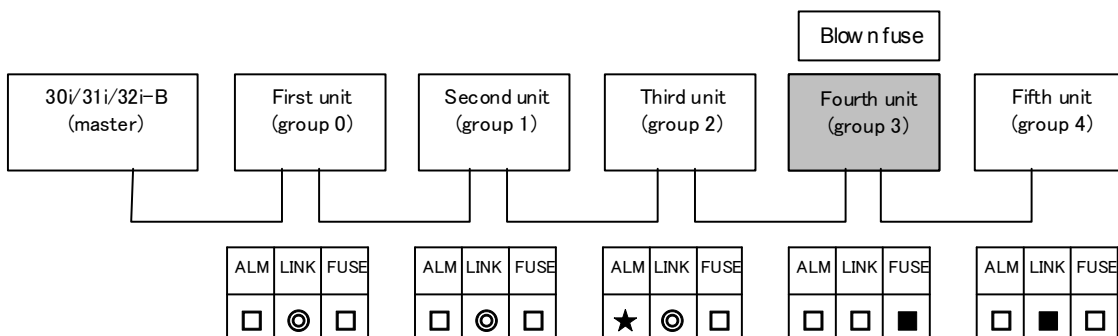

(6) If “LINK” is blinking at 1:1 (high speed) for all units:

(i) If “ALM” for any unit is ON:

It is likely that there may be an alarm condition in the unit for which “ALM” is ON. Replace the unit of interest, because its hardware may be defective.

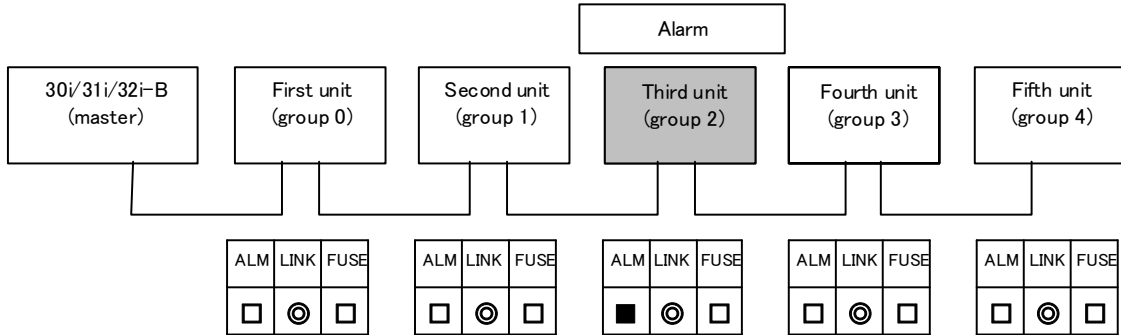

(ii) If “ALM” is OFF for all units:

It is likely that there may be an abnormal condition due to noise or the master may have an abnormal condition. Check also alarms displayed on the screen.

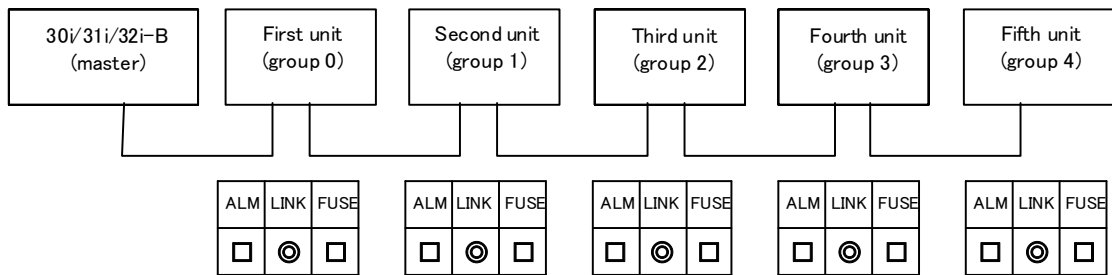

(7) If “ALM” for any unit is blinking at 1:3:

It is likely that there may be a status alarm for the unit for which “ALM” is blinking at 1:3.

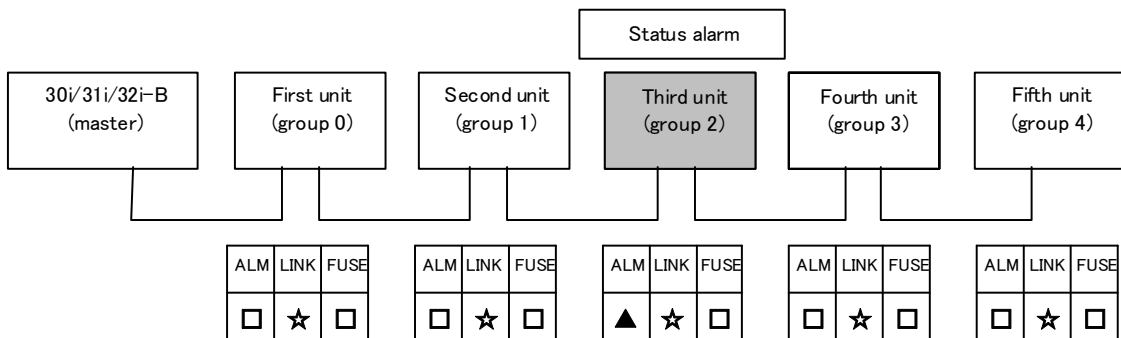

**NOTE**

Status alarms indicate a unit’s abnormal conditions, such as DO ground fault and DOCOM failure. For details, see Subsection 4.2.1.

### 10.26.3 Unit's LED on I/O Link

The I/O Link-only units incorporate no “LINK” (green), “ALM” (red), or “FUSE” (red) LED. Explained below are the meanings of the LEDs for units supporting I/O Link *i* when they communicate using I/O Link.

- (1) If all LEDs for each unit are steadily OFF:  
No power is supplied to the units.

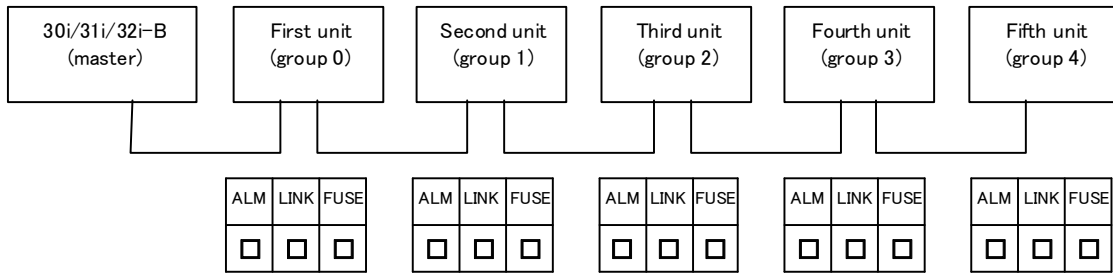

- (2) If “LINK” for each unit is steadily ON:  
Power is being supplied to each unit but I/O Link has not begun communication.

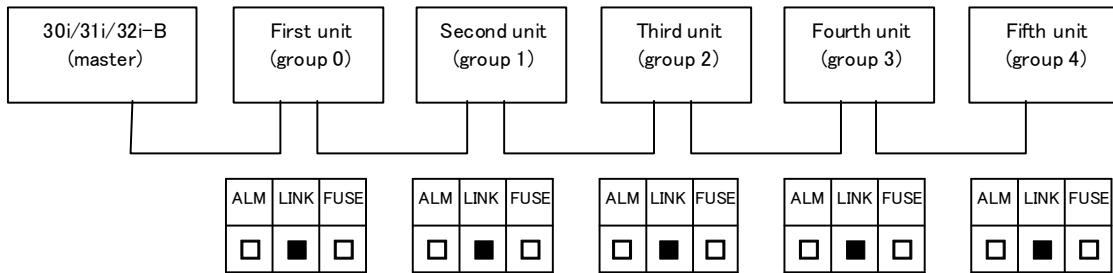

- (3) If “LINK” for each unit is blinking at an ON:OFF ratio of 1:3:  
I/O Link is normally communicating with the units.

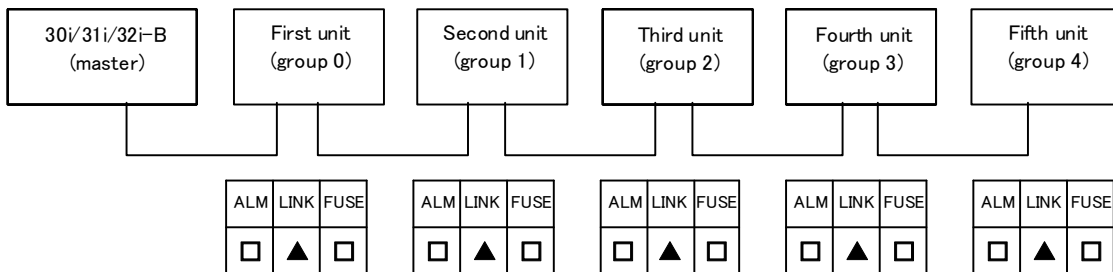



- (4) If all LEDs for any unit are OFF:  
 It is likely that a power failure may have occurred in the unit for which all LEDs are OFF.  
 In this case, “LINK” for each unit other than the unit of interest blinks at 1:1 (high speed).  
 Check to see if the power supply voltage for the unit of interest is normal.

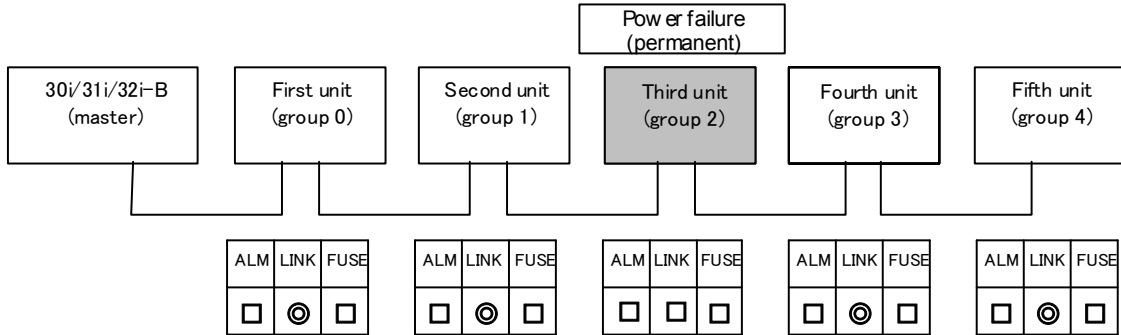

- (5) If “LINK” for any unit is ON and “LINK” for each of the other units is blinking at 1:1 (high speed):  
 It is likely that an instantaneous power failure may have occurred in the unit for which “LINK” is ON.  
 Check to see if an instantaneous power failure has occurred in the unit of interest.

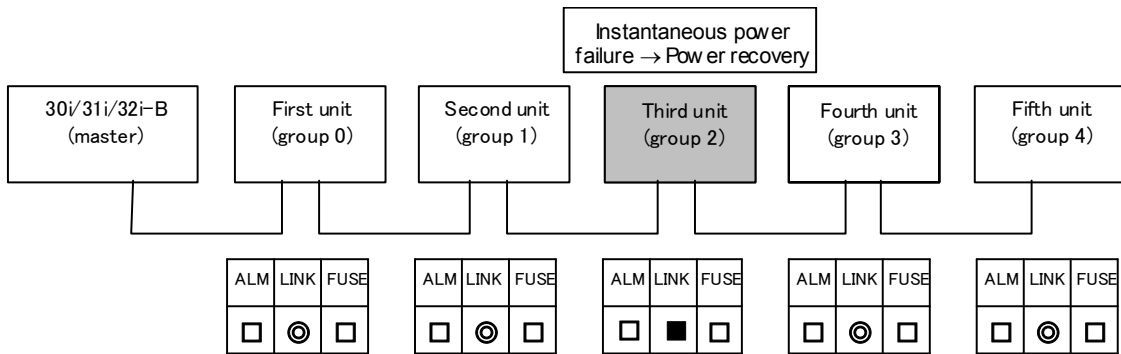

- (6) If “LINK” for each unit is blinking at 1:1 (high speed):  
 (i) If “ALM” for any unit is ON:  
 It is likely that there may be an alarm condition in the unit for which “ALM” is ON. Replace the unit of interest, because its hardware may be defective.

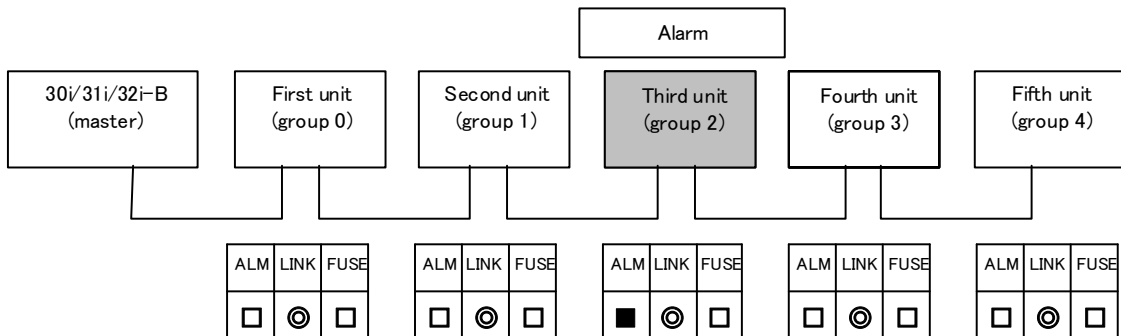

(ii) If “ALM” is OFF for all units:

It is likely that there may be a broken cable, an abnormal condition due to noise, or a failure in the master. Check also alarms displayed on the screen.

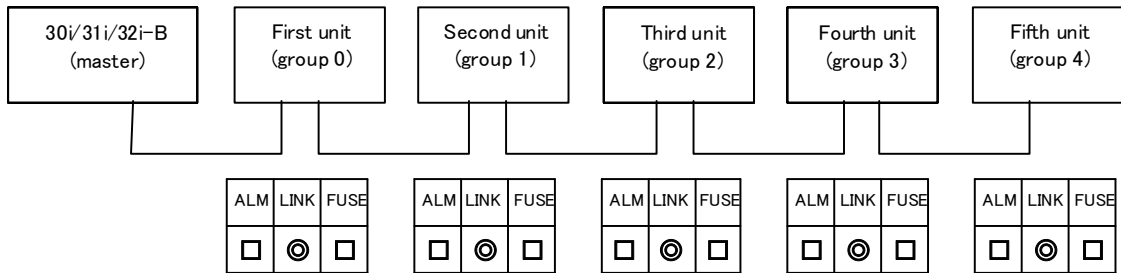

# 11 MOTOR/DETECTOR/AMPLIFIER PREVENTIVE MAINTENANCE

This chapter contains the basic information about the preventive maintenance of motors, detectors, and amplifiers.

11.1	LIST OF MANUALS RELATED TO MOTORS AND AMPLIFIERS.....	594
11.2	PREVENTIVE MAINTENANCE OF MOTORS AND DETECTORS.....	595
11.2.1	Warnings, Cautions, and Notes on Preventive Maintenance of Motors and Detectors.....	595
11.2.2	Preventive Maintenance of a Motor (Common to All Models) .....	597
11.2.2.1	Main inspection items .....	597
11.2.2.2	Periodic cleaning of a motor .....	599
11.2.2.3	Notes on motor cleaning .....	600
11.2.2.4	Notes on the cutting fluid (informational) .....	600
11.2.3	Preventive Maintenance of a Built-in Spindle Motor and Spindle Unit .....	600
11.2.3.1	Routine inspection of the FANUC-NSK spindle unit.....	601
11.2.3.2	Maintenance of the FANUC-NSK spindle unit .....	601
11.2.3.3	Test run of the FANUC-NSK spindle unit .....	602
11.2.3.4	Storage method of the FANUC-NSK spindle unit.....	602
11.2.4	Preventive Maintenance of a Linear Motor.....	602
11.2.4.1	Appearance inspection of the linear motor (magnet plate) .....	602
11.2.5	Maintenance of a Detector .....	603
11.2.5.1	Alarms for built-in detectors ( $\alpha i$ and $\beta i$ Pulsecoders) and troubleshooting actions .....	603
11.2.5.2	Alarms for separate detectors and troubleshooting actions .....	604
11.2.5.3	Detailed troubleshooting methods .....	604
11.2.5.4	Maintenance of $\beta i S$ motor Pulsecoders .....	606
11.3	PREVENTIVE MAINTENANCE OF SERVO AMPLIFIERS .....	607
11.3.1	Warnings, Cautions, and Notes on Preventive Maintenance of Servo Amplifiers.....	607
11.3.2	Preventive Maintenance of a Servo Amplifier .....	610
11.3.3	Maintenance of a Servo Amplifier .....	611
11.3.3.1	Display of the servo amplifier operation status .....	611
11.3.3.2	Replacement of a fan motor .....	613

# 11.1 LIST OF MANUALS RELATED TO MOTORS AND AMPLIFIERS

Details of individual motors and amplifiers are described in the manuals listed in the table below. Before performing periodic inspection or any other maintenance work, consult with the machine tool builder and, if necessary, obtain the latest version of the corresponding manual shown in the list. The information about the specifications of each device, such as the weight and winding resistance value, is given in the relevant "DESCRIPTIONS" manual.

Manual name	Type of manual	Specification number
FANUC AC SERVO MOTOR $\alpha i$ series	DESCRIPTIONS	B-65262EN
FANUC AC SERVO MOTOR $\beta i s$ series	DESCRIPTIONS	B-65302EN
FANUC SYNCHRONOUS BUILT-IN SERVO MOTOR $D i S$ series	DESCRIPTIONS	B-65332EN
FANUC LINEAR MOTOR $L i S$ series	DESCRIPTIONS	B-65382EN
FANUC AC SPINDLE MOTOR $\alpha i$ series	DESCRIPTIONS	B-65272EN
FANUC AC SPINDLE MOTOR $\beta i$ series	DESCRIPTIONS	B-65312EN
FANUC BUILT-IN SPINDLE MOTOR $B i l$ series	DESCRIPTIONS	B-65292EN
FANUC SYNCHRONOUS BUILT-IN SPINDLE MOTOR $B i S$ series	DESCRIPTIONS	B-65342EN
FANUC - NSK SPINDLE UNIT series	DESCRIPTIONS	B-65352EN
FANUC SERVO AMPLIFIER $\alpha i$ series	DESCRIPTIONS	B-65282EN
FANUC SERVO AMPLIFIER $\beta i$ series	DESCRIPTIONS	B-65322EN
FANUC AC SERVO MOTOR $\alpha i$ series FANUC AC SERVO MOTOR $\beta i$ series FANUC LINEAR MOTOR $L i S$ series FANUC SYNCHRONOUS BUILT-IN SERVO MOTOR $D i S$ series	PARAMETER MANUAL	B-65270EN
FANUC AC SPINDLE MOTOR $\alpha i / \beta i$ series BUILT-IN SPINDLE MOTOR $B i$ series	PARAMETER MANUAL	B-65280EN
FANUC AC SERVO MOTOR $\alpha i s / \alpha i$ series AC SPINDLE MOTOR $\alpha i$ series SERVO AMPLIFIER $\alpha i$ series	MAINTENANCE MANUAL	B-65285EN
FANUC AC SERVO MOTOR $\beta i s$ series AC SPINDLE MOTOR $\beta i$ series SERVO AMPLIFIER $\beta i$ series	MAINTENANCE MANUAL	B-65325EN
FANUC SERVO AMPLIFIER $\beta i$ series	MAINTENANCE MANUAL	B-65395EN
FANUC SERVO GUIDE	OPERATOR'S MANUAL	B-65404EN
FANUC AC SERVO MOTOR $\alpha i s / \alpha i / \beta i s$ series	SERVO TUNING PROCEDURE (BASIC)	B-65264EN

## 11.2 PREVENTIVE MAINTENANCE OF MOTORS AND DETECTORS

---

### 11.2.1 Warnings, Cautions, and Notes on Preventive Maintenance of Motors and Detectors

---

This subsection contains the safety precautions for motor and detector preventive maintenance, which are classified into "warnings", "cautions", and "notes" according to their bearing on safety. Make sure that you understand and comply with these precautions when carrying out the maintenance work.

#### **WARNING**

- **Make sure that you are safely dressed and have a safe working environment when performing preventive maintenance for a motor.**
  - Be dressed safely, e.g. by wearing gloves and safety shoes, to protect against injury due to an edge or protrusion and electric shock.
  - Have the work done by more than one person, where possible, so that immediate action can be taken if an accident occurs when handling a motor.
  - A motor is heavy. When moving it, use a crane or other appropriate equipment to protect against injury. For information about the weight of the motor, refer to its DESCRIPTIONS manual (shown earlier).
  - Clothes or fingers can be caught in a rotating motor or come into contact with a moving part of it. Standing in the direction of motor rotation (direction of motion) can pose a risk of injury. Before rotating a motor, check that there is no object that is thrown away by motor rotation.
  
- **Be careful about electric shock, fire, and other accidents.**
  - Do not handle a motor with a wet hand.
  - To prevent electric shock, make sure that no conductive object, such as a terminal, is exposed when the motor is powered on.
  - Before touching a motor or any surrounding part, check that the power is shut off and take appropriate safety precautions.
  - High voltage remains across power line terminals of a motor even after the power is shut off (for at least five minutes). Do not touch a motor in such a condition or connect it to other equipment.
  - A loose or disconnected terminal, short-circuited terminals, or a terminal connected to the ground can cause overheating, spark, fire, or damage to the motor. Take appropriate precautions to prevent these accidents.
  - When placed near any inflammable object or material, a motor can be ignited, catch fire, or explode. Avoid placing it near such object or material.
  
- **Do not disassemble or modify a motor.**

Motors such as linear motors, synchronous built-in servo motors, and synchronous built-in spindle motors contain very strong magnets. If electronic medical apparatus comes near, these motors can cause the apparatus to malfunction, potentially putting the user's life in danger. Also, disassembling or modifying a motor can cause a failure, regardless of the type of motor. Do not disassemble or modify a motor in any way not specified by FANUC.

**CAUTION**

- **Ensure that the specified cooling conditions are met.**  
If the specified cooling conditions are not met (the motor is insufficiently or excessively cooled), the motor can fail. Problems that can cause a motor failure, such as liquid piping clog, leakage, and fan motor trouble, should be eliminated through periodic inspection. Do not drive the motor when the cooling system is in an abnormal condition.
- **Do not change the system configuration.**  
Do not change the configuration of the system when it is running normally. Doing so can cause an accident or failure. If you disconnect a cable for maintenance or some other purpose, take an appropriate measure, such as putting a mark on it, to ensure you can restore the original state.
- **Use the tapped holes of a motor only to move the motor.**  
Do not use the tapped holes of a motor to lift or move any other object along with the motor. Doing so can damage the motor. Depending on the type of motor, the place and direction in which the motor can be lifted may be predetermined. For details, refer to the DESCRIPTIONS manual of the motor (shown earlier).
- **Do not touch a motor when it is running or immediately after it stops.**  
A motor may get hot when it is running. Do not touch the motor before it gets cool enough. Otherwise, you may get burned.

**NOTE**

- **Do not remove a nameplate from a motor.**  
The nameplate is used to identify the motor during maintenance work. If a nameplate comes off, be careful not to lose it.
- **Do not step or sit on a motor, and avoid applying shock to a motor.**  
Any of these acts can deform or break the motor or affect its component, crippling the normal motor operation. Do not put a motor on top of another motor.
- **Comply with the specified conditions when conducting an electric test (winding resistance test, insulation resistance test, etc.) for a motor or other device or supplying power.**
  - Conduct an electric test according to the specified method. Conducting such a test by any method that is not specified can damage the motor.
  - Do not conduct a dielectric strength test or insulation test for a Pulsecoder or other detector, or do not apply a commercial power source voltage. Doing so can destroy the internal elements.
- **Perform preventive maintenance (inspection of the external appearance, measurement of winding resistance, insulation resistance, etc.) and cleaning on a regular basis.**  
To use a motor safely throughout its entire service life, perform preventive maintenance and cleaning on a regular basis. Be careful, however, because excessively severe inspection (dielectric strength test, etc.) can damage its windings. For information about winding resistance values, refer to the DESCRIPTIONS manual of the motor (its specification number is shown in this manual). Information about insulation resistance is given later in this manual.

**NOTE**

- This manual is focused on the preventive maintenance work to be performed for a single FANUC motor or detector alone. The information contained herein may not apply depending on the type or configuration of the machine. When reading this manual, refer to the manual of the machine as well. If you have any questions or doubts, do not act on your own; please contact the machine tool builder or FANUC.
- For detailed information about a motor, see the manual list shown earlier and, if necessary, obtain the latest version of the corresponding manual.

**11.2.2 Preventive Maintenance of a Motor (Common to All Models)**

This subsection describes the common preventive maintenance items to be handled regardless of the model of the motor. For the items specific to a particular motor model, see one of the subsequent subsections that pertains to that particular motor model.

**⚠ CAUTION**

- The preventive maintenance method differs from machine to machine in many respects. Depending on the machine in use, it may be difficult for the user to perform periodic inspection or cleaning. If you are not sure about anything as to preventive maintenance, consult with the machine tool builder and ensure that you can perform periodic inspection and cleaning.
- The machine should be used within the scope of specification defined by the machine tool builder. Using the machine in any way that is outside the specified scope can reduce the motor's service life or cause a failure.

**11.2.2.1 Main inspection items**

The following table summarizes the main inspection items for a motor. If any of these items **is found to be abnormal, stop the use of the machine immediately and fix the abnormal part** by repairing or replacing it. At the same time, **identify and remove the cause and take a measure to prevent its recurrence**. If it is difficult to take a preventive measure or to prevent its recurrence, consult with the machine tool builder or FANUC.

Appearance of the motor	Crack or deformation	<ul style="list-style-type: none"> <li>- Check the motor for any scar, crack, deformation, bulge, etc.</li> <li>- If the interior of the motor is visible or there is interference with a peripheral component, it is imperative to replace the motor or the peripheral component.</li> <li>- A light peel-off or scar of the surface may be repairable; consult with FANUC.</li> </ul>
	Wet or dirty part	<ul style="list-style-type: none"> <li>- If you find any wet or dirty part, clean it immediately.</li> <li>- A preventive measure is needed if the part in question remains wet continually due to cutting fluid or dew condensation.</li> </ul>
Operating conditions	Temperature, humidity, etc.	<ul style="list-style-type: none"> <li>- Comply with the operating conditions of the machine. For details of the operating conditions of a specific motor, refer to the corresponding DESCRIPTIONS manual. Generally, the ambient temperature should be 0°C to 40°C (or 30°C for a spindle unit) and dew condensation is not allowed. In a place subject to severe vibration, the components of the motor may be broken.</li> </ul>

Connection state	Cable	<ul style="list-style-type: none"> <li>- Check for any cable sheath damage, exposed conductor, damaged conduit or cable bearing, abnormal bending, loose terminal, etc.</li> <li>- If there is any trace of fluid flowing, the fluid may have entered the inside of the motor or connector. It is necessary to make a check and take a measure to prevent recurrence.</li> </ul>
	Connector/terminal	<ul style="list-style-type: none"> <li>- Check for any cracked, exposed, loose, or removed terminal or connector, etc.</li> <li>- Fluid causes a failure; be sure to remove fluid.</li> <li>- A scarred or damaged connector or terminal needs to be replaced. In the case of a resin molded motor, such as a linear motor, the motor needs to be replaced.</li> </ul>
Operation of the motor	Noise/vibration	<ul style="list-style-type: none"> <li>- Check for any abnormal noise or vibration not only when the motor is running (the spindle is rotating) but also when it is stopped.</li> <li>- Abnormal noise heard when the motor is rotating indicates an abnormality of the bearing or a failure inside the motor.</li> </ul>
	Movement	<ul style="list-style-type: none"> <li>- Check that the motor operates normally and smoothly.</li> <li>- If the circuit breaker trips at the same time the motor starts to operate, it indicates abnormal motor windings.</li> </ul>
	Heat	<p>Check whether the motor does not overheat during the normal operation cycle.</p> <p>Note: While the motor is running or immediately after it is stopped, the motor surface may become very hot. Instead of touching the motor directly by hand, use a thermolabel, surface thermometer, etc.</p>
Electric characteristics of the motor	Winding resistance	<p>If the resistance value exceeds the specified range, the motor needs to be replaced.</p> <p>Note: When conducting winding resistance measurement, disconnect the motor from the amplifier and measure the resistance at the power line or connector closest to the motor.</p>
	Insulation resistance	<p>For the measuring method and judgment criteria, see the table that follows.</p>
Cooling fan (for a model with a fan motor)	Noise/vibration	<ul style="list-style-type: none"> <li>- Check that the fan blows air normally without causing abnormal noise or vibration.</li> <li>- If abnormal noise is heard even when the motor is stopped, it indicates a fan motor failure.</li> </ul>
	Movement	<ul style="list-style-type: none"> <li>- If the power is on and if the fan does not operate or the fan blades cannot be moved even manually, or if the fan blades are rotating but no cooling wind is blown out, the fan motor may have cutting chips or sludge accumulated in it and needs to be cleaned.</li> <li>- If the fan does not operate normally for any other reason, the fan motor needs to be replaced.</li> </ul>
Forcible cooling unit (when using an external cooling unit such as liquid cooling unit)	Dew condensation (over-cooling)	<ul style="list-style-type: none"> <li>- Check that forcible cooling does not cause dew condensation on the motor surface. Dew condensation is likely particularly when the cooling unit continues to run after the machine is stopped. In that case, be sure to make this check.</li> <li>- Dew condensation or water drop on the motor surface can reduce the motor's service life. It is necessary to wipe it dry and take a measure to prevent recurrence.</li> </ul>
	Liquid leakage/clog	<ul style="list-style-type: none"> <li>- Check the cooling pipe for leakage or clog. Do not drive the motor unless the leakage or clog is fixed.</li> <li>- Liquid leakage from a spindle motor with a through hole indicates a failure of the coolant joint. In this case, the joint needs to be replaced.</li> <li>- In the case of liquid leakage from a linear motor (coil slider), the linear motor (coil slider) needs to be replaced.</li> <li>- If the motor gets wet due to liquid leakage or any other cause, it is necessary to clean and dry the motor and perform electric characteristic checks (winding resistance/insulation resistance).</li> </ul>



### Insulation resistance measurement

The following table shows the judgment criteria to be applied when measuring insulation resistance between winding and frame using a megohmmeter (500 VDC).

Insulation resistance	Judgment
100 $\Omega$ or higher	Acceptable
10 to 100 $\Omega$	The winding has begun deteriorating. There is no problem with the performance at present. Be sure to perform periodic inspection.
1 to 10 $\Omega$	The winding has considerably deteriorated. Special care is in need. Be sure to perform periodic inspection.
Lower than 1 $\Omega$	Unacceptable. Replace the motor.

If insulation resistance drops sharply during a short period of time or if the circuit breaker trips, the cutting fluid or other foreign matter may have entered the inside of the motor or cable. In that case, contact the machine tool builder or FANUC for instructions.

#### CAUTION

- Let the motor dry and cool to room temperature before winding or insulation resistance is measured. Otherwise, not only an accurate measurement cannot be performed but also the motor may be damaged.
- The winding or insulation resistance measurement should be performed on the motor alone, with its power line disconnected.  
Measuring insulation resistance with the motor connected to the amplifier may damage the amplifier.
- During insulation resistance measurement, applying voltage to the motor for a long time may further deteriorate the insulation of the motor. Therefore, the measurement of insulation resistance should be performed in a minimum amount of time where possible.
- When disconnecting the power line and other cables, take an appropriate measure, such as labeling, to ensure that they can be restored to their original state.

### 11.2.2.2 Periodic cleaning of a motor

Periodic cleaning is necessary to remove an accumulation of cutting chips or sludge that may eventually cause a failure. Also, leaving the cutting fluid or other chemical substance attached for a long time can reduce the motor's service life substantially. When forcible cooling is provided by a liquid or air cooling unit, check the unit for pipe clog, fan failure, etc. and perform cleaning periodically to ensure that the coolant flows smoothly and that the motor is cooled properly.

#### WARNING

Depending on the type of motor, the handling may involve a risk and require safety education in advance. Also, some machines are difficult for users to clean on their own. If you are to clean the motor, consult with the machine tool builder in advance with regard to the cleaning method, safety education, etc.

### 11.2.2.3 Notes on motor cleaning

A motor is an electric product, which is incompatible with most kinds of fluid. When removing cutting chips, sludge, cutting fluid, etc. during cleaning, note the following.

Note on cleaning	Measure
Do not sprinkle fluid. Do not wash by submerging.	Do not sprinkle or spray detergent or any other fluid over the motor (including its peripheral components), or do not wash the motor by submerging it in such fluid. When cleaning the motor, use a cloth moistened with a small amount of neutral detergent so that the fluid does not enter the inside the motor.
Do not use solvent.	Solvent may damage the motor; do not use one. If the dirt is difficult to remove with neutral detergent, use a cloth moistened with a small amount of industrial alcohol (e.g., IPA). Be careful, however, because rubbing with force or repeatedly may damage the coated or resin surface.
Do not leave the motor wet or moistened.	If the motor is wet or moistened after cleaning, dry it before supplying power and before performing electric tests. When drying the motor in an oven, make sure that the temperature is below 40°C and that hot air does not blow directly against the motor.

### 11.2.2.4 Notes on the cutting fluid (informational)

Depending on the type of cutting fluid used, the motor and amplifier may be affected greatly. Take due care because, even if you ensure that they do not come into direct contact with the fluid, a mist or atmosphere of the fluid can cause the problems described below.

Type of cutting fluid requiring care	Expected problem
Cutting fluid containing highly active sulfur	Some types of cutting fluid contain highly active sulfur. If such cutting fluid enters the inside of the motor or amplifier, it causes copper, silver, and other kinds of metal to corrode, leading to a component failure.
Synthetic cutting fluid with high permeability	Some types of cutting fluid containing such substance as polyalkylene glycol have very high permeability. Such cutting fluid permeates into the inside of the motor, causing insulation deterioration or component failure.
Highly alkaline, water-soluble cutting fluid	Some types of cutting fluid that enhance their alkaline property using such substance as alkanolamine remain highly alkaline - pH10 or higher - when diluted. If such cutting fluid is left attached for a long time, its chemical change will deteriorate the resin and other materials of the motor and amplifier.

Other types of cutting fluid not mentioned above may cause various unexpected problems. If any problem arises for which the cutting fluid is thought to be responsible, consult with the machine tool builder or FANUC.

## 11.2.3 Preventive Maintenance of a Built-in Spindle Motor and Spindle Unit

This subsection contains the safety precautions you need to bear in mind when performing preventive maintenance for a built-in spindle motor (BiI or BiS Series) or the FANUC-NSK spindle unit. In some cases, the work may involve a life-threatening risk or cause substantial damage. Make sure that you fully understand these safety precautions before carrying out the work.

**⚠ WARNING**

- Do not disassemble the spindle. Particularly, the rotor of a synchronous built-in spindle motor (BiS Series) uses strong permanent magnets. The strong magnet force may cause injury or medical appliance malfunction.
- Do not operate a synchronous built-in spindle motor with an external engine. Doing so is very dangerous because it makes the motor act as a power generator, generating high voltage. A power outage is also dangerous because the motor runs freely and, again, generates high voltage. As a safety precaution, a sub module SM (SSM) is connected between motor and amplifier. Do not disconnect the SSM under any circumstances. Also, connect the machine frame to the ground to prevent electric shock.
- A synchronous built-in spindle motor may perform a pole position detection operation when it receives the first rotation command after it is powered on or recovers from an alarm. The pole position detection operation takes 20 to 60 seconds to complete, during which the spindle behaves oddly, e.g., rotating clockwise and counterclockwise alternately in rapid succession. This phenomenon is not abnormal. During the detection operation, do not touch or look down at the spindle, which is a dangerous act.

**⚠ CAUTION**

Performing a test run described in Chapter 3, "TEST RUN METHOD", in Part IV, of "FANUC - NSK SPINDLE UNIT series DESCRIPTIONS (B-65352)" and the inspection and maintenance work described in this manual is the condition for guaranteeing the operation of the FANUC-NSK spindle unit. Be sure to perform the test run and inspection and maintenance work as instructed.

### 11.2.3.1 Routine inspection of the FANUC-NSK spindle unit

Perform the following routine inspections every day at the start of operation so that stable performance can be obtained from the spindle.

	Item	Check
1	Check if the axis, when turned manually, rotates lightly and smoothly. <b>⚠ WARNING</b> When turning the axis manually, be sure to turn off the power to the machine.	
2	Check if cuttings and coolant residuals are attached to the periphery of a slinger.	
3	Check if dust such as cuttings is attached to the spindle taper portion.	
4	For operation at 15,000 min <sup>-1</sup> or more immediately after power-up, increase the speed gradually by using the spindle override function. (This substitutes for a simple test run.)	
5	Check if an abnormal sound is generated.	
6	Check if an abnormal vibration is generated.	
7	Check if an abnormal heat is generated.	

### 11.2.3.2 Maintenance of the FANUC-NSK spindle unit

A FANUC-NSK spindle unit with a grease unit requires periodical maintenance for consumable/wear parts, such as supplying grease. Depending on the use frequency of and damage to parts, **maintenance generally becomes necessary after two years of machine operation or 10,000 hours of spindle operation.** Contact FANUC or the machine tool builder when maintenance becomes necessary. Also, an effective way to reduce the machine down time due to maintenance is to prepare spare parts; consult with the machine tool builder.

### 11.2.3.3 Test run of the FANUC-NSK spindle unit

---

If any of the following cases applies, be sure to contact the machine tool builder and perform a test run as described in **Chapter 3, "TEST RUN METHOD", in Part IV, of "FANUC - NSK SPINDLE UNIT series DESCRIPTIONS (B-65352EN)"**.

- If the spindle unit is rotated for the first time after it is unpacked or attached to the machine
- If the machine or spindle unit has undergone transportation or relocation
- If the spindle unit alone has been stored for a period longer than six months or has not been used for one month or more after installation

**⚠ CAUTION**

FANUC assumes no responsibility for any damage resulting from the failure to perform a test run or improper use of the spindle unit.

### 11.2.3.4 Storage method of the FANUC-NSK spindle unit

---

Apply rust-proof oil to the surface of the spindle unit, pack the spindle unit, and store the packed spindle unit at a location that satisfies the conditions described below. Also, follow the "This Side Up" and "No Pile Up" instructions indicated on the pack surface.

- Indoor well ventilated place not exposed to direct sunlight (place where the temperature varies little, the room temperature is within 5°C to 40°C, and the humidity is 35% to 85% RH)
- Place on the shelf subject to little vibration and dust (Do not place the spindle unit directly on the floor; vibration and dust can damage the bearing or other parts of the spindle.)

Before using the spindle unit after a storage period of one month or more, make necessary checks, such as measuring winding and insulation resistance, examining the appearance for rust and other problems, and checking whether the axis can be turned manually. Depending on the storage period, a test run may be necessary (described earlier).

## 11.2.4 Preventive Maintenance of a Linear Motor

---

The magnet plate of a linear motor contains very strong magnets. When performing the maintenance work, make sure all those engaged in the work fully understand the potential risks involved.

**⚠ WARNING**

- The FANUC linear motors use very strong magnets. Improper handling of the motor is very dangerous and can lead to a serious accident. Particularly, a person wearing a pacemaker or other medical apparatus should stay away from the linear motor; otherwise, the apparatus may malfunction, potentially resulting in a life-threatening accident.
- Those who will come near or touch a linear motor for maintenance work should receive safety education in advance. For details, contact the machine tool builder or FANUC.

### 11.2.4.1 Appearance inspection of the linear motor (magnet plate)

---

Perform an appearance inspection as well during cleaning or other maintenance work. A crack, chip, deformation, or any other abnormality in appearance of the motor can lead to a serious failure in the not-so-distant future. If you find any such abnormality, be sure to report it to the machine tool builder. A scratch or other slight scar on the motor surface can also be a sign of future trouble and needs to be addressed with care. Some suggested appearance inspection items for the magnet plate are described below.

- \* For the coil slider (the side to which the power line is connected), see "Main inspection items" earlier in this manual.

#### Appearance of the magnet plate (which may have a stainless cover)

Appearance inspection item	Measure
Crack or chip in the magnet plate resin Deformation or bulge of the magnet plate or softening of the resin	The magnet plate needs to be replaced. If unattended, it can cause trouble in the not-so-distant future. If the problem is extremely minor, consult with the machine tool builder or FANUC.
The magnet is exposed, or the resin or magnet is floating	The magnet plate needs to be replaced urgently.
Scratch on the magnet plate	Foreign matter may have entered into the motor, or interference between parts is likely. It is necessary to eliminate the cause and take a measure to prevent recurrence.
Floating, bulging, or deformed stainless cover	The cover or magnet plate needs to be replaced.

## 11.2.5 Maintenance of a Detector

### ⚠ CAUTION

- Detectors such as Pulsecoders are precision equipment. When handling a detector, avoid applying shock to it. Also, exercise care to prevent cutting powder, dust, cutting fluid, or other foreign matter from attaching to it.
- Make sure that all connectors are connected properly and securely. A connection failure can cause an alarm or some other problem.
- If the detector and/or connectors are not installed securely, cutting fluid may enter the inside of the detector, making it necessary to replace the detector. In that case, contact the machine tool builder or FANUC.

### NOTE

If you use a detector not manufactured by FANUC, contact the machine tool builder or detector manufacturer for detailed information on the detector.

### 11.2.5.1 Alarms for built-in detectors ( $\alpha_i$ and $\beta_i$ Pulsecoders) and troubleshooting actions

These alarms concern built-in detectors that are connected directly to the control unit (CNC/servo amplifier).

Based on the alarm number and description, take an appropriate action as described in the following subsection, "Detailed troubleshooting methods".

Alarm No.: Alarm	Description	Possible cause	Action	Detailed troubleshooting method
361: ABNORMAL PHASE DATA(INT)	- Communication error in the Pulsecoder - ID data error	- Pulse coder failure - Noise	Replace the Pulsecoder.	(3) (4)
364: SOFT PHASE ALARM(INT)	Position data alarm	- Noise - Entry of cutting fluid	Check the effect of noise. Replace the Pulsecoder.	(1) (3)
365: BROKEN LED(INT)	LED disconnection	- Pulse coder failure	Replace the Pulsecoder.	(3)

Alarm No.: Alarm	Description	Possible cause	Action	Detailed troubleshooting method
366: PULSE MISS(INT)	Small internal signal amplitude	- Pulse coder failure - Noise	Replace the Pulsecoder.	(3) (4)
367: COUNT MISS(INT)	Position data count error	- Pulse coder failure - Noise	Replace the Pulsecoder.	(3) (4)
368: SERIAL DATA ERROR(INT)	Communication interruption	- Cable disconnection - Pulse coder failure - Noise	Check the cable. Replace the Pulsecoder.	(2) (3) (4)
369: DATA TRANS. ERROR(INT)	Communication data alarm	- Noise	Check the effect of noise.	(1)
453: SPC SOFT DISCONNECT ALARM	Position - pole data error	- Pulse coder failure - Entry of cutting fluid	Replace the Pulsecoder.	(3)

### 11.2.5.2 Alarms for separate detectors and troubleshooting actions

These alarms concern separate detectors that are connected to the control unit via a separate detector interface unit (SDU).

Based on the alarm number and description, take an appropriate action as described in the following subsection, "Detailed troubleshooting methods".

Alarm No.: Alarm	Description	Possible cause	Action	Detailed troubleshooting method
380: BROKEN LED(EXT)	LED disconnection	- Detector failure	Replace the detector.	(4)
382: COUNT MISS(EXT)	Position data count error			
383: PULSE MISS(EXT)	Small internal signal amplitude			
384: SOFT PHASE ALARM(EXT)	Position data alarm			
385: SERIAL DATA ERROR(EXT)	Communication interruption	- Cable disconnection - Noise - Detector failure	Check the cable. Check the effect of noise. Replace the detector.	(2) (1) (4)
386: DATA TRANS. ERROR(EXT)	Communication data alarm	- Noise	Check the effect of noise.	(1)
381: ABNORMAL PHASE (EXT) 387: ABNORMAL ENCODER(EXT)	For details, contact the machine tool builder or detector manufacturer.			

### 11.2.5.3 Detailed troubleshooting methods

#### (1) Checking the effect of noise

Check the value on the diagnostics data No. 356 (for a built-in detector) or 357 (for a separate detector) of the CNC unit.

Normally, 0 is displayed. However, if the position data from the Pulsecoder becomes unstable due to noise or some other factor, this value is incremented. The value is cleared when the CNC unit is powered off. Immediately after the power is turned on, 0 is displayed.

#### (2) Checking the cable

Check whether the feedback cable is not disconnected and whether the connector is properly plugged.

### (3) Replacing the Pulsecoder

#### (3)-1 Pulse coder replacement procedure

<1> Remove the four M4 hexagon socket head cap screws fastening the Pulsecoder. The M3 bolts fastening the Pulsecoder cover do not need to be loosened. (See the figure at right.)

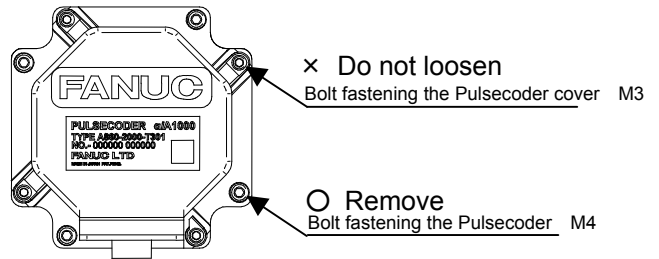

<2> Remove the Pulsecoder and Oldham's coupling (see the following figure).

<3> Set the new Pulsecoder and Oldham's coupling on the motor. Adjust the direction of the mate Oldham's coupling to that of the Oldham's coupling so that the teeth are engaged.

Push in the Pulsecoder until the O ring fits in the joint between the motor and Pulsecoder. Take care so that the O ring of the Pulsecoder is not bitten.

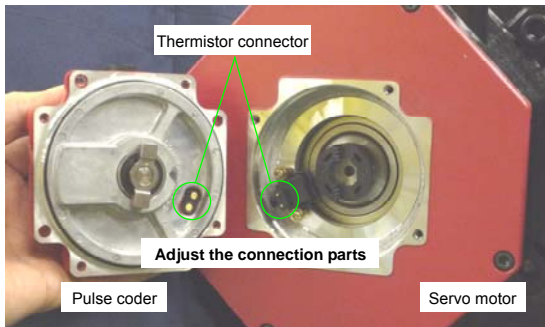
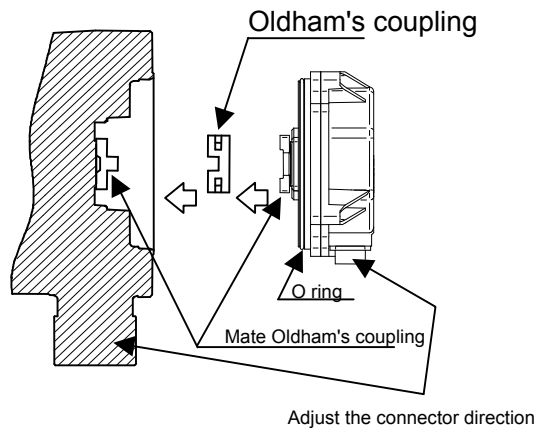

Attach the Pulsecoder in such a direction that the power connector of the servo motor and the feedback cable of the Pulsecoder face the same direction or that the thermistor connection parts of the servo motor and Pulsecoder match each other (see the figure at left).

<4> Fastening the Pulsecoder with the four M4 hexagon socket head cap screws in the reverse order of removing the Pulsecoder (<1>). (Appropriate torque: 1.5 Nm)

#### (3)-2 Feedback cable plugging procedure

Plug in the feedback cable connector, as instructed in the procedure below, and check that the connector is securely connected.

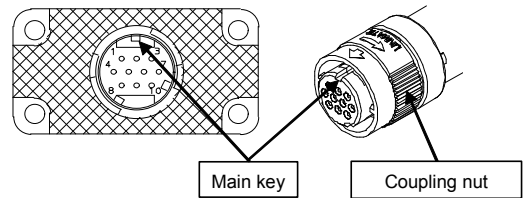

<1> Check the plugging side and key direction. Check that the plugging side is free of foreign matter, such as dirt and oil.

<2> Plug in the feedback cable connector. Hold the connector, as shown in the figure at right. Plug in the connector until you hear a click.

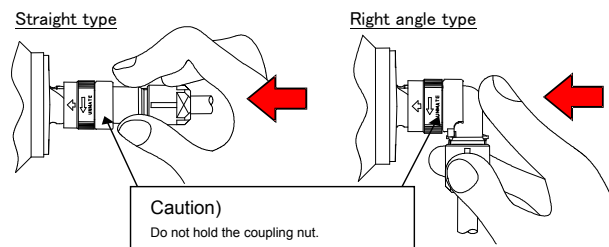

<3> Check the connection condition.

1. Check that the arrow mark of the connector is at the center, as shown in the figure at right. If the arrow mark is not at the center, turn the coupling nut manually until the mark comes to the appropriate position.

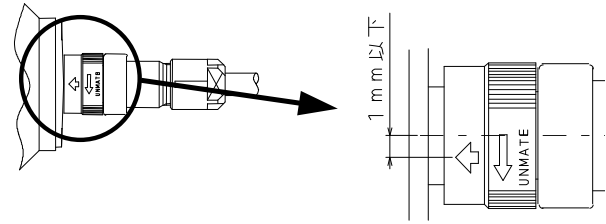

2. Hold the connector by the same part as in <2>, and pull it lightly toward you to check that the connector does not come off. Do not pull the connector with force.

**(4) If troubleshooting is difficult for the user**

If the problem is difficult for the user to troubleshoot because it is due to a detector failure or noise, consult with the machine tool builder or FANUC.

**11.2.5.4 Maintenance of βiS motor Pulsecoders**

Problems concerning the Pulsecoders of the motors listed in the table below require the maintenance (replacement) of the entire motor (it is not possible to maintain the Pulsecoder alone).

Motor model	Motor specification	Remarks
βiS 0.2/5000	A06B-0111-Bx03	x=1,2,4,5
βiS 0.3/5000	A06B-0112-Bx03	
βiS 0.4/5000	A06B-0114-Bx03#0y00	x=1,2,4,5 y=0,1
βiS 0.5/6000	A06B-0115-Bx03#0y00	
βiS 1/6000	A06B-0116-Bx03#0y00	



## 11.3 PREVENTIVE MAINTENANCE OF SERVO AMPLIFIERS

### 11.3.1 Warnings, Cautions, and Notes on Preventive Maintenance of Servo Amplifiers

This subsection contains the safety precautions on preventive maintenance of a servo amplifier (a generic term to refer to the power supply, servo amplifier, spindle amplifier, and other sub modules of a motor drive unit). These precautions are classified into "warnings", "cautions", and "notes" according to their bearing on safety. Make sure that you understand and comply with these precautions when carrying out the maintenance work.

#### **WARNING**

- **Make sure that you are safely dressed and have a safe working environment when performing preventive maintenance for a servo amplifier.**
  - Be dressed safely, e.g. by wearing gloves and safety shoes, to protect against injury due to an edge or protrusion and electric shock.
  - Have the work done by more than one person, where possible, so that immediate action can be taken if an accident occurs when handling a motor.
  - A servo amplifier and AC reactor contain heavy components. Be careful when transporting them or mounting them on the power magnetic cabinet. Also be careful not to get your fingers caught between the power magnetics cabinet and servo amplifier.
- **Before turning on the power, check that the door of the power magnetics cabinet and all other doors.**
  - Ensure that the door of the power magnetics cabinet containing the servo amplifier, as well as all other doors, are closed and locked except during maintenance work.
- **When the need arises to open the door of the power magnetics cabinet, only a person trained in the maintenance of the corresponding machine or equipment should do the task after shutting off the power supply to the power magnetics cabinet by opening both the input circuit breaker of the power magnetics cabinet and the factory switch used to supply power to the cabinet.**
- **Be careful about electric shock, fire, and other accidents.**
  - If the machine must be operated with the door open for adjustment or some other purpose, the operator must keep his or her hands and tools well away from any dangerous voltages. Such work must be done only by a person trained in the maintenance of the machine or equipment.
  - Ensure that the door of the power magnetics cabinet is locked so that the door cannot be opened by anyone, except service personnel or a qualified person trained in maintenance to prevent electric shock, when the servo amplifier is powered on.
  - When the need arises for an operator to open the door of the power magnetics cabinet and perform an operation, ensure that the operator is sufficiently educated in safety or that a protective cover is added to prevent the operator from touching any dangerous part.
  - The servo amplifier contains a large-capacity electrolytic capacitor in it and remains charged for a while after the power is shut off. Before touching the servo amplifier for maintenance or some other purpose, measure the residual voltage of the DC link connection using a tester and check that the red LED for indicating charging is in progress is not lit, in order to ensure safety.
  - After wiring, be sure to close the servo amplifier cover.
  - A loose screw or poor connector contact can cause a motor malfunction or overheating, connection to ground, or short-circuit. Be extremely careful with power supply lines, motor power lines, and DC link connections through which a large electric current flows, because a loose screw or poor connector contact may lead to a fire. Tighten screws and connectors using the specified screw tightening torque.

- The surfaces of the regenerative discharge unit and heat radiator may become very hot. Do not touch them directly by hand.
- **When operating the machine for the first time after preventive maintenance, check that the machine operates as instructed.**
  - To check whether the machine operates as instructed, first specify a small value for the motor and then increase the value gradually. If the motor operates abnormally, perform an emergency stop immediately.
  - When pressing the emergency stop button, check that the motor stops immediately and that the power being supplied to the amplifier is shut off by the magnetic contactor.
- **Notes on alarms**
  - If the machine stops due to an alarm, check the alarm number. Depending on the alarm issued, if the power is supplied without replacing the failed component, another component may be damaged, making it difficult to identify the original cause of the alarm.
  - Before resetting an alarm, ensure that the original cause of the alarm has been removed.
- **If the motor causes any abnormal noise or vibration while operating, stop it immediately.**
  - Using the motor in spite of the abnormal noise or vibration may damage the servo amplifier.
- **Do not disassemble or modify a servo amplifier.**

Do not disassemble or modify a servo amplifier in any way not specified by FANUC; doing so can lead to a failure.

**CAUTION**

- **Notes on servo amplifier replacement and wiring**
  - The work of servo amplifier replacement and wiring should be carried out by a person trained in the maintenance of the machine and equipment concerned.
  - When replacing a servo amplifier, check that the combination of the amplifier and the motor is appropriate.
  - Check that the servo amplifier is securely mounted on the power magnetics cabinet. If there is any clearance between the power magnetics cabinet and the surface on which the amplifier is mounted, dust entering the gap may hinder the normal operation of the servo amplifier.
  - Ensure that the power supply lines, motor power lines, and signal lines are each connected to the correct terminal or connector.
  - Unless otherwise instructed, do not unplug a connector and plug it back with the power on; doing so may cause the servo amplifier to fail.
  - When mounting or unmounting the servo amplifier, exercise care not to get your fingers caught between the servo amplifier and power magnetics cabinet.
  - Take care not to lose track of removed screws. Turning on the power with any lost screw left in the unit may damage the machine.
  - Exercise care to prevent the power supply lines and motor power lines from being connected to the ground or being short-circuited.
  - Protect the lines from any stress such as bending. Handle the line ends appropriately.
- **Be careful about the handling of a servo amplifier.**
  - Do not disassemble a servo amplifier. Doing so poses the risk of electric shock, because the capacitor may remain charged.
  - Do not apply shock to a servo amplifier. Doing so may damage its components, potentially causing the amplifier to malfunction.

- Do not apply an excessively large force to plastic parts. If a plastic section breaks, it may damage internal parts, thus hindering normal operation or leading to a risk of injury due to a broken section.
- **Be careful about the operating environment of a servo amplifier.**
  - Prevent conductive, combustible, or corrosive foreign matter, mist, or drops of water from entering the inside of the unit. The entry of any such material may cause the unit to explode, break, malfunction, etc.
  - Exercise care to prevent cutting fluid, oil mist, cutting chips, or other foreign matter from attaching to the radiator or fan motor exposed to the outside of the power magnetics cabinet. Otherwise, the servo amplifier may become unable to meet its specifications. The service lives of the fan motor and semiconductors can also be reduced.
- **Clean the heat sink and fan motor on a regular basis.**
  - Replace the filter of the power magnetics cabinet on a regular basis.
  - Before cleaning the heat sink, shut down the power and ensure that the temperature of the heat sink is as cool as the room temperature. The heat sink is very hot immediately after power shutdown, touching it may cause burn injury.
  - When cleaning the heat sink by blowing air, be careful about dust scattering. Conductive dust attached to the servo amplifier or its peripheral equipment can lead to a failure.

**NOTE**

- **Make sure that there is sufficient maintenance clearance around the doors of the machine and equipment.**
- **Do not step or sit on the servo amplifier, or do not apply shock to it.**
- **Do not remove a nameplate from a motor.**
  - The nameplate is necessary to identify the servo amplifier during maintenance work.
  - If a nameplate comes off, be careful not to lose it.

**NOTE**

- This manual is focused on the preventive maintenance work to be performed for a FANUC servo amplifier. The information contained herein may not apply depending on the type or configuration of the machine. When reading this manual, refer to the manual of the machine as well. If you have any questions or doubts, do not act on your own; please contact the machine tool builder or FANUC.
- For detailed information about a servo amplifier, see the manual list shown earlier and, if necessary, obtain the latest version of the corresponding manual.

## 11.3.2 Preventive Maintenance of a Servo Amplifier

To use a servo amplifier safely throughout its entire service life, perform daily and periodic inspections.

### ⚠ CAUTION

- The preventive maintenance method differs from machine to machine in many respects. Depending on the machine in use, it may be difficult for the user to perform periodic inspection or cleaning. If you are not sure about anything as to preventive maintenance, consult with the machine tool builder and ensure that you can perform periodic inspection and cleaning.
- The machine should be used within the scope of specification defined by the machine tool builder. Using the machine in any way that is outside the specified scope can reduce the servo amplifier's service life or cause a failure.

Inspection part	Inspection item	Inspection interval		Judgment criterion
		Routine	Periodic	
Operating environment	Ambient temperature	√		Around the power magnetics cabinet: 0°C - 45°C Inside the power magnetics cabinet: 0°C - 55°C
	Humidity	√		90% or below RH (dew condensation not allowed)
	Dust/oil mist	√		There shall be no dust or oil mist attached near the servo amplifier.
	Cooling air path	√		The cooling fan shall be operating normally without the air flow being interrupted.
	Abnormal vibration/noise	√		- No abnormal noise or vibration shall be present that has not been experienced in the past. - Vibration near the servo amplifier shall be 0.5 G or less.
	Supply voltage	√		200-V input type: Within 200 - 240 V 400-V input type: Within 400 - 480 V
Servo amplifier	General	√		There shall be no abnormal noise or smell, and there shall be no dust or oil mist attached.
	Screw		√	There shall be no loose screw.
	Fan motor <sup>(NOTE 1, 2)</sup>	√		- There shall be no abnormal vibration or noise, and the fan blades shall be rotating normally. - There shall be no dust or oil mist attached.
	Connector		√	There shall be no loose or broken connector.
	Cable		√	There shall be no sign of overheating or sheath deterioration (discoloration or crack).
CNC	Absolute <sup>(NOTE 2)</sup> Pulse coder battery	√		The machine operator's panel or screen shall not display the alarm indicating the battery voltage of the absolute Pulsecoder is low.
External equipment	Magnetic contactor		√	The contactor shall not rattle or chatter.
	Ground fault interrupter		√	The interrupter shall be able to trip.
	AC reactor		√	There shall be no hum.

### NOTE

- 1 Fan motors are periodic-replacement parts. It is recommended to inspect fan motors on a routine basis and replace them in a preventive manner.
- 2 Fan motors and batteries are periodic-replacement parts. It is recommended to keep spare parts.

## 11.3.3 Maintenance of a Servo Amplifier

### 11.3.3.1 Display of the servo amplifier operation status







The STATUS LEDs on the front of the servo amplifier indicate the operation status of the servo amplifier (whether it is operating normally, the type of alarm, etc.). Use these LEDs for maintenance, inspection, troubleshooting, etc.

#### CAUTION

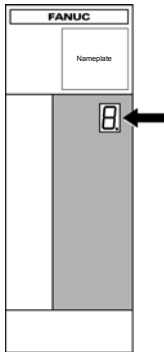





A servo amplifier failure may arise from a combination of multiple causes, in which case it can be difficult to identify all those causes. Handling the failure in an improper way may worsen the problem. It is therefore important to analyze the failure status minutely and identify the true cause or causes of the failure. There may be cases in which the failure appears to have been fixed but later recurs or cause a more serious trouble. If you are not sure about the root cause of or corrective action for a failure, do not act on your own; please contact the machine tool builder or FANUC for instructions on proper action.

[ $\alpha$ i series]

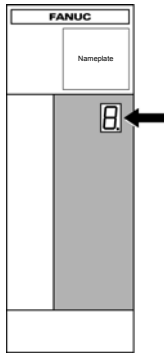









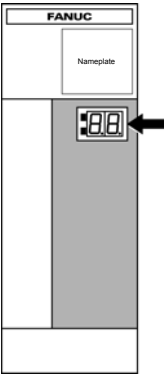
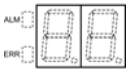





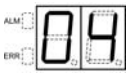

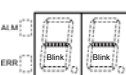

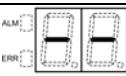
(1) Power supply

STATUS LED position	STATUS display	Description
		The STATUS LED is off. Control power has not been supplied, cable is faulty, or control power circuit is defective.
		Not ready status The main circuit is not supplied with power (magnetic contactor is off); emergency stop state.
		Ready status The main circuit is supplied with power (magnetic contactor is on); the power supply is ready for operation.
		Warning state (The dot at the lower right lights.) The power supply has failed; an alarm has occurred after a certain time of operation. The warning type is indicated by the character displayed.
		Alarm status The alarm type is indicated by the character displayed.

(2) Servo amplifier

STATUS LED position	STATUS display	Description
		The STATUS LED is off. Control power has not been supplied, cable is faulty, or control power circuit is defective.
		The control power is short-circuited (- blinks). Cable failure
		Waiting for the READY signal from the CNC.
		Ready status The servo motor is excited.
		Alarm status The alarm type is indicated by the character displayed.

(3) Spindle amplifier

STATUS LED position	STATUS display	Description
	 ALM:  ERR: 	The STATUS LED is off. Control power has not been supplied, cable is faulty, or control power circuit is defective.
	 ALM:  ERR: 	After control power is turned on, the spindle software series is displayed (for approx. 1 second). The last two digits of the spindle software series number are displayed.
	 ALM:  ERR: 	The spindle software version is displayed (for approx. 1 second following the display of the spindle software series). [Display] 01,02,03,... → [Version] A, B, C,...
	 ALM:  ERR: 	The CNC is not powered on (- - blinks). Waiting for serial communication and parameter loading completion.
	 ALM:  ERR: 	Parameter loading completed The motor is not excited.
	 ALM:  ERR: 	Ready status The spindle motor is excited.
	 ALM:  ERR: 	Alarm status The alarm type is indicated by the character displayed.
	 ALM:  ERR: 	Error status (invalid sequence or parameter setting error) The error type is indicated by the character displayed.

[βi SV series]

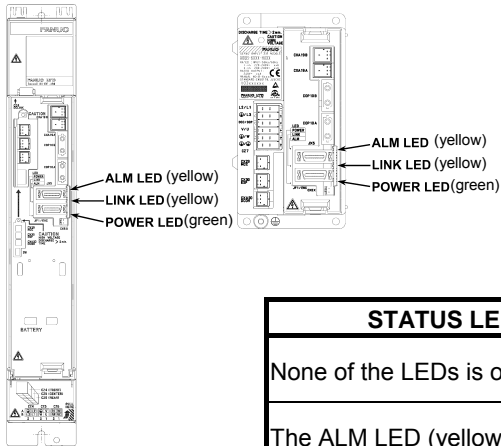

STATUS LED	Description
None of the LEDs is on.	Control power has not been supplied, cable is faulty, or control power circuit is defective.
The ALM LED (yellow) is on.	Alarm status The alarm type is indicated by the character displayed.
The LINK LED (green) is on.	Communication between CNC and servo amplifier is progressing normally.
The POWER LED (green) is on.	The control power of the servo amplifier (5 V) is normal.

### 11.3.3.2 Replacement of a fan motor

[αi series]

- (1) Fan motor for internal cooling

Replace the internal fan motor, according to the procedure shown in the figure below.

When replacing the fan motor, be careful about the direction of the fan motor (air blow direction), the direction of the connector, etc.

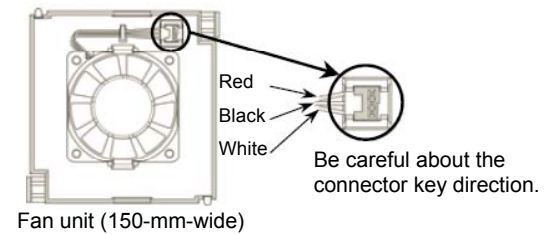
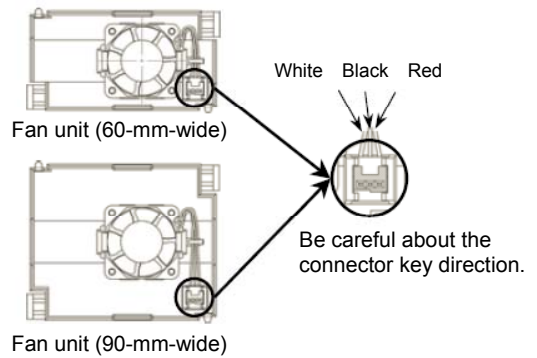
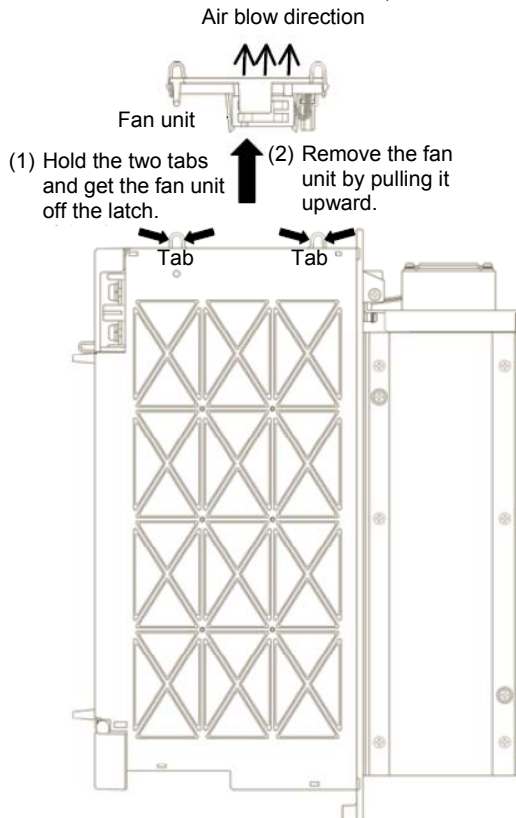

\* Be careful about the fan motor and connector directions.

- (2) Fan motor for cooling external heat sink
  - <1> Remove the two sheet metal mounting screws (for the 60-mm-wide model only), and detach the fan motor from the unit together with the sheet metal.
  - <2> Remove the fan motor mounting screws (two for one fan motor and four for two fan motors).
  - <3> Remove the connector mounting screws (two and four for the 300-mm-wide model).
 When replacing the fan motor, be careful about the direction of the fan motor (air blow direction), the direction of the connector, etc.

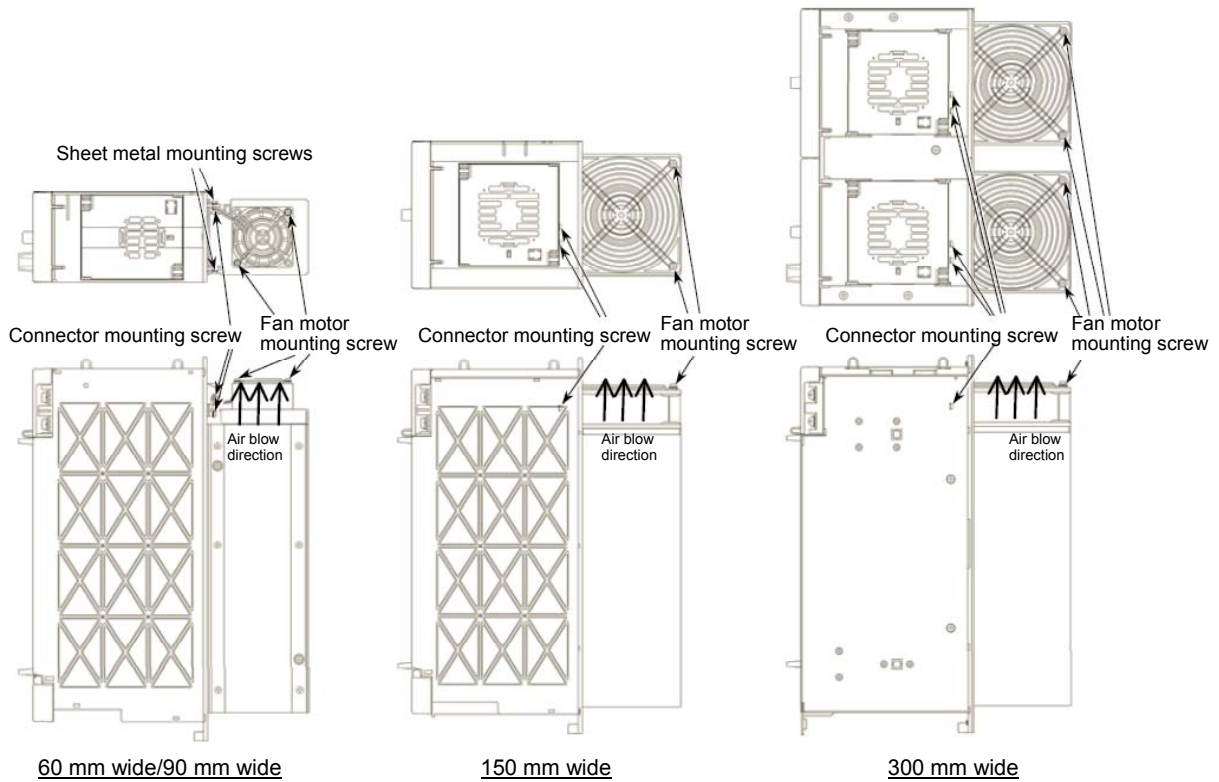

[*βi* series]

Replace the fan motor, according to the procedure shown in the figure below. When replacing the fan motor, be careful about the direction of the fan motor (air blow direction), the direction of the connector, etc.

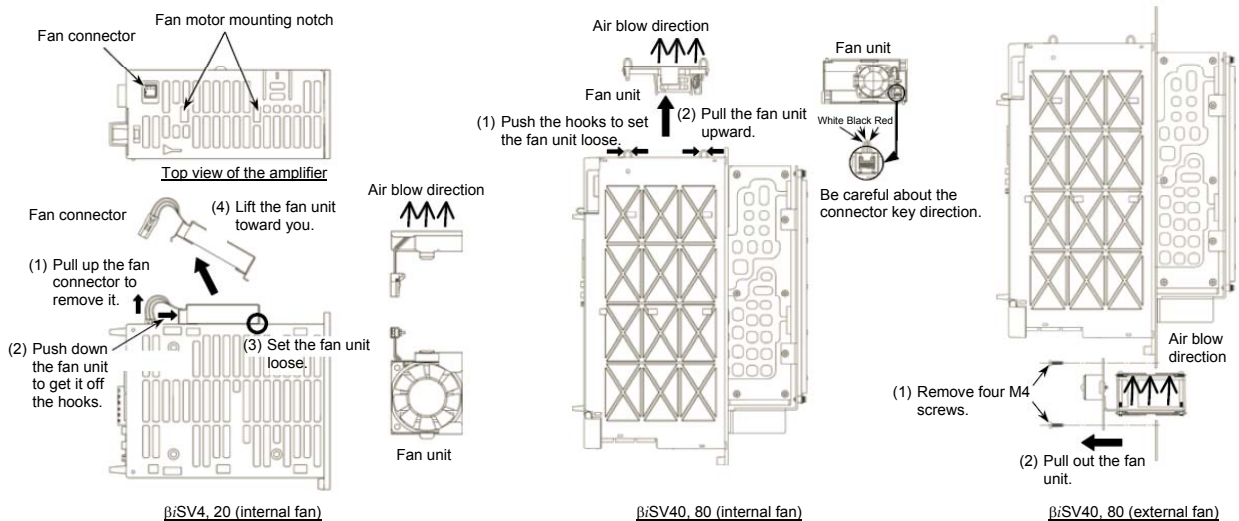



# **APPENDIX**



# A ALARM LIST

Appendix A, "ALARM LIST", consists of the following sections:

A.1	ALARM LIST (CNC)	617
	(1) Alarms on program and operation (PS alarm)	617
	(2) Background edit alarms (BG alarm)	617
	(3) Communication alarms (SR alarm)	617
	(4) Parameter writing alarm (SW alarm)	663
	(5) Servo alarms (SV alarm)	663
	(6) Overtravel alarms (OT alarm)	670
	(7) Memory file alarms (IO alarm)	671
	(8) Alarms requiring power to be turned off (PW alarm)	672
	(9) Spindle alarms (SP alarm)	673
	(10) Overheat alarms (OH alarm)	675
	(11) Other alarms (DS alarm)	676
	(12) Malfunction prevention function alarms (IE alarm)	681
A.2	ALARM LIST (PMC)	681
	A.2.1 Messages That May Be Displayed on the PMC Alarm Screen	681
	A.2.2 PMC System Alarm Messages	690
	A.2.3 Operation Errors	695
	A.2.4 I/O Communication Error Messages	710
A.3	ALARM LIST (SERIAL SPINDLE)	715
A.4	ERROR CODES (SERIAL SPINDLE)	727

## A.1 ALARM LIST (CNC)

### (1) Alarms on program and operation (PS alarm)

### (2) Background edit alarms (BG alarm)

### (3) Communication alarms (SR alarm)

Alarm numbers are common to all these alarm types.

Depending on the state, an alarm is displayed as in the following examples:

PS"alarm number" Example: PS0003

BG"alarm number" Example: BG0085

SR"alarm number" Example: SR0001

Number	Message	Description
0001	TH ERROR	A TH error was detected during reading from an input device. The read code that caused the TH error and how many statements it is from the block can be verified in the diagnostics screen.
0002	TV ERROR	An error was detected during the single-block TV error. The TV check can be suppressed by setting bit 0 (TVC) of parameter No. 0000 to "0".
0003	TOO MANY DIGIT	Data entered with more digits than permitted in the NC instruction word. The number of permissible digits varies according to the function and the word.
0004	INVALID BREAK POINT OF WORDS	NC word(s) address + numerical value not in word format. This alarm is also generated when a custom macro does not contain a reserved word, or does not conform to the syntax.

Number	Message	Description
0005	NO DATA AFTER ADDRESS	NC word(s) address + numerical value not in word format. This alarm is also generated when a custom macro does not contain a reserved word, or does not conform to the syntax.
0006	ILLEGAL USE OF MINUS SIGN	A minus sign (-) was specified at an NC instruction word or system variable where no minus signal may be specified.
0007	ILLEGAL USE OF DECIMAL POINT	A decimal point (.) was specified at an address where no decimal point may be specified, or two decimal points were specified.
0009	IMPROPER NC-ADDRESS	An illegal address was specified, or parameter 1020 is not set.
0010	IMPROPER G-CODE	1) An unusable G code is specified. 2) The continuous circle motion-based groove cutting option parameter is not effective. 3) The continuous circle motion-based groove cutting enable signal is "0".
0011	FEED ZERO ( COMMAND )	1) The cutting feedrate instructed by an F code has been set to 0. 2) This alarm is also generated if the F code instructed for the S code is set extremely small in a rigid tapping instruction as the tool cannot cut at the programmed lead. 3) During continuous circle motion-based groove cutting, correct Q or F value is not specified or the acceleration clamp value for continuous circle motion in parameter No. 3490 is invalid.
0014	CAN NOT COMMAND G95	A synchronous feed is specified without the option for threading / synchronous feed. Modify the program.
0015	TOO MANY SIMULTANEOUS AXES	A move command was specified for more axes than can be controlled by simultaneous axis control. Either add on the simultaneous axis control extension option, or divide the number of programmed move axes into two blocks.
0020	OVER TOLERANCE OF RADIUS	An arc was specified for which the difference in the radius at the start and end points exceeds the value set in parameter No. 3410. Check arc center codes I, J and K in the program. The tool path when parameter No. 3410 is set to a large value is spiral.
0021	ILLEGAL PLANE SELECT	The plane selection instructions G17 to G19 are in error. Reprogram so that same 3 basic parallel axes are not specified simultaneously. This alarm is also generated when an axis that should not be specified for plane machining is specified, for example, for circular interpolation or involute interpolation. To enable programming of 3 or more axes, the helical interpolation option must be added to each of the relevant axes.
0022	R OR I,J,K COMMAND NOT FOUND	The command for circular interpolation lacks arc radius R or coordinate I, J, or K of the distance between the start point to the center of the arc.
0025	CIRCLE CUT IN RAPID (F0)	F0 (rapid traverse in inverse feed or feed specified by an F code with 1–digit number) was specified during circular interpolation (G02, G03) or involute interpolation (G02.2, G03.2).

Number	Message	Description
0027	NO AXES COMMANDED IN G43/G44	No axis is specified in G43 and G44 blocks for the tool length offset type C. Offset is not canceled but another axis is offset for the tool length offset type C. Multiple axes were specified for the same block when the tool length compensation type is C.
0029	ILLEGAL OFFSET VALUE	Illegal offset No.
0030	ILLEGAL OFFSET NUMBER	An illegal offset No. was specified. This alarm is also generated when the tool shape offset No. exceeds the maximum number of tool offset sets in the case of tool offset memory B.
0031	ILLEGAL P COMMAND IN G10	The relevant data input or option could not be found for the L No. of G10. No data setting address such as P or R was specified. An address command not concerned with data setting was specified. An address varies with the L No. The sign or decimal point of the specified address is in error, or the specified address is out of range.
0032	ILLEGAL OFFSET VALUE IN G10	In setting an offset amount by G10 or in writing an offset amount by system variables, the offset amount was excessive.
0033	NO INTERSECTION AT CUTTER COMPENSATION	The intersection cannot be obtained by the intersection calculation in tool radius/tool nose radius compensation. Modify the program.
0034	NO CIRC ALLOWED IN STUP/EXT BLK	In tool radius/tool nose radius compensation, a startup or cancellation is performed in the G02 or G03 mode. Modify the program.
0035	CAN NOT COMMANDED G31	<ul style="list-style-type: none"> <li>- G31 cannot be specified. This alarm is generated when a G code (such as for tool radius/tool nose radius compensation) of group 07 is not canceled.</li> <li>- A torque limit skip was not specified in a torque limit skip command (G31P98 or P99). Specify the torque limit skip in the PMC window or the like. Or, specify the torque limit override by address Q.</li> </ul>
0037	CAN NOT CHANGE PLANE IN G41/G42	The compensation plane G17/G18/G19 was changed during cutter or tool-nose radius compensation. Modify the program.
0038	INTERFERENCE IN CIRCULAR BLOCK	Overcutting will occur in tool radius/tool nose radius compensation because the arc start point or end point coincides with the arc center. Modify the program.
0039	CHF/CNR NOT ALLOWED IN G41,G42	Chamfering or corner R was specified with a start-up, a cancel, or switching between G41 and G42 in G41 and G42 commands (tool radius/tool nose radius compensation). The program may cause overcutting to occur in chamfering or corner R. Modify the program.
0041	INTERFERENCE IN CUTTER COMPENSATION	In tool radius/tool nose radius compensation, excessive cutting may occur. Modify the program.
0042	G45/G48 NOT ALLOWED IN CRC	Tool offset (G45 to G48) is commanded in tool radius compensation or three-dimensional cutter compensation. Modify the program.
0043	ILLEGAL T-CODE COMMAND	On a system with a DRILL-MATE ATC installed, M06 is not specified in a block that specifies a T code. Alternatively, a T code beyond the allowable range is specified.
0044	G27-G30 NOT ALLOWED IN FIXED CYC	One of G27 to G30 is commanded in canned cycle mode. Modify the program.

Number	Message	Description
0045	ADDRESS Q NOT FOUND (G73/G83)	In a high-speed peck drilling cycle (G73) or peck drilling cycle (G83), the amount of each-time cutting is not specified by address Q, or Q0 is specified. Modify the program.
0046	ILLEGAL REFERENCE RETURN COMMAND	A command for a return to the second, third or fourth reference position is error. (The address P command is in error.) Although an option for a return to the third or fourth reference position was not set, 3 or 4 was specified in address P.
0047	ILLEGAL AXIS SELECT	Two or more parallel axes (in parallel with a basic axis) have been specified upon start-up of 3-dimensional tool compensation or three-dimensional coordinate conversion.
0048	BASIC 3 AXIS NOT FOUND	Start-up of 3-dimensional tool compensation or three-dimensional coordinate conversion has been attempted, but the three basic axes used when Xp, Yp, or Zp is omitted are not set in parameter No. 1022.
0049	ILLEGAL COMMAND(G68,G69)	When three-dimensional coordinate conversion (G68 or G69) was specified, the tool compensation was not canceled. Or, programs of three-dimensional coordinate conversion (G68, G69) and tool compensation (G43, G44 or G49) were not nested. Or, the three-dimensional coordinate conversion was specified during the tool length compensation and another tool length compensation was specified.
0050	CHF/CNR NOT ALLOWED IN THRD BLK	Chamfering or corner R is commanded in the thread cutting block. Modify the program.
0051	MISSING MOVE AFTER CNR/CHF	Improper movement or the move distance was specified in the block next to the chamfering or corner R block. Modify the program.
0052	CODE IS NOT G01 AFTER CHF/CNR	The block next to the chamfering or corner R block is not G01 (or vertical line). Modify the program.
0053	TOO MANY ADDRESS COMMANDS	In the chamfering and corner R commands, two or more of I, J, K and R are specified.
0054	NO TAPER ALLOWED AFTER CHF/CNR	A block in which chamfering in the specified angle or the corner R was specified includes a taper command. Modify the program.
0055	MISSING MOVE VALUE IN CHF/CNR	In chamfering or corner R block, the move distance is less than chamfer or corner R amount. Modify the program.
0056	NO END POINT & ANGLE IN CHF/CNR	In direct dimension drawing programming, both an end point and an angle were specified in the block next to the block in which only an angle was specified (Aa). Modify the program.
0057	NO SOLUTION OF BLOCK END	Block end point is not calculated correctly in direct dimension drawing programming. Modify the program.
0058	END POINT NOT FOUND	Block end point is not found in direct dimension drawing programming. Modify the program.
0060	SEQUENCE NUMBER NOT FOUND	[External data input/output] The specified number could not be found for program number and sequence number searches. Although input/output of a pot number of tool data or offset input was requested, no tool number was input after power on. The tool data corresponding to the entered tool number could not be found. [External workpiece number search] The program corresponding to the specified workpiece number could not be found. [Program restart] In the program restart sequence number specification, the specified sequence number could not be found.

Number	Message	Description
0061	P OR Q COMMAND IS NOT IN THE MULTIPLE REPETIVE CYCLES BLOCK	Address P or Q is not specified in multiple repetitive cycle (G70, G71, G72, or G73) command.
0062	THE CUTTING AMOUNT IS ILLEGAL IN THE ROUGH CUTTING CYCLE	A zero or a negative value was specified in a multiple repetitive canned rough-cutting cycle (G71 or G72) as the depth of cut.
0063	THE BLOCK OF A SPECIFIED SEQUENCE NUMBER IS NOT FOUND	The sequence number specified by addresses P and Q in multiple repetitive cycle (G70, G71, G72, or G73) command cannot be searched.
0064	THE FINISHING SHAPE IS NOT A MONOTONOUS CHANGE(FIRST AXES)	In a shape program for the multiple repetitive canned rough-cutting cycle (G71 or G72), the command for the first plane axis was not a monotonous increase or decrease.
0065	G00/G01 IS NOT IN THE FIRST BLOCK OF SHAPE PROGRAM	In the first block of the shape program specified by P of the multiple repetitive canned cycle (G70, G71, G72, or G73), G00 or G01 was not specified.
0066	UNAVAILABLE COMMAND IS IN THE MULTIPLE REPETIVE CYCLES BLOCK	An unavailable command was found in a multiple repetitive canned cycle (G70, G71, G72, or G73) command block.
0067	THE MULTIPLE REPETIVE CYCLES IS NOT IN THE PART PROGRAM STORAGE	A multiple repetitive canned cycle (G70, G71, G72, or G73) command is not registered in a tape memory area.
0069	LAST BLOCK OF SHAPE PROGRAM IS AN ILLEGAL COMMAND	In a shape program in the multiple repetitive canned cycle (G70, G71, G72, or G73), a command for the chamfering or corner R in the last block is terminated in the middle.
0070	NO PROGRAM SPACE IN MEMORY	The memory area is insufficient. Delete any unnecessary programs, then retry.
0071	DATA NOT FOUND	<ul style="list-style-type: none"> <li>- The address to be searched was not found.</li> <li>- The program with specified program number was not found in program number search.</li> <li>- In the program restart block number specification, the specified block number could not be found.</li> </ul> Check the data.
0072	TOO MANY PROGRAMS	The number of programs to be stored exceeded 63 (basic), 125 (option), 200 (option), 400 (option) or 1000 (option). Delete unnecessary programs and execute program registration again.
0073	PROGRAM NUMBER ALREADY IN USE	The commanded program number has already been used. Change the program number or delete unnecessary programs and execute program registration again.
0074	ILLEGAL PROGRAM NUMBER	The program number is other than 1 to 9999. Modify the program number.
0075	PROTECT	An attempt was made to register a program whose number was protected. In program matching, the password for the encoded program was not correct. An attempt was made to select a program being edited in the background as the main program. An attempt was made to call a program being edited in the background as a subprogram.

Number	Message	Description
0076	PROGRAM NOT FOUND	The specified program is not found in the subprogram call, macro call or graphic copy. The M, G, T or S codes are called by a P instruction other than that in an M98, G65, G66, G66.1 or interrupt type custom macro, and a program is called by a No. 2 auxiliary function code. This alarm is also generated when a program is not found by these calls.
0077	TOO MANY SUB,MACRO NESTING	The total number of subprogram and macro calls exceeds the permissible range. Another subprogram call was executed during an external memory subprogram call.
0078	SEQUENCE NUMBER NOT FOUND	The specified sequence No. was not found during sequence number search. The sequence No. specified as the jump destination in GOTO— and M99P— was not found.
0079	PROGRAM NOT MATCH	The program in memory does not match the program stored on tape. Multiple programs cannot be matched continuously when bit 3 (ABG0) of parameter No. 2200 is set to "1". Set bit 3 of parameter No. 2200 to "0" before executing a match.
0080	G37 MEASURING POSITION REACHED SIGNAL IS NOT PROPERLY INPUT	<ul style="list-style-type: none"> <li>- For machining center series When the tool length measurement function (G37) is performed, a measuring position reached signal goes 1 in front of the area determined by the <math>\epsilon</math> value specified in parameter No.6254. Alternatively, the signal does not go 1.</li> <li>- For lathe When the automatic tool compensation function (G36, G37) is used, a measuring position reached signals (XAE1, XAE2) does not go 1 within the range determined by the <math>\epsilon</math> value specified in parameters Nos. 6254 and 6255.</li> </ul>
0081	G37 OFFSET NO. UNASSIGNED	<ul style="list-style-type: none"> <li>- For machining center series The tool length measurement function (G37) is specified without specifying an H code. Correct the program.</li> <li>- For lathe The automatic tool compensation function (G36, G37) is specified without specifying an T code. Correct the program.</li> </ul>
0082	G37 SPECIFIED WITH H CODE	<ul style="list-style-type: none"> <li>- For machining center series The tool length measurement function (G37) is specified together with an H code in the same block. Correct the program.</li> <li>- For lathe The automatic tool compensation function (G36, G37) is specified together with an T code in the same block. Correct the program.</li> </ul>



Number	Message	Description
0083	G37 IMPROPER AXIS COMMAND	<ul style="list-style-type: none"> <li>- For machining center series An error has been found in axis specification of the tool length measurement function (G37). Alternatively, a move command is specified as an incremental command. Correct the program.</li> <li>- For lathe An error has been found in axis specification of the automatic tool compensation function (G36, G37). Alternatively, a command is specified as an incremental command. Correct the program.</li> </ul>
0085	OVERRUN ERROR	<p>The next character was received from the I/O device connected to reader/punch interface 1 before it could read a previously received character.</p> <p>An overrun, parity error, or framing error occurred during the reading by reader/punch interface 1. The number of bits in the entered data, the baud rate setting, or the I/O unit specification number is incorrect.</p>
0086	DR OFF	During I/O process by reader/punch interface 1, the data set ready input signal of the I/O device (DR) was OFF. Possible causes are an I/O device not turn on, a broken cable, and a defective printed circuit board.
0087	BUFFER OVERFLOW	During a read by reader/punch interface 1, although a read stop command was issued, more than 10 characters were input. The I/O device or printed circuit board was defective.
0090	REFERENCE RETURN INCOMPLETE	<ol style="list-style-type: none"> <li>1. The reference position return cannot be performed normally because the reference position return start point is too close to the reference position or the speed is too slow. Separate the start point far enough from the reference position, or specify a sufficiently fast speed for reference position return.</li> <li>2. An attempt was made to set the zero position for the absolute position detector by return to the reference position when it was impossible to set the zero point. Rotate the motor manually at least one turn, and set the zero position of the absolute position detector after turning the CNC and servo amplifier off and then on again.</li> </ol>
0091	MANUAL REFERENCE POSITION RETURN IS NOT PERFORMED IN FEED HOLD	Manual return to the reference position cannot be performed when automatic operation is halted. Perform the manual return to the reference position when automatic operation is stopped or reset.
0092	ZERO RETURN CHECK (G27) ERROR	The axis specified in G27 has not returned to zero. Reprogram so that the axis returns to zero.
0094	P TYPE NOT ALLOWED (COORD CHG)	P type cannot be specified when the program is restarted. (After the automatic operation was interrupted, the coordinate system setting operation was performed.) Perform the correct operation according to the Operator's Manual.
0095	P TYPE NOT ALLOWED (EXT OFS CHG)	P type cannot be specified when the program is restarted. (After the automatic operation was interrupted, the external workpiece offset amount changed.) Perform the correct operation according to the Operator's Manual.
0096	P TYPE NOT ALLOWED (WRK OFS CHG)	P type cannot be specified when the program is restarted. (After the automatic operation was interrupted, the workpiece offset amount changed.) Perform the correct operation according to the Operator's Manual.

Number	Message	Description
0097	P TYPE NOT ALLOWED (AUTO EXEC)	P type cannot be directed when the program is restarted. (After power ON, after emergency stop or alarms 0094 to 0097 reset, no automatic operation is performed.) Perform automatic operation.
0098	G28 FOUND IN SEQUENCE RETURN	A command of the program restart was specified without the reference position return operation after power ON or emergency stop, and G28 was found during search. Perform the reference position return.
0099	MDI EXEC NOT ALLOWED AFT. SEARCH	After completion of search in program restart, a move command is given with MDI.
0109	FORMAT ERROR IN G08	A value other than 0 or 1 was specified after P in the G08 code, or no value was specified.
0110	OVERFLOW :INTEGER	An integer went out of range during arithmetic calculations.
0111	OVERFLOW :FLOATING	A decimal point (floating point number format data) went out of range during arithmetic calculations.
0112	ZERO DIVIDE	An attempt was made to divide by zero in a custom macro.
0113	IMPROPER COMMAND	A function which cannot be used in custom macro is commanded. Modify the program.
0114	ILLEGAL EXPRESSION FORMAT	The format used in an expression in a custom macro statement is in error. The parameter tape format is in error.
0115	VARIABLE NO. OUT OF RANGE	A number that cannot be used for a local variable, common variable, or system variable in a custom macro is specified. In the EGB axis skip function (G31.8), a non-existent custom macro variable number is specified. Or, the number of custom macro variables used to store skip positions is not sufficient. Alternatively, the header data in high-speed cycle machining is improper. This alarm is issued in the following cases. <ol style="list-style-type: none"> <li>1) The header corresponding to the specified call machining cycle number is absent.</li> <li>2) The value of cycle connection information falls outside the allowable range (0 to 999).</li> <li>3) The number of data items in the header falls outside the allowable range (1 to 65535).</li> <li>4) The storage start data variable number of executable data falls outside the allowable ranges (#20000 to #85535/#200000 to #986431/#200000 to #3999999).</li> <li>5) The storage end data variable number of executable data falls outside the allowable ranges (#85535/#986431/#3999999).</li> <li>6) The storage start data variable number of executable data is the same as the variable number used by the header.</li> </ol>
0116	WRITE PROTECTED VARIABLE	An attempt was made in a custom macro to use on the left side of an expression a variable that can only be used on the right side of an expression.
0118	TOO MANY BRACKET NESTING	Too many brackets "[ ]" were nested in a custom macro. The nesting level including function brackets is 5.
0119	ARGUMENT VALUE OUT OF RANGE	The value of an argument in a custom macro function is out of range.
0122	TOO MANY MACRO NESTING	Too many macro calls were nested in a custom macro.
0123	ILLEGAL MODE FOR GOTO/WHILE/DO	A GOTO statement or WHILE-DO statement was found in the main program in the MDI or DNC mode.
0124	MISSING END STATEMENT	The END instruction corresponding to the DO instruction was missing in a custom macro.
0125	MACRO STATEMENT FORMAT ERROR	The format used in a macro statement in a custom macro is in error.

Number	Message	Description
0126	ILLEGAL LOOP NUMBER	DO and END Nos. in a custom macro are in error, or exceed the permissible range (valid range: 1 to 3).
0127	DUPLICATE NC,MACRO STATEMENT	An NC statement and macro statement were specified in the same block.
0128	ILLEGAL MACRO SEQUENCE NUMBER	The specified sequence No. could not be found for sequence number search. The sequence No. specified as the jump destination in GOTO-- and M99P-- could not be found.
0129	USE 'G' AS ARGUMENT	G is used as an argument in a custom macro call. G can be specified as an argument only in an every-block call (G66.1).
0130	NC AND PMC AXIS ARE CONFLICTED	The NC command and the PMC axis control command were conflicted. Modify the program or ladder.
0136	SPOS AXIS - OTHER AXIS SAME TIME	The spindle positioning axis and another axis are specified in the same block.
0137	M-CODE & MOVE CMD IN SAME BLK.	The spindle positioning axis and another axis are specified in the same block.
0138	SUPERIMPOSED DATA OVERFLOW	The total distribution amount of the CNC and PMC is too large during superimposed control for PMC axis control.
0139	CANNOT CHANGE PMC CONTROL AXIS	The PMC axis was selected for the axis for which the PMC axis is being controlled.
0140	PROGRAM NUMBER ALREADY IN USE	In the background, an attempt was made to select or delete the program being selected in the foreground. Perform the correct operation for the background edition.
0141	CAN NOT COMMAND G51 IN 3-D OFFSET	G51 (Scaling ON) is commanded in the 3-dimensional tool compensation mode. Modify the program.
0142	ILLEGAL SCALE RATE	The scaling rate is 0 times or 10000 times or more. Modify the setting of the scaling rate. (G51P_ ... or G51I_ J_ K_ ... or parameter No. 5411 or 5421)
0143	COMMAND DATA OVERFLOW	An overflow occurred in the storage length of the CNC internal data. This alarm is also generated when the result of internal calculation of scaling, coordinate rotation and cylindrical interpolation overflows the data storage. It also is generated during input of the manual intervention amount.
0144	ILLEGAL PLANE SELECTED	The coordinate rotation plane and arc or tool radius-tool nose radius compensation plane must be the same. Modify the program.
0145	ILLEGAL USE OF G12.1/G13.1	The axis No. of plane selection parameter No. 5460 (linear axis) and No. 5461(axis of rotation) in the polar coordinate interpolation mode is out of range (1 to number of controlled axes).
0146	ILLEGAL USE OF G-CODE	The modal G code group contains an illegal G code in the polar coordinate interpolation mode or when a mode was canceled. Only the following G codes are allowed: G40, G50, G69.1 An illegal G code was specified while in the polar coordinate interpolation mode. The following C codes are not allowed: G27, G28, G30, G30.1, G31 to G31.4, G37 to G387.3, G52, G92, G53, G17 to G19, G81 to G89, G68 In the 01 group, G codes other than G01, G02, G03, G02.2 and G03.2 cannot be specified.
0148	SETTING ERROR	Automatic corner override deceleration rate is out of the settable range of judgement angle. Modify the parameters Nos. 1710 to 1714.

Number	Message	Description
0149	FORMAT ERROR IN G10L3	In registration (G10L3 to G11) of tool life management data, an address other than Q1, Q2, P1, and P2 or an unusable address was specified.
0150	ILLEGAL LIFE GROUP NUMBER	The tool group number exceeded the maximum allowable value. The tool group number (P after specification of G10 L3;) or the group number given by the tool life management T code in a machining program.
0151	GROUP NOT FOUND AT LIFE DATA	The tool group specified in a machining program is not set in tool life management data.
0152	OVER MAXIMUM TOOL NUMBER	The number of tools registered in one group exceeded the maximum allowable registration tool number.
0153	T-CODE NOT FOUND	In registration of tool life data, a block in which the T code needs to be specified does not include the T code. Alternatively, in tool exchange method D, M06 is specified solely. Modify the program.
0154	NOT USING TOOL IN LIFE GROUP	<ul style="list-style-type: none"> <li>- For the tool management command H99 or D99 was specified when no tool management data number is assigned to the spindle position. Modify the program.</li> <li>- For the tool life management command The H99 command, D99 command, or the H/D code set by parameters Nos. 13265 and 13266 was specified when no tool belonging to a group is used.</li> </ul>
0155	ILLEGAL T-CODE COMMAND	In the machining program, the T code that is present in the block containing M06 does not correspond to the group currently being used. Modify the program.
0156	P/L COMMAND NOT FOUND	The P and L commands are not specified in the beginning of a program for setting a tool group. Modify the program.
0157	TOO MANY TOOL GROUPS	In registration of tool life management data, the group setting command block counts of P (group number) and L (tool life) exceeded the maximum group count.
0158	TOOL LIFE VALUE OUT OF RANGE	The life value that is being set is too large. Change the setting.
0159	ILLEGAL TOOL LIFE DATA	Tool life management data is corrupted for some reason. Register the tool data in the tool group or the tool data in the group again by G10L3; or MDI input.
0160	MISMATCH WAITING M-CODE	<p>A waiting M-code is in error.</p> <p>&lt;1&gt; When different M codes are specified for path 1 and path 2 as waiting M codes without a P command.</p> <p>&lt;2&gt; When the waiting M codes are not identical even though the P commands are identical</p> <p>&lt;3&gt; When the waiting M codes are identical and the P commands are not identical (This occurs when a P command is specified with binary value.)</p> <p>&lt;4&gt; When the number lists in the P commands contain a different number even though the waiting M codes are identical (This occurs when a P command is specified by combining path numbers.)</p> <p>&lt;5&gt; When a waiting M code without a P command (2-path waiting) and a waiting M code with a P command (3-or-more-path waiting) were specified at the same time</p> <p>&lt;6&gt; When a waiting M code without a P command was specified for 3 or more paths.</p>

Number	Message	Description
0161	ILLEGAL P OF WAITING M-CODE	P in a waiting M-code is incorrect. <1> When address P is negative <2> When a P value inappropriate for the system configuration was specified <3> When a waiting M code without a P command (2-path waiting) was specified in the system having 3 or more paths.
0163	ILLEGAL COMMAND IN G68/G69	G68 and G69 are not independently commanded in balance cut. An illegal value is commanded in a balance cut combination (address P).
0169	ILLEGAL TOOL GEOMETRY DATA	Incorrect tool figure data in interference check. Set correct data, or select correct tool figure data.
0175	ILLEGAL G07.1 AXIS	An axis which cannot perform cylindrical interpolation was specified. More than one axis was specified in a G07.1 block. An attempt was made to cancel cylindrical interpolation for an axis that was not in the cylindrical interpolation mode. For the cylindrical interpolation axis, set not "0" but one of 5, 6 or 7 (parallel axis specification) to parameter No. 1022 to instruct the arc with axis of rotation (bit 1 (ROT) of parameter No. 1006 is set to "1" and parameter No. 1260 is set) ON.
0176	ILLEGAL G-CODE USE(G07.1 MODE)	A G code was specified that cannot be specified in the cylindrical interpolation mode. This alarm also is generated when an 01 group G code was in the G00 mode or code G00 was instructed. Cancel the cylindrical interpolation mode before instructing code G00.
0177	CHECK SUM ERROR (G05)	A checksum error occurred.
0178	ILLEGAL COMMAND G05	The settings of bits 4 to 6 of parameter No.7501 are invalid or G05 was specified in any of the following mode. - Hypothetical axis interpolation (G07) - Cylindrical interpolation (G07.1) - Polar coordinate interpolation (G12.1) - Polar coordinates command (G16) - Spindle speed fluctuation detection (G26) - Tool radius · tool nose radius compensation (G41/G42) - Normal direction control (G41.1/G42.1) - Scaling (G51) - Programmable mirror image (G51.1) - Coordinate system rotation (G68) - Canned cycle (G81 to G89) - Constant surface speed control (G96) - Macro interruption(M96)
0179	PARAM. (NO.7510) SETTING ERROR	The number of controlled axes set by the parameter No. 7510 exceeds the maximum number. Modify the parameter setting value. The distribution of high-speed cycle machining or high-speed binary program operation stopped.
0190	ILLEGAL AXIS SELECTED (G96)	An illegal value was specified in P in a G96 block or parameter No. 5844.
0194	SPINDLE COMMAND IN SYNCHRO-MODE	A Cs contour control mode, spindle positioning command, or rigid tapping mode was specified during the spindle synchronous control mode or simple spindle synchronous control mode.
0197	C-AXIS COMMANDED IN SPINDLE MODE	The program specified a movement along the Cs-axis when the Cs contour control switching signal was off.

Number	Message	Description
0199	MACRO WORD UNDEFINED	Undefined macro word was used. Modify the custom macro.
0200	ILLEGAL S CODE COMMAND	In the rigid tap, an S value was out of range or was not specified. The parameters Nos. 5241 to 5243 setting is an S value which can be specified for the rigid tap. Correct the parameters or modify the program.
0201	FEEDRATE NOT FOUND IN RIGID TAP	The command F code for a cutting feedrate is a zero. If the value of F command is much smaller than that of the S command, when a rigid tap command is specified, this alarm is generated. This is because cutting is not possible by the lead specified by the program.
0202	POSITION LSI OVERFLOW	In the rigid tap, spindle distribution value is too large. (System error)
0203	PROGRAM MISS AT RIGID TAPPING	In the rigid tap, position for a rigid M code (M29) or an S command is incorrect. Modify the program.
0204	ILLEGAL AXIS OPERATION	In the rigid tap, an axis movement is specified between the rigid M code (M29) block and G84 (or G74) block. Modify the program.
0205	RIGID MODE DI SIGNAL OFF	Although a rigid M code (M29) is specified in rigid tapping, the rigid mode DI signal (DGN G061.0) is not ON during execution of the G84 (or G74) block. Check the PMC ladder diagram to find the reason why the DI signal is not turned on.
0206	CAN NOT CHANGE PLANE (RIGID TAP)	Plane changeover was instructed in the rigid mode. Modify the program.
0207	RIGID DATA MISMATCH	The specified distance was too short or too long in rigid tapping.
0210	CAN NOT COMMAND M198/M99	1 The execution of an M198 or M99 command was attempted during scheduled operation. Alternatively, the execution of an M198 command was attempted during DNC operation. Modify the program. 2 The execution of an M99 command was attempted by an interrupt macro during pocket machining in a multiple repetitive canned cycle.
0212	ILLEGAL PLANE SELECT	The direct drawing dimensions programming is commanded for the plane other than the Z-X plane. Correct the program.
0213	ILLEGAL COMMAND IN SYNCHRO-MODE	In feed axis synchronization control, the following errors occurred during the synchronous operation. 1) The program issued the move command to the slave axis. 2) The program issued the manual operation (jog feed or incremental feed) to the slave axis. 3) The program issued the automatic reference position return command without specifying the manual reference position return after the power was turned on. 4) Reference position setting with mechanical stopper was attempted for an axis under axis synchronous control with bit 1 (SFS) of parameter No.7180 = 0. Set bit 1 (SFS) of parameter No.7180 to 1. 5) Reference position setting with mechanical stopper was attempted with the manual handle feed axis select signal selected for the slave axis under axis synchronous control. Select the manual handle feed axis select signal for the master axis under axis synchronous control.
0214	ILLEGAL COMMAND IN SYNCHRO-MODE	Coordinate system is set or tool compensation of the shift type is executed in the synchronous control. Correct the program.
0217	DUPLICATE G51.2(COMMANDS)	G51.2 is further commanded in the G51.2 mode. Modify the program.

Number	Message	Description
0218	NOT FOUND P/Q COMMAND	P or Q is not commanded in the G51.2 block, or the command value is out of the range. Modify the program. For a polygon turning between spindles, more information as to why this alarm occurred is indicated in diagnosis data No. 471.
0219	COMMAND G51.2/G50.2 INDEPENDENTLY	G51.2 and 50.2 were specified in the same block for other commands. Modify the program in another block.
0220	ILLEGAL COMMAND IN SYNCHR-MODE	In the synchronous operation, movement is commanded by the NC program or PMC axis control interface for the synchronous axis. Modify the program or check the PMC ladder.
0221	ILLEGAL COMMAND IN SYNCHR-MODE	Polygon machining synchronous operation and axis control or balance cutting are executed at a time. Modify the program.
0222	DNC OP. NOT ALLOWED IN BG-EDIT	Input and output are executed at a time in the background edition. Execute a correct operation.
0224	ZERO RETURN NOT FINISHED	A reference return has not been performed before the start of automatic operation. (Only when bit 0 (ZRNx) of parameter No. 1005 is 0) Perform a reference position return.
0230	R CODE NOT FOUND	Cut depth R is not specified in the block including G161. Alternatively, the value specified for R is negative. Modify the program.
0231	ILLEGAL FORMAT IN G10 L52	Errors occurred in the specified format at the programmable-parameter input.
0232	TOO MANY HELICAL AXIS COMMAND	Three or more axes were specified as helical axes in the helical interpolation mode. Five or more axes were specified as helical axes in the helical interpolation B mode.
0233	DEVICE BUSY	When an attempt was made to use a unit such as that connected via the RS-232-C interface, other users were using it.
0241	ILLEGAL FORMAT IN G02.2/G03.2	The end point of an involute curve on the currently selected plane, or the center coordinate instruction I, J or K of the corresponding basic circle, or basic circle radius R was not specified.
0242	ILLEGAL COMMAND IN G02.2/G03.2	An illegal value was specified in the involute curve. The coordinate instruction I, J or K of the basic circle on the currently selected plane or the basic circle radius R is "0", or the start and end points are not inside the basic circle.
0243	OVER TOLERANCE OF END POINT	The end point is not positioned on the involute curve that passes through the start point, and this error exceeds the permissible error limit (parameter No. 5610).
0245	T-CODE NOT ALLOWED IN THIS BLOCK	One of the G codes, G50, G10, G04, G28, G28.2, G29, G30, and G30.2,G30.1,G53, which cannot be specified in the same block as a T code, was specified with a T code.
0247	THE MISTAKE IS FOUND IN THE OUTPUT CODE OF DATA.	When an encrypted program is output, EIA is set for the output code. Specify ISO.
0250	TOOL CHANGE ILLEGAL Z AXIS COMMAND	A Z-axis move command was performed in the same block for M06 command.
0251	TOOL CHANGE ILLEGAL T COMMAND	An unusable T code was specified in M06Txx.
0253	G05 CAN NOT BE COMMANDED	A binary operation was specified during advanced preview control mode.

Number	Message	Description
0300	ILLEGAL COMMAND IN SCALING	<p>An illegal G code was specified during scaling. Modify the program. For the T system, one of the following functions is specified during scaling, this alarm is generated.</p> <ul style="list-style-type: none"> <li>- Finishing cycle (G70 or G72)</li> <li>- Outer surface rough-cutting cycle (G71 or G73)</li> <li>- End side rough-cutting cycle (G72 or G74)</li> <li>- Closed loop cutting cycle (G73 or G75)</li> <li>- End side cutting-off cycle (G74 or G76)</li> <li>- Outer surface or inner surface cutting-off cycle (G75 or G77)</li> <li>- Multiple repetitive threading cycle (G76 or G78)</li> <li>- Face drill cycle (G83 or G83)</li> <li>- Face tap cycle (G84 or G84)</li> <li>- Face boring cycle (G85 or G85)</li> <li>- Side drill cycle (G87 or G87)</li> <li>- Side tap cycle (G88 or G88)</li> <li>- Side boring cycle (G89 or G89)</li> <li>- Outer surface turning cycle or inner surface boring cycle (G77 or G20)</li> <li>- Threading cycle (G78 or G21)</li> <li>- End side turning cycle (G79 or G24)</li> </ul> <p>(Specify G codes for systems B and C in that order.)</p>
0301	RESETTING OF REFERENCE RETURN IS INHIBITED	<p>Although bit 0 (IDGx) of parameter No. 1012 was set to 1 to inhibit the reference position from being set again for a return to the reference position without a dog, an attempt was made to perform a manual return to the reference position.</p>
0302	SETTING THE REFERENCE POSITION WITHOUT DOG IS NOT PERFORMED	<p>The reference position could not be set for a return to the reference position without a dog. Possible causes are:</p> <ul style="list-style-type: none"> <li>- The axis was not moved in the direction of a return to the reference position for jog feeding.</li> <li>- The axis was moved in the direction opposite to the direction of a manual return to the reference position.</li> <li>- Since the one-rotation signal of the position detector is not caught, the manual reference position return grid is not established. (Bit 6 of diagnosis data No. 0201 must be set to 1.)</li> </ul>
0303	REFERENCE POSITION RETURN IS NOT PERFORMED	<p>When the setting of a reference position at any position was possible in Cs contour control (bit 0 (CRF) of parameter No. 3700 = 1), a G00 command was issued for the Cs contour axis without a return to the reference position after the serial spindle was switched to Cs contour control mode. Perform a reference position return with a G28 command before issuing a G00 command.</p>
0304	G28 IS COMMANDED WITHOUT ZERO RETURN	<p>Although a reference position was not set, an automatic return to the reference position (G28) was commanded.</p>
0305	INTERMEDIATE POSITION IS NOT ASSIGNED	<p>Although a G28 (automatic return to the reference position), G30 (return to the second, third, or fourth reference position), or G30/1 (return to the floating reference position) command was not issued after power-up, G29 (return from the reference position) was commanded.</p>
0306	MISMATCH AXIS WITH CNR/CHF	<p>The correspondence between the moving axis and the I, J, or K command is incorrect in a block in which chamfering is specified.</p>
0307	CAN NOT START REFERENCE RETURN WITH MECHANICAL STOPPER SETTING	<p>Reference position setting with mechanical stopper is being attempted for an axis which uses the "reference position setting without dog" function.</p>



Number	Message	Description
0308	G72.1 NESTING ERROR	G72.1 was specified again during G72.1 rotation copying.
0309	G72.2 NESTING ERROR	G72.2 was specified again during G72.2 parallel copying.
0310	FILE NOT FOUND	The specified file could not be found during a subprogram or macro call.
0311	CALLED BY FILE NAME FORMAT ERROR	An invalid format was specified to call a subprogram or macro using a file name.
0312	ILLEGAL COMMAND IN DIRECT DRAWING DIMENSIONS PROGRAMMING	Direct input of drawing dimensions was commanded in an invalid format. An attempt was made to specify an invalid G code during direct input of drawing dimensions. Two or more blocks not to be moved exist in consecutive commands that specify direct input of drawing dimensions. Although non-use of commas (,) (bit 4 of parameter No. 3405 = 1) was specified for direct input of drawing dimensions, a comma was specified.
0313	ILLEGAL LEAD COMMAND	The variable-lead threading increment specified in address K exceeds the specified maximum value in variable-lead threading. Or, a negative lead value was specified.
0314	ILLEGAL SETTING OF POLYGONAL AXIS	An axis was specified invalidly in polygon turning. For polygon turning: A tool rotation axis is not specified. (Parameter No. 7610) For polygon turning between spindles: Valid spindles are not specified. (Parameters Nos. 7640 to 7643) - A spindle other than the serial spindle. - A spindle is not connected. For concurrent use of polygon turning and polygon turning with two spindles: - In the polygon turning mode, the value of parameter No. 7605 (selecting the type of polygon turning) was changed. - An attempt is made to use a spindle used for polygon turning also for polygon turning with two spindles.
0315	ILLEGAL NOSE ANGLE COMMAND IS IN THE THREAD CUTTING CYCLE	An invalid tool tip angle is specified in a multiple repetitive canned threading cycle (G76).
0316	ILLEGAL CUTTING AMOUNT IS IN THE THREAD CUTTING CYCLE	A minimum depth of cut higher than the thread height is specified in a multiple repetitive canned threading cycle (G76).
0317	ILLEGAL THREAD COMMAND IS IN THE THREAD CUTTING CYCLE	A zero or a negative value is specified in a multiple repetitive canned threading cycle (G76) as the thread height or the depth of cut.
0318	ILLEGAL RELIEF AMOUNT IS IN THE DRILLING CYCLE	Although an escape directions is set in a multiple repetitive canned cutting-off cycle (G74 or G75), a negative value is specified for $\Delta d$ .
0319	THE END POINT COMMAND IS ILLEGAL IN THE DRILLING CYCLE	Although the $\Delta i$ or $\Delta k$ travel distance is set to 0 in a multiple repetitive canned cutting-off cycle (G74 or G75), a value other than 0 is specified for a U or W.
0320	ILLEGAL MOVEMENT AMOUNT/CUTTING AMOUNT IS IN THE DRILLING CYCLE	A negative value is specified in a multiple repetitive canned cutting-off cycle (G74 or G75) as $\Delta i$ or $\Delta k$ (travel distance/the depth of cut).
0321	ILLEGAL REPEATED TIME IS IN THE PATTERN REPEATING CYCLE	A zero or a negative value is specified in a multiple repetitive canned closed loop cycle (G73) as a repeated time.
0322	FINISHING SHAPE WHICH OVER OF STARTING POINT	An invalid shape which is over the cycle starting point is specified in a shape program for a multiple repetitive canned rough-cutting cycle (G71 or G72).

Number	Message	Description
0323	THE FIRST BLOCK OF SHAPE PROGRAM IS A COMMAND OF TYPE II	Type II is specified in the first block of the shape program specified by P in a multiple repetitive canned rough-cutting cycle (G71 or G72). Z (W) command is for G71. X (U) command is for G72.
0324	THE INTERRUPTION TYPE MACRO WAS DONE IN THE MULTIPLE REPETITIVE CYCLES	An interruption type macro was issued during the multiple repetitive canned cycle (G70, G71, G72, or G73).
0325	UNAVAILABLE COMMAND IS IN SHAPE PROGRAM	An usable command was issued in a shape program for a multiple repetitive canned cycle (G70, G71, G72, or G73).
0326	LAST BLOCK OF SHAPE PROGRAM IS A DIRECT DRAWING DIMENSIONS	In a shape program in the multiple repetitive canned cycle (G70, G71, G72, or G73), a command for direct input of drawing dimensions in the last block is terminated in the middle.
0327	MODAL THAT MULTIPLE REPETITIVE CYCLES CANNOT BE DONE	A multiple repetitive canned cycle (G70, G71, G72, or G73) was commanded in a modal state in which a multiple repetitive canned cycle could not be commanded.
0328	ILLEGAL WORK POSITION IS IN THE TOOL NOSE RADIUS COMPENSATION	The specification for the blank side for a tool nose radius compensation (G41 or G42) is incorrect in a multiple repetitive canned cycle (G71 or G72).
0329	THE FINISHING SHAPE IS NOT A MONOTONOUS CHANGE(SECOND AXES)	In a shape program for the multiple repetitive canned rough-cutting cycle (G71 or G72), the command of the second plane axis was not a monotonous increase or decrease.
0330	ILLEGAL AXIS COMMAND IS IN THE TURNING CANNED CYCLE	An axis other than the plane is specified in a canned cycle(G90, G92, or G94).
0331	ILLEGAL AXIS NUMBER IN AX[]	An illegal value is specified for an AX[] axis number.
0332	ILLEGAL AXIS ADDRESS IN AXNUM[]	An illegal value is specified for an AXNUM[] axis address.
0333	TOO MANY SPINDLE COMMANDS	Multiple spindle commands could be found in the same block in using an expansion spindle name. Only one spindle could be commanded in the same block.
0334	INPUT VALUE OUT OF EFFECTIVE RANGE	An offset data which was out of the effective range was specified. (malfunction prevention function)
0335	PLURAL M CODE	Multiple M codes are commanded simultaneously in a block for a wait function with peripheral devices by an M code.
0336	TOOL COMPENSATION COMMANDED MORE TWO AXES	For a tool length compensation C, an attempt was made to command the offset to other axes without canceling the offset. Or, for a tool length compensation C, multiple axes are specified in G43 or G44 block.
0337	EXCESS MAXIMUM INCREMENTAL VALUE	The command value exceeded the maximum amount of incremental. (malfunction prevention function)
0340	ILLEGAL RESTART(NANO SMOOTHING)	With manual absolute turned on, an attempt was made to restart the operation in nano smoothing mode after performing the manual interaction.
0341	TOO MANY COMMAND BLOCK (NANO SMOOTHING)	There are more blocks than can be commanded consecutively in nano smoothing mode.
0342	CUSTOM MACRO INTERRUPT ENABLE IN NANO SMOOTHING	A custom macro interrupt was enabled in nano smoothing mode. Or, nano smoothing mode was commanded with a custom macro interrupt enabled.
0343	ILLEGAL COMMAND IN NANO SMOOTHING	G43, G44, or G49 was commanded during a nano smoothing.
0344	CANNOT CONTINUE NANO SMOOTHING	An illegal command or operation by which a nano smoothing could not be continued was performed.
0345	TOOL CHANGE ILLEGAL Z AXIS POS	A tool change position on the Z-axis is incorrect.

Number	Message	Description
0346	TOOL CHANGE ILLEGAL TOOL NUM	A tool change position is not set.
0347	TOOL CHANGE ILLEGAL COMMAND IN SAME BLK.	Tool changing is commanded twice or more in the same block.
0348	TOOL CHANGE Z AXIS POS NOT ESTABLISHED	A tool change spindle on the Z-axis is not set.
0349	TOOL CHANGE SPINDLE NOT STOP	A tool change spindle stop is not stopped.
0350	PARAMETER OF THE INDEX OF THE SYNCHRONOUS CONTROL AXIS SET ERROR.	An illegal synchronization control axis number (parameter No. 8180) is set.
0351	BECAUSE THE AXIS IS MOVING, THE SYNC CONTROL IS CAN'T BE USED.	While the axis being subject to synchronization control was moving, an attempt was made to start or cancel the synchronization control by a synchronization control axis selection signal.
0352	SYNCHRONOUS CONTROL AXIS COMPOSITION ERROR.	This error occurred when: 1) An attempt was made to perform synchronization control for the axis during a synchronization, composition, or superposition. 2) An attempt was made to synchronize a further great-grandchild for a parent-child-grandchild relation. 3) An attempt was made to operate synchronization control although a parent-child-grandchild relation was not set.
0353	THE INSTRUCTION WAS DONE FOR THE AXIS WHICH WAS NOT ABLE TO MOVE.	This error occurred when: - For synchronization 1) A move command was issued to the axis for which bit 7 (NUMx) of parameter No. 8163 is set to 1. 2) A move command was issued to the slave axis. - For composition 1) A move command was issued to the axis for which bit 7 (NUMx) of parameter No. 8163 is set to 1. 2) A move command was issued to the axis for which bit 7 (MUMx) of parameter No. 8162 is set to 1.
0354	THE G28 WAS INSTRUCTED IN WITH THE REF POS NOT FIXED IN SYNC MODE	This error occurred when G28 was specified to the master axis being parking during synchronization control, but an axis reference position is not set for the slave axis.
0355	PARAMETER OF THE INDEX OF THE COMPOSITE CONTROL AXIS SET ERROR.	An illegal composite control axis number (parameter No. 8183) is specified.
0356	BECAUSE THE AXIS IS MOVING, THE COMP CONTROL IS CAN'T BE USED.	While the axis being subject to composite control was moving, an attempt was made to start or cancel the composite control by a composite control axis selection signal.
0357	COMPOSITE CONTROL AXIS COMPOSITION ERROR.	This error occurred when an attempt was made to perform composite control for the axis during a synchronization, composition, or superposition.
0359	THE G28 WAS INSTRUCTED IN WITH THE REF POS NOT FIXED IN COMP MODE	This error occurred when G28 was specified to the composite axis during composite control, but a reference position is not set to the other part of the composition.
0360	PARAMETER OF THE INDEX OF THE SUPERPOS CONTROL AXIS SET ERROR.	An illegal superposition control axis number (parameter No. 8186) is specified.
0361	BECAUSE THE AXIS IS MOVING, THE SUPERPOS CONTROL IS CAN'T BE USED.	While the axis being subject to superposition control was moving, an attempt was made to start or cancel the superposition control by a superposition control axis selection signal.

Number	Message	Description
0362	SUPERPOSITION CONTROL AXIS COMPOSITION ERROR.	This error occurred when: 1) An attempt was made to perform superposition control for the axis during a synchronization, composition, or superposition. 2) An attempt was made to synchronize a further great-grandchild for a parent-child-grandchild relation.
0363	THE G28 WAS INSTRUCTED IN TO THE SUPERPOS CONTROL SLAVE AXIS.	This error occurred when G28 was specified to the superposition control slave axis during superposition control.
0364	THE G53 WAS INSTRUCTED IN TO THE SUPERPOS CONTROL SLAVE AXIS.	This error occurred when G53 was specified to the slave axis being moved during superposition control.
0365	TOO MANY MAXIMUM SV/SP AXIS NUMBER PER PATH	The maximum control axis number or maximum control spindle number which could be used within a path was exceeded. (For a loader path, this alarm is generated if the number of axis per path is set to 5 or greater.)
0366	IMPROPER G-CODE IN TURRET METHOD	When the turret change tools method was selected (bit 3 (TCT) of parameter No. 5040 = 0), G43, G43.1, G43.4, G43.5, or G43.7 was commanded.
0367	3-D CONV. WAS COMMANDED IN SYNC MODE AS THE PARAMETER PKUx(NO.8162#2) IS 0.	A three-dimensional coordinate conversion was commanded during synchronization control when the bit 2 (PKUx) of parameter No. 8162 was 0.
0368	OFFSET REMAIN AT OFFSET COMMAND	- When the ATC change tools method was selected (bit 3 (TCT) of parameter No. 5040 = 1) during G43, G43.1, G43.4, or G43.5 mode, G43.7 was commanded. Or, G43, G43.1, G43.4, or G43.5 was commanded during G43.7 mode. - After bit 3 (TCT) of parameter No. 5040 was changed in the state in which a tool offset remained, another tool offset was specified.
0369	G31 FORMAT ERROR	- No axis is specified or tow or more axes are specified in the torque limit switch instruction (G31P98/P99). - The specified torque Q value in the torque limit switch instruction is out of range. The torque Q range is 1 to 254. - The high-speed continuous skip option is not present.
0370	G31P/G04Q ERROR	1) The specified address P value for G31 is out of range. The address P range is 1 to 4 in a multistage skip function. 2) The specified address Q value for G04 is out of range. The address Q range is 1 to 4 in a multistage skip function. 3) P1-4 for G31, or Q1-4 for G04 was commanded without a multistage skip function option. 4) <T series > The specified value of address P of G72 or G74 falls outside the range. Address P ranges from 1 to 4 in the multistage skip function. P1-4 was specified in G72 or G74 even though the multistage skip function option is not present.
0371	ILLEGAL FORMAT IN G10 OR L50	In a command format for a programmable parameter input, an attempt was made to change the parameter for an encryption (No. 3220), key (No. 3221), or protection range (No.3222 or No.3223) as a "the encryption function for the key and program." Modify the program.

Number	Message	Description
0372	REFERENCE RETURN INCOMPLETE	An attempt was made to perform an automatic return to the reference position on the orthogonal axis before the completion of a return to the reference position on the angular axis. However, this attempt failed because a manual return to the reference position during angular axis control or an automatic return to the reference position after power-up was not commanded. First, return to the reference position on the angular axis, then return to the reference position on the orthogonal axis.
0373	ILLEGAL HIGH-SPEED SKIP SIGNAL	In the skip commands (G31, G31P1 to G31P4) and dwell commands (G04, G04Q1 to G04Q4), the same high-speed signal is selected in different paths.
0374	ILLEGAL REGISTRATION OF TOOL MANAGER(G10)	G10L75 or G10L76 data was registered during the following data registration: - From the PMC window. - From the FOCAS2. - By G10L75 or G10L76 in another system. Command G10L75 or G10L76 again after the above operation is completed.
0375	CAN NOT ANGULAR CONTROL(SYNC:MIX:OVL)	Angular axis control is disabled for this axis configuration. 1) When some related axes under angular axis control are not in synchronous control mode or when one angular axis is not paired with the other angular axis or one Cartesian axis is not paired with the other Cartesian axis in synchronous control 2) When some related axes under composite control are not in composite control mode or when one angular axis is not paired with the other angular axis or one Cartesian axis is not paired with the other Cartesian axis in composite control 3) When related axes under angular axis control is switched to superposition control mode1)
0376	SERIAL DCL: ILLEGAL PARAMETER	1. When bit 1 of parameter No. 1815 is set to "1", bit 3 of parameter No. 2002 is set to "0" 2. The absolute-position detection function is enabled. (Bit 5 of parameter No. 1815 is set to "1".)
0387	ILLEGAL RTM DI/DO VAR	There is no DI/DO variable that has a specified signal address (alphabet, number).
0389	ILLEGAL RTM SIGNAL BIT	Bits other than bits 0 to 7 cannot be specified with a DI/DO signal.
0390	ILLEGAL MACRO VAR	A macro variable which was not supported by the real time custom macro function was used.
0391	RTM BRANCH OVER	The number of branches supported with real time custom macros was exceeded.
0392	TOO MANY SENTENCE CONTROL	Many reserved words (ZONCE, ZEDGE, ZWHILE, ZDO, ZEND, G65, M99) for RTM control were used in a real time macro command.
0393	NO SENTENCE CONTROL	In a real time macro command, there is no data to be assigned.
0394	ILLEGAL SENTENCE CONTROL	The matching of reserved words (ZONCE, ZEDGE, ZWHILE, ZDO, ZEND, G65, M99) for RTM control is incorrect.
0395	ILLEGAL NC WORD CONTROL	Control code G65 or M99 for calling a subprogram or returning from a subprogram is not coded correctly.
0396	ILLEGAL RTM SENTENCE CONTROL	In other than a real time macro command, a reserved word (ZONCE, ZEDGE, ZWHILE, ZDO, or ZEND) for RTM control is used.

Number	Message	Description
0397	RTM BUFFER OVER	There is no buffer available for real time macro commands. Too many blocks read in advance are buffered as triggers used by real time macro commands.
0398	'ID OVER IN BUFFER	In blocks read in advance, there are too many real time macro commands with the same ID.
0399	'ID EXECUTION IN SAME TIME	An attempt was made to execute real time macro commands with the same ID by using the same NC statement as a trigger.
0400	ONESHOT CMDOVER	Too many one-shot real time macro commands are specified.
0401	EXEC CMD NUM OVER IN SAME TIME	The number of real time macro commands that can be executed simultaneously was exceeded
0402	ILLEGAL TOKEN FOR RTM	A token, variable, or function that is not supported by the real time custom macro function was detected.
0403	ACCESS TO RTM PROTECT VAR	An attempt was made to access a protected variable.
0404	RTM ERROR	An error related to a real time macro command occurred.
0406	CODE AREA SHORTAGE	The storage size of the real time macro area is insufficient.
0407	DOULE SLASH IN RTM MODE	In the compile mode, an attempt was made to set the compile mode again.
0408	G90 IS NOT PERMITTED	The absolute command cannot be specified.
0409	ILLEGAL AXIS NO	An invalid axis number is specified.
0410	MIDDLE POINT IS NOT ZERO	An intermediate point other than 0 is specified with G28.
0411	SIMULTANEOUSLY AXES OVER	The maximum number of axes that can be controlled simultaneously was exceeded.
0412	ILLEGAL G CODE	An unusable G code was used.
0413	ILLEGAL ADDRESS	An unusable address was used.
0414	ILLEGAL PMC AXIS NO.	An invalid PMC axis number is specified.
0415	GROUP IS IN USE	The group to which the specified axis belongs is already in used.
0416	UNABLE TO USE THE AXIS	The specified axis cannot be used.
0417	AXIS IS UNABLE TO MOVE	The specified axis is placed in the inoperative state.
0418	ILLEGAL FEED SETTING	An incorrect feedrate is set.
0419	ILLEGAL DISTANCE SETTING	A travel distance beyond the specifiable range is specified.
0420	CONSTANT NUMBER P	A subprogram is specified not by using a constant.
0421	ILLEGAL ARGUMENT G54	With G65, an invalid argument, L, is used.
0422	ILLEGAL ARGUMENT G54	With G65, an invalid argument is used.
0423	NO PMC AXIS CONTROL OPTION	The option for PMC axis control is missing.
0424	MULTIPLE AXES IN ONE GROUP	Multiple axes are using one group.
0425	ONE AXIS USE MULTIPLE GROU	One axis is using multiple groups.
0429	ILLEGAL COMMAND IN G10.6	When retract was started in a threading block, a retract command had been issued for the long axis direction of threading.
0430	TOOL LIFE PAIRS ZERO	Tool life management group number parameter No.6813 is 0.
0431	ILLEGAL T/R DATA OF TOOL LIFE	The arbitrary group number (T) or remaining amount setting (R) is invalid.
0432	UNAVAILABLE POSTURE IN TPC	<ul style="list-style-type: none"> <li>- A tool posture that cannot be assumed under tool posture control was specified. Check the machine configuration and specification.</li> <li>- A command that changes the direction of the tool posture in relation to the interpolation plane was specified in circular interpolation or helical interpolation during tool posture control. Check the machine configuration and the command.</li> </ul>

Number	Message	Description
0436	ILLEGAL PARAMETER IN WSC	<p>An incorrect parameter was specified in compensation of workpiece placement error.</p> <ul style="list-style-type: none"> <li>- The basic three axes are not specified in parameter No.1022.</li> </ul>
0437	ILLEGAL COMMAND IN WSC	<p>An invalid command related to compensation of workpiece placement error was specified.</p> <ul style="list-style-type: none"> <li>- An illegal G code was specified in the workpiece placement error compensation mode.</li> <li>- There is an error in the modal setting used when the compensation of workpiece placement error is started.</li> <li>- G54.4 was not specified solely.</li> <li>- There is not the P command in the block including the G54.4 command. Alternatively, the value following P is out of the range.</li> <li>- Compensation of workpiece placement error was specified redundantly.</li> </ul>
0438	ILLEGAL PARAMETER IN TOOL DIRC CMP	<p>If, on a 5-axis machine, either of the two cases below applies, a parameter is illegal.</p> <p>&lt;1&gt; The setting is such that tool direction compensation is performed if workpiece setting error compensation is performed (bit 0 (RCM) of parameter No. 11200 = 1).</p> <p>&lt;2&gt; Tool center point retention type tool axis direction control (G53.6) is performed.</p> <ul style="list-style-type: none"> <li>- Acc./Dec. before interpolation is disabled. Set parameter No. 1660.</li> <li>- Acc./Dec. before rapid traverse interpolation is disabled. Set bit 1 of parameter No. 1401, bit 5 of parameter No. 1950, and parameter No. 1671.</li> <li>- The parameters Nos.19680 to No.19714 for configuring the machine are incorrect.</li> <li>- The axis set by parameters Nos. 19681 and 19686 is not a rotation axis.</li> <li>- The basic three axes are not set in parameter No. 1022.</li> <li>- In tool length compensation during workpiece setting error compensation, bit 6 (TOS) of parameter No. 5006 is 0 and bit 2 (TOP) of parameter No. 11400 is 0. Set either parameter to 1.</li> </ul>
0439	ILLEGAL COMMAND IN TOOL DIRC CMP	<p>When compensation of workpiece placement error was performed in a 5-axis cutting machine (compensation in the tool direction (bit 0 (RCM) of parameter No. 11200 is 0)), an illegal command was issued.</p> <ul style="list-style-type: none"> <li>- An unspecifiable G code was specified.</li> <li>- There is an error in the modal setting used during startup.</li> <li>- An axis not related to 5-axis machining was specified.</li> <li>- The absolute coordinates of a rotation axis could not be obtained in the startup block of compensation of workpiece placement error or tool center point control.</li> </ul>
0441	DUPLICATE PATH TABLE	<p>The same Path Table numbers exist.</p> <p>Example)</p> <p>&lt;AXIS_TABLE_1234_X1&gt; and &lt;TIME_TABLE_1234_X1&gt; exist.</p> <p>&lt;AXIS_TABLE_0001_M&gt; and &lt;TIME_TABLE_0001_M&gt; exist.</p>

Number	Message	Description
0442	PATH TABLE COMMAND EXCES ERR	<ol style="list-style-type: none"> <li>At the start of the Path Table Operation, the difference between the actual axis position and the start command at the Path Table exceeds the parameter No.11101.</li> <li>At the start of the Path Table Operation, the difference between the actual spindle speed and the start command of spindle speed at the Path Table exceeds the parameter No.11102.</li> </ol>
0443	PTRDY SIGNAL IS OFF	Even though the Path Table Ready signal PTRDY <Fn519.6> is "0", the Path Table Operation is started. Retry Path Table Operation after Path Table conversion.
0444	ILLEGAL PATH TABLE M-CODE	M/P/Q code for starting the Path Table operation is not correct.
0445	ILLEGAL AXIS OPERATION	The positioning command was issued in the speed control mode. Check the SV speed control mode in-progress signal.
0446	ILLEGAL COMMAND IN G96.1/G96.2/G96.3/G96.4	G96.1, G96.2, G96.3, and G96.4 are specified in the block that includes other commands. Modify the program.
0447	ILLEGAL SETTING DATA	The live tool axis is incorrectly set. Check the parameter for spindle control with servo motor.
0451	ILLEGAL AUXILIARY FUNCTION TABLE COMMAND	When M code is output, the ladder of the PMC does not execute the completion processing of the previous M code.
0452	ILLEGAL PATH TABLE OPERATION	<p>In Path Table Operation, the following problems occurred.</p> <ul style="list-style-type: none"> <li>- Skip command is not correct.</li> <li>- The connection of the Path Table is not correct.</li> <li>- Path Table Operation is not correct for other reason.</li> </ul> <p>etc.</p> <p>The detail alarm number is read by using the cnc_rdpdexdistalm function.</p> <p>The detail alarm number can be read by using the C Language Executor or FOCAS2 cnc_rdpdexdistalm function.</p> <p>For details of cnc_rdpdexdistalm function, refer to "CNC/PMC window library" in "C Language Executor Programming Manual (B-63943EN-3).</p>
0455	ILLEGAL COMMAND IN GRINDING	<p>In grinding canned cycles:</p> <ol style="list-style-type: none"> <li>&lt;M series&gt; The signs of the I, J, and K commands do not match.</li> <li>&lt;M series/T series &gt; The amount of travel of the grinding axis is not specified.</li> </ol>
0456	ILLEGAL PARAMETER IN GRINDING	<p>Parameters related to grinding canned cycles are incorrectly set. Probable causes are given below.</p> <ol style="list-style-type: none"> <li>&lt;M series/T series&gt; The axis number of the grinding axis is incorrectly set (parameters Nos. 5176 to 5179).</li> <li>&lt;M series&gt; The axis number of the dressing axis is incorrectly set (parameters Nos. 5180 to 5183).</li> <li>&lt;M series/T series&gt; The axis numbers of the cut axis, grinding axis, and dressing axis (only for the M series) overlap.</li> </ol>
0459	ALL PARALLEL AXES IN PARKING	All the axes specified during automatic operation are parking.
0460	ILLEGAL TORCH AXIS NUMBER	The axis number set in parameter No. 5490 (torch control axis) exceeds the number of control axes.
0461	ILLEGAL SETTING OF ROTATE AXIS FOR TORCH	The parameter setting (bit 0 of parameter No. 1006 = 1) of the rotation axis is not applied to the torch turning axis.
0492	3DCHK FIG. ILLEGAL: [Target name]	The figure data of [Target name] specified for the built-in 3D interference check is invalid.
0493	3DCHK AXIS ILLEGAL: [Target name]	The move axis data of [Target name] specified for the built-in 3D interference check is invalid.



Number	Message	Description
0494	3DCHK FUNCTION INVALID	The 3D interference check function is disabled by bit 0 (ICE) of parameter No. 10930.
0495	3DCHK TOO MANY FIGURE	The total number of shapes included in all interference check targets except the tool exceeds 23.
0496	ILLEGAL P,Q COMMAND IN G22.2	As for G22.2 command, parameter P or Q is out of range or not specified. Please correct G22.2 command.
0497	CANNOT MAKE TOOL FIGURE BY TOOL MANAGEMENT	According to bit 2 (ICT) of parameter No.10930, though the tool figure should be automatically made by using the tool management function, the option for the tool management function is not available.
0501	THE COMMANDED M-CODE CAN NOT BE EXECUTED	The M code specified in parameter No. 11631 to 11646 was specified in other than an execution macro, macro interrupt, macro call using a G or M code, or subprogram call using a T, S, or second auxiliary function code.
0502	ILLEGAL G-CODE	1) A G code unavailable in the inter-path flexible synchronous mode was specified. 2) A G code unavailable in the advanced superimposition state was specified.
0503	ILLEGAL MODAL IN SUPERIMPOSED MODE	Modal state of a G code that cannot be superimposed.
0507	ILLEGAL PARAMETER(NO.7526)	The address of the R signal for the high-speed cycle machining operation information output function is invalid. 1) The specified R signal address is invalid. 2) The start address is not a multiple of 4 (0, 4, 8, ...). 3) A 36-byte area is not allocated.
0508	G code to need G90(PAC)	In parallel axis control, a G code requiring an absolute command (G90) in the block immediately before was specified.
0509	TOOL OFFSET COMMAND IS NOT AVAILABLE	- Tool offset (for the lathe system) was specified in the thread cutting block. - Tool offset was specified (lathe system) in the scaling mode, coordinate system rotation mode, or programmable mirror image mode.
0511	CS HI-SPEED SWITCHING FORMAT ERROR	The format of Cs contour control high speed switching is invalid.
0512	IMPOSSIBLE COMMAND FOR CS HI-SPEED SWITCHING	The following commands cannot be specified in Cs contour control high speed switching: - Move command not for high-speed cycle machining - Synchronous/composite control, superimposed control - Simple spindle synchronous control - Simple spindle electronic gear box - Manual reference position return
0513	CS HI-SPEED SWITCHING SETTING ERROR	The setting for Cs contour control high speed switching is invalid. Possible causes are: - An M code value for Cs contour control high speed switching is used for multiple Cs contour control axes. - FIN is returned for the M code for high-speed switching of Cs contour control when the Cs contour control high speed switching completion signal CSMCx does not become 1. - The spindle software does not support the spindle control switching function for high-speed cycle machining.

Number	Message	Description
0514	ILLEGAL COMMAND IN FLEXIBLE PATH AXIS ASSIGNMENT	<ol style="list-style-type: none"> <li>1) An assignment command in flexible path axis assignment was issued for an axis yet to be removed.</li> <li>2) The P, Q, R, I, J, K, or L value specified by G52.1, G52.2, or G52.3 is invalid.</li> <li>3) The value of the parameter No. 11560 is duplicated.</li> <li>4) An attempt was made to execute a removal command (G52.1) for an axis already removed.</li> <li>5) An attempt was made to exchange axes having different settings of bit 1 (FAN) of parameter No. 11562.</li> <li>6) An attempt was made to perform flexible path axis assignment without canceling the offset.</li> </ol>
0515	ILLEGAL FORMAT IN SMOOTH TCP(G43.4L1)	<p>An illegal command was specified in smooth TCP.</p> <ul style="list-style-type: none"> <li>• An illegal command was specified in a smooth TCP start block. <ul style="list-style-type: none"> <li>- An invalid value was specified with address "L". A value other than 0 and 1 was specified with address "L".</li> <li>- G10.8 was specified at the same time.</li> </ul> </li> </ul>
0516	ILLEGAL PARAMETER IN SMOOTH TCP(G43.4L1)	<p>A parameter related to smooth TCP is illegal.</p> <ul style="list-style-type: none"> <li>• On a machine whose axis configuration is table rotation type or composite type, when the setting was such that the workpiece coordinate system was used as the programming coordinate system (bit 5 (WKP) of parameter No.19696 = 1), smooth TCP was specified</li> <li>• On a machine whose axis configuration is table rotation type or composite type, address "L" was omitted in a TCP start block when the setting was such that smooth TCP would start if address "L" was omitted in the TCP start block (bit 0 (STC) of parameter No. 10485 = 1), but the setting is such that the workpiece coordinate system is used as the programming coordinate system (bit 5 (WKP) of parameter No. 19696 = 1).</li> </ul>
0517	SETTING ERROR AMOUNT IS OUT OF RANGE	<p>An attempt was made to start workpiece setting error compensation when a rotation direction setting error was outside the range set in the corresponding parameter No. 11753 to 11758.</p>
0520	ILLEGAL FORMAT IN G10.8L1	<p>An illegal command was specified to change a tolerance of smooth TCP.</p> <ul style="list-style-type: none"> <li>• A negative value was specified as a tolerance. <ul style="list-style-type: none"> <li>- Specify positive values as addresses "<math>\alpha</math>" and "<math>\beta</math>".</li> </ul> </li> <li>• An invalid P value was specified. <ul style="list-style-type: none"> <li>- Specify either 0 or 1 as address "P".</li> </ul> </li> <li>• Address P is specified together with addresses "<math>\alpha</math>" and "<math>\beta</math>". <ul style="list-style-type: none"> <li>- Specify only either address "P" or "addresses "<math>\alpha</math>" and "<math>\beta</math>".</li> </ul> </li> <li>• An invalid address was specified. <ul style="list-style-type: none"> <li>- In G10.8L1, only L, P, <math>\alpha</math>, <math>\beta</math>, O, N, and M can be specified.</li> </ul> </li> <li>• Another G code was specified at the same time. <ul style="list-style-type: none"> <li>- Specify G10.8L1 alone.</li> </ul> </li> <li>• G10.8 was specified in smooth TCP mode, but address "L" is not specified or the value of address "L" is not 1. <ul style="list-style-type: none"> <li>- In smooth TCP mode, only G10.8L1 can be specified.</li> </ul> </li> </ul>

Number	Message	Description
0521	ILLEGAL USAGE OF G10.8L1	Modal information used when specifying G10.8L1 contains an error. <ul style="list-style-type: none"> <li>The system is not in smooth TCP mode. <ul style="list-style-type: none"> <li>G10.8L1 can be specified in smooth TCP mode only.</li> </ul> </li> <li>The system is in smooth TCP mode, but the command is not linear interpolation (G01). <ul style="list-style-type: none"> <li>G10.8L1 can be specified only during linear interpolation (G01).</li> </ul> </li> </ul>
1001	AXIS CONTROL MODE ILLEGAL	Axis control mode is illegal.
1013	ILLEGAL POS. OF PROGRAM NO.	Address O or N is specified in an illegal location (e.g. after a macro statement).
1014	ILLEGAL FORMAT OF PROGRAM NO.	Address O or N is not followed by a number.
1016	EOB NOT FOUND	EOB (End of Block) code is missing at the end of a program input in the MDI mode.
1059	COMMAND IN BUFFERING MODE	The manual intervention compensation request signal MIGET became "1" when a advanced block was found during automatic operation. To input the manual intervention compensation during automatic operation, a sequence for manipulating the manual intervention compensation request signal MIGET is required in an M code instruction without buffering.
1077	PROGRAM IN USE	An attempt was made in the foreground to execute a program being edited in the background. The currently edited program cannot be executed, so end editing and restart program execution.
1079	PROGRAM FILE NOT FOUND	The program of the specified file No. is not registered in an external device. (external device subprogram call)
1080	DUPLICATE DEVICE SUB PROGRAM CALL	Another external device subprogram call was made from a subprogram after the subprogram called by the external device subprogram call.
1081	EXT DEVICE SUB PROGRAM CALL MODE ERROR	The external device subprogram call is not possible in this mode.
1090	PROGRAM FORMAT ERROR	A lowercase alphabetic character is found in other than an NC program statement comment section, program name, or folder name.
1091	DUPLICATE SUB-CALL WORD	More than one subprogram call instruction was specified in the same block.
1092	DUPLICATE MACRO-CALL WORD	More than one macro call instruction was specified in the same block.
1093	DUPLICATE NC-WORD & M99	An address other than O, N, P or L was specified in the same block as M99 during the macro modal call state.
1095	TOO MANY TYPE-2 ARGUMENT	More than ten sets of I, J and K arguments were specified in the type-II arguments (A, B, C, I, J, K, I, J, K, ...) for custom macros.
1096	ILLEGAL VARIABLE NAME	An illegal variable name was specified. A code that cannot be specified as a variable name was specified. [#_OFSxx] does not match the tool offset memory option configuration.
1097	TOO LONG VARIABLE NAME	The specified variable name is too long.
1098	NO VARIABLE NAME	The specified variable name cannot be used as it is not registered.
1099	ILLLEGAL SUFFIX [ ]	A suffix was not specified to a variable name that required a suffix enclosed by [ ]. A suffix was specified to a variable name that did not require a suffix enclosed by [ ]. The value enclosed by the specified [ ] was out of range.

Number	Message	Description
1100	CANCEL WITHOUT MODAL CALL	Call mode cancel (G67) was specified even though macro continuous-state call mode (G66) was not in effect.
1101	ILLEGAL CNC STATEMENT IRT.	An interrupt was made in a state where a custom macro interrupt containing a move instruction could not be executed.
1115	READ PROTECTED VARIABLE	An attempt was made in a custom macro to use on the right side of an expression a variable that can only be used on the left side of an expression.
1120	ILLEGAL ARGUMENT FORMAT	The specified argument in the argument function (ATAN, POW) is in error.
1124	MISSING DO STATEMENT	The DO instruction corresponding to the END instruction was missing in a custom macro.
1125	ILLEGAL EXPRESSION FORMAT	The description of the expression in a custom macro statement contains an error. A parameter program format error. The screen displayed to enter periodic maintenance data or item selection menu (machine) data does not match the data type.
1128	SEQUENCE NUMBER OUT OF RANGE	The jump destination sequence No. in a custom macro statement GOTO instruction was out of range (valid range: 1 to 99999999).
1131	MISSING OPEN BRACKET	The number of left brackets (()) is less than the number of right brackets (()) in a custom macro statement.
1132	MISSING CLOSE BRACKET	The number of right brackets (()) is less than the number of left brackets (()) in a custom macro statement.
1133	MISSING '='	An equal sign (=) is missing in the arithmetic calculation instruction in a custom macro statement.
1134	MISSING ','	A delimiter (,) is missing in a custom macro statement.
1137	IF STATEMENT FORMAT ERROR	The format used in the IF statement in a custom macro is in error.
1138	WHILE STATEMENT FORMAT ERROR	The format used in the WHILE statement in a custom macro is in error.
1139	SETVN STATEMENT FORMAT ERROR	The format used in the SETVN statement in a custom macro is in error.
1141	ILLEGAL CHARACTER IN VAR. NAME	The SETVN statement in a custom macro contacts a character that cannot be used in a variable name.
1142	TOO LONG V-NAME (SETVN)	The variable name used in a SETVN statement in a custom macro exceeds 8 characters.
1143	BPRNT/DPRNT STATEMENT FORMAT ERROR	The format used in the BPRINT statement or DPRINT statement is in error.
1144	G10 FORMAT ERROR	The G10 L No. contains no relevant data input or corresponding option. Data setting address P or R is not specified. An address not relating to the data setting is specified. Which address to specify varies according to the L No. The sign, decimal point or range of the specified address are in error.
1145	G10.1 TIME OUT	The response to a G10.1 instruction was not received from the PMC within the specified time limit.
1146	G10.1 FORMAT ERROR	The G10.1 instruction format is in error.
1152	G31.9/G31.8 FORMAT ERROR	The format of the G31.9 or G31.8 block is erroneous in the following cases: - The axis was not specified in the G31.9 or G31.8 block. - Multiple axes were specified in the G31.9 or G31.8 block. - The P code was specified in the G31.9 or G31.8 block.

Number	Message	Description
1153	CANNOT USE G31.9	G31.9 cannot be specified in this modal state. This alarm is also generated when G31.9 is specified when a group 07 G code (e.g. tool radius compensation) is not canceled.
1160	COMMAND DATA OVERFLOW	An overflow occurred in the position data within the CNC. This alarm is also generated if the target position of a command exceeds the maximum stroke as a result of calculation such as coordinate conversion, offset, or introduction of a manual intervention amount.
1180	ALL PARALLEL AXES IN PARKING	All of the axis specified for automatic operation are parked.
1196	ILLEGAL DRILLING AXIS SELECTED	An illegal axis was specified for drilling in a canned cycle for drilling. If the zero point of the drilling axis is not specified or parallel axes are specified in a block containing a G code in a canned cycle, simultaneously specify the parallel axes for the drilling axis.
1200	PULSCODER INVALID ZERO RETURN	The grid position could not be calculated during grid reference position return using the grid system as the one-revolution signal was not received before leaving the deceleration dog. This alarm is also generated when the tool does not reach a feedrate that exceeds the servo error amount preset to parameter No. 1841 before the deceleration limit switch is left (deceleration signal *DEC returns to "1").
1202	NO F COMMAND AT G93	F codes in the inverse time specification mode (G93) are not handled as modal, and must be specified in individual blocks.
1223	ILLEGAL SPINDLE SELECT	1) An attempt was made to execute an instruction that uses the spindle although the spindle to be controlled has not been set correctly. 2) Interpolation type rigid tapping was specified in a path in which the Cs contour control function is not enabled.
1282	ILLEGAL COMMAND IN 3-D OFFSET	An illegal G code was specified in the 3-dimensional tool compensation mode.
1283	ILLEGAL IJK IN 3-D OFFSET	When bit 0 (ONI) of parameter No. 6029 is set to 1, I, J, and K commands are specified without the decimal point in 3-dimensional tool compensation mode.
1298	ILLEGAL INCH/METRIC CONVERSION	An error occurred during inch/metric switching.
1300	ILLEGAL ADDRESS	The axis No. address was specified even though the parameter is not an axis-type while loading parameters or pitch error compensation data from a tape or by entry of the G10 parameter. Axis No. cannot be specified in pitch error compensation data.
1301	MISSING ADDRESS	The axis No. was not specified even though the parameter is an axis-type while loading parameters or pitch error compensation data from a tape or by entry of the G10 parameter. Or, data No. address N, or setting data address P or R are not specified.
1302	ILLEGAL DATA NUMBER	A non-existent data No. was found while loading parameters or pitch error compensation data from a tape or by entry of the G10 parameter. An invalid address R value is specified in a pattern program for each machining purpose on the high-speed high-precision setting screen. This alarm is also generated when illegal word values are found.

Number	Message	Description
1303	ILLEGAL AXIS NUMBER	An axis No. address exceeding the maximum number of controlled axes was found while loading parameters from a tape or by entry of the G10 parameter.
1304	TOO MANY DIGIT	Data with too many digits was found while loading parameters or pitch error compensation data from a tape.
1305	DATA OUT OF RANGE	Out-of-range data was found while loading parameters or pitch error compensation data from a tape. The values of the data setting addresses corresponding to L Nos. during data input by G10 was out of range. This alarm is also generated when NC programming words contain out-of-range values.
1306	MISSING AXIS NUMBER	A parameter which requires an axis to be specified was found without an axis No. (address A) while loading parameters from a tape.
1307	ILLEGAL USE OF MINUS SIGN	Data with an illegal sign was found while loading parameters or pitch error compensation data from a tape, or by entry of the G10 parameter. A sign was specified to an address that does not support the use of signs.
1308	MISSING DATA	An address not followed by a numeric value was found while loading parameters or pitch error compensation data from a tape.
1329	ILLEGAL MACHINE GROUP NUMBER	An machine group No. address exceeding the maximum number of controlled machine groups was found while loading parameters from a tape or by entry of the G10 parameter.
1330	ILLEGAL SPINDLE NUMBER	An spindle No. address exceeding the maximum number of controlled spindles was found while loading parameters from a tape or by entry of the G10 parameter.
1331	ILLEGAL PATH NUMBER	An path No. address exceeding the maximum number of controlled path was found while loading parameters from a tape or by entry of the G10 parameter.
1332	DATA WRITE LOCK ERROR	Could not load data while loading parameters, pitch error compensation data and work coordinate data from tape.
1333	DATA WRITE ERROR	Could not write data while loading data from tape.
1360	PARAMETER OUT OF RANGE (TLAC)	Illegal parameter setting. (Set value is out of range.)
1361	PARAMETER SETTING ERROR 1 (TLAC)	Illegal parameter setting. (axis of rotation setting)
1362	PARAMETER SETTING ERROR 2 (TLAC)	Illegal parameter setting (tool axis setting)
1370	PARAMETER SETTING ERROR (DM3H-1)	Out-of-range data was set during setting of the three-dimensional handle feed parameter.
1371	PARAMETER SETTING ERROR (DM3H-2)	An illegal axis of rotation was set during setting of the three-dimensional handle feed parameter.
1372	PARAMETER SETTING ERROR (DM3H-3)	An illegal master axis was set during setting of the three-dimensional handle feed parameter.
1373	PARAMETER SETTING ERROR (DM3H-4)	An illegal parallel axis or twin table was set during setting of the three-dimensional handle feed parameter.
1470	G40.1 –G42.1 PARAMETER MISS	A parameter setting related to normal direction control is illegal. The axis number of a normal direction controlled axis is set in parameter No. 5480, but that axis number is in the range of the number of controlled axes. The axis set as a normal direction controlled axis is not set as a rotation axis (bit 0 (ROT <sub>x</sub> ) of parameter No. 1006) = 1 and No.1022=0).

Number	Message	Description
1471	ILLEGAL COMMAND IN G40.1 -G42.1	A G code which cannot be specified in the normal direction control mode was specified.
1508	DUPLICATE M-CODE (INDEX TABLE REVERSING)	A function to which the same code as this M code is set exists. (index table indexing)
1509	DUPLICATE M-CODE (SPOS AXIS ORIENTATION)	A function to which the same code as this M code is set exists. (spindle positioning, orientation)
1510	DUPLICATE M-CODE (SPOS AXIS POSITIONING)	A function to which the same code as this M code is set exists. (spindle positioning, positioning)
1511	DUPLICATE M-CODE (SPOS AXIS RELEASE)	A function to which the same code as this M code is set exists. (spindle positioning, mode cancel)
1531	ILLEGAL USE OF DECIMAL POINT (F-CODE)	When the feedrate instruction contains valid data below the decimal point, the alarm is set and the F code contains valid data below the decimal point.
1532	ILLEGAL USE OF DECIMAL POINT (E-CODE)	When the feedrate instruction contains valid data below the decimal point, the alarm is set and the E code contains valid data below the decimal point.
1533	ADDRESS F UNDERFLOW (G95)	The feedrate for the hole drilling axis calculated from the F and S codes is too slow in the feed per single rotation mode (G95).
1534	ADDRESS F OVERFLOW (G95)	The feedrate for the hole drilling axis calculated from the F and S codes is too fast in the feed per single rotation mode (G95).
1535	ADDRESS E UNDERFLOW (G95)	The feedrate for the hole drilling axis calculated from the E and S codes is too slow in the feed per single rotation mode (G95).
1536	ADDRESS E OVERFLOW (G95)	The feedrate for the hole drilling axis calculated from the E and S codes is too fast in the feed per single rotation mode (G95).
1537	ADDRESS F UNDERFLOW (OVERRIDE)	The speed obtained by applying override to the F instruction is too slow.
1538	ADDRESS F OVERFLOW (OVERRIDE)	The speed obtained by applying override to the F instruction is too fast.
1539	ADDRESS E UNDERFLOW (OVERRIDE)	The speed obtained by applying override to the E instruction is too slow.
1540	ADDRESS E OVERFLOW (OVERRIDE)	The speed obtained by applying override to the E instruction is too fast.
1541	S-CODE ZERO	"0" has been instructed as the S code.
1542	FEED ZERO (E-CODE)	"0" has been instructed as the feedrate (E code).
1543	ILLEGAL GEAR SETTING	The gear ratio between the spindle and position coder, or the set position coder number of pulses is illegal in the spindle positioning function.
1544	S-CODE OVER MAX	The S command exceeds the maximum spindle rotation number.
1548	ILLGAL AXIS MODE	The spindle positioning axis/Cs contour control axis was specified during switching of the controlled axis mode.
1561	ILLEGAL INDEXING ANGLE	The specified angle of rotation is not an integer multiple of the minimum indexing angle.
1564	INDEX TABLE AXIS – OTHER AXIS SAME TIME	The index table indexing axis and another axis have been specified in the same block.
1567	INDEX TABLE AXIS DUPLICATE AXIS COMMAND	Index table indexing was specified during axis movement or on an axis for which the index table indexing sequence was not completed.

Number	Message	Description
1580	ENCODE ALARM (PSWD&KEY)	When an attempt was made to read a program, the specified password did not match the password on the tape and the password on tape was not equal to 0. When an attempt was made to punch an encrypted tape, the password was not in the range 0 to 99999999. The password parameter is No. 2210.
1581	ENCODE ALARM (PARAMETER)	When an attempt was made to punch an encrypted tape, the punch code parameter was set to EIA. Set bit 1 (ISO) of parameter No. 0000 to "0". An incorrect instruction was specified for program encryption or protection. This alarm is generated if an attempt is made to perform program editing, deletion, or range-specified punch-out in the protected range in the lock state. Or, a program outside the protected range is specified in range specification punch-out in the unlock state. The protected range is defined from the program No. preset by parameter No. 3222 up to the program No. preset to parameter No. 3223. When both parameters are set to "0", the protected range becomes O9000 to O9999.
1590	TH ERROR	A TH error was detected during reading from an input device. The read code that caused the TH error and how many statements it is from the block can be verified in the diagnostics screen.
1591	TV ERROR	An error was detected during the single-block TV error. The TV check can be suppressed by setting bit 0 (TVC) of parameter No. 0000 to "0".
1592	END OF RECORD	The EOR (End of Record) code is specified in the middle of a block. This alarm is also generated when the percentage at the end of the NC program is read. For the program restart function, this alarm is generated if a specified block is not found.
1593	EGB PARAMETER SETTING ERROR	Error in setting a parameter related to the EGB (1) The setting of SYN, bit 0 of parameter No. 2011, is not correct. (2) The slave axis specified with G81 is not set as a rotation axis. (ROT, bit 0 of parameter No. 1006) (3) Number of pulses per rotation (Parameter (No. 7772 or No. 7773) or (No. 7782 or 7783) is not set.) (4) For a hobbing-machine-compatible command, parameter No. 7710 is not specified. (5) The slave axis commanded by the G81 is the slave axis of simple spindle EGB. (6) No signal-based EGB synchronization ratio (parameters Nos. 7784 and 7785) has been set.
1594	EGB FORMAT ERROR	Error in the format of the block of an EGB command (1) T (number of teeth) is not specified in the G81 block. (2) In the G81 block, the data specified for one of T, L, P, and Q is out of its valid range. (3) In the G81 block, only one of P and Q is specified. (4) In the G81.5 block, there is no command for the master or slave axis. (5) In the G81.5 block, data out of the specified range is specified for the master or slave axis.



Number	Message	Description
1595	ILL-COMMAND IN EGB MODE	During synchronization with the EGB, a command that must not be issued is issued. (1) Slave axis command using G27, G28, G29, G30,G30.1, G33, G53, etc. (2) Inch/metric conversion command using G20, G21, etc. (3) Synchronization start command using G81 or G81.5 when bit 3 (ECN) of parameter No. 7731 is 0 (4) For the slave axis of the spindle EGB, the Cs contour control mode is not selected.
1596	EGB OVERFLOW	An overflow occurred in the calculation of the synchronization coefficient.
1597	EGB AUTO PHASE FORMAT ERROR	Format error in the G80 or G81 block in EGB automatic phase synchronization (1) R is outside the permissible range. (2) In spindle EGB, before the G81R2 command, the reference point return is not executed on the master spindle.
1598	EGB AUTO PHASE PARAMETER SETTING ERROR	Error in the setting of a parameter related to EGB automatic phase synchronization (1) The acceleration/deceleration parameter is not correct. (2) The automatic phase synchronization parameter is not correct.
1618	ILLEGAL P-DATA(WHEEL WEAR COMPENSATION)	There is an error in P-data in compensation selection of grinding wheel wear compensation. Alternatively, the P command is not present.
1619	ILLEGAL AXIS(WHEEL WEAR COMPENSATION)	The compensation axis was switched in the grinding wheel wear compensation mode or compensation vector hold mode. Alternatively, parameters Nos. 5071 and 5072, which determine the axis to be subjected to grinding wheel wear compensation, are incorrectly set.
1805	ILLEGAL COMMAND	[I/O Device] An attempt was made to specify an illegal command during I/O processing on an I/O device. [G30 Zero Return] The P address Nos. for instructing No. 2 to No. 4 zero return are each out of the range 2 to 4. [Single Rotation Dwell] The specified spindle rotation is "0" when single rotation dwell is specified. [3-dimensional tool compensation] A G code that cannot be specified was specified in the 3-dimensional tool compensation mode. Scaling instruction G51, skip cutting G31 and automatic tool length measurement G37 were specified.
1806	DEVICE TYPE MISS MATCH	An operation not possible on the I/O device that is currently selected in the setting was specified. This alarm is also generated when file rewind is instructed even though the I/O device is not a FANUC Cassette.
1807	PARAMETER SETTING ERROR	An I/O interface option that has not yet been added on was specified. The external I/O device and baud rate, stop bit and protocol selection settings are erroneous.
1808	DEVICE DOUBLE OPENED	An attempt was made to open a device that is being accessed.

Number	Message	Description
1809	ILLEGAL COMMAND IN G41/G42	Specified direction tool length compensation parameters are incorrect. A move instruction for a axis of rotation was specified in the specified direction tool length compensation mode.
1820	ILLEGAL DI SIGNAL STATE	<ol style="list-style-type: none"> <li>1. An each axis workpiece coordinate system preset signal was turned "1" in the state in which all axes on the path including the axis on which to perform preset with the each axis workpiece coordinate system were not stopped or in which a command was in execution.</li> <li>2. When an M code for performing preset with an each axis workpiece coordinate system preset signal was specified, the each axis workpiece coordinate system preset signal was not turned "1".</li> <li>3. The auxiliary function lock is enabled.</li> <li>4. When bit 6 (PGS) of parameter No. 3001 was set to 0 (M, S, T, and B codes are not output in the high speed program check mode), an M code for turning "1" an each axis workpiece coordinate system preset signal in the high speed program check mode was specified.</li> </ol>
1823	FRAMING ERROR(1)	The stop bit of the character received from the I/O device connected to reader/punch interface 1 was not detected.
1830	DR OFF(2)	The data set ready input signal DR of the I/O device connected to reader/punch interface 2 turned OFF.
1832	OVERRUN ERROR(2)	The next character was received from the I/O device connected to reader/punch interface 2 before it could read a previously received character.
1833	FRAMING ERROR(2)	The stop bit of the character received from the I/O device connected to reader/punch interface 2 was not detected.
1834	BUFFER OVERFLOW(2)	The NC received more than 10 characters of data from the I/O device connected to reader/punch interface 2 even though the NC sent a stop code (DC3) during data reception.
1889	ILLEGAL COMMAND IN G54.3	An illegal command was issued in G54.3 block. (1) An attempt was made to command G54.3 in a mode in which it cannot be accepted. (2) The command was not issued in a single block.
1892	ILLEGAL PARAMETER IN G43.3	A parameter related to nutating rotary head tool length compensation is incorrect.
1893	ILLEGAL PARAMETER IN G44.9	A parameter related to spindle unit compensation is incorrect.
1898	ILLEGAL PARAMETER IN G54.2	An illegal parameter (Nos. 6068 to 6076) was specified for fixture offset.
1912	V-DEVICE DRIVER ERROR (OPEN)	An error occurred during device driver control.
1919	FATAL ERROR(USB MEMORY)	A fatal error occurred in the USB file system. To restore the file system, turn the power off.
1924	UNEXPECTED ERROR(USB MEMORY)	An unexpected error occurred in the USB file system.
1925	ILLEGAL PATH/FILE(USB MEMORY)	An invalid path or file name was specified.
1926	ACCESS DENIED(USB MEMORY)	The USB memory could not be accessed.
1927	DEVICE IN FORMATTING(USB MEMORY)	The USB memory is being formatted.
1928	DEVICE NOT FOUND(USB MEMORY)	No USB memory is inserted. Check the connection.

Number	Message	Description
1930	ILLEGAL COMMAND AFTER RESTART	The restart block does not satisfy either of the following conditions: (1) An absolute command is specified in the block. (2) The G00 or G01 command is specified in the block. Select a block satisfying conditions (1) and (2) as the restart block.
1931	ILLEGAL MODE AFTER RESTART	Suppress motion is specified in a mode in which suppress motion is not available. Select a block in a mode in which suppress motion is available as the restart block.
1932	DEVICE IS FULL(USB MEMORY)	The capacity of the USB memory is insufficient.
1937	RECOGNITION ERROR(USB MEMORY)	The format of the USB memory is invalid. Format the USB memory in FAT or FAT32 format. If the alarm is still issued, replace the USB memory.
1938	END OF FILE FOUND(USB MEMORY)	The end of file was detected before EOR(%) was read. The file may be damaged.
1939	UNDEFINED ERROR(USB MEMORY)	An undefined error occurred.
1951	DEVICE IS BUSY(USB MEMORY)	The USB memory is busy.
1952	TOO MANY FILES(USB MEMORY)	The maximum number of files that can be opened concurrently is exceeded.
1953	REMOVED IN ACCESSING(USB MEMORY)	The USB memory was removed while being accessed.
1954	PATH/FILE EXIST(USB MEMORY)	The specified path or file already exists.
1955	PATH/FILE NOT FOUND(USB MEMORY)	The specified path or file is not found.
1956	DEVICE OVERCURRENT(USB MEMORY)	Overcurrent was detected in the USB memory. Replace the USB memory.
1957	PARITY ERROR(USB MEMORY)	A parity error occurred in the USB memory. Turn the power to the CNC off.
1960	ACCESS ERROR (MEMORY CARD)	Illegal memory card accessing This alarm is also generated during reading when reading is executed up to the end of the file without detection of the EOR code.
1961	NOT READY (MEMORY CARD)	The memory card is not ready.
1962	CARD FULL (MEMORY CARD)	The memory card has run out of space.
1963	CARD PROTECTED (MEMORY CARD)	The memory card is write-protected.
1964	NOT MOUNTED (MEMORY CARD)	The memory card could not be mounted.
1965	DIRECTORY FULL (MEMORY CARD)	The file could not be generated in the root directory for the memory card.
1966	FILE NOT FOUND (MEMORY CARD)	The specified file could not be found on the memory card.
1967	FILE PROTECTED (MEMORY CARD)	The memory card is write-protected.
1968	ILLEGAL FILE NAME (MEMORY CARD)	Illegal memory card file name
1969	ILLEGAL FORMAT (MEMORY CARD)	Check the file name.
1970	ILLEGAL CARD (MEMORY CARD)	This memory card cannot be handled.
1971	ERASE ERROR (MEMORY CARD)	An error occurred during memory card erase.
1972	BATTERY LOW (MEMORY CARD)	The memory card battery is low.
1973	FILE ALREADY EXIST	A file having the same name already exists on the memory card.
1990	SPL:ILLEGAL AXIS COMMAND	The axis specified by the smooth interpolation (G5.1Q2) is illegal.

Number	Message	Description
1993	SPL:CAN'T MAKE VECTOR	The end point and the 2 previous point are the same in generation of the 3-dimensional tool compensation vector by the end point for smooth interpolation.
1995	ILLEGAL PARAMETER IN G41.2/G42.2	The parameter settings (parameters Nos. 6080 to 6089) for determining the relationship between the axis of rotation and the rotation plane are incorrect.
1999	ILLEGAL PARAMETER IN G41.3	The parameter settings (parameters Nos. 6080 to 6089) for determining the relationship between the axis of rotation and the rotation plane are incorrect.
2002	NO KNOT COMMAND (NURBS)	Knot has not been specified, or a block not related to NURBS interpolation was specified in the NURBS interpolation mode.
2003	ILLEGAL AXIS COMMAND (NURBS)	An axis not specified as a control point was specified in the No. 1 block.
2004	ILLEGAL KNOT	There is an insufficient number of knot individual blocks.
2005	ILLEGAL CANCEL (NURBS)	The NURBS interpolation mode was turned OFF even though NURBS interpolation was not completed.
2006	ILLEGAL MODE (NURBS)	A mode that cannot be paired with the NURBS interpolation mode was specified.
2007	ILLEGAL MULTI-KNOT	Nested knots for each level can be specified for the start and end points.
2032	EMBEDDED ETHERNET/DATA SERVER ERROR	An error was returned in the built-in Ethernet/data server function. For details, see the error message screen of the built-in Ethernet or data server.
2051	#200-#499ILLEGAL P-CODE MACRO COMMON INPUT(NO OPTION)	An attempt was made to enter a custom macro common variable not existing in the system.
2052	#500-#549P-CODE MACRO COMMON SELECT(CANNOT USE SETVN)	The variable name cannot be entered. The SETVN command cannot be used with the P-CODE macro common variables #500 to #549.
2053	THE NUMBER OF #30000 IS UNMATCH	An attempt was made to enter a P-CODE-only variable not existing in the system.
2054	THE NUMBER OF #40000 IS UNMATCH	An attempt was made to enter an extended P-CODE-only variable not existing in the system.
2060	ILLEGAL PARAMETER IN G43.4/G43.5	The parameter for the pivot tool length compensation is incorrect.
2061	ILLEGAL COMMAND IN G43.4/G43.5	An illegal command was specified in tool center point control. <ul style="list-style-type: none"> <li>- A rotation axis command was specified in tool center point control (type 2) mode.</li> <li>- With a table rotary type or mixed-type machine, a I, J, or K command was specified in the tool center point control (type 2) command (G43.5) block.</li> <li>- A command that does not move the tool center point (only a rotation axis is moved) was specified for the workpiece in the G02 mode.</li> <li>- G43.4 or G43.5 was specified in the tool center point control mode.</li> <li>- When the workpiece coordinate system is set as the programming coordinate system (bit 5 (WKP) of parameter No. 19696 is 1), G02 or G03 was specified while the rotation axis was not perpendicular to the plane.</li> </ul>
2070	G02.1/ G03.1 FORMAT ERROR	<ul style="list-style-type: none"> <li>- The format is invalid.</li> <li>- The specified arc exceeds the interpolation enable range.</li> </ul>
4010	ILLEGAL REAL VALUE OF OBUF :	The real value for a output buffer is in error.

Number	Message	Description
5006	TOO MANY WORD IN ONE BLOCK	The number of words in a block exceeds the maximum. The maximum is 26 words. However, this figure varies according to NC options. Divide the instruction word into two blocks.
5007	TOO LARGE DISTANCE	Due to compensation, point of intersection calculation, interpolation or similar reasons, a movement distance that exceeds the maximum permissible distance was specified. Check the programmed coordinates or compensation amounts.
5009	PARAMETER ZERO (DRY RUN)	The dry run rate parameter No. 1410 or the parameter for the maximum cutting feedrate for each axis is 0. The parameter for the maximum cutting feedrate for each axis is No. 1432 if acceleration/deceleration before interpolation is enabled and No. 1430 otherwise. Functions that cause acceleration/deceleration before interpolation include AI contour control, tool center point control, and workpiece setting error compensation.
5010	END OF RECORD	The EOR (End of Record) code is specified in the middle of a block. This alarm is also generated when the percentage at the end of the NC program is read.
5011	PARAMETER ZERO (CUT MAX)	The setting of the parameter for the maximum cutting feedrate is 0. The parameter is No. 1432 if acceleration/deceleration before interpolation is enabled and No. 1430 otherwise. Functions that cause acceleration/deceleration before interpolation include AI contour control, tool center point control, and workpiece setting error compensation.
5014	TRACE DATA NOT FOUND	A transfer could not be made because of no trace data.
5015	NO ROTATION AXIS	No rotation axis was found in a handle feed in the tool axis direction or in the tool axis right angle direction.
5016	ILLEGAL COMBINATION OF M CODES	M codes which belonged to the same group were specified in a block. Alternatively, an M code which must be specified without other M codes in the block was specified in a block with other M codes.
5018	POLYGON SPINDLE SPEED ERROR	In G51.2 mode, the speed of the spindle or polygon synchronous axis either exceeds the clamp value or is too small. The specified rotation speed ratio thus cannot be maintained. For polygon turning between spindles: More information as to why this alarm occurred is indicated in diagnosis data No. 0471.
5020	PARAMETER OF RESTART ERROR	An invalid value is set in parameter No. 7310, which specifies the axis order in which the tool is moved along axes to the machining restart position in dry run. A value ranging from 1 to the number of controlled axes may be set in this parameter.
5043	TOO MANY G68 NESTING	Three-dimensional coordinate conversion has been specified three or more times. To perform another coordinate conversion, perform cancellation, then specify the coordinate conversion.

Number	Message	Description
5044	G68 FORMAT ERROR	Errors for three-dimensional coordinate conversion command are: (1) No I, J, or K command was issued in three-dimensional coordinate conversion command block. (without coordinate rotation option) (2) All of I, J, or K command were 0 in three-dimensional coordinate conversion command block. (3) No rotation angle R was not commanded in three-dimensional coordinate conversion command block.
5046	ILLEGAL PARAMETER (S-COMP)	The setting of a parameter related to straightness compensation contains an error. Possible causes include: <ul style="list-style-type: none"> <li>- A non-existent axis number is set in a moving or compensation axis parameter.</li> <li>- More than 128 pitch error compensation points are set between the furthest points in the negative and position regions.</li> <li>- The straightness compensation point numbers do not have correct magnitude relationships.</li> <li>- No straightness compensation point is found between the furthest pitch error compensation point in the negative region and that in the positive region.</li> <li>- The compensation per compensation point is either too large or too small.</li> </ul>
5050	ILL-COMMAND IN G81.1 MODE	During chopping, a move command has been issued for the chopping axis.
5058	G35/G36 FORMAT ERROR	A command for switching the major axis has been specified for circular threading. Alternatively, a command for setting the length of the major axis to 0 has been specified for circular threading.
5060	ILLEGAL PARAMETER IN G02.3/G03.3	The axis parameter setting to perform an exponential interpolation is in error. Parameter No. 5641: A liner axis number for performing an exponential interpolation Parameter No. 5642: A rotation axis number for performing an exponential interpolation The settable value is 1 to the number of control axes, but it must not be duplicated.
5061	ILLEGAL FORMAT IN G02.3/G03.3	The exponential interpolation command (G02.3/G03.3) has a format error. The command range for address I or J is -89.0 to -1.0 or +1.0 to +89.0. No I or J is specified or out-of-range value is specified. No address R, or 0 is specified.
5062	ILLEGAL COMMAND IN G02.3/G03.3	The value specified in an exponential interpolation command (G02.3/03.3) is illegal. A value that does not allow exponential interpolation is specified. (For example, the value for I <sub>n</sub> is 0 or negative.)
5064	DIFFERRENT AXIS UNIT	Circular interpolation has been specified on a plane consisting of axes having different increment systems.
5065	DIFFERRENT AXIS UNIT(PMC AXIS)	Axes having different increment systems have been specified in the same DI/DO group for PMC axis control. Modify the setting of parameter No. 8010.

Number	Message	Description
5066	RESTART ILLEGAL SEQUENCE NUMBER	A sequence number from 7000 to 7999 was read during the search for the next number in a restart program for the back or restart function.
5068	FORMAT ERROR IN G31P90	No travel axis was specified. Two or more travel axes were specified.
5073	NO DECIMAL POINT	No decimal point has been specified for an address requiring a decimal point.
5074	ADDRESS DUPLICATION ERROR	The same address has been specified two or more times in a single block. Alternatively, two or more G codes in the same group have been specified in a single block.
5085	SMOOTH IPL ERROR 1	A block for specifying smooth interpolation contains a syntax error.
5110	IMPROPER G-CODE (AICC MODE)	An unspecifiable G code was specified in the AI contour control mode.
5115	ILLEGAL ORDER (NURBS)	There is an error in the specification of the rank.
5116	ILLEGAL KNOT VALUE (NURBS)	Monotone increasing of knots is not observed.
5117	ILLEGAL 1ST CONTROL POINT (NURBS)	The first control point is incorrect. Or, it does not provide a continuity from the previous block.
5118	ILLEGAL RESTART (NURBS)	After manual intervention with manual absolute mode set to on, NURBS interpolation was restarted.
5122	ILLEGAL COMMAND IN SPIRAL	A spiral interpolation or conical interpolation command has an error. Specifically, this error is caused by one of the following: 1) L = 0 is specified. 2) Q = 0 is specified. 3) R/, R/, C is specified. 4) Zero is specified as height increment. 5) Zero is specified as height difference. 6) Three or more axes are specified as the height axes. 7) A height increment is specified when there are two height axes. 8) Q is specified when radius difference = 0. 9) Q < 0 is specified when radius difference > 0. 10) Q > 0 is specified when radius difference < 0. 11) A height increment is specified when no height axis is specified.
5123	OVER TOLERANCE OF END POINT IN SPIRAL	The difference between a specified end point and the calculated end point exceeds the allowable range (parameter 3471).
5124	CAN NOT COMMAND SPIRAL	A spiral interpolation or conical interpolation was specified in any of the following modes: 1) Scaling 2) Polar coordinate interpolation 3) In tool radius-tool nose radius compensation mode, the center is set as the end point.
5130	NC AND SUPERIMPOSE AXIS CONFLICT	In the PMC superposition axis control, the NC command and The PMC axis control command were conflicted. Modify the program and the ladder.
5131	NC COMMAND IS NOT COMPATIBLE	The PMC axis control and three-dimensional coordinate conversion or a polar coordinate interpolation were specified simultaneously.
5132	CANNOT CHANGE SUPERIMPOSED AXIS	The superposition axis was selected for the axis for which the PMC superposition axis is being controlled.
5155	NOT RESTART PROGRAM BY G05	When learning control/preview repetitive control was enabled, an attempt was made to use feed hold or interlock to stop high-speed cycle machining/high-speed binary operation. Neither feed hold nor interlock can be used in such a case.

Number	Message	Description
5195	DIRECTION CAN NOT BE JUDGED	Measurement is invalid in the tool compensation measurement value direct input B function. [For 1-contact input] 1. The recorded pulse direction is not constant. - The machine is at a stop in the offset write mode. - The servo power is off. - Pulse directions are diverse. 2. The tool is moving along the two axes (X-axis and Y-axis). [For the movement direction discrimination specification] 1. The recorded pulse direction is not constant. - The machine is at a stop in the offset write mode. - The servo power is off. - Pulse directions are diverse. 2. The tool is moving along the two axes (X-axis and Z-axis). 3. The direction indicated by the tool compensation write signal does not match the movement direction of the axis.
5196	ILLEGAL AXIS OPERATION	During HPCC or during the execution of a 5-axis-related function, an unavailable function was used.
5199	ILLEGAL FINE TORQUE SENSING PARAMETER	A parameter for fine torque sensing is incorrectly set. - The control axis number of the target axis is invalid.
5211	ILLEGAL AXIS OPERATION	In servo spindle synchronization mode, a servo axis command was executed from the CNC. Correct the program.
5219	CAN NOT RETURN	Manual intervention and return cannot be performed during execution of three-dimensional coordinate system conversion, tilted working plane command, tool center point control, or work setting error compensation.
5220	REFERENCE POINT ADJUSTMENT MODE	In case of distance coded linear scale I/F, the reference point auto setting bit 2 of parameter No.1819 is set to "1". Move the machine to reference position by manual operation and execute manual reference return.
5242	ILLEGAL AXIS NUMBER	A master axis number or a slave axis number was not set correctly when the flexible synchronization control mode was turned from off to on during automatic operation. In inter-path flexible synchronous control, this alarm is issued in either of the following cases. (The alarm is issued at the start of inter-path flexible synchronous control.) 1. The axis number of the master or slave axis is incorrect. 2. The master and slave axis settings make a loop.
5243	DATA OUNTRANGE	A gear ratio was not set correctly when the flexible synchronization control mode was turned from off to on during automatic operation.
5244	TOO MANY DI ON	<ul style="list-style-type: none"> <li>• When an attempt was made to change the flexible synchronous control status, the select signal was not turned on or off after the execution of the M code.</li> <li>• An attempt was made to turn flexible synchronous control on or off without stopping the tool along all axes. (Except when automatic phase synchronization for flexible synchronous control is used)</li> <li>• Flexible synchronous control was turned off in any of the following function modes: <ul style="list-style-type: none"> <li>- Tool center point control</li> <li>- Tilted working plane command</li> <li>- 3-dimensional cutter compensation</li> <li>- Workpiece setting error compensation</li> </ul> </li> </ul>



Number	Message	Description
5245	OTHERAXIS ARE COMMANDED	<ul style="list-style-type: none"> <li>- For a flexible synchronization control group for which a PMC axis was a master axis, an attempt was made to turn on the synchronous mode during time other than automatic operation.</li> <li>- An attempt was made to turn on a synchronization group for which an PMC axis was a master axis when there existed a flexible synchronization control group for which a non-PMC, normal axis was a master axis.</li> <li>- The master and slave axes as synchronous axes overlap the EGB dummy axis.</li> <li>- The master and slave axes as synchronous axes overlap the chopping axis.</li> <li>- The master and slave axes as synchronous axes overlap the axis related to angular axis control.</li> <li>- The master and slave axes as synchronous axes overlap the axis related to composite control.</li> <li>- The master and slave axes as synchronous axes overlap the axis related to superposition control.</li> <li>- The slave axis as a synchronous axis overlaps the axis related to synchronization control.</li> <li>- The reference position return mode is turned on (was turned on).</li> <li>- Over travel alarm occurs on slave axis.</li> <li>- A servo alarm occurred in a path in inter-path flexible synchronous control.</li> <li>- An emergency stop was applied in another path in inter-path flexible synchronous control.</li> <li>- When an attempt was made to execute flexible synchronization between different paths during automatic operation, the inter-path flexible synchronous mode was not enabled.</li> </ul>
5255	G12.4/G13.4 FORMAT ERROR	The specified P, I, and K are incorrect or I is less than K.
5256	G12.4/G13.4 EXECUTION ERROR	<ol style="list-style-type: none"> <li>1) In continuous circle motion-based groove cutting mode, a command other than G01, G02, G03, G04, G90, G91, and auxiliary functions is specified.</li> <li>2) In a mode that cannot be used, the continuous circle motion-based groove cutting command is specified.</li> </ol>
5257	G41/G42 NOT ALLOWED IN MDI MODE	Tool radius/tool nose radius compensation was specified in MDI mode. (Depending on the setting of the bit 4 (MCR) of parameter No. 5008)
5303	TOUCH PANEL ERROR	The touch panel is not connected correctly, or the touch panel cannot be initialized when the power is turned on. Correct the cause then turn on the power again.

Number	Message	Description
5305	ILLEGAL SPINDLE NUMBER	In a spindle select function by address P for a multiple spindle control, <ol style="list-style-type: none"> <li>1) Address P is not specified.</li> <li>2) Parameter No.3781 is not specified to the spindle to be selected.</li> <li>3) An illegal G code which cannot be commanded with an S_P_; command is specified.</li> <li>4) A multi spindle cannot be used because the bit 1 (EMS) of parameter No. 3702 is 1.</li> <li>5) The spindle amplifier number of each spindle is not set in parameter No. 3717.</li> <li>6) A prohibited command for a spindle was issued (parameter No. 11090).</li> <li>7) An invalid value is set in parameter No. 11090.</li> </ol>
5312	ILLEGAL COMMAND IN G10 L75/76/77	One of formats in G10L75, G10L76, or G10L77 to G11 commands is in error, or the command value is out of data range. Modify the program.
5316	TOOL TYPE NUMBER NOT FOUND	A tool with the specified tool-type number could not be found. Modify the program or register the tool.
5317	ALL TOOL LIFE IS OVER	The lives of all tools with the specified tool-type number have expired. Replace the tool.
5320	DIA./RAD. MODE CAN'T BE SWITCHED .	In any of the following states, diameter/radius specification was switched: <ol style="list-style-type: none"> <li>1) When a buffered program is being executed</li> <li>2) When a movement is being made on the axis</li> </ol>
5324	REFERENCE RETURN INCOMPLETE	Manual reference position return cannot be performed during three-dimensional coordinate conversion, execution of the tilted working plane command, or workpiece setting error compensation.
5329	M98 AND NC COMMAND IN SAME BLOCK	A subprogram call which is not a single block was commanded during canned cycle mode.
5339	ILLEGAL FORMAT COMMAND IS EXECUTED IN SYNC/MIX/OVL CONTROL.	<ol style="list-style-type: none"> <li>1. The value of P, Q, or L specified by G51.4/G50.4/G51.5/G50.5/G51.6/G50.6 is invalid.</li> <li>2. A duplicate value is specified by parameter No. 12600.</li> </ol>
5346	RETURN TO REFERENCE POINT	The coordinate establishment of the Cs contour control axis is not made. Perform a manual reference position return. <ol style="list-style-type: none"> <li>1. When Cs coordinate establishment is made for the Cs-axis for which the Cs-axis reference position status signal CSPENx is 0</li> <li>2. When positional information is not sent from the spindle amplifier</li> <li>3. When the servo off state is entered during the start of Cs-axis coordinate establishment</li> <li>4. When the Cs-axis is subjected to synchronous control or superposition control</li> <li>5. When the emergency stop state is entered during coordinate establishment</li> <li>6. When an attempt is made to release composite control for the Cs axis being subjected to coordinate establishment</li> <li>7. When an attempt is made to start synchronous, composite, or superposition control for the Cs axis being subjected to coordinate establishment.</li> </ol>

Number	Message	Description
5360	TOOL INTERFERENCE CHECK ERROR	This alarm is issued when interference with another tool is caused by a data modification based on G10 data input or file reading or when an attempt is made to modify the tool figure data of a tool registered in the cartridge.
5361	ILLEGAL MAGAZINE DATA	Tools stored in the cartridge are interfering with each other. Reregister the tools in the cartridge, or modify the tool management data or tool figure data. If this alarm is issued, no tool interference check is made when tools are registered in the cartridge management table. Moreover, empty pot search operation does not operate normally. If this alarm is issued, the power must be turned off before operation is continued.
5362	CONVERT INCH/MM AT REF-POS	An inch/metric conversion was performed at a position other than the reference position. Perform an inch/metric conversion after returning to the reference position.
5364	ILLEGAL COMMAND IN PROGRAM CHECK	<ol style="list-style-type: none"> <li>(1) An unspecifiable G code was specified in the high speed program check mode.</li> <li>(2) The angular axis control option or customer's board option is enabled.</li> <li>(3) One of the following operations was performed. <ul style="list-style-type: none"> <li>- Chopping in the high speed program check mode</li> <li>- Starting the high speed program check mode during chopping</li> <li>- High speed cycle machining in the high speed program check mode</li> <li>- Reference position return of an axis for which the reference position is not established, in the high speed program check mode</li> </ul> </li> <li>(4) Switching of PMC axis selection signal EAX*&lt;G0136&gt; was performed.</li> <li>(5) G10 was specified for bit 3 (PGR) of parameter No. 3454 in the high speed program check mode.</li> <li>(6) G10 was specified for bit 6 (PGS) of parameter No. 3001 in the high speed program check mode.</li> </ol>
5365	NOT CHANGE OF PROGRAM CHECK MODE	(1) Switching of high speed program check input signal PGCK<Gn290.5> was performed during execution of the program.
5372	IMPROPER MODAL G-CODE (G53.2)	In a block in which G53.2 is specified, a G code in group 01 other than G00 and G01 is specified. Or, G53.2 is specified when the modal G code in group 01 is in a state other than the G00 and G01 states.
5373	ARGUMENT CONVERSION ERROR	For outputting a target MDI program for program restart, a macro call argument cannot be converted to a 9-digit number.
5374	FSC MODE MISMATCH IN RESTART	The current flexible synchronous mode differs from the flexible synchronous mode specified in a programmed command in the program restart block.
5375	FSC MODE CAN NOT CHANGED	The flexible synchronous mode was changed during the execution of program restart.
5376	FSC SLAVE AXIS CAN NOT COMMANDED	In the flexible synchronous mode, a command was specified for the slave axis.
5377	INVALID COMMAND AFTER FSC OFF	After the flexible synchronous mode was canceled, an incremental command was specified before an absolute command for the axis specified as the slave axis.
5378	INVALID RESTART BLOCK	The block specified as the restart block after the flexible synchronous mode was canceled was not a block after an absolute command for the axis specified as the slave axis.

Number	Message	Description
5379	WRITE PROTECTED TO SLAVE AXIS	It is not possible to directly set the parameters for the slave axis under axis synchronous control.
5381	INVALID COMMAND IN FSC MODE	An attempt was made to issue the following commands: 1 When the reference position for the master axis under flexible synchronization control has not been established, G28 command for the master axis. 2 G27/G28/G29/G30/G30.1/G53 command for a slave axis.
5384	RETRACT FOR RIGID CANNOT BE CMD.	In retraction for rigid tapping by the G30 command, coordinate mode used when rigid tapping is stopped and that used for retraction for rigid tapping are different.
5391	CAN NOT USE G92	Workpiece coordinate system setting G92 (or G50 for the lathe system G-code system A) cannot be specified. (1) After tool length compensation was changed by tool length compensation shift type, G92 was specified when no absolute command is present. (2) G92 was specified in the block in which G49 is present.
5406	G41.3/G40 FORMAT ERROR	(1) The G41.3 or G40 block contains a move command. (2) The G41.3 block contains a G or M code that suppresses buffering.
5407	ILLEGAL COMMAND IN G41.3	(1) In the G41.3 mode, a G code of group 01 other than G00 and G01 is specified. (2) In the G41.3 mode, an offset command (a G code of group 07) is specified. (3) The block next to G41.3 (startup) specifies no movement.
5408	G41.3 ILLEGAL START_UP	(1) In a mode of group 01 other than G00 and G01, G41.3 (startup) is specified. (2) The included angle between the tool vector and move vector is 0 or 180 degrees at the time of startup.
5420	ILLEGAL PARAMETER IN G43.4/G43.5	A parameter related to tool center point control is illegal. - Acceleration/deceleration before interpolation is disabled. Set parameter No. 1660. - Rapid traverse acceleration/deceleration before interpolation is disabled. Set bit 1 of parameter No. 1401, bit 5 of parameter No. 19501, parameter No. 1671, and parameter No. 1672. - The AI contour control I or AI contour control II option is absent. Set bit 2 (AAI) of parameter No. 11260 to 0.

Number	Message	Description
5421	ILLEGAL COMMAND IN G43.4/G43.5	<p>An illegal command was specified in tool center point control.</p> <ul style="list-style-type: none"> <li>- A rotation axis command was specified in tool center point control (type 2) mode.</li> <li>- With a table rotary type or mixed-type machine, a I,J,K command was specified in the tool center point control (type 2) command (G43.5) block.</li> <li>- A command that does not move the tool center point (only a rotation axis is moved) was specified for the workpiece in the G02/G03 mode.</li> <li>- When the workpiece coordinate system is set as the programming coordinate system (bit 5 (WKP) of parameter No. 19696 is 1), G02 or G03 was specified while the rotation axis was not perpendicular to the plane.</li> <li>- A G code not specifiable during the tool center point control mode was specified.</li> <li>- The modal code used to specify tool center point control is incorrect.</li> <li>- If, in tool center point control mode, any of the following conditions is met, an axis not related to tool center point control (non 5-axis machining control axis) is specified: <ul style="list-style-type: none"> <li>(1) The option, the expansion of axis move command in tool center point control, is not provided.</li> <li>(2) The number of non 5-axis machining control axes exceeds the maximum number of axes that can be specified.</li> <li>(3) Nano smoothing or NURBS interpolation is performed.</li> </ul> </li> <li>- When bit 0 (RCM) of parameter No. 11200 is set to 0 to disable tool direction compensation, tool center point control is specified during the workpiece setting error compensation/tilted working plane command mode.</li> <li>- When tool posture control is enabled under tool center point control (type 2), a command is specified to set a tool posture near a singular point. (This alarm may be suppressed with bit 3 (NPC) of parameter No. 19696.) Check the machine configuration and specification.</li> <li>- When tool posture control is enabled under tool center point control (type 1), a rotary axis angular displacement that disables tool posture control is specified. Check the machine configuration and specification.</li> <li>- During tool center point control (type 2) or tool posture control, nano smoothing or NURBS interpolation is specified. Check the specification.</li> <li>- For nano smoothing in tool center point control (type 1), only linear axes are specified as axes for nano smoothing. Specify rotation axes.</li> <li>- In a state in which the shift of a mirror image remains, tool center point control, tool posture control, or the cutting point command is specified.</li> </ul>
5422	EXCESS VELOCITY IN G43.4/G43.5	An attempt was made to make a movement at an axis feedrate exceeding the maximum cutting feedrate by tool center point control.
5424	ILLEGAL TOOL DIRECTION	The rotation axis position for specifying the tool axis direction is not $\pm 90^\circ \times n$ ( $n = 0, 1, 2, \dots$ ).
5425	ILLEGAL OFFSET VALUE	The offset number is incorrect.

Number	Message	Description
5430	ILLEGAL COMMAND IN 3-D CIR	In a modal state in which three-dimensional circular interpolation cannot be specified, a three-dimensional circular interpolation (G02.4/G03.4) is specified. Alternatively, in three-dimensional circular interpolation mode, a code that cannot be specified is specified.
5432	G02.4/G03.4 FORMAT ERROR	A three-dimensional circular interpolation command (G02.4/G03.4) is incorrect.
5433	MANUAL INTERVENTION IN G02.4/G03.4 (ABS ON)	In three-dimensional circular interpolation mode (G02.4/G03.4), manual intervention was made when the manual absolute switch was on.
5435	PARAMETER OUT OF RANGE (TLAC)	Illegal parameter setting. (Set value is out of range.) Check parameters Nos. 19655, 19656, 19657, and 1022.
5436	ILLEGAL PARAMETER SETTING OF ROTARY AXIS(TLAC)	Illegal parameter setting. (axis of rotation setting)
5437	ILLEGAL PARAMETER SETTING OF MASTER ROTARY AXIS(TLAC)	Illegal parameter setting. (master axis of rotation setting)
5445	CAN NOT COMMAND MOTION IN G39	Corner circular interpolation (G39) of tool radius/tool nose radius compensation is not specified alone but is specified with a move command.
5446	NO AVOIDANCE AT G41/G42	Because there is no interference avoidance vector, the interference check avoidance function of tool radius/tool nose radius compensation does not work.
5447	DANGEROUS AVOIDANCE AT G41/G42	The interference check avoidance function of tool radius/tool nose radius compensation operation will lead to danger.
5448	INTERFERENCE TO AVD. AT G41/G42	In the interference check avoidance function of tool radius/tool nose radius compensation, a further interference occurs for an already created interference avoidance vector.
5456	TOO MANY G68.2 NESTING	Tilted working plane command G68.2 was specified more than once. To perform another coordinate conversion, perform cancellation, then specify the coordinate conversion.
5457	G68.2 FORMAT ERROR	A G68.2 format error occurred.
5458	ILLEGAL USE OF G53.1/G53.6	<ul style="list-style-type: none"> <li>- G53.1 or G53.6 was specified preceding G68.2.</li> <li>- G53.1 or G53.6 needs to be specified solely.</li> <li>- There is no angle solution for the rotation axis that controls the tool axis direction in the +Z-axis direction of the feature coordinate system.</li> <li>- In the setting by which compensation in the tool direction is not performed (when bit 0 (RCM) of parameter No. 11200 is 0), G53.1 was specified in the workpiece placement error compensation mode.</li> <li>- No tool is specified with a G53.6 command.</li> </ul>

Number	Message	Description
5459	MACHINE PARAMETER INCORRECT	<ul style="list-style-type: none"> <li>- The parameter No. 19665 to No. 19667, No. 19680 to No. 19744 for configuring the machine are incorrect.</li> <li>- The axis specified with parameter No. 19681 or No. 19686 is not a rotary axis.</li> <li>- In parameter No. 1022, the basic three axes are not set.</li> <li>- A rotary axis end point found by the NC with tool center point control type 2, 3-dimensional cutter compensation type 2, or the tilted working plane command is not within the range set by parameter No. 19741 to No. 19744.</li> <li>- No rotary axis end point was found with tool center point control type 2 or 3-dimensional cutter compensation type 2. Check the machine configuration and specification.</li> <li>- On a machine whose rotary axis is a virtual axis, tool center point control type 2 or 3-dimensional cutter compensation type 2 was specified.</li> <li>- When programming is performed in the workpiece coordinate system, tool center point control type 2 or 3-dimensional cutter compensation type 2 is specified.</li> <li>- If a parameter for setting a 5-axis machining function, the reference rotation axis position, is to be set in the machine coordinate system (bit 7 (SPM) of parameter No. 19754 = 1), an inclined rotary axis is used.</li> </ul>

Number	Message	Description
5460	ILLEGAL USE OF 3-DIMENSIONAL CUTTER COMPENSATION	<ul style="list-style-type: none"> <li>- In the 3-dimensional cutter compensation mode (except the tool side offset function for a tool rotation type machine), a move command other than G00/G01 is specified.</li> <li>- With a table rotation type machine, when bit 1 (PTD) of parameter No. 19746 is set to 1, a plane selection is made with an axis other than the basic three axes at the start of 3-dimensional cutter compensation.</li> <li>- When bit 1 (SPG) of parameter No. 19607 is set to 1, there is a discrepancy between the machine type set in parameter No. 19680 and a G code specifying 3-dimensional cutter compensation (G41.2, G42.2, G41.4, G42.4, G41.5, or G42.5).</li> <li>- With a machine that is not of the tool rotation type, G41.3 is specified.</li> <li>- When bit 5 (WKP) of parameter No. 19696 is set to 0, and bit 4 (TBP) of parameter No. 19746 is set to 0, 3-dimensional cutter compensation and tool center point control are used at the same time.</li> <li>- A rotation axis command is specified in the 3-dimensional cutter compensation mode (type 2).</li> <li>- With a table rotation type or mixed type machine, IJK is specified in a block that specifies 3-dimensional cutter compensation (type 2) (G41.6/G42.6).</li> <li>- An illegal G code is specified in the 3-dimensional cutter compensation mode.</li> <li>- When 3-dimensional cutter compensation is specified, the modal state is illegal.</li> <li>- When the table coordinate system is set as the programming coordinate system, table rotate and 3-dimensional cutter compensation are specified after the start of tool center point control.</li> <li>- There is a difference in type1/type 2 specification between 3-dimensional cutter compensation and tool center point control.</li> <li>- When 3-dimensional cutter compensation and tool center point control are used at the same time, one of these functions that is specified earlier than the other is canceled earlier.</li> </ul>
5461	ILLEGAL USE OF G41.2/G42.2/G41.5/G42.5	A move command other than G00 or G01 was performed during 3-dimensional cutter compensation in a mixed-type machine.
5462	ILLEGAL COMMAND (G68.2/G69)	<ol style="list-style-type: none"> <li>(1) The modal setting used when G68.2 or G69 is specified is incorrect.</li> <li>(2) An unspecificable G code was specified in the G68.2 mode.</li> <li>(3) The offset vector of tool radius/tool nose radius compensation is not canceled when G68.2 or G69 is specified.</li> </ol>
5463	ILLEGAL PARAMETER IN 3-DIMENSIONAL CUTTER COMPENSATION	<p>A parameter related to 3-dimensional cutter compensation is illegal.</p> <ul style="list-style-type: none"> <li>- Acceleration/deceleration before interpolation is disabled. Set parameter No. 1660.</li> <li>- Rapid traverse acceleration/deceleration before interpolation is disabled. Set bit 1 (LRP) of parameter No. 1401, bit 5 (FRP) of parameter No. 19501, and parameters Nos. No.1671 and 1672.</li> </ul>



Number	Message	Description
5464	ILLEGAL COMMAND IN G43.8/G43.9	An illegal value is specified with the cutting point command of tool center point control. <ul style="list-style-type: none"> <li>- A value is specified that causes the angle formed by the tool length offset direction and the direction perpendicular to the cutting surface to exceed 90 degrees.</li> <li>- The tool radius offset is less than the corner-R offset.</li> <li>- On a tool rotation type machine, manual intervention is performed on the rotation axis.</li> </ul>
5557	NO MAX SP SPEED CLAMP COMMAND	No command for maximum spindle speed clamping (M series: G92S_; T series: G50S_) was not executed before the constant surface speed control command (G96S_) was started. Execute a command for maximum spindle speed clamping.

**(4) Parameter writing alarm (SW alarm)**

Number	Message	Description
SW0100	PARAMETER ENABLE SWITCH ON	The parameter setting is enabled (PWE, one bit of parameter No. 8000 is set to "1"). To set the parameter, turn this parameter ON. Otherwise, set to OFF.

**(5) Servo alarms (SV alarm)**

Number	Message	Description
SV0001	SYNC ALIGNMENT ERROR	In feed axis synchronization control, the amount of compensation for synchronization exceeded the parameter No. 8325 setting value. This alarm occurs for a master or slave axis.
SV0002	SYNC EXCESS ERROR ALARM 2	In feed axis synchronization control, the amount of synchronization error exceeded the parameter No. 8332 setting value. When the synchronization is not completed after power-up, the determination is made by the parameter value No. 8332 multiplied by the parameter No. 8330 multiplier. This alarm occurs only for a slave axis only.
SV0003	SYNCHRONOUS/COMPOSITE/SUPER IMPOSED CONTROL MODE CAN'T BE CONTINUED	Since as axis in synchronization, composition, or superposition mode caused a servo alarm, the mode could not be continued. If one of the axes in a mode causes a servo alarm, all axes relating to the axis enter the servo-off state. This alarm is generated to enable the cause of the servo-off state to be checked.
SV0004	EXCESS ERROR (G31)	The amount of positional deviation during torque limit skip command operation exceeded the limit value of the parameter No.6287.
SV0005	SYNC EXCESS ERROR (MCN)	In feed axis synchronization control, for synchronization, the difference value of the machine coordinate between a master and slave axes exceeded the parameter No. 8314 setting value. This alarm occurs for a master or slave axis.
SV0006	ILLEGAL TANDEM AXIS	For the slave axis under tandem control, absolute position detection is set (parameter bit 5 (APC) of parameter No. 1815 = 1).

Number	Message	Description
SV0007	SV ALM ANOTHER PATH(MULTI AMP.)	When a multi-axis amplifier was used in a multi-path system across paths, a servo alarm occurred on an axis belonging to another path. When a system with two or more paths and multiple servo axes between paths are controlled by a multi-axis amplifier, if a servo alarm occurs on an axis belonging to another path of the same amplifier, the MCC of the amplifier goes down and SV0401 V-READY OFF occurs on an axis belonging to the local path in the same amplifier. Since SV0401 is caused by a servo alarm occurred on an axis in another path, SV0007 is caused together to clearly indicate the fact. The axis belonging to another path in the same amplifier resolves the cause of the servo alarm.
SV0010	SV OVERHEAT	Amplifier internal overheat
SV0011	SV MOTOR OVER CURRENT(SOFT)	The digital servo software detected an abnormal specified value. Possible causes include an unconnected power cable, cable disconnection (open phase), and short-circuit.
SV0012	SV DRIVE OFF CIRCUIT FAILURE	The two drive off inputs are not in the same status or a drive off circuit error occurred.
SV0013	SV CPU BUS FAILURE	An error was found in CPU bus data in the amplifier.
SV0014	SV CPU WATCH DOG	An error occurred in CPU operation in the amplifier.
SV0015	SV LOW VOLT DRIVER	The driver power supply voltage has dropped in the amplifier. Possible causes include improper insertion of the control PC board and amplifier failure.
SV0016	SV CURRENT DETECT ERROR	An error was found in motor current detection data in the amplifier. Possible causes include improper insertion of the control PC board and amplifier failure.
SV0017	SV INTERNAL SERIAL BUS FAILURE	An error occurred in serial bus communication in the amplifier. Possible causes include improper insertion of the control PC board and amplifier failure.
SV0018	SV ROM DATA FAILURE	An error was found in ROM data in the amplifier.
SV0019	PS GROUND FAULT	A ground fault occurred in the motor, power cable, or amplifier.
SV0020	PS GROUND FAULT	A ground fault occurred in the motor, power cable, or amplifier.
SV0021	PS OVERCURRENT 2	Overcurrent flowed in the input circuit.
SV0022	PS OVERCURRENT 3	Overcurrent flowed in the input circuit.
SV0023	PS OVERCURRENT 4	Overcurrent flowed in the input circuit.
SV0024	PS SOFT THERMAL	A load higher than the rating was applied.
SV0025	PS OVER VOLT. DC LINK 2	Overvoltage of the DC link section
SV0026	PS OVER VOLT. DC LINK 3	Overvoltage of the DC link section
SV0027	PS OVER VOLT. DC LINK 4	Overvoltage of the DC link section
SV0028	PS LOW VOLT. DC LINK 2	The DC link voltage has dropped.
SV0029	PS LOW VOLT. DC LINK 3	The DC link voltage has dropped.
SV0030	PS LOW VOLT. DC LINK 4	The DC link voltage has dropped.
SV0031	PS ILLEGAL PARAMETER	An invalid value is set for a PS control parameter.
SV0032	PS CONTROL AXIS ERROR 1	An invalid value is set for parameter No. 2557.
SV0033	PS CONTROL AXIS ERROR 2	An invalid value is set for parameter No. 2557.
SV0034	PS HARDWARE ERROR	A PS hardware error was detected.
SV0301	APC ALARM: COMMUNICATION ERROR	Since the absolute-position detector caused a communication error, the correct machine position could not be obtained. (data transfer error) The absolute-position detector, cable, or servo interface module is thought to be defective.

Number	Message	Description
SV0302	APC ALARM: OVER TIME ERROR	Since the absolute-position detector caused an overtime error, the correct machine position could not be obtained. (data transfer error) The absolute-position detector, cable, or servo interface module is thought to be defective.
SV0303	APC ALARM: FRAMING ERROR	Since the absolute-position detector caused a framing error, the correct machine position could not be obtained. (data transfer error) The absolute-position detector, cable, or servo interface module is thought to be defective.
SV0304	APC ALARM: PARITY ERROR	Since the absolute-position detector caused a parity error, the correct machine position could not be obtained. (data transfer error) The absolute-position detector, cable, or servo interface module is thought to be defective.
SV0305	APC ALARM: PULSE ERROR	Since the absolute-position detector caused a pulse error, the correct machine position could not be obtained. The absolute-position detector, or cable is thought to be defective.
SV0306	APC ALARM: OVER FLOW ERROR	Since the amount of positional deviation overflowed, the correct machine position could not be obtained. Check to see the parameter No. 2084 or No. 2085.
SV0307	APC ALARM: MOVEMENT EXCESS ERROR	Since the machine moved excessively, the correct machine position could not be obtained.
SV0360	ABNORMAL CHECKSUM(INT)	The checksum alarm occurred on the built-in Pulsecoder.
SV0361	ABNORMAL PHASE DATA(INT)	The phase data abnormal alarm occurred on the built-in Pulsecoder.
SV0363	ABNORMAL CLOCK(INT)	The clock alarm occurred on the built-in Pulsecoder.
SV0364	SOFT PHASE ALARM(INT)	A digital servo soft detected an abnormality on the built in Pulsecoder.
SV0365	BROKEN LED(INT)	The digital servo software detected abnormal data on the built-in Pulsecoder.
SV0366	PULSE MISS(INT)	A pulse error occurred on the built-in Pulsecoder.
SV0367	COUNT MISS(INT)	A count error occurred on the built-in Pulsecoder.
SV0368	SERIAL DATA ERROR(INT)	The communications data could not be received from the built-in Pulsecoder.
SV0369	DATA TRANS. ERROR(INT)	A CRC error or stop bit error occurred in the communications data from the built-in Pulsecoder.
SV0380	BROKEN LED(EXT)	Separate detector error
SV0381	ABNORMAL PHASE (EXT)	An abnormal alarm in the position data occurred on the separate detector.
SV0382	COUNT MISS(EXT)	A count error occurred on the separate detector.
SV0383	PULSE MISS(EXT)	A pulse error occurred on the separate detector.
SV0384	SOFT PHASE ALARM(EXT)	The digital servo software detected abnormal data on the separate detector.
SV0385	SERIAL DATA ERROR(EXT)	The communications data could not be received from the separate detector.
SV0386	DATA TRANS. ERROR(EXT)	A CRC error or stop bit error occurred in the communications data from the standalone detector.
SV0387	ABNORMAL ENCODER(EXT)	An abnormality occurred on a separate detector. For more information, contact the scale manufacturer.
SV0401	IMPROPER V_READY OFF	Although the ready signal (PRDY) of the position control was ON, the ready signal (VRDY) of the velocity control was OFF.

Number	Message	Description
SV0403	CARD/SOFT MISMATCH	The combination of the axis control card and the servo software is incorrect. Probable causes are given below. - The correct axis control card is not attached. - The correct servo software is not installed in flash memory.
SV0404	IMPROPER V_READY ON	Although the ready signal (PRDY) of the position control was OFF, the ready signal (VRDY) of the velocity control was ON.
SV0407	EXCESS ERROR	The difference value of the amount of positional deviation for the synchronization axis exceeded the setting value. (during synchronization control only)
SV0409	DETECT ABNORMAL TORQUE	An abnormal load was detected on the servo motor, or during Cs axis or spindle positioning. The alarm can be canceled by RESET.
SV0410	EXCESS ERROR (STOP)	The amount of positional deviation during stopping exceeded the parameter No. 1829 setting value.
SV0411	EXCESS ERROR (MOVING)	The amount of positional deviation during traveling became excessive than the parameter setting value.
SV0413	LSI OVERFLOW	The counter for the amount of positional deviation overflowed
SV0415	MOTION VALUE OVERFLOW	The velocity exceeding the travel velocity limit was commanded.
SV0417	ILL DCTL SERVO PARAMETER	A digital servo parameter setting is incorrect.  When bit 4 of diagnosis data No. 203 is 1, an illegal parameter was detected by the servo software. Identify the cause with reference to diagnosis data No. 352.  When bit 4 of diagnosis data No. 203 is 0, the CNC software detected an illegal parameter. Probable causes are given below (see diagnosis data No. 280). 1) The value specified in parameter No. 2020 as the motor model falls outside the specified range. 2) The motor rotation direction in parameter No. 2022 is not set to a correct value (111 or -111). 3) The speed feedback pulse count per motor rotation in parameter No. 2023 is set to a negative or other incorrect value. 4) The position feedback pulse count per motor rotation in parameter No. 2024 is set to a negative or other incorrect value.
SV0420	SYNC TORQUE EXCESS	In feed axis synchronization control, for synchronization, the difference value of torque between a master and slave axes exceeded the parameter No. 2031 setting value. This alarm occurs for a master axis.
SV0421	EXCESS ERROR(SEMI-FULL)	The difference between the feedback from the semi and full sides exceeded the setting of parameter No.2118.
SV0422	EXCESS VELOCITY IN TORQUE	In torque control, the commanded permissible velocity was exceeded.
SV0423	EXCESS ERROR IN TORQUE	In torque control, the total permissible move value specified as a parameter was exceeded.
SV0430	SV MOTOR OVERHEAT	The servo motor has overheated.
SV0431	PS OVERLOAD	Overheat
SV0432	PS LOW VOLT. CONTROL	The control power supply voltage has dropped.
SV0433	PS LOW VOLT. DC LINK	Low DC link voltage

Number	Message	Description
SV0434	SV LOW VOLT CONTROL	Low control power voltage
SV0435	SV LOW VOLT DC LINK	Low DC link voltage
SV0436	SOFTTHERMAL(OVC)	The digital servo software detected a software thermal (OVC).
SV0437	PS OVERCURRENT	Overcurrent on input circuit section.
SV0438	SV ABNORMAL CURRENT	Motor overcurrent
SV0439	PS OVER VOLT. DC LINK	The DC link voltage is too high.
SV0440	PS EXCESS-REGENERATION2	Excessive generative discharge
SV0441	ABNORMAL CURRENT OFFSET	The digital servo software detected an abnormality in the motor current detection circuit.
SV0442	PS PRE-CHARGE FAILURE	The pre-charge circuit for the DC link is abnormal.
SV0443	PS INTERNAL FAN FAILURE	Internal cooling fan failure.
SV0444	SV INTERNAL FAN FAILURE	Internal cooling fan failure.
SV0445	SOFT DISCONNECT ALARM	The digital servo software detected a disconnected Pulsecoder.
SV0446	HARD DISCONNECT ALARM	The hardware detected a disconnected built-in Pulsecoder.
SV0447	HARD DISCONNECT(EXT)	The hardware detected a disconnected separate detector.
SV0448	UNMATCHED FEEDBACK ALARM	The sign of the feedback signal from the standalone detector is opposite to that from the feedback signal from the built-on Pulsecoder.
SV0449	SV IPM ALARM	The IPM (Intelligent Power Module) detected an alarm.
SV0453	SPC SOFT DISCONNECT ALARM	Software disconnection alarm of the built-in Pulsecoder. Turn off the power to the CNC, then remove and insert the Pulsecoder cable. If this alarm is issued again, replace the Pulsecoder.
SV0454	ILLEGAL ROTOR POS DETECT	The magnetic pole detection function terminated abnormally. The magnetic pole could not be detected because the motor did not run.
SV0456	ILLEGAL CURRENT LOOP	An attempt was made to set the current loop that could not be set. The amplifier pulse module in use does not comply with HIGH SPEED HRV. Or, requirements to control are not satisfied in the system.
SV0458	CURRENT LOOP ERROR	The specified current loop differs from the actual current loop.
SV0459	HI HRV SETTING ERROR	For two axes whose servo axis numbers (parameter No. 1023) are consecutively even and odd numbers, HIGH SPEED HRV control is possible for one axis and impossible for the other.
SV0460	FSSB DISCONNECT	The FSSB connection was discontinued. Probable causes are: 1. The FSSB connection cable was disconnected or broken. 2. The amplifier was turned off . 3. In the amplifier, the low-voltage alarm occurred.
SV0462	SEND CNC DATA FAILED	The correct data could not be received on a slave side because of the FSSB communication error.
SV0463	SEND SLAVE DATA FAILED	The correct data could not be received in the servo software because of the FSSB communication error.
SV0465	READ ID DATA FAILED	A read of the ID information for the amplifier has failed at power-on.

Number	Message	Description
SV0466	MOTOR/AMP. COMBINATION	The maximum current of an amplifier is different to that of a motor. Probable causes are: 1. The connection command for an amplifier is incorrect. 2. The parameter No.2165 setting is incorrect
SV0468	HI HRV SETTING ERROR(AMP)	An attempt was made to set up HIGH SPEED HRV control for use when the controlled axis of an amplifier for which HIGH SPEED HRV control could not be used.
SV0474	EXCESS ERROR(STOP:SV )	The servo detected that the positional deviation during a stop exceeded the setting (parameters Nos. 1839 and 1842) in the n-axis.
SV0475	EXCESS ERROR(MOVE:SV)	The servo detected that the positional deviation during a travel exceeded the setting (parameters Nos. 1838 and 1841) in the n-axis.
SV0476	ILLEGAL SPEED CMD.(SV )	The servo detected that the speed command exceeded the safety speed (parameters Nos. 13821 to 13824 (during position control) or parameters Nos. 13826 to 13829 (during speed control)) during safety monitoring (when safety monitoring request signal *VLDVx is 0) in the n-axis. Keep the safety speed.
SV0477	ILLEGAL MACHINE POS.(SV)	The servo detected that the machine position fell outside the safety area (setting by parameters Nos. 13831 to 13838) during safety monitoring (when safety monitoring request signal *VLDVx is 0) in the n-axis. Keep the safety area. A machine position check is performed only on the axis for which the reference position has been established. The axis for which the reference position is not established is not subjected to a machine position check.
SV0478	ILLEGAL AXIS DATA(SV)	The servo detected that an error occurred during transfer of axis data in the n-axis. When an alarm occurred because the configuration of the servo amplifier was changed, set the axis number for the servo amplifier (set bit 4 of parameter No. 2212 of the corresponding axis to 1 and then 0 and turn off the power of the entire system). When using a multi-axis amplifier, this operation may not clear the alarm. In this case, repeat this operation for the axes on which the alarm persists. If an alarm occurs due to a cause other than the above, replace the servo amplifier.
SV0481	SAFETY PARAM ERROR(SV)	The servo detected that a safety parameter error occurred in the n-axis.
SV0484	SAFETY FUNCTION ERROR(SV)	A safety function error related to the servo was detected in the n-axis. - The servo or CNC detected that the safety function was not executed in the servo. - The result of a servo safety function check did not match the result of a CNC safety function check. - An error occurred during a test of the CPU of the servo. - An error occurred during a check of RAM of the servo.
SV0488	SELF TEST OVER TIME	An MCC interruption test was not complete within the set period of time (parameter No. 1946). Check the MCC contact.
SV0489	SAFETY PARAM ERROR(CNC)	The CNC detected that a safety parameter error occurred in the n-axis.

Number	Message	Description
SV0490	SAFETY FUNCTION ERROR(CNC)	A CNC safety function error occurred in the n-axis. <ul style="list-style-type: none"> <li>- The servo detected that the safety function was not executed in the CNC.</li> <li>- The result of a servo safety function check did not match the result of a CNC safety function check.</li> </ul>
SV0494	ILLEGAL SPEED CMD.(CNC)	The CNC detected that the speed command exceeded the safety speed (parameters Nos. 13821 to 13824 (during position control) or parameters Nos. 13826 to 13829 (during speed control)) during safety monitoring (when safety monitoring request signal *VLDVx is 0) in the n-axis. Keep the safety speed.
SV0496	ILLEGAL AXIS DATA(CNC)	The CNC detected that an error occurred during transfer to axis data. <p>When an alarm occurred because the configuration of the servo amplifier was changed, set the axis number for the servo amplifier (set bit 4 of parameter No. 2212 of the corresponding axis to 1 and 0 again and turn off the power of the entire system). When using a multi-axis amplifier, this operation may not clear the alarm. In this case, repeat this operation for the axes on which the alarm persists.  If an alarm occurs due to a cause other than the above, replace the servo amplifier.</p>
SV0498	AXIS NUMBER NOT SET(CNC)	The CNC detected that the axis number of the n-axis was not set for the servo amplifier. The axis number is set automatically, so turn off the power of the entire system.
SV0600	SV DC LINK OVER CURRENT	DC link overcurrent.
SV0601	SV EXTERNAL FAN FAILURE	Radiator cooling fan failure.
SV0602	SV OVERHEAT	The servo amplifier radiator has overheated.
SV0603	SV IPM ALARM(OH)	The IPM (Intelligent Power Module) detected an overheat alarm.
SV0604	AMP COMMUNICATION ERROR	The communication between Servo Amplifier (SV) and Common Power Supply (PS) is in error.
SV0605	PS EXCESS-REGENERATION1	The motor regenerative power is too much.
SV0606	PS EXTERNAL FAN FAILURE	External radiator cooling fan failure.
SV0607	PS IMPROPER INPUT POWER	An abnormality was found with the input power supply.
SV0646	ABNORMAL ANALOG SIGNAL(EXT)	An error occurred in the analog 1Vp-p output of the separate detector. The separate detector, cable, or separate detector interface unit may be failed.
SV0652	TEMP.ERROR	Communication between the separate detector interface unit and temperature sensor was disconnected.
SV0654	DB RELAY FAILURE	A failure occurs in the dynamic brake relay of the servo amplifier. Replace the amplifier.
SV1025	V_READY ON (INITIALIZING )	The ready signal (VRDY) of the velocity control which should be OFF is ON while the servo control is ON.
SV1026	ILLEGAL AXIS ARRANGE	The parameter for servo axis arrange is not set correctly. <ul style="list-style-type: none"> <li>- Parameter No. 1023 (servo axis number of each axis) is set to a negative value or a duplicate value.</li> <li>- The settings for parameter No. 1023 (servo axis number of each axis) were made with a certain setting skipped among 1 to 6, 9 to 14, or 17 to 22.</li> <li>- A setting of a multiple of 8 or a multiple of 8 minus 1 was made.</li> </ul>
SV1055	ILLEGAL TANDEM AXIS	In tandem control, the setting of the parameter No. 1023 is incorrect. In tandem control, the setting of the bit 6 (TDM) of parameter No. 1817 is incorrect.

Number	Message	Description
SV1067	FSSB:CONFIGURATION ERROR(SOFT)	An FSSB configuration error occurred (detected by software). The connected amplifier type is incompatible with the FSSB setting value.
SV1068	DUAL CHECK SAFETY ALARM	An alarm that turns off the MCC of the entire system occurred in the Dual Check Safety function.
SV1069	EXCESS ERROR(SERVO OFF:CNC)	The CNC detected that the positional deviation during servo-off exceeded the set value (parameter No. 1840) in the n-axis.
SV1070	EXCESS ERROR(SERVO OFF:SV)	The servo detected that the positional deviation during servo-off exceeded the set value (parameter No. 1840) in the n-axis.
SV1071	EXCESS ERROR(MOVE:CNC)	The CNC detected that the positional deviation during a travel exceeded the set value (parameters Nos. 1838 and 1841) in the n-axis.
SV1072	EXCESS ERROR(STOP:CNC)	The CNC detected that the positional deviation during a stop exceeded the set value (parameters Nos. 1839 and 1842) in the n-axis.
SV1100	S-COMP. VALUE OVERFLOW	The amount of compensation for the straightness exceeded a maximum value of 32767.
SV5134	FSSB:OPEN READY TIME OUT	In the initialization, the FSSB could not be in an open ready state. The axis card is thought to be defective.
SV5136	FSSB:NUMBER OF AMP. IS INSUFFICIENT	The number of amplifier identified by the FSSB is insufficient than the number of control axes. Or, the setting of the number of axes or the amplifier connection is in error.
SV5137	FSSB:CONFIGURATION ERROR	An FSSB configuration error occurred. The connecting amplifier type is incompatible with the FSSB setting value.
SV5139	FSSB:ERROR	Servo initialization has not completed successfully. It is probable that an optical cable failed or a connection between the amplifier and another module failed.
SV5197	FSSB:OPEN TIME OUT	The initialization of the FSSB was completed, but it could not be opened. Or, the connection between the CNC and the amplifier in is incorrect.
SV5311	FSSB:ILLEGAL CONNECTION	Different current loops (HRV) are set for FSSB lines. Specify the same current loop for the FSSB lines.

**(6) Overtravel alarms (OT alarm)**

Number	Message	Description
OT0500	+ OVERTRAVEL ( SOFT 1 )	Exceeded the positive side stored stroke check 1.
OT0501	- OVERTRAVEL ( SOFT 1 )	Exceeded the negative side stored stroke check 1.
OT0502	+ OVERTRAVEL ( SOFT 2 )	Exceeded the positive side stored stroke check 2. Or, in the chuck tail stock barrier, an entry to the inhibited area was made during movement in the positive direction.
OT0503	- OVERTRAVEL ( SOFT 2 )	Exceeded the negative side stored stroke check 2. Or, in the chuck tail stock barrier, an entry to the inhibited area was made during movement in the negative direction.
OT0504	+ OVERTRAVEL ( SOFT 3 )	Exceeded the positive side stored stroke check 3.
OT0505	- OVERTRAVEL ( SOFT 3 )	Exceeded the - side stored stroke check 3.



Number	Message	Description
OT0506	+ OVERTRAVEL ( HARD )	The stroke limit switch in the positive direction was triggered. This alarm is generated when the machine reaches the stroke end. When this alarm is not generated, feed of all axes is stopped during automatic operation. During manual operation, only the feed of the axis on which the alarm occurred is stopped.
OT0507	- OVERTRAVEL ( HARD )	The stroke limit switch in the negative direction was triggered. This alarm is generated when the machine reaches the stroke end. When this alarm is not generated, feed of all axes is stopped during automatic operation. During manual operation, only the feed of the axis on which the alarm occurred is stopped.
OT0508	INTERFERENCE:+	A tool moving in the positive direction along the n axis has fouled another tool post.
OT0509	INTERFERENCE:-	A tool moving in the negative direction along the n axis has fouled another tool post.
OT0510	+ OVERTRAVEL ( PRE-CHECK )	The tool exceeded the limit in the negative direction during the stroke check before movement.
OT0511	- OVERTRAVEL ( PRE-CHECK )	The tool exceeded the limit in the positive direction during the stroke check before movement.
OT0514	(n) INTERFERENCE:+	An interference occurred on the plus side of the n-axis in a rotation area interference check.
OT0515	(n) INTERFERENCE:-	An interference occurred on the minus side of the n-axis in a rotation area interference check.
OT0518	(n)+: INTERFERE ( [Target name 1],[ Target name 2])	A check made for interference between [Target name1] and [Target name2] detected interference on the + side of axis n. n represents the name of the axis with which an alarm is issued.
OT0519	(n)-: INTERFERE ([Target name 1],[ Target name 2])	A check made for interference between [Target name1] and [Target name2] detected interference on the - side of axis n. n represents the name of the axis with which an alarm is issued.
OT1710	ILLEGAL ACC. PARAMETER (OPTIMUM TORQUE ACC/DEC)	The permissible acceleration parameter for the optimum torque acceleration/deceleration is in error. A possible cause is either of the following: (1) The ratio of a negative acceleration to a positive acceleration is not more than the limit value. (2) The time to reduce to a velocity of 0 exceeded the maximum time.

### (7) Memory file alarms (IO alarm)

Number	Message	Description
IO1001	FILE ACCESS ERROR	The resident-type file system could not be accessed as an error occurred in the resident-type file system.
IO1002	FILE SYSTEM ERROR	The file could not be accessed as an error occurred in the CNC file system.
IO1030	CHECK SUM ERROR	The checksum of the CNC part program storage memory is incorrect.
IO1032	MEMORY ACCESS OVER RANGE	Accessing of data occurred outside the CNC part program storage memory range.

Number	Message	Description
IO1104	OVER MAXIMUM TOOL LIFE PAIRS	The maximum number of tool life management pairs is exceeded. Modify the setting of the maximum number of tool life management pairs in parameter No. 6813.

**(8) Alarms requiring power to be turned off (PW alarm)**

Number	Message	Description
PW0000	POWER MUST BE OFF	A parameter was set for which the power must be turned OFF then ON again.
PW0001	X-ADDRESS(*DEC) IS NOT ASSIGNED.	The X address of the PMC could not be assigned correctly. This alarm may occur in the following case: - During the setting of parameter No. 3013, the X address could not be assigned correctly for the deceleration dog (*DEC) for a return to the reference position.
PW0002	PMC address is not correct(Axis).	The address to assign the axis signal is incorrect. This alarm may occur in the following case: - The parameter No.3021 setting is incorrect.
PW0003	PMC address is not correct(SPINDLE).	The address to assign the spindle signal is incorrect. This alarm may occur in the following case: - The parameter No.3022 setting is incorrect.
PW0004	SETTING THE LOADER SYSTEM PATH IS NOT CORRECT.	The loader system could not be assigned correctly. The parameter No. 984 setting is incorrect. - The number of loader systems and the number of systems specified to the loader system in the bit 0 (LCP) of parameter No. 0984 does not match. - The bit 0 (LCP) of parameter No. 0984 of the system 1 is set to 1.
PW0006	POWER MUST BE OFF (ILL-EXEC-CHK)	The malfunction prevention function detected an alarm to require the power off.
PW0007	X-ADDRESS(SKIP) IS NOT ASSIGNED	The X address of PMC could not be assigned correctly. Possible causes are: - During the set of parameter No. 3012, the skip signal of the X address was not assigned correctly. - During the set of parameter No. 3019, the address other than the skip signal of the X address was not assigned correctly.
PW0008	CPU SELF TEST ERROR(DCS PMC)	On the DCS PMC side: - An error was detected by the CPU self diagnosis function. - An error was detected by the RAM check function.
PW0009	CPU SELF TEST ERROR(PMC)	On the PMC side: - An error was detected by the CPU self diagnosis function. - An error was detected by the RAM check function.
PW0010	SAFE I/O CROSS CHECK ERROR(DCS PMC)	On the DCS PMC side, an error was detected by the I/O cross check function in system-defined safety-related DI/DO.
PW0011	SAFE I/O CROSS CHECK ERROR(PMC)	On the PMC side, an error was detected by the I/O cross check function in system-defined safety-related DI/DO.
PW0012	USER I/O CROSS CHECK ERROR(DCS PMC)	On the DCS PMC side, an error was detected by the I/O cross check function in user-defined safety-related DI/DO.
PW0013	USER I/O CROSS CHECK ERROR(PMC)	On the PMC side, an error was detected by the I/O cross check function in user-defined safety-related DI/DO.
PW0014	CPU TEST ALARM (CNC)	An error occurred in a test of the CPU of the CNC.

Number	Message	Description
PW0015	SAFETY PARAM ERROR	The CNC detected that an error occurred in a safety parameter for other than servo axes or spindle axes.
PW0016	RAM CHECK ERROR	An error was detected in a RAM check of the CNC.
PW0017	INEXECUTION OF SAFETY FUNCTIONS	The safety function was not executed normally in the CNC.
PW0018	CRC CHECK ERROR	An error was detected in a CRC check of the CNC.
PW0020	HSP PARAMETER ERROR(MPATH)	The total value specified for all paths in parameter No. 11604 exceeds 600 (1000).
PW1102	ILLEGAL PARAMETER (I-COMP.)	The parameter for setting slope compensation is incorrect. This alarm occurs in the following cases: <ul style="list-style-type: none"> <li>- When the number of pitch error compensation points on the axis on which slope compensation is executed exceeds 128 between the most negative side and most positive side</li> <li>- When the size relationship between the slope compensation point Nos. is incorrect</li> <li>- When the slope compensation point is not located between the most negative side and most positive side of pitch error compensation</li> <li>- When the compensation per compensation point is too small or too great.</li> </ul>
PW1103	ILLEGAL PARAMETER (S-COMP.128)	The parameter for setting 128 straightness compensation points or the parameter compensation data is incorrect,
PW1104	ILLEGAL PARAMETER (3-D MACHINE POSITION COMPENSATION.)	A parameter for setting 3-dimensional machine position compensation is incorrect.
PW5046	ILLEGAL PARAMETER (S-COMP.)	The setting of a parameter related to straightness compensation contains an error. Possible causes include: <ul style="list-style-type: none"> <li>- A non-existent axis number is set in a moving or compensation axis parameter.</li> <li>- More than 128 pitch error compensation points are set between the furthest points in the negative and position regions.</li> <li>- The straightness compensation point numbers do not have correct magnitude relationships.</li> <li>- No straightness compensation point is found between the furthest pitch error compensation point in the negative region and that in the positive region.</li> <li>- The compensation per compensation point is either too large or too small.</li> </ul>
PW5390	R-ADDRESS SETTING IS ILLEGAL	The start address or the set range of the PMC R addresses set by parameters Nos.13541 and 13542 is invalid.

**(9) Spindle alarms (SP alarm)**

Number	Message	Description
SP0740	RIGID TAP ALARM : EXCESS ERROR	The positional deviation of the stopped spindle has exceeded the set value during rigid tapping.
SP0741	RIGID TAP ALARM : EXCESS ERROR	The positional deviation of the moving spindle has exceeded the set value during rigid tapping.
SP0742	RIGID TAP ALARM : LSI OVERFLOW	An LSI overflow has occurred for the spindle during rigid tapping.

Number	Message	Description
SP0752	SPINDLE MODE CHANGE ERROR	This alarm is generated if the system does not properly terminate a mode change. The modes include the Cs contour control, spindle positioning, rigid tapping, and spindle control modes. The alarm is activated if the spindle control unit does not respond correctly to the mode change command issued by the NC.
SP0754	ABNORMAL TORQUE	An abnormal load was detected in a spindle motor. The alarm can be canceled by RESET.
SP0755	SAFETY FUNCTION ERROR	The CNC CPU detected that the safely function of the n-th spindle was not executed. Alternatively, the result of a CNC safety function check did not match the result of a spindle safety function check.
SP0756	ILLEGAL AXIS DATA	The CNC CPU detected an error during transfer of spindle data in the n-th spindle. When this alarm is issued because the configuration of the spindle amplifiers was changed, set the spindle number for the spindle amplifier (set bit 7 of parameter No. 4541 to 1 and then 0, and turn the power to the entire system off).
SP0757	SAFETY SPEED OVER	The CNC CPU detected that during safety monitoring (when safety monitoring request signal *VLDPs is 0), the spindle motor speed was greater than the safety speed (parameter No. 4372, 4438, 4440, or 4442) on the n-th spindle. Operate within the safety speed.
SP1202	SPINDLE SELECT ERROR	In a multi spindle control, the spindle number other than the valid spindle number was selected by a position coder select signal. An attempt was made to select the spindle number of the system having no valid spindle.
SP1210	TOOL CHANGE SP MOTION OVERFLOW	The amount of distribution to a spindle is too much. (specific to the FANUC ROBODRILL)
SP1211	TOOL CHANGE SP ORTN EXCESS ERROR	During a tool change, a too much orientation error was detected for the spindle. (specific to the FANUC ROBODRILL)
SP1212	TOOL CHANGE SP MOVE EXCESS ERROR	During a tool change, a too much moving error was detected for the spindle. (specific to the FANUC ROBODRILL)
SP1213	TOOL CHANGE SP STOP EXCESS ERROR	During a tool change, a too much stop error was detected for the spindle. (specific to the FANUC ROBODRILL)
SP1214	TOOL CHANGE SP ILLEGAL SEQUENCE	During changing tools, an abnormal spindle sequence was detected. (specific to the FANUC ROBODRILL)
SP1220	NO SPINDLE AMP.	Either the cable connected to a serial spindle amplifier is broken, or the serial spindle amplifier is not connected.
SP1221	ILLEGAL MOTOR NUMBER	The spindle No. and the motor No. are incorrectly matched.
SP1224	ILLEGAL SPINDLE-POSITION CODER GEAR RATIO	The spindle-position coder gear ratio was incorrect.
SP1225	CRC ERROR (SERIAL SPINDLE)	A CRC error (communications error) occurred in communications between the CNC and the serial spindle amplifier.
SP1226	FRAMING ERROR (SERIAL SPINDLE)	A framing error occurred in communications between the CNC and the serial spindle amplifier.
SP1227	RECEIVING ERROR (SERIAL SPINDLE)	A receive error occurred in communications between the CNC and the serial spindle amplifier.
SP1228	COMMUNICATION ERROR (SERIAL SPINDLE)	A communications error occurred between the CNC and the serial spindle amplifier.

Number	Message	Description
SP1229	COMMUNICATION ERROR SERIAL SPINDLE AMP.	A communications error occurred between serial spindle amplifiers (motor Nos. 1 and 2, or motor Nos. 3–4).
SP1231	SPINDLE EXCESS ERROR (MOVING)	The position deviation during spindle rotation was greater than the value set in parameters.
SP1232	SPINDLE EXCESS ERROR (STOP)	The position deviation during spindle stop was greater than the value set in parameters.
SP1233	POSITION CODER OVERFLOW	The error counter/speed instruction value of the position coder overflowed.
SP1234	GRID SHIFT OVERFLOW	Grid shift overflowed.
SP1240	DISCONNECT POSITION CODER	The analog spindle position coder is broken.
SP1241	D/A CONVERTER ERROR	The D/A converter for controlling analog spindles is erroneous.
SP1243	ILLEGAL SPINDLE PARAMETER SETTING(GAIN)	The setting for the spindle position gain is incorrect.
SP1244	MOTION VALUE OVERFLOW	The amount of distribution to a spindle is too much
SP1245	COMMUNICATION DATA ERROR	A communication data error was detected on the CNC.
SP1246	COMMUNICATION DATA ERROR	A communication data error was detected on the CNC.
SP1247	COMMUNICATION DATA ERROR	A communication data error was detected on the CNC.
SP1700	SAFETY PARAM ERROR	The CNC detected that a safety parameter error occurred in the n-th spindle.
SP1969	SPINDLE CONTROL ERROR	An error occurred in the spindle control software.
SP1970	SPINDLE CONTROL ERROR	Initialization of spindle control ended in error.
SP1971	SPINDLE CONTROL ERROR	An error occurred in the spindle control software.
SP1972	SPINDLE CONTROL ERROR	An error occurred in the spindle control software.
SP1974	ANALOG SPINDLE CONTROL ERROR	An error occurred in the spindle control software.
SP1975	ANALOG SPINDLE CONTROL ERROR	An position coder error was detected on the analog spindle.
SP1976	SERIAL SPINDLE COMMUNICATION ERROR	The amplifier No. could not be set to the serial spindle amplifier.
SP1977	SERIAL SPINDLE COMMUNICATION ERROR	An error occurred in the spindle control software.
SP1978	SERIAL SPINDLE COMMUNICATION ERROR	A time-out was detected during communications with the serial spindle amplifier.
SP1979	SERIAL SPINDLE COMMUNICATION ERROR	The communications sequence was no longer correct during communications with the serial spindle amplifier.
SP1980	SERIAL SPINDLE AMP. ERROR	Defective SIC-LSI on serial spindle amplifier
SP1981	SERIAL SPINDLE AMP. ERROR	An error occurred during reading of the data from SIC-LSI on the analog spindle amplifier side.
SP1982	SERIAL SPINDLE AMP. ERROR	An error occurred during reading of the data from SIC-LSI on the serial spindle amplifier side.
SP1983	SERIAL SPINDLE AMP. ERROR	Could not clear on the spindle amplifier side.
SP1984	SERIAL SPINDLE AMP. ERROR	An error occurred during re-initialization of the spindle amplifier.
SP1985	SERIAL SPINDLE CONTROL ERROR	Failed to automatically set parameters
SP1986	SERIAL SPINDLE CONTROL ERROR	An error occurred in the spindle control software.
SP1987	SERIAL SPINDLE CONTROL ERROR	Defective SIC-LSI on the CNC
SP1988	SPINDLE CONTROL ERROR	An error occurred in the spindle control software.
SP1989	SPINDLE CONTROL ERROR	An error occurred in the spindle control software.
SP1996	ILLEGAL SPINDLE PARAMETER SETTING	The spindle was assigned incorrectly. Check to see the following parameter. (No.3716 or 3717)
SP1998	SPINDLE CONTROL ERROR	An error occurred in the spindle control software.
SP1999	SPINDLE CONTROL ERROR	An error occurred in the spindle control software.

**(10) Overheat alarms (OH alarm)**

Number	Message	Description
OH0700	LOCKER OVERHEAT	CNC cabinet overheat

Number	Message	Description
OH0701	FAN MOTOR STOP	PCB cooling fan motor abnormality
OH0704	OVERHEAT	Spindle overheat due to detection of changes in the spindle speed <ul style="list-style-type: none"> <li>- When the cutting load is large, offload the cutting conditions.</li> <li>- Check if the cutting tool became dull.</li> <li>- Check if the spindle amplifier malfunctions.</li> </ul>

**(11) Other alarms (DS alarm)**

Number	Message	Description
DS0001	SYNC EXCESS ERROR (POS DEV)	In feed axis synchronization control, the difference in the amount of positional deviation between the master and slave axes exceeded the parameter No. 8323 setting value. This alarm occurs for the master or slave axis.
DS0002	SYNC EXCESS ERROR ALARM 1	In feed axis synchronization control, the difference in the amount of synchronization between the master and slave axes exceeded the parameter No. 8331 setting value. This alarm occurs only for the slave axis.
DS0003	SYNCHRONIZE ADJUST MODE	The system is in the synchronize adjust mode.
DS0004	EXCESS MAXIMUM FEEDRATE	The malfunction prevention function detected the command in which a value exceeding the maximum speed was specified.
DS0005	EXCESS MAXIMUM ACCELERATION	The malfunction prevention function detected the command in which a value exceeding the maximum acceleration was specified.
DS0006	ILLEGAL EXECUTION SEQUENCE	The malfunction prevention function detected an illegal execution sequence.
DS0007	ILLEGAL EXECUTION SEQUENCE	The malfunction prevention function detected an illegal execution sequence.
DS0008	ILLEGAL EXECUTION SEQUENCE	The malfunction prevention function detected an illegal execution sequence.
DS0009	ILLEGAL EXECUTION SEQUENCE	The malfunction prevention function detected an illegal execution sequence.
DS0010	ILLEGAL REFERENCE AREA	The malfunction prevention function detected an invalid reference area.
DS0011	ILLEGAL REFERENCE AREA	The malfunction prevention function detected an invalid reference area.
DS0012	ILLEGAL REFERENCE AREA	The malfunction prevention function detected an invalid reference area.
DS0013	ILLEGAL REFERENCE AREA	The malfunction prevention function detected an invalid reference area.
DS0014	TOOL CHANGE DETECT MACHINE LOCK	A machine lock is turned on for the Z axis for which the tool is being changed.
DS0015	TOOL CHANGE DETECT MIRROR IMAGE	A mirror image is turned on for the Z axis for which the tool is being changed.
DS0016	SERIAL DCL:FOLLOW-UP ERROR	(1) The settings of parameters Nos.1883 and 1884 fall outside the range. (2) The current position at establishment of the origin subtracted by the distance between the reference positions (detection unit) exceeded $\pm 2147483647$ . Change the current position or reference position to prevent this situation.
DS0017	SERIAL DCL:REF-POS ESTABLISH ERR	The travel amount at the FL speed at establishment of the origin exceeded the setting of parameter No. 14010.

Number	Message	Description
DS0018	SERIAL DCL:MISMATCH(SSYNC CTRL)	Of the master and slave axes for feed axis synchronous control, one axis is a linear scale with the origin and the other is not a linear scale with the origin. In such a configuration, the feed axis synchronous control selection signal (SYNC<Gn138> or SYNCJ <Gn140>) needs to be set to 0 to establish the origin.
DS0019	SERIAL DCL:MISMATCH(ANGL-AXIS)	In angular axis control, one of the angular axis and the Cartesian axis is a linear scale with an origin, while the other is not a linear scale with an origin. Angular axis control cannot be used in such a configuration.
DS0020	REFERENCE RETURN INCOMPLETE	An attempt was made to perform an automatic return to the reference position on the perpendicular axis before the completion of a return to the reference position on the angular axis. However, this attempt failed because a manual return to the reference position during angular axis control or an automatic return to the reference position after power-up was not commanded. First, return to the reference position on the angular axis, then return to the reference position on the perpendicular axis.
DS0022	DUAL CHECK SAFETY IS NOT WORKED	Bit 6 (DCE) of parameter No. 1902 has set the Dual Check Safety function to be disabled.
DS0023	ILLEGAL PARAMETER (I-COMP VAL)	The setting of the inclination compensation parameter is incorrect. The compensation per compensation point is too large or too small.
DS0024	UINT SIGNAL WAS ILLEGALLY INPUT	An interruption custom macro was started during movement to the machining restart position at the dry run speed.
DS0025	G60 CANNOT BE EXECUTED	The state of a mirror image is different between the time when look-ahead of a block for unidirectional positioning was performed and the time when execution of the block was started, so unidirectional positioning cannot be performed. Modify the program.
DS0026	MISMATCH OF ANGULAR AXIS(D.C.S)	On angular axis control, one of the angular/perpendicular axes is the scale with ref-pos, and the other of them is not the scale with ref-pos. Such system is not admired.
DS0027	MISMATCH OF SYNCHRONOUS AXIS(D.C.S)	Master/slave axes of axis synchronous control, one of them is the linear scale with distance-coded reference marks, and the other of them is not the linear scale with distance-coded reference marks. Please establish reference position with the input signal SYNCn<G138>, SYNCJn<G140> or parameter setting to 0.
DS0029	UNAVAILABLE ROT AXIS MOVE IN TPC	In tool posture control, the rotation axis fell outside the set operation range (parameters Nos. 19741 to 19744). Review the machine configuration and command.
DS0030	TOOL DIRC CMP IMPOSSIBLE	When tool center point control is performed in the angular surface machining command mode or workpiece placement error compensation is performed in a 5-axis cutting machine, if settings are made to make compensation in the tool direction (bit 0 (RCM) of parameter No. 11200 is 1), the position of the rotation axis could not be obtained.

Number	Message	Description
DS0050	TOO MANY SIMULTANEOUS AXES	A movement was performed along more axes than can be controlled by simultaneous axis control. Check whether a command in the program is specified for more axes than can be controlled by simultaneous axis control.
DS0059	SPECIFIED NUMBER NOT FOUND	[External data I/O] The No. specified for a program No. or sequence No. search could not be found. There was an I/O request issued for a pot No. or offset (tool data), but either no tool numbers have been input since power ON or there is no data for the entered tool No. [External workpiece No. search] The program corresponding to the specified workpiece No. could not be found.
DS0069	MISSING THE MOVE COMMAND	A move command is not specified in the next block to the synchronous start block.
DS0070	SUPERIMPOSE FOR HIGH-SPEED CYCLE CANNOT BE USED	Superimposed control for high-speed cycle machining is not enabled. Alternatively, the status is not the advanced superimposition state.
DS0071	START OR RELEASE CANNOT BE DONE	1) To start or cancel the inter-path flexible synchronous mode, the tool must be stopped along all axes. 2) To start or cancel advanced superimposition, movement along axes must stop.
DS0072	MANUAL REFERENCE RETURN CANNOT BE DONE	Manual reference position return cannot be performed in the advanced superimposition state.
DS0131	TOO MANY MESSAGE	An attempt was made to display an external operator message or external alarm message, but five or more displays were required simultaneously.
DS0132	MESSAGE NUMBER NOT FOUND	An attempt to cancel an external operator message or external alarm message failed because the specified message number was not found.
DS0133	TOO LARGE NUMBER	A value other than 0 to 4095 was specified as the external operator message or the external alarm message number.
DS0300	APC ALARM: NEED REF RETURN	A setting to zero position for the absolute position detector (association with reference position and the counter value of the absolute position detector) is required. Perform the return to the reference position. This alarm may occur with other alarms simultaneously. In this case, other alarms must be handled first.
DS0306	APC ALARM: BATTERY VOLTAGE 0	The battery voltage of the absolute position detector has dropped to a level at which data can no longer be held. Or, the power was supplied to the Pulsecoder for the first time. The battery or cable is thought to be defective. Replace the battery with the machine turned on.
DS0307	APC ALARM: BATTERY LOW 1	The battery voltage of the absolute position detector has dropped to a level at which a replacement is required. Replace the battery with the machine turned on.
DS0308	APC ALARM: BATTERY LOW 2	The battery voltage of the absolute position detector dropped to a level at which a replacement was required in the past. (including during power off) Replace the battery with the machine turned on.



Number	Message	Description
DS0309	APC ALARM: REF RETURN IMPOSSIBLE	An attempt was made to set the zero point for the absolute position detector by MDI operation when it was impossible to set the zero point. Rotate the motor manually at least one turn, and set the zero position of the absolute position detector after turning the CNC and servo amplifier off and then on again.
DS0310	NOT ON RETURN POINT	The return position recorded during retraction is not reached during recovery. The position may be displaced during recovery due to a machine lock or mirror image. Perform the operation again after making a reset.
DS0405	ZERO RETURN END NOT ON REF	The axis specified in automatic zero return was not at the correct zero point when positioning was completed. Perform zero return from a point whose distance from the zero return start position to the zero point is 2 or more revolutions of the motor. Other probable causes are: - The positional deviation after triggering the deceleration dog is less than 128. - Insufficient voltage or malfunctioning Pulsecoder.
DS0608	SV COOLING FAN FAILURE	Internal agitating fan failure.
DS0609	SV RADIATOR FAN FAILURE	Radiator cooling fan failure.
DS0610	PS INTERNAL FAN FAILURE	Internal agitating fan failure.
DS0611	PS EXTERNAL FAN FAILURE	External radiator cooling fan failure.
DS0612	PS OVERLOAD	Overheat
DS0613	PS IMPROPER INPUT POWER	Input power supply fault
DS0651	ACC.ERROR	Communication between the separate detector interface unit and acceleration sensor was disconnected.
DS1120	UNASSIGNED ADDRESS (HIGH)	The upper 4 bits (EIA4 to EIA7) of an external data I/O interface address signal are set to an undefined address (high bits).
DS1121	UNASSIGNED ADDRESS (LOW)	The lower 4 bits (EIA0 to EIA3) of an external data I/O interface address signal are set to an undefined address (low bits).
DS1124	OUTPUT REQUEST ERROR	OUTPUT REQUEST ERROR An output request was issued during external data output, or an output request was issued for an address that has no output data.
DS1128	DI.EIDLL OUT OF RANGE	The numerical value input by external data input signals ED0 to ED31 has exceeded the permissible range.
DS1130	SEARCH REQUEST NOT ACCEPTED	No requests can be accepted for a program No. or a sequence No. search as the system is not in the memory mode or the reset state.
DS1131	EXT-DATA ERROR (OTHER)	[External Data I/O] An attempt was made to input tool data for tool offset by a tool No. during loading by the G10 code.
DS1150	A/D CONVERT ALARM	A/D converter malfunction
DS1184	PARAMETER ERROR IN TORQUE	An invalid parameter was set for torque control. The torque constant parameter is set to "0".
DS1185	OVER MAXIMUM FEED	The maximum cutting feedrate or rapid traverse feedrate was exceeded in G54.3.

Number	Message	Description
DS1448	ILLEGAL PARAMETER (D.C.S.)	The setting value of parameter for reference marks is satisfied the following any conditions. <ul style="list-style-type: none"> <li>- The absolute-position detection function is enabled.</li> <li>- Either parameter 1821 (mark-1 interval) or parameter 1882 (mark-2 interval) is set to 0.</li> <li>- Parameters 1821 and 1882 have identical settings.</li> <li>- The difference between the settings made for parameters 1821 and 1882 is greater than or equal to twice either setting.</li> <li>- The setting value of parameters 1883 and 1884 are over the valid data range.</li> </ul>
DS1449	REFERENCE MARK ARE DIFFERENT FROM PARAMETER	In case of distance coded linear scale I/F, the actual interval of reference marks is different from parameters Nos. 1821 and 1882 setting value.
DS1450	ZERO RETURN NOT FINISHED	1st reference position return (CDxX7 to CDxX0: 17h (Hex)) was specified when the manual reference position return was not executed with the reference position return function enabled (bit 0 (ZRN) of parameter No. 1005 set to "0").
DS1451	IMPROPER PMC AXIS COMMAND	The PMC axes cannot be controlled in this state.
DS1512	EXCESS VELOCITY	The feedrate of the linear axis during polar coordinate interpolation exceeded the maximum cutting feedrate.
DS1514	ILLEGAL MOTION IN G12.1 MODE	In a hypothetical axis direction compensation during the polar coordinate interpolation mode, an attempt is made to travel to the area in which the travel cannot be made.
DS1553	EXCESS VELOCITY IN G43.4/G43.5	The axis rate was attempt to exceed the maximum cutting feedrate and travel by the pivot tool length compensation.
DS1710	ILLEGAL ACC. PARAMETER (OPTIMUM TORQUE ACC/DEC)	There are errors in the parameters of permissible acceleration for Optimum Torque Acceleration/Deceleration. One of the following is the cause. <ol style="list-style-type: none"> <li>1) The ratio of the acceleration for deceleration to the acceleration for the acceleration is lower than the limited value.</li> <li>2) The time to decelerate to 0 is larger than the maximum.</li> </ol>
DS1711	ILLEGAL ACC. PARAMETER (RIGID TAPPING OPTIMUM ACC/DEC)	The permissible acceleration parameter for rigid tapping optimum acceleration/deceleration contains an error. The cause is one of the following: <ol style="list-style-type: none"> <li>1) The ratio of the deceleration to the acceleration is less than 1/3.</li> <li>2) The time required to slow down to a speed of 0 exceeds the maximum.</li> <li>3) The maximum acceleration (parameters Nos. 11421 to 11424) is 0.</li> </ol>
DS1931	MACHINE PARAMETER INCORRECT	One of parameters Nos. 19665 to 19667 and Nos.19680 to 19744 used to configure the machine contains an error.
DS1932	DI.THML SIGNAL ON	One of the parameters used to configure the machine is rewritten while the tool direction thermal displacement compensation function is enabled.
DS1933	NEED REF RETURN(SYNC:MIX:OVL)	The relation between a machine coordinate of an axis in synchronization, composition, or superposition control, and the absolute, or relative coordinate was displaced. Perform the manual return to the reference position.

Number	Message	Description
DS5340	PARAMETER CHECK SUM ERROR	Because parameters have been modified, the parameter check sum and the standard check sum do not match. Restore the original parameter state, or set a standard check sum again.
DS5387	CAN NOT START REFERENCE RETURN WITH MECHANICAL STOPPER SETTING	The slave axis is not within the in-position width, for example, when the distance between the mechanical stoppers for the master and slave axes is larger than the withdrawal distance specified in parameter No. 7181 or 7182 for the master axis. Adjust the position of the mechanical stoppers or the setting of parameter No. 7181 or 7182.
DS5550	AXIS IMMEDIATE STOP	The movement along an axis was stopped immediately by the axis immediate stop function.

### (12) Malfunction prevention function alarms (IE alarm)

Number	Message	Description
IE0001	+ OVERTRAVEL ( SOFT 1 )	The malfunction prevention function detected that stored stroke check 1 on the positive side was exceeded.
IE0002	- OVERTRAVEL ( SOFT 1 )	The malfunction prevention function detected that stored stroke check 1 on the negative side was exceeded.
IE0003	+ OVERTRAVEL ( SOFT 2 )	The malfunction prevention function detected that stored stroke check 2 on the positive side was exceeded.
IE0004	- OVERTRAVEL ( SOFT 2 )	The malfunction prevention function detected that stored stroke check 2 on the negative side was exceeded.
IE0005	+ OVERTRAVEL ( SOFT 3 )	The malfunction prevention function detected that stored stroke check 3 on the positive side was exceeded.
IE0006	- OVERTRAVEL ( SOFT 3 )	The malfunction prevention function detected that stored stroke check 3 on the negative side was exceeded.
IE0007	EXCESS MAXIMUM REV. DATA	The malfunction prevention function detected the command in which a value exceeding the maximum speed was specified.
IE0008	ILLEGAL ACC/DEC	The malfunction prevention function detected the acceleration/deceleration error.

## A.2 ALARM LIST (PMC)

### A.2.1 Messages That May Be Displayed on the PMC Alarm Screen

The following table lists the PMC alarm messages that may be displayed on the PMC alarm screen.

Message	Faulty location/corrective action	Contents
ER01 PROGRAM DATA ERROR	(1) Enter the sequence program again. (2) If this error recurs even after you have entered the sequence program again, the error may be due to a hardware fault. In that case, contact us.	The sequence program is invalid.
ER02 PROGRAM SIZE OVER	(1) Reduce the size of the sequence program. (2) Contact us, and specify a ladder step count option that allows you to set a larger program size.	The sequence program is too large. The sequence program is invalid.

Message	Faulty location/corrective action	Contents
ER03 PROGRAM SIZE ERROR(OPTION)	(1) Reduce the size of the sequence program. (2) Contact us, and specify a ladder step count option that allows you to set a larger program size.	The sequence program exceeds the size specified by the ladder step count option.
ER04 PMC TYPE UNMATCH	Change the sequence program so that it specifies the adequate PMC type, by using the programmer.	The PMC type specified in the sequence program does not match the type of the PMC actually in use.
ER08 OBJECT UNMATCH	Contact us.	An unsupported function is used in the sequence program.
ER09 PMC LABEL CHECK ERROR	(1) Turn on the power of the CNC again, by holding down the 'O' and 'Z' keys at the same time. (2) Replace the backup batteries.	The nonvolatile memory of the PMC system needs to be initialized in such cases as when you have changed the PMC model.
ER17 PROGRAM PARITY	(1) Enter the sequence program again. (2) If this error recurs even after you have entered the sequence program again, the error may be due to a hardware fault. In that case, contact us.	The parity of the sequence program is invalid.
ER18 PROGRAM DATA ERROR BY I/O	Enter the sequence program again.	Reading sequence program was interrupted.
ER19 LADDER DATA ERROR	Display the LADDER DIAGRAM EDITOR screen again, and terminate the editing operation by pressing the [EXIT] soft key.	The CNC screen was forcibly displayed by the relevant function key during the editing of a ladder program.
ER22 NO PROGRAM	Enter the sequence program again.	The sequence program is empty.
ER27 LADDER FUNC. PRM IS OUT OF RANGE	Correct the sequence program; change the parameter number specified in a functional instruction to a value that is within the allowable range.	An out-of-range parameter number is specified in the TMR, TMRB, TMRBF, CTR, CTRB, DIFU, or DIFD functional instruction.
ER33 I/O Link ERROR(CHn) (Note3)	Contact us; replace the faulty hardware.	The LSI for the I/O Link is faulty.
ER34 I/O Link ERROR(CHn Gxx) (Note1) (Note3)	(1) Check the cable connections to the devices of group xx. (2) Check whether the power of each I/O device has been turned on before the CNC. (3) Replace any device of group xx in which the PMC control module is embedded.	An I/O device communication error occurred on the slave side of group xx.
ER35 TOO MUCH OUTPUT DATA IN GROUP(CHn Gxx) (Note1) (Note3)	Reduce the output data count of group xx.	The output data count of I/O Link group xx exceeds the upper limit (33 bytes). Alternatively, the output data count of I/O Link <i>i</i> group xx exceeds the upper limit (65 bytes by default or 29 bytes for the safety I/O device). The superfluous data is regarded as invalid.

Message	Faulty location/corrective action	Contents
ER36 TOO MUCH INPUT DATA IN GROUP(CHn Gxx) (Note1) (Note3)	Reduce the input data count of group xx.	The input data count of I/O Link group xx exceeds the upper limit (33 bytes). Alternatively, the input data count of I/O Link <i>i</i> group xx exceeds the upper limit (65 bytes by default or 29 bytes for the safety I/O device). The superfluous data is regarded as invalid.
ER37 TOO MUCH SLOT IN BASE(CHn) (Note3)	Correct the slot number to a value of 10 or less.	The slot number for the I/O Link exceed the upper limit (10). The slot number larger than 11 is regarded as invalid.
ER38 MAX SETTING OUTPUT DATA OVER(CHn Gxx) (Note1) (Note3)	Reduce the total amount of output data of all groups to 128 bytes or less. For I/O Link <i>i</i> , reduce the total amount of output data of all groups to 256 bytes or less.	The I/O area for the I/O Link is insufficient. (The area allocated to the group xx and later on the output side is regarded as invalid.) Alternatively, for I/O Link <i>i</i> , the I/O area is insufficient when the high-speed mode is not selected for the transfer cycle.
ER39 MAX SETTING INPUT DATA OVER(CHn Gxx) (Note1) (Note3)	Reduce the total amount of input data of all groups to 128 bytes or less. For I/O Link <i>i</i> , reduce the total amount of output data of all groups to 256 bytes or less.	The I/O area for the I/O Link is insufficient. (The area allocated to the group xx and later on the input side is regarded as invalid.) Alternatively, for I/O Link <i>i</i> , the I/O area is insufficient when the high-speed mode is not selected for the transfer cycle.
ER43 PROGRAM DATA ERROR(PT/NT)	<1> Store sequence program which is compiled again after recompilations using FANUC LADDER-III. <2> If you see the same alarm again after <1>, contact us.	The sequence program is invalid.
ER45 NO OPTION(FUNCTION BLOCK)	Add a required function block option.	No function block option is specified.
ER46 MESSAGE DATA UPDATE ERROR. PLEASE TRUN OFF POWER AFTER SAVING DATA.	Save the corrected sequence program or message data for multi-language display to F-ROM. Moreover, turn the power off/on.	The message data in the sequence program or the message data for multi-language display cannot be updated. It is necessary to turn off/on the power. The ladder program cannot be executed when this alarm occurs.
ER47 ILLEGAL OVERRIDE FUNCTION SETTING (TOO MANY PMC PATHS)	The "override mode" of the forced I/O function is available for up to three paths simultaneously. Make the "override mode" of the forced I/O function for several PMC paths and restart the CNC.	The "override mode" of the forced I/O function is enabled for four or more PMC paths.
ER48 STEP SEQUENCE TIME OVER(xxH)	On the time monitoring setting screen, delete the setting that exceeded the set time.	The step sequence activation time exceeded the time set on the time monitoring screen.
ER50 PMC EXECUTION ORDER ERROR	Check CNC parameter Nos. 11900 to 11904.	The execution order setting of the multi-PMC function is invalid.

Message	Faulty location/corrective action	Contents
ER51 PMC EXECUTION PERCENTAGE ERROR	Check CNC parameter Nos. 11905 to 11909.	The execution percentage setting of the multi-PMC function is invalid.
ER52 I/O Link CHANNEL ASSIGNMENT ERROR (Note3)	Check CNC parameter Nos. 11910 to 11912 .	The I/O Link channel assignment to the PMC system is invalid.
ER54 NC-PMC I/F ASSIGNMENT ERROR	Check CNC parameters Nos. 11920 to 11929.	The interface assignment between NC and PMC is invalid.
ER55 LEVEL1 EXECUTION CYCLE ERROR	Check CNC parameter No. 11930.	The ladder level 1 execution cycle setting is invalid.
ER57 MULTI PATH PMC I/F ASSIGNMENT ERROR	Check CNC parameter No. 11932.	Assignment of PMC path interface is illegal.
ER58 PMC MEMORY TYPE SETTING ERROR	Check CNC parameter Nos. 11940 to 11942.	Setting of the PMC memory type is illegal.
ER60 I/O Link <i>i</i> ERROR(CHn) (Note3)	Contact us and replace the hardware.	The LSI for I/O Link <i>i</i> is faulty.
ER61 I/O Link <i>i</i> ERROR(CHn Gxx) (Note1) (Note3)	(1) Check the cable connections to the devices in group xx. (2) Check whether the power to each I/O device has been turned on before the CNC. (3) Replace any device in group xx in which the PMC control module is embedded.	An I/O device communication error occurred on the slave side of group xx.
ER62 I/O Link <i>i</i> DCS ERROR (Note3)	Contact us and replace the hardware.	The LSI for the I/O Link <i>i</i> DCS is faulty.
ER63 I/O Link CHANNEL SETTING ERROR (Note3)	(1) Change the communication mode to modify the channel configuration with fewer points. Use bit 0 or 1 of NC parameter No. 11933 to specify whether to use I/O Link or I/O Link <i>i</i> for communication with each channel.	The number of I/O points has exceeded 4096/4096. For the I/O Link, the points are 1024/1024 per channel. For I/O Link <i>i</i> , they are 2048/2048 per channel.
ER64 I/O Link <i>i</i> TOO MANY CONNECTED GROUPS(CHn) (Note3)	Reduce the number of connected I/O devices to 24 or less.	In CHn, 25 or more I/O devices are connected.
ER65 I/O Link <i>i</i> TOO MANY SLOTS(CHn) (Note3)	Reduce the number of connected I/O device modules to 256 or less.	In CHn, 257 or more slots of I/O device modules are connected.
ER66 I/O Link <i>i</i> PMC ADDRESS OVERLAPPED (PMCm X(Y)nnnn) (Note3)	Enter the PMC address or size again so that any address is not used by multiple PMCs that share PMC memory.	I/O Link <i>i</i> assignment data is allocated at the PMCm X(Y)nnnn address and X(Y)nnnn address of the PMC for which the PMC memory share mode is set.
ER67 I/O Link <i>i</i> TOO MANY SAFETY I/O GROUPTS (Note3)	Reduce the group number of safety I/O.	The total group number of safety I/O in PMC paths exceed 4 or the total group number of safety I/O in DSCPMC exceed 4 for I/O Link <i>i</i> .
ER68 I/O Link <i>i</i> TOO MANY ASSIGNMENTS IN HIGH SPEED MODE (CHn,Gyy) (Note1) (Note3)	When a group in the high-speed transfer cycle mode is connected to I/O Link <i>i</i> , correct assignment so that the assignment for each group is performed within the quartered transfer timing with referencing the PMC programming manual (B-64513EN).	In CHn, assignment could not be made to group yy and following because the transfer capacity limit was exceeded in transfer timing assignment processing when the high-speed mode of I/O Link <i>i</i> is used.
ER69 I/O Link <i>i</i> ASSIGNMENT ADDRESS INVALID(CHx Gyy) (Note2) (Note3)	Modify I/O Link <i>i</i> assignment data.	I/O Link <i>i</i> assignment data for group yy in CHx contains a nonexistent PMC path address.

Message	Faulty location/corrective action	Contents
ER70 PMC ADDRESS BLOCK OVERLAPPED BETWEEN I/O Link AND I/O Link <i>i</i> (PMCm X(Y)nnnn) (Note3)	<ol style="list-style-type: none"> <li>(1) Delete the relevant I/O Link <i>i</i> assignment or change the assignment address.</li> <li>(2) Change the PMC address block of the relevant I/O Link channel. (Machine signal interface setting)</li> <li>(3) Check the I/O Link communication mode. (Bit 0 or 1 of NC parameter No. 11933)</li> <li>(4) Check the setting of the I/O Link <i>i</i> assignment selection function.</li> </ol>	The I/O Link and I/O Link <i>i</i> are assigned to the same PMC address block.
ER71 I/O Link <i>i</i> STATUS ALARM LENGTH OVER IN GROUP(CHn Gxx) (Note1) (Note3)	Modify the I/O device configuration so that the total length of status alarm data does not exceed 64 bytes.	The total length of status alarm data for I/O device modules connected to group xx of CHn exceeds the limit (64 bytes).
ER89 EDITING I/O CONFIGURATION DATA IS NOT COMPLETED	Complete the editing of I/O configuration data.	I/O configuration data is invalid because it is being edited.
ER90 TOO LARGE I/O CONFIGURATION DATA (Note3)	Reduce the size of the I/O configuration file.	I/O configuration data is larger than the save area.
ER91 I/O CONFIGURATION DATA PARITY (Note3)	<ol style="list-style-type: none"> <li>(1) Enter the I/O configuration file again.</li> <li>(2) If this error still occurs after reentry, a hardware failure may occur. Contact us.</li> </ol>	The parity of I/O configuration data is invalid.
ER92 I/O CONFIGURATION DATA ERROR BY I/O	Enter the I/O configuration file again.	Reading the I/O configuration file was interrupted.
ER93 UNSUPPORTED I/O CONFIGURATION DATA (Note3)	Modify the type of I/O configuration data and enter the data again.	I/O configuration data is of an unrecognizable type.
ER94 I/O CONFIGURATION DATA ERROR (Note3)	Compile the I/O configuration data using FL-III again and enter it again.	A data structure error was found in I/O configuration data.

Message	Faulty location/corrective action	Contents
ER95 IO DEVICE MISMATCH(CHn) (Note3)	<p>When this alarm is issued with a machine which has operated normally, possible causes are:</p> <ol style="list-style-type: none"> <li>(1) The communication cable is broken or a connection failure occurs in the cable.</li> <li>(2) The power to an I/O device is off or is turned on too late.</li> <li>(3) A failure occurs in an I/O device.</li> <li>(4) When the power to the CNC is turned off, then on again, the power to an I/O device is kept on. When turning the power to the CNC off, then on again, be sure to turn the power to all I/O devices off, then on.</li> </ol> <p>When this alarm is issued during debugging of a sequence program, there are the following possible causes in addition to the above:</p> <ol style="list-style-type: none"> <li>(5) The connected I/O device configuration (type, sequence, or number of units) is invalid.</li> <li>(6) An invalid I/O device configuration is registered.</li> </ol> <p>When this alarm is issued, any inconsistent I/O device can be checked in the "I/O Device Monitor screen".</p>	<p>This alarm is issued when the I/O devices actually connected to the CNC is inconsistent with the I/O device configuration registered in the I/O device connection diagnosis screen. All I/O devices connected to the channel for which this alarm was issued are not linked. The ladder program is run even when this alarm is issued.</p>
ER96 IO Link MAX GROUP OVER(CHn) (Note 3)	<ol style="list-style-type: none"> <li>(1) Check the PMC paths and addresses of blocks 1 and 2 in channel n in the CONFIG PARAM screen.</li> <li>(2) Check the total number of groups in blocks 1 and 2 in I/O module allocation setting.</li> <li>(3) Check the parameter setting for the Selectable I/O Link assignment function.</li> </ol>	<p>When 2-path allocation for the I/O Link channel is used, the total number of groups in blocks 1 and 2 exceeds 16. All I/O devices connected to the channel for which this alarm was issued are not linked. The ladder program is run even when this alarm is issued.</p>



Message	Faulty location/corrective action	Contents
ER97 IO Link FAILURE(CHn Gyy) (Note1) (Note3)	<p>When this alarm is issued with a machine which has operated normally, possible causes are:</p> <ol style="list-style-type: none"> <li>(1) The communication cable from group yy-1 to group yy is broken or a connection failure occurs in the cable.</li> <li>(2) The power to an I/O device in group yy or following is off or is turned on too late.</li> <li>(3) A failure occurs in an I/O device in group yy or yy-1.</li> <li>(4) When the power to the CNC is turned off, then on again, the power to an I/O device is kept on. When turning the power to the CNC off, then on again, be sure to turn the power to all I/O devices off, then on.</li> </ol> <p>When this alarm is issued during debugging of a sequence program, there are the following possible causes in addition to the above:</p> <ol style="list-style-type: none"> <li>(5) The number of groups of connected I/O devices is invalid.</li> <li>(6) The I/O module allocation setting is invalid.</li> <li>(7) The parameter setting for the I/O Link assignment data selection function is invalid.</li> <li>(8) The machine signal interface is invalid.</li> </ol> <p>When this alarm is issued, details can be checked in the "I/O Device Monitor screen".</p>	<p>This alarm is generated if the number of I/O units is insufficient. This alarm is generated if the number of I/O units, set with the I/O module allocation and I/O link allocation selection functions differs from the number of I/O units actually connected to the CNC. All I/O devices connected to the channel for which this alarm was issued are not linked.</p> <p>The ladder program runs regardless of the occurrence of this alarm.</p>
WN02 OPERATE PANEL ADDRESS ERROR	Correct the Series 0 operator's panel address that is set in the PMC system parameter.	The Series 0 operator's panel address that is set in the PMC system parameter is invalid.
WN03 ABORT NC-WINDOW/EXIN	Modify the ladder program and turn on the power of the CNC again. Refer to subsection "4.15" of PMC programming manual (B-64513EN) for details.	The ladder program was stopped while communication was in progress between CNC and PMC. This alarm may cause the WINDR, WINDW, EXIN, and DISPB functional instructions to malfunction.
WN07 LADDER SP ERROR(STACK)	Correct the sequence program so that the subprogram has eight or fewer levels of nesting.	There are too many levels of nesting (levels more than 8) for the CALL or CALLU functional instruction to call the subprogram.

Message	Faulty location/corrective action	Contents
WN09 SEQUENCE PROGRAM IS NOT WRITTEN TO FLASH ROM	If you want to use the current sequence program next time you power on the system, write the sequence program to flash ROM. If you have made any unwanted change to the sequence program by mistake, read the original sequence program from flash ROM.	You have changed the sequence program using the LADDER DIAGRAM EDITOR screen or DATA I/O screen, but you have not yet written the changed sequence program to flash ROM. If you shut down the system without writing the changed sequence program to flash ROM, the changes you have made will be nowhere next time you turn on the power.
WN10 NO OPTION(STEP SEQUENCE)	(1) Add the step sequence option. (2) Arrange so that the step sequence subprogram will not be called.	No step sequence option was found when the system attempted to execute a step sequence.
WN11 INCOMPATIBLE FUNCTION	Re-compile the program, using FANUC LADDER-III or a ladder editing package.	There is a functional instruction that does not conform to this PMC.
WN57 OVERRIDE FUNCTION IS ACTIVE	The Override function is for debugging only. So, please disable the function when shipping the machine.	The Override function is activated.
WN58 UNSUPPORTED FUNCTION	Modify the program, using the built-in ladder editing function.	There is an unsupported functional instruction. This instruction was not processed.
WN59 MESSAGE FILE SYMBOL UNDEFINED	Correct the error in the message file for multi-language display.	In the message file for multi-language display, a symbol that does not exist in the ladder is defined.
WN60 MESSAGE FILE SYMBOL INVALID	Correct the error in the message file for multi-language display.	In the message file for multi-language display, a symbol other than an A address is defined.
WN61 MESSAGE FILE ADDRESS DUPLICATE	Correct the error in the message file for multi-language display.	An A address is defined more than once in a symbol and an address or in symbols.
WN62 MESSAGE FILE NUMBER ERROR	Correct the error in the message file for multi-language display.	For the same A address, the message number in the ladder differs from that in the message file for multi-language display.
WN63 MESSAGE FILE IS NOT WRITTEN TO FLASH ROM	If you want to use the current message file for multi-language display the next time you turn on the power, write the message file to the flash ROM.	On the data I/O screen, the message data for multi-language display was changed, but the changed message data for multi-language display is not yet written to the flash ROM. The changed message data for multi-language display will be lost the next time the power is turned on.
WN64 MESSAGE FILE SIZE OVER	(1) Reduce the message file for multi-language display. (2) Contact us, and specify an option of a larger size.	The message file for multi-language display is larger than the program storage area. The message file for multi-language display is illegal.
WN65 MESSAGE FILE MISMATCH	Contact us.	An unsupported function is used in the message file for multi-language display.

Message	Faulty location/corrective action	Contents
WN66 MESSAGE FILE PARITY	<p>(1) Re-enter the message file for multi-language display.</p> <p>(2) If this error recurs even after you have entered the sequence program again, the error may be due to a hardware fault. In that case, contact us.</p>	The parity of the message file for multi-language display is illegal.
WN67 MESSAGE FILE ERROR BY I/O	Re-enter the message file for multi-language display.	Reading the message file for multi-language display was interrupted.
WN68 I/O CONFIGURATION DATA IS NOT WRITTEN TO FLASH ROM	If you want to use changed I/O configuration data again next time you power on the system, write the I/O configuration data to flash ROM.	You have changed I/O configuration data using the I/O configuration data editing or DATA I/O screen, but you have not yet written the changed I/O configuration data to flash ROM. If you shut down the system without writing the changed I/O configuration data to flash ROM, the changes you have made will be nowhere next time you turn on the power.
WN69 I/O Link i DO ALARM (CHn Gxx Syy zz : PMCm Ybbb = **H) (Note1)	Check DO of the relevant device.	<p>The DO alarm (ex. a short circuit with the ground) occurs at "zz" bytes of slot "yy" of group "xx" in channel "n".</p> <p>Y "bbbb" of PMC path "m" is the address at which the alarm occurred. DCSPMC Y"bbbb" is the address for DCSPMC. Display of "PMC*Y****" is the case of occurrence of unassigned address.</p> <p>The "***H" shows some bits at which the alarm occurs by hexadecimal. (Ex. "PMC1Y115=28H" shows the alarm occurs at Y115.3 and Y115.5 in PMC1. "28H" means "00101000" in binary. )</p> <p>For the details of the alarm of I/O devices, refer to the "Connection manual (HARDWARE) (B-64483EN)".</p>
WN70 I/O Link i STATUS ALARM (CHn Gxx Syy zz = **H) (Note1)	Check the alarm information of applied I/O device.	<p>The status alarm except for the DO alarm occurs at "zz" bytes of slot "yy" of group "xx" in channel "n".</p> <p>The "***H" shows some bits at which the alarm occurs by hexadecimal.</p> <p>For the details of the alarm of I/O devices, refer to the "Connection manual (HARDWARE) (B-64483EN)".</p>

**NOTE**

- 1 The displayed group number in ER34, ER35, ER36, ER38, ER39, ER61, ER68, ER71, ER97, WN69 and WN70 is wiring number of I/O device.
- 2 The group number displayed in ER69 is the number of I/O Link *i* assignment data.
- 3 When some PMC alarms related to I/O Link and I/O Link *i* occur, all of I/O devices in all of channels do not be linked with the CNC.

**A.2.2 PMC System Alarm Messages****SYS\_ALM199 error messages (PMC general)**

Message	Faulty location / corrective action	Contents
PC004 CPU INVALID INSTRUCTION ----< ERROR POSITION >---- MAIN BOARD -----	This alarm may be due to a main board fault.	A CPU error occurred in the PMC system.
PC006 CPU INVALID SLOT INSTRUCTION ----< ERROR POSITION >---- MAIN BOARD -----		
PC009 CPU ADDRESS ERROR ----< ERROR POSITION >---- MAIN BOARD -----		
PC010 DMA ADDRESS ERROR ----< ERROR POSITION >---- MAIN BOARD -----		
PC012 CPU USER BREAK EXCEPTION ----< ERROR POSITION >---- MAIN BOARD -----		
PC030 RAM PARITY PC030 S-RAM PARITY ----< ERROR POSITION >---- MAIN BOARD -----		
PC060 BUS ERROR ----< ERROR POSITION >---- MAIN BOARD -----	A BUS error occurred in the PMC system.	
PC070 ILLEGAL LADDER SPE (PMCn) ----< ERROR POSITION >---- MAIN BOARD -----	A stack error occurred with the SPE functional instruction of the ladder program of n path.	
PC071 ILLEGAL LADDER FBE (PMCn) ----< ERROR POSITION >---- MAIN BOARD -----	A stack error occurred with the FBE instruction of the ladder program of path n. (Path n PMC)	
PC072 STACK OVERFLOW (TASK:xx) PC072 STACK OVERFLOW (INT:xx) ----< ERROR POSITION >---- MAIN BOARD -----	A stack error occurred (detected by the software).	

Message	Faulty location / corrective action	Contents
PC080 SYSTEM EMERGENCY -----< ERROR POSITION >----- MAIN BOARD -----	This alarm may be due to a main board fault.	System emergency state of the PMC LSI.
PC090 SYSTEM EMERGENCY (SOFTWARE) PC090 NON MASKABLE INTERRUPT (SOFTWARE) PC090 NON MASKABLE INTERRUPT (UNKNOWN) -----< ERROR POSITION >----- MAIN BOARD -----		CPU error (unexpected NMI) occurs in PMC control software.
PC093 UNEXPECTED INTERRUPT (xx) -----< ERROR POSITION >----- MAIN BOARD -----		
PC094 UNEXPECTED TRAP EXCEPTION (xx) -----< ERROR POSITION >----- MAIN BOARD -----		A trap exception of unknown cause occurred with the PMC management software.
PC095 MESSAGE CRC ERROR (PMCn) -----< ERROR POSITION >----- MAIN BOARD -----		A RAM check error occurred.
PC096 LADDER CODE ERROR (___) -----< ERROR POSITION >----- MAIN BOARD -----		
PC097 LADDER CRC ERROR (PMCn) -----< ERROR POSITION >----- MAIN BOARD -----		
PC098 PMC SOFTWARE CRC ERROR PC098 PMC SOFTWARE ECC ERROR (____:_) -----< ERROR POSITION >----- MAIN BOARD -----		
PC501 CNC/PMC INTERFACE ERROR (PATHx) -----< ERROR POSITION >----- MAIN BOARD -----		The read or write operation between CNC and PMC failed.

**SYS\_ALM197 error messages (PMC general)**

Message	Faulty location / corrective action	Contents
PC070 ILLEGAL LADDER SPE (DCSPMC) ----< ERROR POSITION >---- CPU CARD -----	This alarm may be due to a CPU card fault.	A stack error occurred with the SPE functional instruction of the ladder program of DCSPMC.
PC071 ILLEGAL LADDER FBE (DCSPMC) ----< ERROR POSITION >---- CPU CARD -----		A stack error occurred with the FBE instruction of the ladder program of DCSPMC
PC095 MESSAGE CRC ERROR (DCSPMC) ----< ERROR POSITION >---- CPU CARD -----		A RAM check error occurred.
PC097 LADDER CRC ERROR (DCSPMC) ----< ERROR POSITION >---- CPU CARD -----		

**SYS\_ALM196 error messages (PMC watchdog)**

Message	Faulty location / corrective action	Contents
PC073 WATCH-DOG ALARM(CNC<->PMC) ----< ERROR POSITION >---- MAIN BOARD -----	This alarm may be due to a main board fault.	The PMC CPU is not running.

**SYS\_ALM195 error messages (related to the I/O Link)**

Message	Faulty location / corrective action	Contents
PC050 I/O LINK ER1 CHn:GRxx:yy COMMUNICATION ALARM AT CHn : GROUP xx -< ERROR POSITION>- CHn / GROUPxx -----	<ol style="list-style-type: none"> <li>(1) Check the I/O device of group "xx" in channel "n": <ul style="list-style-type: none"> <li>- Instantaneous power failure</li> <li>- Unstable power line</li> </ul> </li> <li>(2) Check the I/O Link cable between JD1B of group "xx" and JD1A of group "xx-1" <ul style="list-style-type: none"> <li>- faulty wiring</li> <li>- incomplete contact</li> </ul> </li> <li>(3) The I/O Link device of group "xx" in channel "n" is faulty.</li> </ol>	<p>An I/O Link communication error occurred.</p> <p>"n" is a channel number (1 to 3). "xx" is a group number (0 to 15). "yy" is a internal error code.</p> <p>This error occurs when the communication with the device of group "xx" in channel "n" is stopped.</p> <p>The causes are as follows:</p> <ul style="list-style-type: none"> <li>- Instantaneous power failure, unstable voltage or unstable power line of the device</li> <li>- Faulty wiring or incomplete contact of communication cable</li> <li>- Faulty device</li> </ul> <p>Please note that It may not show an accurate group number with some conditions of the problem.</p>

Message	Faulty location / corrective action	Contents
<p>PC051 I/O LINK ER2 CHn:yy:xx:ww:vv                      COMMUNICATION ALARM AT CHn                      -----&lt; ERROR POSITION &gt;-----                      CHn                      -----</p>	<ol style="list-style-type: none"> <li>(1) When you use an I/O Unit-Model A, no base extension unit is connected corresponding to an I/O assignment data. Check connection of I/O devices and I/O assignment data.</li> <li>(2) When you use Power Mate as I/O Link slave device and/or Servo Motor Beta series I/O Link option, some system alarm occurs in such devices.</li> <li>(3) A Communication may be influenced by noise. Check the ground wire and the shield of the communication cables.</li> <li>(4) The output of the I/O Link devices is short-circuited.</li> <li>(5) The power of the I/O Link master and/or slave devices is faulty.                             <ul style="list-style-type: none"> <li>- Instantaneous power failure</li> <li>- Unstable power line</li> </ul> </li> <li>(6) Incomplete contact of the communication cable</li> <li>(7) Faulty wiring of the communication cable</li> <li>(8) Check the grounding of the shield wire of the earth terminal or the communication cable of I/O devices.</li> <li>(9) I/O Link devices are faulty.</li> <li>(10) I/O Link master is faulty.                              n=1,2: main board                              n=3: CPU card</li> </ol>	<p>An I/O Link communication error occurred.                      "n" is a channel number (1 to 3).                      "yy", "xx", "ww" and "vv" are internal error code.                      There are various causes as for this error.</p>

**SYS\_ALM194 error messages (related to the I/O Link i)**

Message	Faulty location / corrective action	Contents
<p>PC052 I/O LINK I                      PMC LSI RAM PARITY ERROR                      -----&lt; ERROR POSITION &gt;-----                      MAIN BORAD                      -----</p>	<p>Change the main board.</p>	<p>A RAM parity error occurred in PMC LSI on the main board.</p>
<p>PC053 I/O LINK I                      SLAVE LSI RAM PARITY ERROR                      -----&lt; ERROR POSITION &gt;-----                      CHn / UNITYy(GROUPx) : "unit name"                      (Note 1)                      -----</p>	<p>Change the I/O device of the unit.</p>	<p>A RAM parity error occurred in "y"th unit (group "x") of channel "n".</p>

Message	Faulty location / corrective action	Contents
PC054 I/O LINK I ABNORMAL POWER SUPPLY -----< ERROR POSITION >----- CHn / UNITYy(GROUPx) : "unit name" (Note 1) -----	Check the power supply of the I/O unit.	A power disconnection alarm occurred in the "y"th unit (group "x") of channel "n".
PC055 I/O LINK I I/O LINK I SENDING DATA FAILURE -----< ERROR POSITION >----- CHn / CNC <-> UNIT1(GROUP0) CNC : MAIN BOARD UNIT1 : "unit name" (Note 1) -----	Check whether there is a possibility that noise is inserted between the CNC and 1st unit. Check the ground status of the slave device and the contact of the connection cable.	A communication error occurred between the CNC and 1st unit (group 0) of channel "n".
PC055 I/O LINK I I/O LINK I SENDING DATA FAILURE -----< ERROR POSITION >----- CHn / UNITYy-1(GROUPx-1) <-> UNITYy(GROUPn) UNITYy -1 : "unit name" (Note 1) UNITYy : "unit name" (Note 1) -----	Check whether there is any noise is inserted between the "y-1"th unit (group "x-1") and "y"th unit (group "x"). Check the ground status of the slave device and the contact of the the connection cable.	A communication error occurred between the "y-1"th unit (group "x-1") and the "y"th unit (group "x") of channel "n".
PC056 I/O LINK I I/O LINK I DISCONNECTION -----< ERROR POSITION >----- CHn / CNC <-> UNIT1(GROUP0) CNC : MAIN BOARD UNITYy : "unit name" (Note 1) -----	Check whether there is disconnection or incomplete contact for the cable between the CNC and 1st unit (group 0).	Connection error occurred between the CNC and 1st unit (group 0) of channel "n".
PC056 I/O LINK I I/O LINK I DISCONNECTION -----< ERROR POSITION >----- CHn / UNITYy-1(GROUPx-1)<-> UNITYy(GROUPn) UNITYy -1 : "unit name" (Note 1) UNITYy : "unit name" (Note 1) -----	Check whether there is disconnection or incomplete contact of the cable between the "y-1"th unit (group "x-1") and "y"th unit (group "x").	Connection error occurred between the "y-1"th unit (group "x-1") and "y"th unit (group "x") of channel "n".
PC057 I/O LINK I SAFETY I/O ALARM -----< ERROR POSITION >----- UNITYy : "unit name" (Note 1) -----	Change the I/O device of the unit. If the error still occurs, change the main board.	A hardware failure of the safety I/O occurred between the CNC and the "y"th unit.
PC058 I/O LINK I SLAVE LSI EXTERNAL ALARM -----< ERROR POSITION >----- CHn / UNITYy(GROUPx) : "unit name" (Note 1) -----	Change the I/O device of the unit.	A hardware failure occurred on the "y"th unit (group "x") of channel "n".



**NOTE**

- 1 When the unit name of the connected I/O device is unknown, its hardware ID is displayed.
- 2 For some I/O devices, one unit such as a safety I/O unit may consist of two groups. If a connection failure occurs between groups containing units of the same type, PC058 instead of PC056 indicating a connection failure occurs as a unit failure.

### A.2.3 Operation Errors

#### Error messages that may be displayed on the PMC LADDER DIAGRAM VIEWER screen

Message	Faulty location/corrective action	Contents
INPUT INVALID	Input a valid address or numeric value.	The input address or numeric value is invalid.
PROGRAM IS PROTECTED BY PASSWORD	Enter the password.	The screen cannot be displayed because the program is protected by the password.
ILLEGAL SUBPROGRAM NAME	Input a existent subprogram number or symbol.	A nonexistent subprogram number or symbol is specified.
SYMBOL UNDEFINED	Input a defined symbol or bit address.	An undefined symbol character string is specified.
THE NET IS NOT FOUND		The specified net is not found.
THE ADDRESS IS NOT FOUND		The specified address is not found.
THE FUNCTIONAL INSTRUCTION IS NOT FOUND		The specified functional instruction is not found.
WRITE COIL NEEDS BIT ADDRESS	Specify a bit address for the write coil search.	You entered a byte address when specifying an address used for the write coil search.
SOME NETS ARE DISCARDED	The system cannot pick up all the nets. Choose the nets to pick up, by using the LADDER DIAGRAM VIEWER display screen, and then perform the net pickup operation manually.	The system failed to pick up all the nets because there were 128 nets or more to be picked up.
PROGRAM IS BEING MODIFIED	Disconnect the online communication with FANUC LADDER-III. Stop other applications from accessing the ladder data.	The ladder data cannot be displayed because online communication with FANUC LADDER-III is in progress or another application is accessing the ladder data.
THIS FUNCTION IS PROTECTED	Cancel the protection by the programmer protection function or 8-level protection function.	This function is protected by the programmer protection function or 8-level protection function.
CANNOT EDIT FUNCTION BLOCK	Edit the program using FANUC LADDER-III.	An attempt was made to edit an FB main program.

#### Error messages that may be displayed on the PMC LADDER DIAGRAM EDITOR screen

Message	Faulty location/corrective action	Contents
THIS NET IS PROTECTED		When you are editing data on a per-subprogram basis, you cannot edit the subprogram frame nets (END1, END2, END3, SP, and SPE).

Message	Faulty location/corrective action	Contents
TOO LARGE DATA TO COPY	Reduce the range of data to copy. Perform the copy operation several times, copying a smaller range of data at a time.	The selected range of data exceeds the size of the copy buffer.
TOO LARGE DATA TO PASTE	Reduce the size of data to paste.	An attempt was made to paste data whose size exceeded the free space of the sequence program.
BIT ADDRESS IS REQUIRED	Make sure that the address types match for the alteration operation.	An attempt was made to alter a bit address to a byte address.
BYTE ADDRESS IS REQUIRED	Make sure that the address types match for the alteration operation.	An attempt was made to alter a byte address to a bit address.
ILLEGAL PMC ADDRESS	Check the address to be input, and then enter it correctly.	<ul style="list-style-type: none"> <li>• A character string was entered that was unacceptable as a PMC address.</li> <li>• A wildcard (*) was specified in an inappropriate manner.</li> <li>• Either "OLD ADDRESS" or "NEW ADDRESS" was not entered.</li> </ul>
THE ADDRESS IS READ-ONLY	Enter a write-permitted address.	<ul style="list-style-type: none"> <li>• An attempt was made to alter a write coil address to a write-prohibited bit address.</li> <li>• An attempt was made to alter an address set in an output parameter of a functional instruction to a write-prohibited bit address.</li> </ul>
THE ADDRESS TYPE ARE MISMATCHED	Check the types of the address in "OLD ADDRESS" and "NEW ADDRESS" and, if necessary, enter the correct address or addresses.	The type of the addresses for "OLD ADDRESS" does not match that in "NEW ADDRESS".
***** DOSE NOT HAVE SYMBOL	Define symbol data in "OLD ADDRESS".	No symbol data is defined in "OLD ADDRESS".
***** ALREADY HAS SYMBOL	Make sure that the address types match for the alteration operation.	Symbol data is already defined in "NEW ADDRESS".
CANNOT CUT FUNCTION BLOCK	Use FANUC LADDER-III to edit function block. Cut nets which do not include any function block.	An attempt was made to cut a net containing a function block.
CANNOT COPY FUNCTION BLOCK	Use FANUC LADDER-III to edit function block. Copy nets which do not include any function block.	An attempt was made to copy a net containing a function block.
CANNOT EDIT FUNCTION BLOCK	Edit the program using FANUC LADDER-III.	An attempt was made to edit an FB main program.
CANNOT INPUT AT THIS SCREEN	Set the address in the NET EDITOR screen.	An attempt was made to set an address to the output section in a function block which is omitted.
CANNOT EDIT INPUT/OUTPUT PARAM ADDRESS		The input section of the input/output parameter in a function block cannot be edited.
NO CONSTANT TO PARAMETER OF PLURAL TYPE		No constant can be set when multiple input parameters are specified for a function block.

## Error messages that may be displayed on the PMC LADDER DIAGRAM EDITOR screen (when updating)

Message	Faulty location/corrective action	Contents
OVERLAPPED COM	If COME is missing, add it in proper position. If the COM is unnecessary, remove it.	There is no COME that corresponds to this COM.
END IN COM END1 IN COM END2 IN COM	If COME is missing, add it in proper position. If COM is unnecessary, remove it.	END,END1,END2, or END3 is found between COM and COME.
JMPE IN COM	JMPE and corresponding JMP must have same COM/COME status. Review JMP range and COM range, to adjust not to overlap with each other: it is possible that one range includes the other completely.	JMPE is found between COM and COME, and JMP and corresponding JMPE have different COM/COME status.
SP/SPE IN COM	If COME is missing, add it in proper position. If the COM is unnecessary, remove it.	SP or SPE is found between COM and COME.
COME WITHOUT COM	If COM is missing, add it in proper position. If the COME is unnecessary, remove it.	There is no COM that corresponds to this COME.
DUPLICATE CTR NUMBER (WARNING)	If some of them are unnecessary, remove them. If all of them are necessary, assign other number to parameter of them to make them unique. (If two or more instructions with same parameter number will never be active simultaneously at one time, the Ladder program has a possibility to work correctly, however, it is recommended from safety and maintenance points of view, that all these instructions should have different parameter number with each other.)	Plural CTRs have the same number as their parameter. (This is warning.)
ILLEGAL CTR NUMBER	If unnecessary, remove it. Assign correct number not to exceed the maximum number defined by each PMC model.	CTR has parameter number that is out of range.
DUPLICATE DIFU/DIFD NUMBER (WARNING)	If some of them are unnecessary, remove them. If all of them are necessary, assign other number to parameter of them to make them unique. (If two or more instructions with same parameter number will never be active simultaneously at one time, the Ladder program has a possibility to work correctly, however, it is recommended from safety and maintenance points of view, that all these instructions should have different parameter number with each other.)	Plural DIFUs or DIFDs have the same number as their parameter. (This is warning.)
ILLEGAL DIFU/DIFD NUMBER	If unnecessary, remove it. Assign correct number not to exceed the maximum number defined by each PMC model.	DIFU or DIFD has parameter number that is out of range.

Message	Faulty location/corrective action	Contents
NO END NO END1 NO END2 NO END3	Add END, END1, END2 or END3 in proper position.	END, END1, END2 or END3 is not found.
DUPLICATE END1 DUPLICATE END2 DUPLICATE END3	Remove extra END1, END2 or END3.	Multiple END1, END2 or END3 are found.
GARBAGE AFTER END GARBAGE AFTER END2 GARBAGE AFTER END3	Remove unnecessary nets, and move necessary nets to proper position so that they will be executed.	There are some nets after END, END2 or END3, which will not be executed.
OVERLAPPED JMP	If JMPE is missing, add it in proper position. If the JMP is unnecessary, remove it.	There is no JMPE that corresponds to this JMP.
JMP/JMPE TO BAD COM LEVEL	JMP and corresponding JMPE must have same COM/COME status. Review JMP range and COM range, to adjust not to overlap with each other: it is possible that one range includes the other completely.	JMP and corresponding JMPE have different COM/COME status.
COME IN JMP	COME and corresponding COM must have same JMP/JMPE status. Review COM range and JMP range, to adjust not to overlap with each other: it is possible that one range includes the other completely.	COME is found between JMP and JMPE, and COM and corresponding COME have different JMP/JMPE status.
END IN JMP END1 IN JMP END2 IN JMP END3 IN JMP	If JMPE is missing, add it in proper position. If JMP is unnecessary, remove it.	END,END1,END2, or END3 is found between JMP and JMPE.
SP/SPE IN JMP	If JMPE is missing, add it in proper position. If the JMP is unnecessary, remove it.	SP or SPE is found between JMP and JMPE.
JMPB OVER COM BORDER	JMPB and its destination must have same COM/COME status. Review range of JMPB and COM range, to adjust not to overlap with each other: it is possible that one range includes the other completely.	JMPB and its destination differ in COM/COME status.
JMPB OVER LEVEL	JMPB can only jump to the same program level, or within a subprogram. If the JMPB is unnecessary, remove it. If LBL for the JMPB is missing, add it in proper position. If it should be JMPC, correct it.	JMPB jumps to different program level.
LBL FOR JMPB NOT FOUND	If JMPB is unnecessary, remove it. If LBL is missing, add it in proper position.	Can not find proper LBL for JMPB.
JMPC IN BAD LEVEL	JMPC is used to jump from a subprogram to level 2. If the JMPC is unnecessary, remove it. If it should be JMPB or JMP, correct it.	JMPC is used in other than subprogram.
LBL FOR JMPC NOT FOUND	If JMPC is unnecessary, remove it. If LBL is missing, add it in proper position: JMPC jumps into level 2.	Can not find proper LBL for JMPC.

Message	Faulty location/corrective action	Contents
LBL FOR JMPC IN BAD LEVEL	JMPC is used to jump from a subprogram to level 2. If the JMPC is unnecessary, remove it. If another LBL of same L-address that the JMPC is intended to jump exists in the subprogram, assign different L-address to these two LBLs. If it should be JMPB or JMP, correct it.	Destination of JMPC is not level 2.
JMPC INTO COM	LBL for JMPC must be located out of any COM and COME pair. If the JMPC is unnecessary, remove it. If the LBL is located wrong, move it to correct position. If the L-address of JMPC is wrong, correct it.	JMPC jumps to LBL between COM and COME.
JMPE WITHOUT JMP	If JMP is missing, add it in proper position. If the JMPE is unnecessary, remove it.	There is no JMP that corresponds to this JMPE.
JMPE NOT FOUND AFTER JMP	If JMPE is missing, add it in proper position. If the JMP is unnecessary, remove it.	There is no JMPE that corresponds to this JMP.
TOO MANY LBL	Remove unnecessary LBLs. If this error still occurs, adjust the construction of program to use less LBLs.	There are too many LBLs.
DUPLICATE LBL	If some of these LBLs are unnecessary, remove them. If all of these LBLs is necessary, assign other L-addresses to them to make all LBLs unique.	Same L-address is used in plural LBLs.
OVERLAPPED SP	If SPE is missing, add it in proper position. If the SP is unnecessary, remove it.	There is no SPE that corresponds to this SP.
SPE WITHOUT SP	If SP is missing, add it in proper position. If the SPE is unnecessary, remove it.	There is no SP that corresponds to this SPE.
SPE NOT FOUND AFTER SP	If SPE is missing, add it in proper position. If the SP is unnecessary, remove it.	There is no SPE that corresponds to this SP.
END IN SP	If SPE is missing, add it in proper position. If END is in wrong place, move it to proper position.	END is found between SP and SPE.
DUPLICATE P ADDRESS	If some of these SPs are unnecessary, remove them. If all of these SPs is necessary, assign other P-addresses to them to make all SPs unique.	Same P-address is used in plural SPs.
DUPLICATE TMRB/TMRBF NUMBER (WARNING)	If some of them are unnecessary, remove them. If all of them are necessary, assign other number to parameter of them to make them unique. (If two or more instructions with same parameter number will never be active simultaneously at one time, the Ladder program has a possibility to work correctly, however, it is recommended from safety and maintenance points of view, that all these instructions should have different parameter number with each other.)	Plural TMRBs/TMRBFs have the same number as their parameter. (This is warning.)

Message	Faulty location/corrective action	Contents
ILLEGAL TMRB/TMRBF NUMBER	If unnecessary, remove it. Assign correct number not to exceed the maximum number defined by each PMC model.	TMRB/TMRBF has parameter number that is out of range.
DUPLICATE TMR NUMBER (WARNING)	If some of them are unnecessary, remove them. If all of them are necessary, assign other number to parameter of them to make them unique. (If two or more instructions with same parameter number will never be active simultaneously at one time, the Ladder program has a possibility to work correctly, however, it is recommended from safety and maintenance points of view, that all these instructions should have different parameter number with each other.)	Plural TMRs have the same number as their parameter. (This is warning.)
ILLEGAL TMR NUMBER	If unnecessary, remove it. Assign correct number not to exceed the maximum number defined by each PMC model.	TMR has parameter number that is out of range.
NO SUCH SUBPROGRAM	If it calls wrong subprogram, correct it. If the subprogram is missing, create it.	Subprogram that is called by CALL/CALLU is not found.
UNAVAILABLE INSTRUCTION	Confirm that this ladder program is correct one. If this program is correct one, all these unsupported instructions have to be removed.	Unsupported instruction for this PMC model is found.
SP IN BAD LEVEL	SP can be used at top of a subprogram. Correct it so that no SP exists in other place.	SP is found in wrong place.
LADDER PROGRAM IS BROKEN	This ladder program must be all cleared once, and remake ladder program.	Ladder program may be broken by some reason.
NO WRITE COIL	Add proper write coil.	Write coil is necessary, but is not found.
CALL/CALLU IN BAD LEVEL	CALL/CALLU must be used in Level 2 or in subprograms. Do not use any other places.	CALL/CALLU is used in wrong place.
SP IN LEVEL3	If END3 is located wrong, move it to correct position. If the SP is unnecessary, remove it.	SP is found in level 3.
CS/CM/CE IN COM	If COME is missing, add it in proper position. If the COM is unnecessary, remove it.	CS, CM, or CE is found between COM and COME.
CS/CM/CE IN BAD LEVEL	CS/CM/CE must be used in Level 2 or in subprograms. Do not use any other places.	CS/CM/CE is used in wrong place.
CM/CE WITHOUT CS	If CS is missing, add it in proper position. If the CM/CE is unnecessary, remove it.	There is no CS that corresponds to this CM/CE.
INSTRUCTION EXCEPT CM IN CS	If CE is missing, add it in proper position. If the CS/CE is unnecessary, remove it.	After an CS instruction, there was an instruction other than CM before an CE instruction came.
OVERLAPPED CS	If CS is missing, add it in proper position. If the CM/CE is unnecessary, remove it.	There is no CE that corresponds to this CS.
FB BODY PROGRAM IS BROKEN	Delete the entire ladder program and create it again.	The FB main program is corrupted.

### Error messages that may be displayed on the PMC NET EDITOR screen

Message	Faulty location/corrective action	Contents
ILLEGAL FUNCTIONAL INSTRUCTION NAME	Specify the name of an available functional instruction.	The entered name of functional instruction is invalid.
TOO MANY FUNCTIONAL INSTRUCTIONS IN ONE NET	Only one functional instruction is allowed to constitute a net. If necessary, divide the net into plural nets.	Too many functional instructions are in one net.
TOO LARGE NET	Divide the net into plural nets so that step number in a net may become small.	Net is too large. When a net is converted into the object, the net exceeds 256 steps.
NO INPUT FOR OPERATION	Coil without input, or coil connected to output of functional instruction that has no output, causes this error. If coil is not necessary, remove it. If necessary, connect it to meaningful input.	No signal is provided for logical operation.
OPERATION AFTER FUNCTION IS FORBIDDEN	Output of functional instruction can not be connected to a contact, nor to conjunction with other signal that will be implemented by logical-or operation.	No logical operation with functional instruction output is permitted, except write coils.
WRITE COIL IS EXPECTED	Write coil is not found even if it is expected. Add proper write coil to the net.	Write coil is expected, but not found.
BAD COIL LOCATION	Coil can be located only at rightmost column. Any coil located at other place must be erased once, and place necessary coils in correct place.	Coil is located in bad position.
SHORT CIRCUIT	Find contact with terminals connected by short circuit, and correct connections.	Some contacts are connected with short circuit. CTR has a parameter number that is out of the range.
FUNCTION AFTER DIVERGENCE IS FORBIDDEN	Functional instruction can not be used in output section of net. If necessary, divide the net into plural nets.	Functional instruction is used in output section of net.
ALL COIL MUST HAVE SAME INPUT	Left terminals of all coils in a net must be connected to same input point.	When a net contains more than one coil, the coils should not have any contact beside them affects only of the coils.
BAD CONDITION INPUT	Check the connection of all condition inputs of the functional instruction. Especially for functional instruction that has more than one condition input, check if connections to condition inputs interfere with each other.	Some condition input of functional instruction is not connected correctly.
NO CONNECTION	Find gap that is expected to be connected, and correct the connection.	There is signal connected to nowhere.
NET IS TOO COMPLICATED	Examine every connection, and find unnecessarily bending connection, or coils that are connected to different point.	Net is too complicated to analyze.
PARAMETER IS NOT SUPPLIED	Enter all of the relay addresses, and parameters of functional instructions.	Relay with blank address, or blank parameter of functional instruction, is found.

Message	Faulty location/corrective action	Contents
TOO LARGE DATA FOR NET-EDITOR	Use the [NEXT NET] soft key to change the net subject to net editing.	The limit on the net editing screen was exceeded.
TOO MANY FUNCTIONS FOR NET-EDITOR	Use the [NEXT NET] soft key to change the net subject to net editing.	The number of functional instructions exceeded the limit on the net editing screen.
BAD DIAGRAM STRUCTURE	Check whether the connection shape of each relay or functional instruction is correct.	The circuit is too complicated to analyze.
NOT SUPPORT ENHANCED LADDER DIAGRAM	Replace the functional instruction with a functional instruction supporting an enhanced ladder diagram. Alternatively, use a net which does not use the enhanced ladder diagram function.	A ladder diagram using an enhanced ladder diagram function contains a functional instruction which does not support an enhanced ladder diagram.
TOO COMPLICATED CIRCUIT AROUND FUNCTION	Connect the circuit to which a branch is made according to the control condition of a functional instruction to the right bus line without merging it to the output circuit of the functional instruction. See X.xx.	The circuit around a functional instruction is too complicated to analyze.
CONNECT OUTPUT TO COIL DIRECTLY	Connect a coil immediately following the functional instruction.	No coil is connected immediately following a functional instruction.
SINGLE COIL IS EXPECTED	Only one coil can be connected to this functional instruction.	More than one coil is connected to a functional instruction to which only one coil can be connected.
INVALID CIRCUIT FOR FB PARAMETER	Specify a contact or coil for the parameter of the function block.	A functional instruction is connected for a parameter of a function block.
NO CONNECTION	Connect the broken connection.	The connection is broken.
PARAMETER IS NOT SUPPLIED	Set an address.	No address is set to the coil at the input or output section of a function block.
CAN NOT PLACE FB AND FUNCTION IN ONE NET	Delete the functional instruction placed in the same net as for the function block.	A functional instruction is placed in the same net as for a function block.
NO ASSIGNMENT TO FB CONTACT	Set a contact.	No contact is set in the input section of the BOOL type of a function block.

### Error messages that may be displayed on the TITLE DATA EDITOR screen

Message	Faulty location/corrective action	Contents
TOO MANY CHARACTERS	Make sure that the entered character string is within the allowable input length.	The number of characters in the entered character string exceeds the allowable input length. Some of the characters are discarded.
PROGRAM IS BEING MODIFIED	Disconnect the online communication with FANUC LADDER-III. Stop other applications from accessing the title data.	The title data cannot be displayed because online communication with FANUC LADDER-III is in progress or another application is accessing the title data.
THIS FUNCTION IS PROTECTED	Cancel the protection by the programmer protection function or 8-level protection function.	This function is protected by the programmer protection function or 8-level protection function.



## Error messages that may be displayed on the SYMBOL & COMMENT DATA EDITOR screen

Message	Faulty location/corrective action	Contents
TOO MANY CHARACTERS	Make sure that the entered address is within the allowable input length.	The number of characters in the entered address exceeds the allowable address input length.
ADDRESS IS REQUIRED	Enter an address correctly.	No address was entered during the batch input of address, symbol, and comment data using the SYMBOL & COMMENT EDITOR screen.
ILLEGAL PMC ADDRESS	Enter an address correctly.	The specified address is invalid, or the entered address character string contains a space or spaces.
THE ADDRESS ALREADY HAS AN ENTRY	Specify another address.	An already registered address was entered.
THE SYMBOL NAME IS ALREADY USED	Specify another symbol.	An already registered symbol was entered.
PMC ADDRESS MUST BE ENTERED	Enter a PMC address in the ADDRESS field.	No PMC address was entered when new symbol/comment data is registered.
TOO LONG SYMBOL NAME	Make sure that the symbol consists of 16 characters or less.	The entered symbol exceeds the specified number of characters.
TOO LONG COMMENT STRING	Make sure that the comment consists of 30 characters or less.	The entered comment exceeds the specified number of characters.
BAD SYMBOL NAME	Define a symbol that contains no space.	The entered symbol contains a space or spaces.
THE STRING IS NOT FOUND	Specify another character string for the search.	The search was done for the specified character string but did not find it.
OUT OF SPACE	Create free space for the sequence program, by deleting unnecessary ladder or message data.	The symbol/comment editing area has no free space.
PROGRAM IS BEING MODIFIED	Disconnect the online communication with FANUC LADDER-III. Stop other applications from accessing the symbol/comment data.	The symbol/comment data cannot be displayed because online communication with FANUC LADDER-III is in progress or another application is accessing the symbol/comment data.
THIS FUNCTION IS PROTECTED	Cancel the protection by the programmer protection function or 8-level protection function.	This function is protected by the programmer protection function or 8-level protection function.
BAD SYMBOL NAME	Change the symbol name.	The symbol name is invalid.
CANNOT EDIT ADDRESS AUTO ASSIGNED SYMBOL	Use FANUC LADDER-III to change the symbol.	The symbol whose PMC address is assigned automatically by compiling FANUC LADDER-III, can not edit.
ILLEGAL DATA TYPE	Enter a correct data type.	The specified data type is invalid.
ILLEGAL PROGRAM NAME	Enter a correct program name.	The specified program is invalid.
LINE FEED IS NOT AVAILABLE IN THIS DATA	Line feed code can be entered in comment data only. Do not enter it in other data.	Line feed code cannot be entered in this data.
LINE FEED IS NOT AVAILABLE IN THIS MODE	Enter Line feed code in the insert or overwrite mode.	Line feed code cannot be entered in this mode.
NO SYMBOL. PROGRAM SETTING IS IGNORED	Symbol name is required for local symbol.	The specified program is ignored because no symbol is specified.
NOTHING TO PASTE	You need to copy or cut character strings before you paste them.	You try to paste character strings without copying or cutting ones.
TOO LARGE DATA TO PASTE	Shorten the character string to copy or cut.	The character strings is too long to copy or cut.

Message	Faulty location/corrective action	Contents
UNAVAILABLE CHARACTERS WAS OMITTED.	Do not copy or cut characters which cannot be used at pasted position.	The characters which can not be used at pasted position, were omitted.

### Error messages that may be displayed on the MESSAGE DATA EDITOR screen

Message	Faulty location/corrective action	Contents
INPUT INVALID	Enter ";" in the 5th digit position in the batch message input process.	The format of message number is missing. The delimiter code - semicolon (;) - was not entered in the batch message input process.
ILLEGAL NUMBER	Enter a four-digit number as the message number.	The entered message number contains any nonnumeric character, or a number shorter than four digits was entered.
THE NUMBER IS OUT OF RANGE	Make sure that the entered message number with path number is in the range between 1000 and 4095. Another message number is in the range between 1000 and 9999.	The entered message number is out of range.
CLOSING "@" IS NOT FOUND	When entering kana or other Japanese characters, make sure that they are enclosed within a pair of @ signs.	One of the @ sign pair is missing.
BAD NUMBER OF CHARACTERS IN "@-@"	Enter a character string correctly between a pair of @ signs.	The number of characters entered between the pair of @ signs is not even.
ILLEGAL CHARACTER IN "@-@"	Enter a character string correctly between a pair of @ signs.	One or more invalid character codes exist between the pair of @ signs.
BAD NUMBER OF CHARACTERS FOR 2-BYTE CODE	Enter a two-byte code correctly between @02 and 01@.	The number of characters in the two-byte code (characters entered between @02 and 01@) is not a multiple of four.
ILLEGAL 2-BYTE CODE	Enter a two-byte code correctly between @02 and 01@.	The two-byte code (characters entered between @02 and 01@) contains one or more characters other than the JIS codes.
CLOSING CONTROL CODE "01" IS NOT FOUND	Enter the closing control code.	The two-byte code (characters entered between @02 and 01@) lacks the closing control code (01).
CONTROL CODE "XX" IS REPEATED	Remove any repeated control code.	The starting control code (02), closing control code (01), and/or umlaut code (0D) is repeated.
CLOSING "]" IS NOT FOUND	Make sure that the "[" and "]" codes are entered in pairs.	The delimiter codes for numerical data are not entered in pairs.
BAD NUMERICAL DATA FORMAT	Specify the numerical data correctly.	The format of the numerical data is invalid.
BAD PMC ADDRESS FOR NUMERIAL DATA	Enter an available address.	The address section of the numerical data is invalid.
PROGRAM IS BEING MODIFIED	Disconnect the online communication with FANUC LADDER-III. Stop other applications from accessing the message data.	The message data cannot be displayed because online communication with FANUC LADDER-III is in progress or another application is accessing the message data.
THIS FUNCTION IS PROTECTED	Cancel the protection by the programmer protection function or 8-level protection function.	This function is protected by the programmer protection function or 8-level protection function.

### Error messages that may be displayed on the I/O MODULE EDITOR screen

Message	Faulty location/corrective action	Contents
GROUP NUMBER IS TOO LARGE	Specify 15 or a smaller value as the group number.	The entered group number is too large.
BASE NUMBER IS TOO LARGE	Specify base number 0 for I/O Unit-B (##, #1 - #10).	The entered base number is too large.
SLOT NUMBER IS TOO LARGE	Specify 30 or a smaller value as the slot number for I/O Unit-B (##, #1 - #10). For other I/O units, specify 10 or a smaller value.	The entered slot number is too large.
SLOT NUMBER IS TOO SMALL	Check the I/O unit name.	The entered slot number is too small.
I/O UNIT NAME MISMATCH	Check the I/O unit name or address.	The input I/O unit is assigned to the Y address, or the output I/O unit is assigned to the X address.
ILLEGAL I/O UNIT NAME	Enter an I/O unit that is listed in Tables 3.2 (a) to 3.2 (c) in Chapter 3.	The entered I/O unit name is invalid.
NOT ENOUGH SPACE	Enter the data again after creating free space by deleting the data allocated behind the current cursor position or by other adequate means.	There is not enough free address space for the size of the I/O unit you are going to assign. This error also occurs if you attempt to assign the I/O unit to an already allocated address space.
PROGRAM IS BEING MODIFIED	Disconnect the online communication with FANUC LADDER-III. Stop other applications from accessing the I/O module data.	The I/O module data cannot be displayed because online communication with FANUC LADDER-III is in progress or another application is accessing the I/O module data.
THIS FUNCTION IS PROTECTED	Cancel the protection by the programmer protection function or 8-level protection function.	This function is protected by the programmer protection function or 8-level protection function.

### Error messages that may be displayed on the I/O CONFIGURATION EDITOR (I/O Link *i* assignment) screen

Message	Faulty location / corrective action	Contents
TOO MANY GROUPS (CHx)	Delete any unnecessary group, then create a new group.	A new group cannot be created because the maximum number of groups per channel is exceeded.
TOO MANY SLOTS (CHx)	Delete any unnecessary slot, then create a new slot.	A new slot cannot be created because the maximum number of slots per channel (256 slots) is exceeded.
TOO MANY SLOTS IN A GROUP (CHx, Gy)	Delete any unnecessary slot, then create a new slot.	A new slot cannot be created because the maximum number of slots per channel (32 slots) is exceeded.
NO SLOT(Gxx)	Add a slot.	There is no slot in group Gxx.
SLOT NUMBER IS REQUIRED	Enter a slot number.	No slot number is entered for a slot.
SLOT NUMBER DUPLICATE	Change the slot number used more than once.	More than one slot data item having the same slot number is found in the same group.
CAN NOT DELETE MPG SLOT	Turn the MPG flag off in the group setting screen.	No MPG slot can be deleted in the slot setting screen.
ILLEGAL SLOT NUMBER	Enter a slot number not greater than 32.	The entered slot number is greater than 32.

Message	Faulty location / corrective action	Contents
ILLEGAL PMC ADDRESS	Enter a correct PMC address again.	The entered PMC address is invalid. Alternatively, no PMC address is entered.
ILLEGAL SIZE	Enter a correct size again.	The entered size is outside the PMC address range. Alternatively, a value of 0 is entered as the size.
SLOT HAS NO ASSIGNMENT	Enter a PMC address and size.	For a slot, a PMC address or size is not entered for both DI and DO.
ILLEGAL COMMENT	Enter a correct comment again.	An entered comment does not conform to the extended symbol and comment format.
PMC ADDRESS OVERLAPPED (PMCm X(Y)nnnn)	Enter the PMC address or size so that it is set only once.	Address PMCm X(Y)nnnn is also assigned to another slot in I/O Link <i>i</i> assignment data.
TOO MANY OUTPUT POINTS (CHx, Gyy)	Reduce the number of output points of the group.	The number of output points of the I/O Link <i>i</i> group set for Gyy of CHx exceeds the upper limit (65 bytes by default or 29 bytes for the safety I/O device).
TOO MANY INPUT POINTS (CHx, Gyy)	Reduce the number of input points of the group.	The number of input points of the I/O Link <i>i</i> group set for Gyy of CHx exceeds the upper limit (65 bytes by default or 29 bytes for the safety I/O device).
TOO MANY OUTPUT POINTS (CHx)	Reduce the number of output points in the channel.	Warning message. The number of I/O Link <i>i</i> output points set in CHx exceeds the upper limit.
TOO MANY INPUT POINTS (CHx)	Reduce the number of input points in the channel.	Warning message. The number of I/O Link <i>i</i> input points set in CHx exceeds the upper limit.
TOO MANY CHARACTERS	Enter a comment within the input field.	The number of characters in an entered comment exceeds the input width.
THE ADDRESS IS NOT FOUND		The specified address is not found.
INPUT INVALID	Enter a correct numeric value.	A numeric value is invalid.
I/O CONFIG DATA IS BROKEN	Enter an I/O configuration file again.	I/O Link <i>i</i> assignment data is invalid.
TOO MANY SAFETY I/O GROUPS	Reduce the number of I/O Link <i>i</i> safety I/O groups.	Warning message. More than four I/O Link <i>i</i> safety I/O groups are specified either on the PMC or DCS side in the entire system.
TOO MANY ASSIGNMENTS (H.SPEED)(CHn,Gyy)	When a group in the high-speed transfer cycle mode is connected to I/O Link <i>i</i> , correct assignment so that the assignment for each group is performed within the quartered transfer timing with referencing Subsection 3.6.4 "Transfer Cycle".	Warning message. In CHn, group yy and following exceed the transfer capacity limit in transfer timing assignment processing when the high-speed mode of I/O Link <i>i</i> is used.
BASIC GROUP INVALID	Correct the number of basic groups for the I/O assignment selection function of I/O Link <i>i</i> .	The number of basic groups for the I/O assignment selection function of I/O Link <i>i</i> is invalid.
UNAVAILABLE ADDRESS FOR DCSPMC	Use addresses X0/Y0 and following.	Addresses X200/Y200, X400/Y400, or X600/Y600 and following are assigned to a group for which DCSPMC is specified for the PMC path.

Message	Faulty location / corrective action	Contents
THIS DATA IS BEING MODIFIED	Disconnect the online communication with FANUC LADDER-III. Stop other applications from accessing the I/O configuration data.	I/O configuration data cannot be displayed because online communication with FANUC LADDER-III is in progress or another application is accessing the I/O configuration data.
INTERNAL ERROR(0xCxxxxxx)	Contact us, and report the displayed message correctly.	This error occurs due to an internal factor. An error code is indicated in parentheses.

### Error messages that may be displayed on the SYSTEM PARAMETER screen

Message	Faulty location/corrective action	Contents
INPUT INVALID	Enter a correct numerical value.	The entered numerical value or its input format is invalid.
SYMBOL UNDEFINED	Enter a defined symbol or bit address.	An undefined symbol character string was entered.
PROGRAM IS BEING MODIFIED	Disconnect the online communication with FANUC LADDER-III. Stop other applications from accessing the system parameter data.	The system parameter data cannot be displayed because online communication with FANUC LADDER-III is in progress or another application is accessing the system parameter data.
THIS FUNCTION IS PROTECTED	Cancel the protection by the programmer protection function or 8-level protection function.	This function is protected by the programmer protection function or 8-level protection function.

### Error messages that may be displayed on the SIGNAL STATUS screen

Message	Faulty location/corrective action	Contents
INPUT INVALID	Enter a correct numerical value.	The entered numerical value or its input format is invalid.
SYMBOL UNDEFINED	Enter a defined symbol or bit address.	An undefined symbol character string was entered.
THIS FUNCTION IS PROTECTED	Cancel the protection by the programmer protection function or 8-level protection function.	This function is protected by the programmer protection function or 8-level protection function.

### Error messages that may be displayed on the PMC PARAM screen

Message	Faulty location/corrective action	Contents
INPUT INVALID	Enter a numerical value correctly.	The entered numerical value or its input format is invalid.
MUST BE IN EMERGENCY STOP OR IN MDI MODE	Set a mode to MDI or emergency stop.	The status of NC is not MDI mode or emergency stop.
PWE MUST BE ON	Set the "PWE" to "1" in NC setting screen.	The "PWE" in NC setting screen is "0".
EITHER PWE OR KEY4 MUST BE ON	Set the "PWE" to "1" in NC setting screen or set the key "KEY4" to "1".	The "PWE" in NC setting screen is "0" or the program protect key "KEY4" is "0".
THIS FUNCTION IS PROTECTED	Cancel the protection by the programmer protection function or 8-level protection function.	This function is protected by the programmer protection function or 8-level protection function.

### Error messages that may be displayed on the SIGNAL TRACE screen

Message	Faulty location/corrective action	Contents
TRACE FUNCTION IS ALREADY IN USE.	Wait until FANUC LADDER-III or some other application finishes using the trace function before executing it.	FANUC LADDER-III or some other application is currently using the trace function.

Message	Faulty location/corrective action	Contents
NO SAMPLING ADDRESS.	Specify a bit address as a sampling address in the trace parameter.	No sampling address is specified in the trace parameter.
NO STOP TRIGGER ADDRESS.	Specify a bit address as the stop trigger address in the trace parameter.	The stop trigger address is not specified in the trace parameter.
NO SAMPLING TRIGGER ADDRESS.	Specify a bit address as the sampling trigger address in the trace parameter.	The sampling trigger address is not specified in the trace parameter.
USB MEMORY IS USED BY OTHER FUNCTION.	Terminate another function that is using the USB memory, then perform operation again.	The USB memory is being used by another function.
USB MEMORY IS NOT READY.	Check whether a USB memory is inserted.	No USB memory is inserted.
USB MEMORY IS FULL.	Delete any unnecessary files and allocate a required capacity.	The USB memory is full.
USB MEMORY HAS BEEN REMOVED	Insert the USB memory, then execute input/output operation again.	A USB memory is removed while it is being accessed.
USB MEMORY IS NOT FORMATTED	Replace the USB memory with another one.	The inserted USB memory cannot be recognized.
USB HARDWARE ERROR (xxxxxxxx)	Replace the USB memory with another one. If this error still occurs after replacement, contact us, and report the displayed message correctly.	This error occurs due to a USB hardware failure. An error code is indicated in parentheses.
INTERNAL ERROR (xxxxxxxx)	Contact us, and report the displayed message correctly.	This error occurs due to an internal factor. An error code is indicated in parentheses.

### Error messages that may be displayed on the trace setting screen

Message	Faulty location/corrective action	Contents
INPUT INVALID	Enter a numerical value that is within the specified data range of the relevant trace parameter.	A nonnumeric value or an out-of-range parameter value was entered.
SYMBOL UNDEFINED	Enter a defined symbol or bit address.	An undefined symbol character string was entered.
BIT ADDRESS IS REQUIRED	Specify a bit address as the stop or sampling trigger address.	A byte address was specified as the stop or sampling trigger address.
INVALID STOP TRIGGER ADDRESS	Enter a PMC signal address that can be used as the stop trigger address.	The bit address entered as the stop trigger address is invalid.
INVALID SAMPLING TRIGGER ADDRESS	Enter a PMC signal address that can be used as the sampling trigger address.	The bit address entered as the sampling trigger address is invalid.
UNSUPPORTED TRACE SETTING FILE	This file cannot be handled. Set data in the TRACE SETING screen.	An attempt was made to read a trace setting file that could not be handled.
INVALID SETTING VALUE (LINE n)	Output the trance setting file again. Alternatively, set data in the TRACE SETING screen.	An invalid setting is found. The file may be damaged.
SAMPLING TIME/FRAME WAS ADJUSTED	Check the data on the TRACE SETING screen.	The values are adjusted according to the read data. (This is warning.)
UNKNOWN SETTING WAS SKIPPED(LINE n)	Check the read trace data.	An unknown trace setting item is found and ignored. (This is warning.)
INVALID SAMPLING ADDRESS WAS FOUND	Check the read trace data.	An invalid sampling address is found. (This is warning.)

Message	Faulty location/corrective action	Contents
TOO MANY SAMPLING ADDRESSES	Check the read trace data.	The number of sampling addresses exceeds the upper limit. (This is warning.)
THE FILE IS NOT TRACE SETTING FILE	This file cannot be read. Specify a correct file.	An attempt was made to read a file which was not a trace setting file.
FILE NAME CONTAINS RESERVED WORD.	Correct file name.	"FORFANUC" cannot be used in the top of the file name.
USB MEMORY IS USED BY OTHER FUNCTION.	Terminate another function that is using the USB memory, then perform operation again.	The USB memory is being used by another function. Another function is formatting the USB memory.
USB MEMORY IS NOT READY.	Check whether a USB memory is inserted.	No USB memory is inserted.
USB MEMORY HAS BEEN REMOVED	Insert the USB memory, then execute input/output operation again.	A USB memory is removed while it is being accessed.
USB MEMORY IS NOT FORMATTED	Replace the USB memory with another one.	The inserted USB memory cannot be recognized.
FILE NAME IS INVALID.	Correct the file name.	An invalid character is found in a file name.
FOLDER NAME CANNOT BE SPECIFIED.	A folder name is specified. Specify an appropriate file name.	An attempt was made to read or write a folder.
USB HARDWARE ERROR (xxxxxxxxxx)	Replace the USB memory with another one. If this error still occurs after replacement, contact the FANUC service center, and report the displayed message correctly.	This error occurs due to a USB hardware failure. An error code is indicated in parentheses.
INTERNAL ERROR (xxxxxxxxxx)	Contact us, and report the displayed message correctly.	This error occurs due to an internal factor. An error code is indicated in parentheses.

### Error messages that may be displayed on the I/O diagnosis screen

Message	Faulty location/corrective action	Contents
ENTER STRING TO SEARCH.	Enter a string before starting a search.	No search string is specified.
I/O DIAGNOSIS FUNCTION IS NOT SUPPORTED	To use the I/O diagnosis function, update the PMC system software.	The I/O diagnosis function cannot be used because the PMC system software is an older version.
INPUT INVALID	Check the entered string.	The entered string is invalid.
LADDER PROGRAM IS BROKEN	Check the information displayed on the PMC alarm screen and reload the program.	The program is corrupted.
NO GROUP FORMAT.	Use [GROUP] on the I/O diagnosis (setting) screen.	No group display is set.
PROGRAM IS BEING MODIFIED.	Retry after completing the function that is using the program.	The program cannot be referenced because it is being used by another function.
REACHED TO THE END OF SYMBOL DATA.	To make another search, specify a string again.	The search has been completed until the end of the data has been reached.
SYMBOL ORDER IS NOT AVAILABLE.	Use the FANUC LADDER-III to convert the program to one with an expanded function.	The format of this program does not allow sorting and display in symbol order.
THE GROUP IS NOT FOUND	Check the specified group.	The specified group is not found.

Message	Faulty location/corrective action	Contents
FORCING IS PROTECTED ON THIS PATH.	Disable the programmer protection function.	The forced input/output function is currently protected on the selected PMC path.
THE STRING IS NOT FOUND	Check the specified string.	The specified string is not found.

## A.2.4 I/O Communication Error Messages

The error messages that may appear on the I/O screen and their meanings and actions are listed below.

### Error messages displayed during memory card I/O operation

Message	Faulty location/corrective action	Contents
MEMORY CARD IS NOT READY	Check whether a memory card is installed.	No memory card is installed.
MEMORYCARD IS FULL	Delete files to create available space.	There is no available space in the memory card.
MEMORYCARD IS WRITE PROTECTED	Release the write protection of the memory card.	The memory card is write-protected.
MEMORYCARD IS NOT FORMATTED	Format the memory card in FAT16. (It cannot be recognized if formatted in FAT32.)	The memory card cannot be recognized.
TOO MANY FILES IN MEMORYCARD	Delete unnecessary files to reduce the number of files.	There are too many files.
FILE NOT FOUND	On the list screen, check the file name or file number.	The specified file cannot be found.
FILE IS READ-ONLY	Check the attributes of the file.	Write to the specified file is not permitted.
FILE NAME IS INVALID	Specify the file name in MS-DOS form.	The file name is illegal.
COULD NOT FORMAT MEMORY CARD	The NC cannot format this memory card. Format the memory card in FAT16 using another PC. (It cannot be recognized if formatted in FAT32.)	The memory card cannot be formatted.
UNSUPPORTED MEMORYCARD	Replace the memory card with another one.	This memory card is not supported.
CAN NOT DELETE FILE	Check the attributes of the file.	An error occurred when a file was deleted from the memory card.
MEMORYCARD BATTERY ALARM	Replace the battery of the memory card.	The battery of the memory card has become weak.
THIS FILE NAME IS ALREADY USED	Change the file name to another one.	The file name is already used.
MEMORYCARD ACCESS ERROR	Replace the memory card with another one.	The memory card cannot be accessed.
DIFFERENCE FOUND		File comparison detected a mismatch.
MEMORY CARD IS LOCKED BY OTHER FUNCTION	Wait until the PMC user completes processing, then retry.	Another PMC user is using the memory card.
MEMORY CARD HEADER ROM DATA ID IS ILLEGAL	This file cannot be read. Check the type of the file.	An attempt was made to read a file, but its ROM data ID was illegal.
FILE NUMBER CAN NOT SELECTED	If the file does not exist, the key entry is invalid. If this error occurs even when the cursor is placed at a file name, contact the FANUC service center.	The file number cannot be selected.
THE FILE NUMBER DOES NOT EXIST	Check the total number of files on the list screen.	The entered file number is not present. The entered number exceeds the total number of files.



Message	Faulty location/corrective action	Contents
FILE NUMBER IS RESTRICTED TO "128"	Enter a numeric value not exceeding 128.	A value up to 128 can be entered as the file number.
MEMORY CARD IS USED BY OTHER FUNCTION	Retry after terminating the other function that is currently using the memory card.	Some other function is currently using the memory card.
MEMORY CARD IS WRITE PROTECTED	Cancel the write protection of the memory card, or use another memory card that is not write protected.	The memory card is write protected.
UNSUPPORTED MEMORY CARD	Use another memory card.	This is an unsupported type of memory card.
COULD NOT DELETE FILE	Check the read/write permission attribute of the file.	The file cannot be deleted.
TRACE FILE NUMBER IS OVER	Delete unnecessary old trace result file or files.	No more trace result file can be created because the maximum trace result file number (file extension) has been reached.
UNSUPPORTED TRACE SETTING FILE	This file cannot be handled. Set data in the TRACE SETING screen.	An attempt was made to read a trace setting file that could not be handled.
INVALID SETTING VALUE (LINE n)	Output the trance setting file again. Alternatively, set data in the TRACE SETING screen.	An invalid setting is found. The file may be damaged.
SAMPLING TIME/FRAME WAS ADJUSTED	Check the data on the TRACE SETING screen.	The values are adjusted according to the read data. (This is warning.)
UNKNOWN SETTING WAS SKIPPED(LINE n)	Check the read trace data.	An unknown trace setting item is found and ignored. (This is warning.)
INVALID SAMPLING ADDRESS WAS FOUND	Check the read trace data.	An invalid sampling address is found. (This is warning.)
TOO MANY SAMPLING ADDRESSES	Check the read trace data.	The number of sampling addresses exceeds the upper limit. (This is warning.)
INTERNAL ERROR (xxxxxxxx)	Contact the FANUC service center, and report the displayed message correctly.	An error due to an internal factor occurred. Details on the error are displayed in parentheses.

### Error messages displayed during USB memory I/O operation

Message	Faulty location/corrective action	Contents
FILE NAME CONTAINS RESERVED WORD.	Correct file name.	"FORFANUC" cannot be used in the top of the file name.
USB MEMORY HAS BEEN REMOVED	Insert the USB memory, then execute input/output operation again.	A USB memory is removed while it is being accessed.
USB MEMORY IS NOT READY.	Check whether a USB memory is inserted.	No USB memory is inserted.
USB MEMORY IS USED BY OTHER FUNCTION.	Terminate another function that is using the USB memory, then perform operation again.	The USB memory is being used by another function.
THIS FILE NAME IS ALREADY USED. OVERWRITE IT?	Follow the message, and overwrite the file or specify another file name to write data.	An existing file name is specified as the write destination.
FILE NOT FOUND	Check the file name or number on the file list screen.	The specified file is not found.
USB MEMORY IS FULL.	Delete any unnecessary files and allocate a required capacity.	The USB memory is full.
FILE IS READ-ONLY.	Specify another file or check the file attribute and delete the read-only attribute.	The specified file is read-only.

Message	Faulty location/corrective action	Contents
USB MEMORY IS NOT FORMATTED	Replace the USB memory with another one.	The inserted USB memory cannot be recognized.
FILE NAME IS INVALID.	Correct the file name.	An invalid character is found in a file name.
DIFFERENCE FOUND		File comparison detected a mismatch.
THE FILE NUMBER DOES NOT EXIST	Check the total number of files on the list screen.	The entered file number is not found. The entered number is greater than the total number of files.
FILE NUMBER IS RESTRICTED TO "128"	Enter a numeric value not greater than 128.	A value up to 128 can be entered as the file number.
FOLDER CANNOT BE SPECIFIED.	<1> The specified number indicates a folder. Enter an appropriate number. <2> No folder can be selected in the file list screen.	<1> The specified number indicates a folder. <2> An attempt was made to select a folder in the file list screen.
THIS FILE CANNOT BE SPECIFIED.	<1> The file name corresponding to the specified file number consists of more than 32 characters. Enter an appropriate number. <2> No file having a file name consisting of more than 32 characters can be selected in the file list screen.	<1> The file name corresponding to the specified file number consists of more than 32 characters. <2> An attempt was made to select a file having a file name consisting of more than 32 characters.
USB HARDWARE ERROR (xxxxxxxx)	Replace the USB memory with another one. If this error still occurs after replacement, contact the FANUC service center, and report the displayed message correctly.	This error occurs due to a USB hardware failure. An error code is indicated in parentheses.
INTERNAL ERROR (xxxxxxxx)	Contact us, and report the displayed message correctly.	This error occurs due to an internal factor. An error code is indicated in parentheses.

### Error messages displayed during flash ROM I/O operation

Message	Faulty location/corrective action	Contents
NOT IN EMG STOP MODE	Place the system in the emergency stop state.	The system is not in the emergency stop state.
INVALID LADDER PROGRAM	Check the program.	The transfer program is illegal.
DIFFERENCE FOUND		A file comparison detected a mismatch.
FLASH ROM IS LOCKED BY OTHER FUNCTION	Wait until the PMC user completes processing, then retry.	Another PMC user is using the flash ROM.
FLASH ROM HEADER ROM DATA ID IS ILLEGAL	This file cannot be read. Check the type of the file.	An attempt was made to read a file, but its ROM data ID was illegal.
FLASH ROM IS USED BY OTHER FUNCTION	This file cannot be read. Check the type of the file.	The ROM data ID of the file you attempted to read is invalid.
INTERNAL ERROR (xxxxxxxx)	Contact the FANUC service center, and report the displayed message correctly.	An error due to an internal factor occurred. Details on the error are displayed in parentheses.

## Error messages displayed during FLOPPY or other input/output device I/O operation

Message	Faulty location/corrective action	Contents
ILLEGAL PMC PARAMETER FORMAT	Specify a file of the PMC parameter format. Also, check the specified file to see whether its content is not disrupted.	The specified file is not of the PMC parameter format.
ILLEGAL HANDY FILE FORMAT	Specify a file of the handy file format. Also, check the specified file to see whether its content is not disrupted.	The specified file is not of the handy file format.
UNKNOWN FILE FORMAT	Specify file of recognizable format such as PMC parameter format, or check the contents of the file.	Can not recognize the format of specified file.
FILE NAME OR FILE NUMBER IS REQUIRED	Specify file name or file number for the operation.	Need file name or file number to identify file to read, compare, or delete.
COMMUNICATION TIMEOUT	Check the communication parameters such as baud rate, and retry to communicate.	Communication with the I/O device has been timeout.
I/O DEVICE IS NOT ATTACHED OR IN ERROR STATUS	Check the power of I/O device is ON. Check the I/O device is connected. Check the cable that connects I/O device with PMC is correct one. If some error has occurred in I/O device, solve it.	Any I/O device is not connected, or some error has occurred in it.
RECEIVED BAD DATA: CHECK THE COMMUNICATION PARAMETERS	Check the PMC's communication parameters such as baud rate match the ones of I/O device.	Invalid data has been received.
RECEIVED DATA HAS OVERRUN	Check the communication parameters about flow control.	Too many data have received at once.
OTHERS FUNCTION IS USING THIS CHANNEL	Use the other channel, or stop the function.	Others function is using this channel.
BAD COMMUNICATION PARAMETER	Check the communication parameters such as baud rate.	Setting parameters of communication are not correct.
OTHER FUNCTION IS USING I/O FUNCTION	Wait until function that using I/O function do finish, or stop the function.	Another function such as FANUC LADDER-III is using I/O function.
UNKNOWN HANDY FILE FORMAT DATA	Check the file.	The received data is not a program of the PMC system or is a program of some other incompatible type.
ILLEGAL BAUD RATE SETTING	Set a valid baud rate.	The set baud rate is invalid.
ILLEGAL CHANNEL NUMBER	Set a valid channel number.	The set channel number is invalid.
ILLEGAL PARITY BIT SETTING	Set a valid parity bit.	The set parity bit is invalid.
ILLEGAL STOP BIT SETTING	Set a valid stop bit.	The set stop bit is invalid.
ILLEGAL WRITE CODE SETTING	Set a valid output code.	The set output code is invalid.
SEQUENCE PROGRAM IS IN USE BY ONLINE FUNCTION	Wait until On-line function, do finish the using I/O function. In general, both of I/O function and On-line function should not be used at the same time.	Can not input/output of sequence program, because On-line function is using sequence program.

## Common error messages that may be displayed on individual devices during the I/O operations

Alarm number	Faulty location/corrective action	Contents
ERROR OCCURS IN LADDER PROGRAM	Check the PMC alarm screen and correct the indicated program error accordingly.	Data cannot be output because there is an error in the ladder program.
UNKNOWN DATA TYPE	Check the file.	The PMC type of the input data is unknown.
MUST BE IN EMERGENCY STOP	Set the NC to the emergency stop state.	The NC is not in the emergency stop state when the PMC parameter is read.
PWE MUST BE ON	Set PWE to 1 on the NC setting screen.	PWE on the NC setting screen is 0 during reading from the PMC parameter.
MUST BE IN EDIT MODE	Set the NC to the EDIT mode.	The NC is not in the EDIT mode during writing to the PMC parameter.
THIS FUNCTION IS NOT ALLOWED	Release the protection by the programmer protection function or 8-level protection function.	Protection is made by the programmer protection function or 8-level protection function.
PMC PARAMETER IS LOCKED BY OTHER FUNCTION	Retry after terminating the other function that is currently using the PMC parameter.	The PMC parameter is currently used by some other function and cannot be referenced by this function.
THIS DEVICE IS USED BY OTHER FUNCTION	Retry after terminating the other function that is currently using the specified device.	The specified device is currently used by some other function and cannot be used by this function.
PMC PARAMETER IS PROTECTED BY OTHER FUNCTION	Retry after terminating the other function that is currently using the PMC parameter.	The PMC parameter is currently used by some other function and cannot be changed by this function.
LADDER TYPE UNMATCH	Specify a program of a valid type.	The specified program is of a different type and cannot be read.
TOO LARGE SEQUENCE PROGRAM	Check the file. Or, change to a step number option that allows you to set a larger program size.	The ladder program is too large to read.
SEQUENCE PROGRAM IS USED BY OTHER FUNCTION	Retry after terminating the other function that is currently displaying the ladder program.	The ladder program is currently used by some other function and cannot be referenced by this function.
INVALID I/O CONFIGURATION DATA	Read correct I/O configuration file.	Invalid I/O configuration data was read and any of the following operations was performed: - Writing it to the memory card - Comparing it with a memory card file USB - Writing it to flash ROM - Comparing it with flash ROM
TOO LARGE I/O CONFIGURATION DATA	Check the I/O configuration file.	The I/O configuration file is too large to read.
I/O CONFIGURATION DATA IS USED BY OTHER FUNCTION	Terminate another function that is using the I/O configuration data, then execute operation again.	I/O configuration data is being used by another function (such as FANUC LADDER-III).

## A.3 ALARM LIST (SERIAL SPINDLE)

When a serial spindle alarm occurs, the following number is displayed on the CNC.

### NOTE

\*1 Note that the meanings of the Spindle Amplifier (SP) indications differ depending on which LED, the red or yellow LED, is on. When the red LED is on, the Spindle Amplifier (SP) indicates a 2-digit alarm number. When the yellow LED is on, the SP indicates an error number that designates a sequence problem (for example, when a rotation command is entered with the emergency stop state not released).

See "Error Codes (Serial Spindle)."

\*2 For information about serial spindle alarms for numbers that are not listed below, refer to the following documents according to the actual spindle motor to be connected.

- FANUC AC SPINDLE MOTOR  $\alpha$ i series MAINTENANCE MANUAL (B-65285EN)
- Technical reports etc.

Number	Message	SP indication (*1)	Faulty location and remedy	Description
SP9001	MOTOR OVERHEAT	01	<ol style="list-style-type: none"> <li>1 Check and correct the peripheral temperature and load status.</li> <li>2 If the cooling fan stops, replace it.</li> </ol>	<p>The internal temperature of the motor exceeds the specified level.</p> <p>The motor is used in excess of the continuous rating, or the cooling component is abnormal.</p>
SP9002	EX DEVIATION SPEED	02	<ol style="list-style-type: none"> <li>1 Check and correct the cutting conditions to decrease the load.</li> <li>2 Correct parameter No. 4082.</li> </ol>	<p>The motor speed cannot follow a specified speed.</p> <p>An excessive motor load torque is detected.</p> <p>The acceleration/deceleration time in parameter No. 4082 is insufficient.</p>
SP9003	DC-LINK FUSE IS BROKEN	03	<ol style="list-style-type: none"> <li>1 Replace the Spindle Amplifier (SP).</li> <li>2 Check the motor insulation status.</li> </ol>	<p>The Power Supply becomes ready (00 is indicated), but the DC link voltage is too low in the Spindle Amplifier (SP).</p> <p>The fuse in the DC link section in SP is blown. (The power device is damaged or the motor is ground-fault.)</p>
SP9004	PS IMPROPER INPUT POWER		Check the state of the input power supply to the Power Supply (PS).	The power supply (PS) detected a power supply failure. (Power Supply alarm 14)
SP9006	THERMAL SENSOR DISCONNECT	06	<ol style="list-style-type: none"> <li>1 Check and correct the parameter.</li> <li>2 Replace the feedback cable.</li> </ol>	The temperature sensor of the motor is disconnected.

Number	Message	SP indication (*1)	Faulty location and remedy	Description
SP9007	OVER SPEED	07	Check for a sequence error. (For example, check whether spindle synchronization was specified when the spindle could not be turned.)	The motor speed has exceeded 115% of its rated speed. When the spindle axis was in position control mode, position error were accumulated excessively (SFR and SRV were turned off during spindle synchronization.)
SP9009	OVERHEAT MAIN CIRCUIT	09	<ol style="list-style-type: none"> <li>1 Improve the heat sink cooling status.</li> <li>2 If the heat sink cooling fan stops, replace the Spindle Amplifier (SP).</li> </ol>	The temperature in the power semiconductor cooling radiator is abnormally high.
SP9010	LOW VOLT INPUT POWER	10	<ol style="list-style-type: none"> <li>1 Replace the cables.</li> <li>2 Replace the SP control printed circuit board.</li> </ol>	A drop in the input power voltage in the Spindle Amplifier (SP) is detected.
SP9011	PS OVER VOLT. DC LINK		<ol style="list-style-type: none"> <li>1 Check the selected Power Supply (PS).</li> <li>2 Check the input power voltage and change in power during motor deceleration. If the voltage exceeds 253 VAC (for the 200-V system) or 530 VAC (for the 400-V system), improve the power supply impedance.</li> </ol>	Overvoltage of the DC link section of the Power Supply (PS) was detected. (Power Supply alarm indication: 07) PS selection error. (The maximum output specification of the PS is exceeded.)
SP9012	OVERCURRENT POWER CIRCUIT	12	<ol style="list-style-type: none"> <li>1 Check the motor insulation status.</li> <li>2 Check the spindle parameters.</li> <li>3 Replace the Spindle Amplifier (SP).</li> </ol>	The motor current is abnormally high. A motor-specific parameter does not match the motor model. Poor motor insulation
SP9013	CPU DATA MEMORY FAULT	13	Replace the Spindle Amplifier (SP) control printed circuit board.	Abnormality in a Spindle Amplifier (SP) control circuit component is detected. (RAM within the Spindle Amplifier (SP) is abnormal.)
SP9014	SOFTWARE SERIES MISMATCH	14	Replace the spindle software.	A Spindle Amplifier (SP) that is not registered in the spindle software is used.
SP9015	SPINDLE SWITCHING FAULT	15	<ol style="list-style-type: none"> <li>1 Check and correct the ladder sequence.</li> <li>2 Replace the switching MCC.</li> </ol>	The switch sequence in spindle switching/speed range switching operation is abnormal. The switching MCC contact status check signal and command do not match.
SP9016	RAM ERROR	16	Replace the Spindle Amplifier (SP) control printed circuit board.	Abnormality in a Spindle Amplifier (SP) control circuit component is detected. (RAM for external data is abnormal.)
SP9017	ID NUMBER PARITY ERROR	17	Replace the Spindle Amplifier (SP)	Abnormality in Spindle Amplifier (SP) ID data is detected.

Number	Message	SP indication (*1)	Faulty location and remedy	Description
SP9018	SUMCHECK ERROR PROGRAM ROM	18	Replace the Spindle Amplifier (SP) control printed circuit board.	Abnormality in a Spindle Amplifier (SP) control circuit component is detected. (Program ROM data is abnormal.)
SP9019	EXCESS OFFSET CURRENT U	19	Replace the Spindle Amplifier (SP).	Abnormality in a Spindle Amplifier (SP) component is detected. (The initial value for the U phase current detection circuit is abnormal.)
SP9020	EXCESS OFFSET CURRENT V	20	Replace the Spindle Amplifier (SP).	Abnormality in a Spindle Amplifier (SP) component is detected. (The initial value of the V phase current detection circuit is abnormal.)
SP9021	POS SENSOR POLARITY ERROR	21	Check and correct the parameters. (parameters Nos. 4000#0, 4001#4)	The polarity parameter setting of the position sensor is wrong.
SP9022	SP AMP OVER CURRENT	22	1 Review operation conditions (acceleration/ deceleration and cutting) to reduce the load. 2 Check and correct the parameters.	A Spindle Amplifier (SP) overload current was detected.
SP9024	SERIAL TRANSFER ERROR	24	1 Place the CNC-to-spindle cable away from the power cable. 2 Replace the cable.	The CNC power is turned off (normal power-off or broken cable). An error is detected in communication data transferred to the CNC.
SP9027	DISCONNECT POSITION CODER	27	Replace the cable.	The spindle position coder (connector JYA3) signal is abnormal.
SP9029	OVERLOAD	29	Check and correct the load status.	Excessive load has been applied continuously for a certain period of time. (This alarm is issued also when the motor shaft has been locked in the excitation state.)
SP9030	OVERCURRENT		Check and correct the power supply voltage.	Overcurrent is detected in Power Supply (PS) main circuit input. (Power Supply alarm indication: 01) Unbalanced power supply. PS selection error (The maximum PS output specification is exceeded.)
SP9031	MOTOR LOCK	31	1 Check and correct the load status. 2 Replace the motor sensor cable (connector JYA2).	The motor cannot rotate at a specified speed. (A level not exceeding the SST level for the rotation command has existed continuously.)
SP9032	SIC-LSI RAM FAULT	32	Replace the Spindle Amplifier (SP) control printed circuit board.	Abnormality in a Spindle Amplifier (SP) control circuit component is detected. (The LSI device for serial transfer is abnormal.)

Number	Message	SP indication (*1)	Faulty location and remedy	Description
SP9033	PS PRE-CHARGE FAILURE		<ol style="list-style-type: none"> <li>1 Check and correct the power supply voltage.</li> <li>2 Replace the Power Supply (PS).</li> </ol>	<p>Charging of direct current power supply voltage in the power circuit section is insufficient when the magnetic contractor is turned on (such as open phase and defective charging resistor).</p> <p>(Power Supply alarm indication: 05)</p>
SP9034	ILLEGAL PARAMETER	34	<p>Correct a parameter value according to FANUC AC SPINDLE MOTOR <i>ai</i> series PARAMETER MANUAL (B-65280EN).</p> <p>If the parameter number is unknown, connect the spindle check board, and check the indicated parameter.</p>	Parameter data exceeding the allowable limit is set.
SP9036	OVERFLOW ERROR COUNTER	36	Check whether the position gain value is too large, and correct the value.	An error counter overflow occurred.
SP9037	ILLEGAL SETTING VELOCITY DETECTOR	37	Correct the parameter value according to FANUC AC SPINDLE MOTOR <i>ai</i> series PARAMETER MANUAL (B-65280EN).	The setting of the parameter for the number of pulses in the speed detector is incorrect.
SP9041	ILLEGAL 1REV SIGN OF POSITION CODER	41	<ol style="list-style-type: none"> <li>1 Check and correct the parameter.</li> <li>2 Replace the cable.</li> </ol>	<ol style="list-style-type: none"> <li>1 The 1-rotation signal of the spindle position coder (connector JYA3) is abnormal.</li> <li>2 Parameter setting error</li> </ol>
SP9042	NO 1REV SIGN OF POSITION CODER	42	Replace the cable.	The 1-rotation signal of the spindle position coder (connector JYA3) is disconnected.
SP9043	DISCONNECT POSITION CODER DEF. SPEED	43	Replace the cable.	The position coder signal (connector JYA3S) for differential speed in the submodule SW is abnormal.
SP9046	ILLEGAL 1REV SIGN OF SCREW CUT	46	<ol style="list-style-type: none"> <li>1 Check and correct the parameter.</li> <li>2 Replace the cable.</li> <li>3 Re-adjust the BZ sensor signal.</li> </ol>	The 1-rotation signal in threading is abnormal.
SP9047	ILLEGAL SIGNAL OF POSITION CODER	47	<ol style="list-style-type: none"> <li>1 Replace the cable.</li> <li>2 Correct the cable layout (vicinity of the power line).</li> </ol>	<p>The A/B phase signal of the spindle position coder (connector JYA3) is abnormal.</p> <p>The relationship between the A/B phase and 1-rotation signal is incorrect (Pulse count mismatch).</p>
SP9049	DEF. SPEED IS OVER VALUE	49	Check whether the calculated differential speed value exceeds the maximum motor speed.	In differential speed mode, the speed of the other spindle converted to the speed of the local spindle has exceeded the allowable limit (the differential speed is calculated by multiplying the speed of the other spindle by the gear ratio).



Number	Message	SP indication (*1)	Faulty location and remedy	Description
SP9050	SYNCHRONOUS VALUE IS OVER SPEED	50	Check whether the calculated value exceeds the maximum motor speed.	In spindle synchronization, the speed command calculation value exceeded the allowable limit (the motor speed is calculated by multiplying the specified spindle speed by the gear ratio).
SP9051	PS LOW VOLT. DC LINK		1 Check and correct the power supply voltage. 2 Replace the MC.	Input voltage drop was detected. (Power Supply alarm (PS) indication: 04) (Momentary power failure or poor MCC contact)
SP9052	ITP FAULT 1	52	1 Replace the Spindle Amplifier (SP) control printed circuit board. 2 Replace the main board or additional spindle board in the CNC.	An abnormality is detected in the interface between the CNC and spindle amplifier (the ITP signal stopped).
SP9053	ITP FAULT 2	53	1 Replace the Spindle Amplifier (SP) control printed circuit board. 2 Replace the main board or additional spindle board in the CNC.	An abnormality is detected in the interface between the CNC and spindle amplifier (the ITP signal stopped).
SP9054	OVERCURRENT	54	Review the load state.	An overload current was detected.
SP9055	ILLEGAL POWER LINE	55	1 Replace the magnetic contactor. 2 Check and correct the sequence.	The power line state signal of the magnetic contactor for spindle switching/speed range switching is abnormal.
SP9056	COOLING FAN FAILURE	56	Replace the internal cooling fan.	The internal cooling fan stopped.
SP9057	PS EXCESS-REGENERATION2		1 Decrease the acceleration/deceleration duty. 2 Check the cooling condition (peripheral temperature). 3 If the cooling fan stops, replace the resistor. 4 If the resistance is abnormal, replace the resistor.	An overload was detected in the regenerative resistance. (Power Supply alarm indication: 16) Thermostat operation or short-time overload was detected. The regenerative resistor was disconnected, or an abnormal resistance was detected.
SP9058	PS OVERLOAD		1 Check the Power Supply (PS) cooling status. 2 Replace the Power Supply (PS).	The temperature of the radiator of the Power Supply (PS) has increased abnormally. (Power Supply (PS) alarm indication: 03)
SP9059	PS INTERNAL FAN FAILURE		Replace the Power Supply (PS).	The internal cooling fan for the Power Supply (PS) stopped. (Power Supply alarm indication: 02)
SP9061	SEMI-FULL ERROR EXCESS	61	Check parameter settings.	The error between the semi-closed and full-closed sides when the dual position feedback function is used is too large.

Number	Message	SP indication (*1)	Faulty location and remedy	Description
SP9065	SERIAL SPINDLE ALARM	65	<ol style="list-style-type: none"> <li>1 Check parameter settings.</li> <li>2 Check sensor connections and signals.</li> <li>3 Check power line connections.</li> </ol>	The move distance is too long when the magnetic pole is confirmed. (synchronous spindle motor)
SP9066	COM. ERROR BETWEEN SP AMPS	66	<ol style="list-style-type: none"> <li>1 Replace the cable.</li> <li>2 Check and correct the connection.</li> </ol>	An error was found in communication (connector JX4) between Spindle Amplifiers (SP).
SP9067	FSC/EGB COMMAND ERROR	67	Check the sequence (reference position return command).	In the spindle EGB mode, reference position return was specified.
SP9069	SAFETY SPEED OVER	69	<ol style="list-style-type: none"> <li>1 Check the speed command.</li> <li>2 Check parameter settings.</li> <li>3 Check the sequence.</li> </ol>	In the state in which safety speed monitoring was enabled, the system detected that the motor speed exceeded the safety speed or detected an error during a free-run stop.
SP9070	ILLEGAL AXIS DATA	70	<ol style="list-style-type: none"> <li>1 When this alarm is issued because the configuration of the spindle amplifiers (SPs) was changed, set the spindle number for the spindle amplifier (bit 7 of parameter No. 4541 to 1 and then 0, and turn the power to the entire system off).</li> <li>2 Replace the spindle amplifier.</li> </ol>	An error was detected during transfer of spindle data of a spindle.
SP9071	SAFETY PARAMETER ERROR	71	<ol style="list-style-type: none"> <li>1 Input the safety parameter again.</li> <li>2 Replace the Spindle Amplifier (SP) control printed-circuit board.</li> </ol>	An error was detected in an axis parameter check.
SP9072	MISMATCH RESULT OF MOTOR SPEED CHECK	72	<ol style="list-style-type: none"> <li>1 Replace the Spindle Amplifier (SP) control printed-circuit board.</li> <li>2 Replace the main board or additional spindle board in the CNC.</li> </ol>	A mismatch was detected between the safety speed check results of the Spindle Amplifier (SP) and those of the CNC.
SP9073	MOTOR SENSOR DISCONNECTED	73	<ol style="list-style-type: none"> <li>1 Replace the feedback cable.</li> <li>2 Check the shield.</li> <li>3 Check and correct the connection.</li> <li>4 Adjust the sensor.</li> </ol>	The motor sensor feedback signal is not present. (connector JYA2)
SP9074	CPU TEST ERROR	74	Replace the Spindle Amplifier (SP) control printed-circuit board.	An error was detected in a CPU test.
SP9075	CRC ERROR	75	Replace the Spindle Amplifier (SP) control printed circuit board.	An error was detected in a ROM CRC test.

Number	Message	SP indication (*1)	Faulty location and remedy	Description
SP9076	INEXECUTION OF SAFETY FUNCTIONS	76	Replace the Spindle Amplifier (SP) control printed-circuit board.	The spindle amplifier (SP) detected that the safety function was not executed.
SP9077	MISMATCH RESULT OF AXIS NUMBER CHECK	77	1 Replace the Spindle Amplifier (SP) control printed-circuit board. 2 Replace the main board or additional spindle board in the CNC.	A mismatch was detected between the axis number check results of the Spindle Amplifier (SP) and those of the CNC.
SP9078	MISMATCH RESULT OF SAFETY PARAMETER CHECK	78	1 Replace the Spindle Amplifier (SP) control printed-circuit board. 2 Replace the main board or additional spindle board in the CNC.	The result of a safety parameter check by the spindle amplifier (SP) conflicts with that of a safety parameter check by the CNC.
SP9079	INITIAL TEST ERROR	79	Replace the Spindle Amplifier (SP) control printed-circuit board.	An error was detected in a initial test operation.
SP9080	ALARM AT THE OTHER SP AMP.	80	Remove the cause of the alarm of the remote Spindle Amplifier (SP).	During inter-Spindle Amplifier (SP) communication, an alarm was generated on the remote Spindle Amplifier (SP).
SP9081	1-ROT MOTOR SENSOR ERROR	81	1 Check and correct the parameter. 2 Replace the feedback cable. 3 Adjust the sensor.	The one-rotation signal of the motor sensor cannot be correctly detected. (connector JYA2)
SP9082	NO 1-ROT MOTOR SENSOR	82	1 Replace the feedback cable. 2 Adjust the sensor.	The one-rotation signal of the motor sensor is not generated. (connector JYA2)
SP9083	MOTOR SENSOR SIGNAL ERROR	83	1 Replace the feedback cable. 2 Adjust the sensor.	An irregularity was detected in a motor sensor feedback signal. (connector JYA2)
SP9084	SPNDL SENSOR DISCONNECTED	84	1 Replace the feedback cable. 2 Check the shield. 3 Check and correct the connection. 4 Check and correct the parameter. 5 Adjust the sensor.	The spindle sensor feedback signal is not present. (connector JYA4)
SP9085	1-ROT SPNDL SENSOR ERROR	85	1 Check and correct the parameter. 2 Replace the feedback cable. 3 Adjust the sensor.	The one-rotation signal of the spindle sensor cannot be correctly detected. (connector JYA4)
SP9086	NO 1-ROT SPNDL SENSOR	86	1 Replace the feedback cable. 2 Adjust the sensor.	The one-rotation signal of the spindle sensor is not generated. (connector JYA4)
SP9087	SPNDL SENSOR SIGNAL ERROR	87	1 Replace the feedback cable. 2 Adjust the sensor.	An irregularity was detected in a spindle sensor feedback signal. (connector JYA4)
SP9088	COOLING RADI FAN FAILURE	88	Replace the Spindle Amplifier radiator cooling fan.	The radiator cooling fan stopped.

Number	Message	SP indication (*1)	Faulty location and remedy	Description
SP9089	SUB MODULE SM (SSM) ERROR	89	<ol style="list-style-type: none"> <li>1 Check the connection between the Spindle Amplifier (SP) and the submodule SM (SSM).</li> <li>2 Replace the submodule SM(SSM).</li> <li>3 Replace the Spindle Amplifier (SP) control printed-circuit board.</li> </ol>	Submodule SM (SSM) error (synchronous spindle motor)
SP9090	UNEXPECTED ROTATION	90	<ol style="list-style-type: none"> <li>1 Check magnetic pole detection operation.</li> <li>2 Check whether the rotor and sensor are aligned correctly.</li> </ol>	Unexpected rotation of the synchronous spindle motor was detected.
SP9091	POLE POSITION COUNT MISS	91	Replace the motor sensor cable.	Count error of the magnetic pole position of the synchronous spindle motor
SP9092	OVER SPEED TO VELOCITY COMMAND	92	Check the sequence (whether SFR or SRV is turned on and off in the position control mode).	The motor speed exceeds the overspeed level corresponding to the velocity command.
SP9110	AMP COMMUNICATION ERROR	b0	<ol style="list-style-type: none"> <li>1 Replace the communication cable between Spindle Amplifier (SP) and Power Supply (PS).</li> <li>2 Replace the Spindle Amplifier (SP) or Power Supply (PS) control printed circuit board.</li> </ol>	Communication error between Spindle Amplifier (SP) and Power Supply (PS)
SP9111	PS LOW VOLT. CONTROL		Replace the Power Supply (PS) control printed circuit board.	Low converter control power supply voltage (Power Supply indication : 06)
SP9112	PS EXCESS-REGENERATION1		<ol style="list-style-type: none"> <li>1 Check the regenerative resistance.</li> <li>2 Check the motor selection.</li> <li>3 Replace the Power Supply (PS).</li> </ol>	Excessive converter regenerative power (Power Supply indication : 08)
SP9113	PS EXTERNAL FAN FAILURE		Replace the external radiator cooling fan for Power Supply (PS).	Stopped the external radiator cooling fan for Power Supply (PS) (Power Supply indication = 10)
SP9114	PS CONTROL AXIS ERROR 1	b4	Set parameter No. 4657 to 0.	Invalid parameter
SP9115	PS CONTROL AXIS ERROR 2	b5	Set parameter No. 4657 to other than 0.	Invalid parameter

Number	Message	SP indication (*1)	Faulty location and remedy	Description
SP9120	COMMUNICATION DATA ERROR	C0	<ol style="list-style-type: none"> <li>1 Replace the communication cable between CNC and Spindle Amplifier (SP).</li> <li>2 Replace the Spindle Amplifier (SP) control printed circuit board.</li> <li>3 Replace the main board or additional spindle board in the CNC.</li> </ol>	Communication data alarm
SP9121	COMMUNICATION DATA ERROR	C1	<ol style="list-style-type: none"> <li>1 Replace the communication cable between CNC and Spindle Amplifier (SP).</li> <li>2 Replace the Spindle Amplifier (SP) control printed circuit board.</li> <li>3 Replace the main board or additional spindle board in the CNC.</li> </ol>	Communication data alarm
SP9122	COMMUNICATION DATA ERROR	C2	<ol style="list-style-type: none"> <li>1 Replace the communication cable between CNC and Spindle Amplifier (SP).</li> <li>2 Replace the Spindle Amplifier (SP) control printed circuit board.</li> <li>3 Replace the main board or additional spindle board in the CNC.</li> </ol>	Communication data alarm
SP9123	SPINDLE SWITCH CIRCUIT ERROR	C3	Replace the submodule SW(SSW).	Submodule SW (SSW) error (spindle switching)
SP9124	LEARNING CTRL ROTATION CMD ERROR	C4	<ol style="list-style-type: none"> <li>1 Correct the velocity command.</li> <li>2 Correct the setting of the learning period parameter (No. 4425).</li> </ol>	A velocity that could not be used for learning control was specified in time-based learning control.
SP9125	LEARNING CTRL COMP ORDER ERROR	C5	Correct the settings of the parameters for the maximum and minimum orders of dynamic characteristic compensation elements for learning control (Nos. 4427 and 4428).	An order outside the allowable range was specified for dynamic characteristic compensation elements.
SP9127	LEARNING CTRL PERIOD ERROR	C7	Correct the setting of the parameter for the number of divisions per period for learning control (No. 4425).	In angle-based learning control, the reference angle period is invalid.

Number	Message	SP indication (*1)	Faulty location and remedy	Description
SP9128	SP SYNC VELOCITY ERROR EXCESS	C8	<ol style="list-style-type: none"> <li>1 Check the sequence (whether SFR or SRV is turned off or on in position control).</li> <li>2 Check and correct the load status.</li> <li>3 Check the parameter setting.</li> </ol>	In spindle synchronous control, velocity error exceeds the setting.
SP9129	SP SYNC POSITION ERROR EXCESS	C9	<ol style="list-style-type: none"> <li>1 Check the sequence (whether SFR or SRV is turned off or on in position control).</li> <li>2 Check and correct the load status.</li> <li>3 Check the parameter setting.</li> </ol>	In spindle synchronous control, position error exceeds the setting.
SP9130	TORQUE TANDEM POLARITY ERROR	d0	Check the setting of the parameter for the rotation direction (bit 2 of No. 4353).	In tandem control, the rotation directions of the master and slave motors are invalid.
SP9131	SPINDLE TUNING FUNCTION ALARM	d1	Check the message displayed by SERVO GUIDE.	Spindle tuning function alarm
SP9132	SER.SENSOR DATA ERROR	d2	<ol style="list-style-type: none"> <li>1 Replace the feedback cable.</li> <li>2 Replace the sensor.</li> <li>3 Replace the Spindle Amplifier (SP).</li> </ol>	Serial data error between a serial sensor and spindle amplifier (SP)
SP9133	SER.SENSOR TRANSFER ERROR	d3	<ol style="list-style-type: none"> <li>1 Replace the feedback cable.</li> <li>2 Replace the sensor.</li> <li>3 Replace the Spindle Amplifier (SP).</li> </ol>	Serial data error between a serial sensor and spindle amplifier (SP)
SP9134	SER.SENSOR SOFT PHASE ERROR	d4	<ol style="list-style-type: none"> <li>1 Check and correct the sensor parameter setting.</li> <li>2 Take action against noise.</li> <li>3 Replace the sensor.</li> </ol>	The change in serial sensor positional data is too large.
SP9135	SAFETY SPEED ZERO ERROR(SP)	d5	Perform operation within the safety speed zero range.	The motor position exceeded the safety speed zero monitoring width.
SP9136	MISMATCH RESULT OF SAFETY SPEED ZERO CHECK(SP)	d6	Replace the Spindle Amplifier (SP) control printed circuit board.	The Spindle Amplifier (SP) speed zero determination result did not match the CNC speed zero determination result.
SP9137	SP DEVICE COMMUNICATION ERROR	d7	Replace the Spindle Amplifier (SP) control printed circuit board.	Device communication error in the spindle amplifier (SP)
SP9138	CURRENT LIMIT SETTING ERROR	d8	Check the parameter.	The current limit level setting is out of the specified range.
SP9139	SER.SENSOR PULSE MISS	d9	Replace the sensor.	An error occurred in the serial sensor interpolation circuit.

Number	Message	SP indication (*1)	Faulty location and remedy	Description
SP9140	SER.SENSOR COUNT MISS	E0	1 Take action against noise. 2 Replace the sensor.	The number of feedback pulses per one-rotation signal of the serial sensor is outside the specified range.
SP9141	SER.SENSOR NO 1-ROT SIGNAL	E1	1 Check and correct the sensor parameter setting. 2 Replace the sensor.	The serial sensor is not placed in the status in which the one-rotation signal has been detected.
SP9142	SER.SENSOR ABNORMAL	E2	Replace the sensor.	A serial sensor error occurred.
SP9143	CS HIGH SPEED CHANGE CMD ERROR	E3	Check the sequence.	A command was issued though the one-rotation signal had not been detected.
SP9144	CURRENT DETECT CIRCUIT ERROR	E4	Replace the Spindle Amplifier (SP).	An error was found in the current detection circuit.
SP9145	LOW VOLTAGE DRIVER	E5	Replace the Spindle Amplifier (SP).	The driver circuit voltage has dropped.
SP9146	SP:INTERNAL OVERHEAT	E6	1 Check that the temperature in the power magnetics cabinet is within the specification range. 2 If this alarm is issued immediately after power-on, replace the spindle amplifier (SP).	The internal temperature of the spindle amplifier (SP) exceeds the specified value.
SP9147	SP:GROUND FAULT	E7	Replace the motor or amplifier.	A ground fault occurred in the motor or amplifier.
SP9200	PS GROUND FAULT		Replace the motor or amplifier.	A ground fault occurred in the motor or amplifier. (Power Supply (PS) alarm indication: 09)
SP9201	PS OVERCURRENT 2		Replace the Power Supply (PS).	Overcurrent was detected in the main circuit input in the power supply (PS). (Power Supply (PS) alarm indication: 11)
SP9202	PS OVERCURRENT 3		Replace the Power Supply (PS).	Overcurrent was detected in the main circuit input in the power supply (PS). (Power Supply (PS) alarm indication: 12)
SP9203	PS OVERCURRENT 4		Replace the Power Supply (PS).	Overcurrent was detected in the main circuit input in the power supply (PS). (Power Supply (PS) alarm indication: 13)
SP9204	PS SOFT THERMAL		Review the current condition.	Overload was detected in the power supply (PS). (Power Supply (PS) alarm indication: 15)

Number	Message	SP indication (*1)	Faulty location and remedy	Description
SP9205	PS OVER VOLT. DC LINK 2		Replace the Power Supply (PS).	Overvoltage was detected in the DC link section. (Power Supply (PS) alarm indication: 17)
SP9206	PS OVER VOLT. DC LINK 3		Replace the Power Supply (PS).	Overvoltage was detected in the DC link section. (Power Supply (PS) alarm indication: 18)
SP9207	PS OVER VOLT. DC LINK 4		Replace the Power Supply (PS).	Overvoltage was detected in the DC link section. (Power Supply (PS) alarm indication: 19)
SP9208	PS LOW VOLT.DC LINK2		Replace the Power Supply (PS).	Voltage drop was detected in the DC link section. (Power Supply (PS) alarm indication: 20)
SP9209	PS LOW VOLT.DC LINK3		Replace the Power Supply (PS).	Voltage drop was detected in the DC link section. (Common Power Supply (PS) alarm indication: 21)
SP9210	PS LOW VOLT.DC LINK4		Replace the Power Supply (PS).	Voltage drop was detected in the DC link section. (Power Supply (PS) alarm indication: 22)
SP9211	PS ILLEGAL PARAMETER		Change the parameter to an appropriate value.	An invalid value was set in a parameter for controlling the power supply (PS). (Power Supply (PS) alarm indication: 23)
SP9212	PS HARDWARE ERROR		Replace the Power Supply (PS).	A hardware error was detected in the power supply (PS). (Power Supply (PS) alarm indication: 24)



## A.4 ERROR CODES (SERIAL SPINDLE)

### NOTE

\*1 Note that the meanings of the Spindle Amplifier (SP) indications differ depending on which LED, the red or yellow LED, is on. When the yellow LED is on, an error code is indicated with a 2-digit number. An error code is indicated in the CNC diagnosis data No.710. When the red LED is on, the Spindle Amplifier (SP) indicates the number of an alarm generated in the serial spindle.  
→ See Section, "ALARM LIST (SERIAL SPINDLE)."

SP indication (*1)	Description	Faulty section and action
01	Although neither *ESP (emergency stop signal; there are two types of signals including the input signal and Power Supply (PS) contact signal) nor MRDY (machine ready signal) is input, SFR (forward rotation signal)/SRF (reverse rotation signal)/ORCM (orientation command) is input.	Check the *ESP and MRDY sequence. For MRDY, pay attention to the parameter setting regarding the use of the MRDY signal (bit 0 of parameter No. 4001).
03	The parameter settings are such that a position sensor is not used (position control not performed) (bits 3, 2, 1, 0 of parameter No. 4002 = 0, 0, 0, 0), but a Cs contour control command is input. In this case, the motor is not excited.	Check the parameter settings.
04	The parameter settings are such that a position sensor is not used (position control not performed) (bits 3, 2, 1, 0 of parameter No.4002 = 0, 0, 0, 0), but a servo mode (rigid tapping, spindle positioning, etc.) or spindle synchronization command is input. In this case, the motor is not excited.	Check the parameter settings.
05	The orientation function option parameter is not specified, but ORCM (orientation command) is input.	Check the orientation function parameter settings.
06	The speed range switching control function option parameter is not specified, but low-speed characteristic winding is selected (RCH = 1).	Check the speed range switching control function parameter settings and the power line state check signal (RCH).
07	A Cs contour control command is input, but SFR (forward rotation command)/SRV (reverse rotation command) is not input.	Check the sequence.
08	A servo mode (rigid tapping, spindle positioning, etc.) control command is input, but SFR (forward rotation command)/SRV (reverse rotation command) is not input.	Check the sequence.
09	A spindle synchronization command is input, but SFR (forward rotation command)/SRV (reverse rotation command) is not input.	Check the sequence.
10	A Cs contour control command is input, but another mode (servo mode, spindle synchronization or orientation) is specified.	Do not switch to another mode during a Cs contour control command. Before moving to another mode, cancel the Cs contour control command.
11	A servo mode (rigid tapping, spindle positioning, etc.) command is input, but another mode (Cs contour control, spindle synchronization or orientation) is specified.	Do not switch to another mode during a servo mode command. Before moving to another mode, cancel the servo mode command.

SP indication (*1)	Description	Faulty section and action
12	A spindle synchronization command is input, but another mode (Cs contour control, servo mode or orientation) is specified.	Do not switch to another mode during a spindle synchronization command. Before moving to another mode, cancel the spindle synchronization command.
13	An orientation command is input, but another mode (Cs contour control, servo mode or spindle synchronization control) is specified.	Do not switch to another mode during an orientation command. Before moving to another mode, cancel the orientation command.
14	Both SFR (forward rotation command) and SRV (reverse rotation command) are input at the same time.	Issue either of them.
16	The parameter settings are such that the differential speed control function is not used (bit 5 of parameter No. 4000 = 0), but DEFMD (differential speed mode command) is input.	Check the parameter settings and differential speed mode command.
17	The speed detector parameter settings (bits 2, 1, and 0 of parameter No. 4011) are not valid. There is no corresponding speed detector.	Check the parameter settings.
18	The parameter settings are such that a position sensor is not used (position control not performed (bits 3, 2, 1, and 0 of parameter No. 4002), but position coder system orientation is issued.	Check the parameter settings and the input signal.
19	The magnetic sensor orientation command is input, but another mode (Cs contour control, servo mode or spindle synchronization control) is specified.	Do not switch to another mode during an orientation command. Before moving to another mode, cancel the orientation command.
21	The tandem operation command was input in the spindle synchronization control enable state.	Input the tandem operation command when spindle synchronization control is canceled.
22	Spindle synchronization control was specified in the tandem operation enable state.	Specify spindle synchronization control when torque tandem operation is canceled.
23	The tandem operation command is input without the required option.	Torque tandem control requires a CNC software option. Check the option.
24	If index is performed continuously in position coder method orientation, an incremental operation is performed first (INCMD = 1), then an absolute position command (INCMD = 0) is input.	Check INCMD (incremental command). If an absolute position command is to follow, be sure to perform absolute position command orientation first.
26	The parameter settings are such that both spindle switch and three-stage speed range switch are used.	Check the parameter settings and the input signal.
29	The parameter settings are such that the shortest-time orientation function is used (bit 6 of parameter No. 4018 = 0, Nos. 4320 to 4323 ≠ 0).	In the $\alpha$ i series spindle amplifier, the shortest-time orientation function cannot be used. The use of the optimum orientation function is recommended.
30	The magnetic pole has not been detected, but a command is input.	In the magnetic pole undetected state (EPFIXA = 0), the motor cannot be driven even when a command is input. Input a command in the magnetic pole detected state (EPFIXA = 1). When EPFSTR is set to 1, any command is ignored and this error is displayed even in the magnetic pole detected state. After the completion of magnetic pole detection, set EPFSTR to 0.
31	The hardware configuration is such that the spindle FAD function cannot be used. In this case, the motor is not activated.	Check the CNC model. With the FS30i series, the spindle FAD function is not used.

SP indication (*1)	Description	Faulty section and action
32	S0 is not specified in the velocity mode, but the disturbance input function is enabled (bit 7 of parameter No. 4395 is set to 1).	Specify S0 in the velocity mode before enabling the disturbance input function (bit 7 of parameter No. 4395 to 1).
33	The hardware configuration is such that the spindle EGB function cannot be used. In this case, the motor is not activated.	Check the CNC model.
34	Both the spindle FAD function and the spindle EGB function are enabled. In this case, the motor is not activated.	The two functions cannot be used at the same time. Enable either function only.
35	Spindle Amplifier (SP) ID information cannot be obtained.	Replace the spindle amplifier with one with correct ID information.
36	The submodule SM (SSM) is faulty .	For action to be taken, refer to the FANUC AC SPINDLE MOTOR <i>αi</i> series PARAMETER MANUAL (B-65280EN).
37	The current loop setting (No. 4012) has been changed.	Check the setting of parameter No. 4012, and turn the power off, then on again.
38	A parameter related to communication between spindle amplifiers is specified incorrectly. Alternatively, a function unavailable with the torque tandem function is set.	Check the parameters.
39	Although SFR (forward rotation command), SRV (reverse rotation command), or ORCM (orientation command) is input, DSCN (disconnection detection disable signal) is input.	Check the sequence. Do not input DSCN (disconnection detection disable signal) during the input of a command which excites the motor.
43	A setting which does not support the <i>αi</i> CZ sensor (serial) is used.	Check the parameter settings.
44	The spindle amplifier does not support the control period setting.	Check the setting of parameter No. 4012.

# B LISTS OF UNITS, PRINTED CIRCUIT BOARDS, AND CONSUMABLES

## B.1 UNITS AND PRINTED CIRCUIT BOARDS FOR LCD-MOUNTED TYPE CONTROL UNIT

### NOTE

Read Section B.4 first for information on units with personal computer functions with Windows<sup>®</sup>CE, because some of the printed circuit boards and units used with them are unique.

### Case

Item	Specification	Remark
Case unit: no slot	A02B-0323-C510	*1
Case unit: 1 slot	A02B-0323-C511	*1
Case unit: 2 slots	A02B-0323-C512	*1
Case for no-slot basic unit	A02B-0323-D100#0A	
Case for 1-slot basic unit	A02B-0323-D100#1A	
Case for 2-slot basic unit	A02B-0323-D100#2A	

\*1 The case unit includes the case, fan motor, and battery.

### LCD unit

Item	Specification	ID	Remark
8.4"LCD unit	A02B-0323-D503	–	
8.4"LCD unit (with protection cover)	A02B-0323-D575	–	
10.4"LCD unit A	A02B-0323-D500	–	
10.4"LCD unit A (with protection cover)	A02B-0323-D574	–	
10.4"LCD unit A (with touch panel)	A02B-0323-D570	–	*2
10.4"LCD unit A (with touch panel and protection cover)	A02B-0323-D572	–	
10.4"LCD unit B	A02B-0323-D505	0111	
10.4"LCD unit B (with touch panel)	A02B-0323-D507	0111	*2
10.4"LCD unit B (with protection cover)	A02B-0323-D525	0111	
10.4"LCD unit B (with touch panel and protection cover)	A02B-0323-D527	0111	*2
15"LCD unit	A02B-0323-D515	0101	
15"LCD unit (with touch panel)	A02B-0323-D517	0101	*2
15"LCD unit (with protection cover)	A02B-0323-D535	0101	
15"LCD unit (with touch panel and protection cover)	A02B-0323-D537	0101	*2

\*2 Used in combination with the touch panel control board A20B-8002-0312.

### Printed circuit boards

Item	Specification	ID	Remark
Main board A1	A20B-8200-0720	00338	
Main board A2	A20B-8200-0721	00339	
Main board A4	A20B-8200-0723	0033B	
Main board A5	A20B-8200-0724	0033C	
Main board B5	A20B-8200-0718	0034E	
Main board B7	A20B-8200-0708	0034C	
Main board B5	A20B-8200-0718	0034E	
Main board B7	A20B-8200-0708	0034C	

Item	Specification	ID	Remark
Main board B6	A20B-8200-0719	0034F	
Main board B8	A20B-8200-0709	0034D	
Main board B6	A20B-8200-0719	0034F	
Main board B8	A20B-8200-0709	0034D	
Main board B1	A20B-8200-0712	00352	
Main board B3	A20B-8200-0702	00342	
Main board B1	A20B-8200-0712	00352	
Main board B3	A20B-8200-0702	00342	
Main board B2	A20B-8200-0716	00356	
Main board B4	A20B-8200-0706	00346	
Main board B2	A20B-8200-0716	00356	
Main board B4	A20B-8200-0706	00346	
Back panel (no slot, with power supply)	A20B-8200-0650	01	
Back panel (1 slot, with power supply)	A20B-8200-0670	00	
Back panel (2 slots, with power supply)	A20B-8200-0680	10	
Inverter board (for 8.4" LCD unit)	A20B-8200-0663	1011	
Inverter board (for 10.4" LCD unit)	A20B-8200-0662	1010	
Inverter board (for 15" LCD unit)	A14L-0168-0001	–	
Touch panel control board	A20B-8002-0312	–	
Fan adapter board (for 15" LCD unit)	A20B-8200-0669	–	

### Others

Item	Specification	Remark
Compact flash card	A02B-0323-C990#A	
Connection cable between main board and inverter board	A660-4042-T076#L75R00	For 15" LCD unit

## B.2 UNITS AND PRINTED CIRCUIT BOARDS FOR STAND-ALONTE TYPE CONTROL UNIT

### NOTE

Read Section B.4 first for information on units with personal computer functions with Windows<sup>®</sup>CE, because some of the printed circuit boards and units used with them are unique.

### Fan unit

Item	Specification	Remark
Fan unit for 2 slots	A02B-0303-C103	With fan motor
Fan unit for 4 slots	A02B-0303-C102	With fan motor

### Printed circuit board

Item	Specification	ID	Remark
Main board D1	A16B-3200-0710	00348	
Main board D2	A16B-3200-0711	00349	
Back panel: 2 slots	A20B-2003-0580	01	
Back panel: 4 slots	A20B-2003-0650	10	
Fan connection unit	A20B-9002-0350	–	
Power supply unit	A20B-8101-0011	–	

**Display unit**

**- Display unit with 10.4" LCD unit A**

Item	Name	Specification	Remark
Display unit A02B-0323-C074	Display control board	A20B-8200-0760	ID=00620
	Inverter board (for 10.4" LCD unit)	A20B-8200-0662	ID=1010
	10.4"LCD unit A	A02B-0323-D500	
Display unit (with protection cover) A02B-0323-C075	Display control board	A20B-8200-0760	ID=00620
	Inverter board (for 10.4" LCD unit)	A20B-8200-0662	ID=1010
	10.4"LCD unit A (with protection cover)	A02B-0323-D574	
Display unit (with touch panel) A02B-0323-C084	Display control board	A20B-8200-0760	ID=00620
	Inverter board (for 10.4" LCD unit)	A20B-8200-0662	ID=1010
	Touch panel control board	A20B-8002-0312	
	Touch panel cable	A660-2042-T145#L200R0	
	10.4"LCD unit A (with touch panel)	A02B-0323-D570	
Display unit (with touch panel and protection cover) A02B-0323-C085	Display control board	A20B-8200-0760	ID=00620
	Inverter board (for 10.4" LCD unit)	A20B-8200-0662	
	10.4"LCD unit A (with touch panel and protection cover)	A02B-0323-D572	
First LCD unit for 2-display unit A02B-0323-C072	Display control board	A20B-8200-0761	ID=00621
	Inverter board (for 10.4" LCD unit)	A20B-8200-0662	ID=1010
	10.4"LCD unit A	A02B-0323-D500	
First LCD unit for 2-display unit (with protection cover) A02B-0323-C076	Display control board	A20B-8200-0761	ID=00621
	Inverter board (for 10.4" LCD unit)	A20B-8200-0662	ID=1010
	10.4"LCD unit A (with protection cover)	A02B-0323-D574	
Second LCD unit for 2-display unit A02B-0323-C073	Display control board	A20B-8200-0762	
	Inverter board (for 10.4" LCD unit)	A20B-8200-0662	ID=1010
	10.4"LCD unit A (as the second LCD unit for 2-display unit)	A02B-0323-D521	
Second LCD unit for 2-display unit (with protection cover) A02B-0323-C077	Display control board	A20B-8200-0762	
	Inverter board (for 10.4" LCD unit)	A20B-8200-0662	ID=1010
	10.4"LCD unit A (as the second LCD unit for 2-display unit, with protection cover)	A02B-0323-D576	

**- Display unit with 10.4"LCD unit B**

Item	Name	Specification	Remark
Display unit A02B-0323-C078	Display control board	A20B-8200-0746	
	Compact flash card	A02B-0323-C990#A	
	Inverter board	A20B-8200-0662	
	10.4"LCD unit B	A02B-0323-D540	ID=0111
	Power supply unit	A20B-8101-0011	
Display unit (with touch panel) A02B-0323-C079	Display control board	A20B-8200-0746	
	Compact flash card	A02B-0323-C990#A	
	Inverter board	A20B-8200-0662	
	10.4"LCD unit B (with touch panel)	A02B-0323-D542	ID=0111
	Power supply unit	A20B-8101-0011	
Display unit (with protection cover) A02B-0323-C088	Display control board	A20B-8200-0746	
	Compact flash card	A02B-0323-C990#A	
	Inverter board	A20B-8200-0662	
	10.4"LCD unit B (with protection cover)	A02B-0323-D550	ID=0111
	Power supply unit	A20B-8101-0011	

Item	Name	Specification	Remark
Display unit (with touch panel and protection cover) A02B-0323-C089	Display control board	A20B-8200-0746	
	Compact flash card	A02B-0323-C990#A	
	Inverter board	A20B-8200-0662	
	10.4"LCD unit B (with touch panel and protection cover)	A02B-0323-D552	ID=0111
	Power supply unit	A20B-8101-0011	

**- Display unit with 15"LCD unit**

Item	Name	Specification	Remark
Display unit A02B-0323-C091	Display control board	A20B-8200-0742	
	Compact flash card	A02B-0323-C990#A	Including software
	Power supply unit	A20B-8101-0011	
	Inverter board	A14L-0168-0001	
	Connection cable between display control board and inverter board	A660-4042-T076#L75R00	
	Fan adapter board	A20B-8200-0669	
	15"LCD unit	A02B-0323-D546	ID=0101
Display unit (with touch panel) A02B-0323-C092	Display control board	A20B-8200-0742	
	Compact flash card	A02B-0323-C990#A	Including software
	Power supply unit	A20B-8101-0011	
	Inverter board	A14L-0168-0001	
	Connection cable between display control board and inverter board	A660-4042-T076#L75R00	
	Fan adapter board	A20B-8200-0669	
	15"LCD unit (with touch panel)	A02B-0323-D548	ID=0101
Display unit (with protection cover) A02B-0323-C095	Display control board	A20B-8200-0742	
	Compact flash card	A02B-0323-C990#A	Including software
	Power supply unit	A20B-8101-0011	
	Inverter board	A14L-0168-0001	
	Connection cable between display control board and inverter board	A660-4042-T076#L75R00	
	Fan adapter board	A20B-8200-0669	
	15"LCD unit (with protection cover)	A20B-0323-D556	ID=0101
Display unit (with touch panel and protection cover) A02B-0323-C096	Display control board	A20B-8200-0742	
	Compact flash card	A02B-0323-C990#A	Including software
	Power supply unit	A20B-8101-0011	
	Inverter board	A14L-0168-0001	
	Connection cable between display control board and inverter board	A660-4042-T076#L75R00	
	Fan adapter board	A20B-8200-0669	
	15"LCD unit (with touch panel and protection cover)	A20B-0323-D558	ID=0101

B. LISTS OF UNITS, PRINTED CIRCUIT  
BOARDS, AND CONSUMABLES APPENDIX

B-64485EN/01

- Display unit for automotive manufacture

Item	Name	Specification	Remark
15" display unit A13B-0201-B201	Display control board	A20B-8200-0745	
	Compact flash card	A02B-0323-C990#B	Including software
	Power supply unit	A20B-8101-0011	
	Inverter board	A14L-0168-0001	
	Connection cable between display control board and inverter board	A660-4042-T076#L75R00	
	Fan adapter board	A20B-8200-0669	
	LCD unit	A13B-0201-D201	ID=0101
15" display unit (with touch panel) A13B-0201-B202	Display control board	A20B-8200-0745	
	Compact flash card	A02B-0323-C990#B	Including software
	Power supply unit	A20B-8101-0011	
	Inverter board	A14L-0168-0001	
	Connection cable between display control board and inverter board	A660-4042-T076#L75R00	
	Fan adapter board	A20B-8200-0669	
	LCD unit (with touch panel)	A13B-0201-D202	ID=0101
15" display unit (with protection cover) A13B-0201-B203	Display control board	A20B-8200-0745	
	Compact flash card	A02B-0323-C990#B	Including software
	Power supply unit	A20B-8101-0011	
	Inverter board	A14L-0168-0001	
	Connection cable between display control board and inverter board	A660-4042-T076#L75R00	
	Fan adapter board	A20B-8200-0669	
	LCD unit (with protection cover)	A13B-0201-D203	ID=0101
15" display unit (with touch panel and protection cover) A13B-0201-B204	Display control board	A20B-8200-0745	
	Compact flash card	A02B-0323-C990#B	Including software
	Power supply unit	A20B-8101-0011	
	Inverter board	A14L-0168-0001	
	Connection cable between display control board and inverter board	A660-4042-T076#L75R00	
	Fan adapter board	A20B-8200-0669	
	LCD unit (with touch panel and protection cover)	A13B-0201-D204	ID=0101
15" display unit (with I/O Link) A13B-0201-B211	Display control board	A20B-8200-0745	
	Compact flash card	A02B-0323-C990#B	Including software
	Power supply unit	A20B-8101-0011	
	Inverter board	A14L-0168-0001	
	Connection cable between display control board and inverter board	A660-4042-T076#L75R00	
	Fan adapter board	A20B-8200-0669	
	I/O Link adapter board	A20B-8002-0500	
	DC power cable	A660-2005-T779#160R0	
LCD unit	A13B-0201-D211	ID=0101	



Item	Name	Specification	Remark
15" display unit (with touch panel and I/O Link) A13B-0201-B212	Display control board	A20B-8200-0745	
	Compact flash card	A02B-0323-C990#B	Including software
	Power supply unit	A20B-8101-0011	
	Inverter board	A14L-0168-0001	
	Connection cable between display control board and inverter board	A660-4042-T076#L75R00	
	Fan adapter board	A20B-8200-0669	
	I/O Link adapter board	A20B-8002-0500	
	DC power cable	A660-2005-T779#160R0	
	LCD unit (with touch panel)	A13B-0201-D212	ID=0101
15" display unit (with I/O Link and protection cover) A13B-0201-B213	Display control board	A20B-8200-0745	
	Compact flash card	A02B-0323-C990#B	Including software
	Power supply unit	A20B-8101-0011	
	Inverter board	A14L-0168-0001	
	Connection cable between display control board and inverter board	A660-4042-T076#L75R00	
	Fan adapter board	A20B-8200-0669	
	I/O Link adapter board	A20B-8002-0500	
	DC power cable	A660-2005-T779#160R0	
	LCD unit (with protection cover)	A13B-0201-D213	ID=0101
15" display unit (with touch panel, I/O Link, and protection cover) A13B-0201-B214	Display control board	A20B-8200-0745	
	Compact flash card	A02B-0323-C990#B	Including software
	Power supply unit	A20B-8101-0011	
	Inverter board	A14L-0168-0001	
	Connection cable between display control board and inverter board	A660-4042-T076#L75R00	
	Fan adapter board	A20B-8200-0669	
	I/O Link adapter board	A20B-8002-0500	
	DC power cable	A660-2005-T779#160R0	
	LCD unit (with touch panel and protection cover)	A13B-0201-D214	ID=0101

### B.3 PRINTED CIRCUIT BOARDS COMMON TO LCD-MOUNTED AND STAND-ALONE TYPE CONTROL UNITS

Item	Specification	ID	Remark
CPU card A1	A20B-3300-0652	00442	
CPU card A2	A20B-3300-0653	00443	
CPU card B1	A20B-3300-0650	00440	
CPU card B2	A20B-3300-0651	00441	
CPU card C1	A20B-3300-0654	00444	
CPU card C2	A20B-3300-0655	00445	
Servo card A11	A20B-3300-0664	00155	
Servo card A12	A20B-3300-0663	00154	
Servo card A13	A20B-3300-0662	00153	
Servo card A24	A20B-3300-0661	00152	
Servo card A26	A20B-3300-0660	00151	
FROM/SRAM module O	A02B-3900-0250	FROM: D4, SRAM: 03	
FROM/SRAM module P	A02B-3900-0251	FROM: D4, SRAM: 04	

Item	Specification	ID	Remark
FROM/SRAM module M	A02B-3900-0252	FROM: D3, SRAM: 03	
FROM/SRAM module R	A20B-3900-0260	FROM: D4, SRAM: 06	For personal computer function with Windows® CE
GUI card (DDR SDRAM 128MB)	A20B-3300-0670	1110	
Additional axis board	A20B-8101-0740	00161	
HSSB interface board	A20B-8101-0111	00611	
Fast Ethernet board	A20B-8101-0770	0070E	
PROFIBUS-DP master board	A20B-8101-0050	00704	
PROFIBUS-DP slave board	A20B-8101-0100	00705	
DeviceNet master board	A20B-8101-0220	00706	
DeviceNet slave board	A20B-8101-0330	00708	
CC-Link remote device station board	A20B-8101-0551	—	

## B.4 PRINTED CIRCUIT BOARDS AND UNITS UNIQUE TO PERSONAL COMPUTER FUNCTION WITH Windows® CE

### B.4.1 Personal computer function with Windows® CE for LCD-mounted type Control Unit

#### List of printed circuit boards

Item	Specification	ID	Remark
Main board C1	A20B-8200-0710	00350	
Main board C7	A20B-8200-0700	00340	
Main board C4	A20B-8200-0714	00354	
Main board C10	A20B-8200-0704	00344	
Main board C3	A20B-8200-0713	00353	
Main board C9	A20B-8200-0703	00343	
Main board C6	A20B-8200-0717	00357	
Main board C12	A20B-8200-0707	00347	
Main board C2	A20B-8200-0711	00351	
Main board C8	A20B-8200-0701	00341	
Main board C5	A20B-8200-0715	00355	
Main board C11	A20B-8200-0705	00345	
GUI card (DDR SDRAM 256MB)	A20B-3300-0671	1111	See Section B.3 for descriptions of the GUI card (DDR SDRAM 128MB).
Inverter board (for 12.1" LCD unit)	A14L-0143-0003	—	See Section B.1 for descriptions of the inverter board for the 10.4" and 15" LCD units.
Fan adapter board (for 12.1" or 15" LCD unit)	A20B-8200-0669	—	

#### List of units

Item	Specification	ID	Remark
10.4" LCD unit	A02B-0323-D505	1111	
10.4" LCD unit (with touch panel)	A02B-0323-D507	1111	
10.4" LCD unit (with protection cover)	A02B-0323-D525	1111	
10.4" LCD unit (with touch panel and protection cover)	A02B-0323-D527	1111	
12.1" LCD unit	A02B-0323-D508	1110	
12.1" LCD unit (with touch panel)	A02B-0323-D510	1110	
12.1" LCD unit (with protection cover)	A02B-0323-D528	1110	

Item	Specification	ID	Remark
12.1" LCD unit (with touch panel and protection cover)	A02B-0323-D530	1110	
15" LCD unit	A02B-0323-D515	1101	
15" LCD unit (with touch panel)	A02B-0323-D517	1101	
15" LCD unit (with protection cover)	A02B-0323-D535	1101	
15" LCD unit (with touch panel and protection cover)	A02B-0323-D537	1101	

### Compact flash cards on printed circuit boards

Item	Specification	Remark
Compact flash card	A87L-0001-0173#128MBD	Total capacity: 128MB
	A87L-0001-0173#256MBD	Total capacity: 256MB
	A87L-0001-0173#512MBD	Total capacity: 512MB
	A87L-0001-0173#001GBD	Total capacity: 1GB
	A87L-0001-0173#002GBD	Total capacity: 2GB

### Backup unit

Item	Specification	Remark
Backup unit	A20B-2100-0820	For installation on the rear of the MDI unit
		For installation inside a cabinet.
		For installation on the rear of the MDI unit (QWRTY TYPE B)
Cable for backup unit	A660-4042-T078#L500R0A	

### Others

Item	Specification	Remark
Connection cable between main board and inverter board	A660-4042-0075#L90R00	For 12.1" LCD unit
	A660-4042-0076#L75R00	For 15" LCD unit

## B.4.2 Personal computer function with Windows<sup>®</sup> CE for Stand-alone type Control Unit

### Display unit

#### · Display unit with 10.4" LCD unit

Item	Name	Specification	Remark
Display unit A13B-0201-B001	Display control board	A20B-8200-0740	
	Power supply unit	A20B-8101-0011	
	Inverter board	A20B-8200-0662	
	10.4"LCD unit	A02B-0323-D540	ID=1111
	Case	A02B-0323-D100#0A	
Display unit (with touch panel) A13B-0201-B003	Display control board	A20B-8200-0740	
	Power supply unit	A20B-8101-0011	
	Inverter board	A20B-8200-0662	
	10.4"LCD unit (with touch panel)	A02B-0323-D542	ID=1111
	Case	A02B-0323-D100#0A	
Display unit (with protection cover) A13B-0201-B004	Display control board	A20B-8200-0740	
	Power supply unit	A20B-8101-0011	
	Inverter board	A20B-8200-0662	
	10.4"LCD unit (with protection cover)	A02B-0323-D550	ID=1111
	Case	A02B-0323-D100#0A	

B. LISTS OF UNITS, PRINTED CIRCUIT  
BOARDS, AND CONSUMABLES APPENDIX

B-64485EN/01

Item	Name	Specification	Remark
Display unit (with touch panel and protection cover) A13B-0201-B006	Display control board	A20B-8200-0740	
	Power supply unit	A20B-8101-0011	
	Inverter board	A20B-8200-0662	
	10.4"LCD unit (with touch panel and protection cover)	A02B-0323-D552	ID=1111
	Case	A02B-0323-D100#0A	

- Display unit with 12.1" LCD unit

Item	Name	Specification	Remark
Display unit A13B-0201-B011	Display control board	A20B-8200-0743	
	Power supply unit	A20B-8101-0011	
	Inverter board	A14L-0143-0003	
	Connection cable between display control board and inverter board	A660-4042-T075#L90R00	
	Fan adapter board	A20B-8200-0669	
	12.1"LCD unit	A02B-0323-D543	ID=1110
	Case	A02B-0323-D100#0A	
Display unit (with touch panel) A13B-0201-B013	Display control board	A20B-8200-0743	
	Power supply unit	A20B-8101-0011	
	Inverter board	A14L-0143-0003	
	Connection cable between display control board and inverter board	A660-4042-T075#L90R00	
	Fan adapter board	A20B-8200-0669	
	12.1"LCD unit (with touch panel)	A02B-0323-D545	ID=1110
	Case	A02B-0323-D100#0A	
Display unit (with protection cover) A13B-0201-B014	Display control board	A20B-8200-0743	
	Power supply unit	A20B-8101-0011	
	Inverter board	A14L-0143-0003	
	Connection cable between display control board and inverter board	A660-4042-T075#L90R00	
	Fan adapter board	A20B-8200-0669	
	12.1"LCD unit (with protection cover)	A02B-0323-D553	ID=1110
	Case	A02B-0323-D100#0A	
Display unit (with touch panel and protection cover) A13B-0201-B016	Display control board	A20B-8200-0743	
	Power supply unit	A20B-8101-0011	
	Inverter board	A14L-0143-0003	
	Connection cable between display control board and inverter board	A660-4042-T075#L90R00	
	Fan adapter board	A20B-8200-0669	
	12.1"LCD unit (with touch panel and protection cover)	A02B-0323-D555	ID=1110
	Case	A02B-0323-D100#0A	

· **Display unit with 15" LCD unit**

Item	Name	Specification	Remark
Display unit A13B-0201-B021	Display control board	A20B-8200-0741	
	Power supply unit	A20B-8101-0011	
	Inverter board	A14L-0168-0001	
	Connection cable between display control board and inverter board	A660-4042-T076#L75R00	
	Fan adapter board	A20B-8200-0669	
	15"LCD unit	A02B-0323-D546	ID=1101
	Case	A02B-0323-D100#0A	
Display unit (with touch panel) A13B-0201-B023	Display control board	A20B-8200-0741	
	Power supply unit	A20B-8101-0011	
	Inverter board	A14L-0168-0001	
	Connection cable between display control board and inverter board	A660-4042-T076#L75R00	
	Fan adapter board	A20B-8200-0669	
	15"LCD unit (with touch panel)	A02B-0323-D548	ID=1101
	Case	A02B-0323-D100#0A	
Display unit (with protection cover) A13B-0201-B024	Display control board	A20B-8200-0741	
	Power supply unit	A20B-8101-0011	
	Inverter board	A14L-0168-0001	
	Connection cable between display control board and inverter board	A660-4042-T076#L75R00	
	Fan adapter board	A20B-8200-0669	
	15"LCD unit (with protection cover)	A02B-0323-D556	ID=1101
	Case	A02B-0323-D100#0A	
Display unit (with touch panel and protection cover) A13B-0201-B026	Display control board	A20B-8200-0741	
	Power supply unit	A20B-8101-0011	
	Inverter board	A14L-0168-0001	
	Connection cable between display control board and inverter board	A660-4042-T076#L75R00	
	Fan adapter board	A20B-8200-0669	
	15"LCD unit (with touch panel and protection cover)	A02B-0323-D558	ID=1101
	Case	A02B-0323-D100#0A	

**GUI card**

Item	Specification	Remark
GUI カード(DDR SDRAM 256MB)	A20B-3300-0671	ID=1111

\* See Section B.3 for descriptions of the GUI card (DDR SDRAM 128MB).

**Compact flash cards on printed circuit boards**

Item	Specification	Remark
Compact flash card	A87L-0001-0173#128MBD	Total capacity: 128MB
	A87L-0001-0173#256MBD	Total capacity: 256MB
	A87L-0001-0173#512MBD	Total capacity: 512MB
	A87L-0001-0173#001GBD	Total capacity: 1GB
	A87L-0001-0173#002GBD	Total capacity: 2GB

### Backup unit

Item	Specification	Remark
Backup unit	A02B-0303-H160	For installation on the rear of the MDI unit
	A02B-0303-C161	For installation inside a cabinet.
	A02B-0303-H164	For installation on the rear of the MDI unit (QWRTY TYPE B)
Cable for backup unit	A02B-0323-K801	

## B.5 MDI UNIT

Item	Specification	ID	Remark
Small MDI unit (for lathe system, ONG, 8.4" LCD unit)	A02B-0323-C120#T	04	
Small MDI unit (for machining center system, ONG, 8.4" LCD unit)	A02B-0323-C120#M	08	
Standard MDI unit (for lathe system, ONG, 8.4" display unit)	A02B-0323-C121#T	40	
Standard MDI unit (for machining center system, ONG, 8.4" LCD unit)	A02B-0323-C121#M	02	
Standard MDI unit (for lathe system, ONG, horizontal type)	A02B-0323-C125#T	40	
Standard MDI unit (for machining center system, ONG, Horizontal type)	A02B-0323-C125#M	02	
Standard MDI unit (lathe system, ONG, Vertical type)	A02B-0323-C126#T	40	
Standard MDI unit (machining center system, ONG, vertical type)	A02B-0323-C126#M	02	
Standard MDI unit (QWERTY)	A02B-0323-C128	20	
Standard MDI unit (QWERTY TYPE B)	A02B-0323-C129	21	

## B.6 OTHER UNITS

Item	Specification	Remark
I/O module for connector panel (basic module)	A03B-0824-C001	DI/DO : 24/16
I/O module for connector panel (extension module A)	A03B-0824-C002	DI/DO : 24/16 With manual pulse generator interface
I/O module for connector panel (extension module B)	A03B-0824-C003	DI/DO : 24/16 Without manual pulse generator interface
I/O module for connector panel (extension module C)	A03B-0824-C004	DO : 16 2A output module
I/O module for connector panel (extension module D)	A03B-0824-C005	Analog input module
Flat cable between modules for I/O module for connector panel	A03B-0815-K100	Cable length: 20mm Applicable to an inter-module distance of 32 mm
I/O module for operator's panel	A03B-0824-K200	
I/O module for operator's panel (with MPG interface)	A03B-0824-K202	DI/DO : 48/32 With manual pulse generator interface
I/O module for power magnetics cabinet (without MPG interface)	A03B-0824-K203	DI/DO : 48/32 Without manual pulse generator interface
I/O module type-2 for connector panel (basic module B1)	A03B-0824-C040	DI/DO : 48/32 With manual pulse generator interface
I/O module type-2 for connector panel (basic module B2)	A03B-0824-C041	DI/DO : 48/32 Without manual pulse generator interface
I/O module type-2 for connector panel (extension module E1)	A03B-0824-C042	DI/DO : 48/32
Flat cable between modules for I/O module type-2 for connector panel	A03B-0815-K102	Cable length: 35mm Inter-module distance: 5mm

Item	Specification	Remark
Terminal type I/O module Basic module	A03B-0823-C011	DI/DO : 24/16
Terminal type I/O module Extension module A	A03B-0823-C012	DI/DO : 24/16 With manual pulse generator interface
Terminal type I/O module Extension module B	A03B-0823-C013	DI/DO : 24/16 Without manual pulse generator interface
Terminal type I/O module Extension module C	A03B-0823-C014	DO : 16 2A output module
Terminal type I/O module Extension module D	A03B-0823-C015	Analog input module
Terminal type I/O module Extension module E	A03B-0823-C016	Analog output module
Spare terminals set (for basic and extension module A/B)	A03B-0823-K020	Terminal block for cable side (With one piece of each of T1 to T4 included)
Spare terminals set (for extension module C)	A03B-0823-K011	Terminal block for cable side for extension module C (With one piece of each of T1 and T2 included)
Spare terminals set (for extension module D)	A03B-0823-K012	Terminal block for cable side for extension module D (With one piece of each of T1 and T2 included)
Spare terminals set (for extension module E)	A03B-0823-K013	Terminal block for cable side for extension module E (With one piece of each of T1 and T2 included)
Flat cable A between modules for terminal type I/O module	A03B-0823-K100	Cable length: 100mm, 52 pins Used to connect an extension module
I/O Link connection unit	A02B-0333-C250	
Machine operator's panel: Main panel	A02B-0323-C231	
Machine operator's panel: Sub panel A	A02B-0236-C232	
Machine operator's panel: Sub panel D	A02B-0236-C244	
FANUC I/O Link-AS-i converter (for AS-i Ver.2.0)	A03B-0817-C001	
FANUC I/O Link-AS-i converter (for AS-i Ver.2.1)	A03B-0817-C002	
I/O Link signal divider (2ch)	A20B-1007-0680	
I/O Link signal divider (3ch)	A20B-1008-0360	
Separate detector interface unit (basic 4 axes)	A02B-0323-C205	
Separate detector interface unit (additional 4 axes)	A02B-0323-C204	
Analog input separate detector interface unit (basic 4 axes)	A06B-6061-C202	
Optical I/O Link adapter	A13B-0154-B001	
Optical I/O Link adapter (high-speed type)	A13B-0154-B004	
Optical junction adapter for I/O Link	A63L-0020-0002	
Low-loss optical junction adapter	A63L-0020-0004	
Battery case installed outside for control (for LCD-mounted type control unit)	A02B-0236-C282	
Cable for battery case installed outside for control (for LCD-mounted type control unit)	A02B-0323-K103	
Battery case installed outside for control (for stand-alone type control unit)	A02B-0236-C281	With cable for battery
Compact flash card (128MB)	A02B-0281-K601	For data backup For Date Server
Compact flash card (256MB)	A02B-0213-K211	For data backup For Date Server

B. LISTS OF UNITS, PRINTED CIRCUIT  
BOARDS, AND CONSUMABLES

APPENDIX

B-64485EN/01

Item	Specification	Remark
Compact flash card (1GB)	A02B-0213-K212	For data backup For Date Server
Compact flash card (2GB)	A02B-0213-K213	For data backup For Date Server
Compact flash card (4GB)	A02B-0213-K214	For Date Server
Compact flash card adapter A	A02B-0303-K150	
Compact flash card adapter B	A02B-0236-K150	Adapter which converts the compact flash card to the ATA card.
PC-side HSSB interface board (2CH.) Compatible with the PCI bus	A20B-8101-0162	
PC-side HSSB interface board (1CH.) Compatible with the PCI bus	A20B-8101-0163	

## B.7 Consumables

Item		Specification	Remark	
Fuse	LCD-mounted type	For control unit (8.4" LCD unit)	A02B-0236-K100	
		For control unit (10.4" LCD unit A)		
		For control unit (10.4" LCD unit B)	A02B-0236-K101	
		For control unit (15" LCD unit)		
		For control unit (personal computer function with Windows® CE)		
	Stand-alone type	For control unit	A02B-0265-K100	
		For display unit (10.4" LCD unit A)	A02B-0303-K101	
		For display unit (10.4" LCD unit B)	A02B-0236-K100	
		For display unit (15" LCD unit)		
		For display unit (personal computer function with Windows® CE)		
	Others	For operator's panel I/O module	A03B-0815-K001	
		For standard machine operator's panel		
For connector panel I/O module		A03B-0815-K002		
For operator's panel connection unit		A02B-0163-K111		
For I/O Link-AS-i		A03B-0815-K001		
	For terminal type I/O module	A03B-0823-K001		
Fan motor	LCD-mounted type	For basic unit (no slot)	A02B-0323-K120	40 mm square, 2 units
		For basic unit (1 slot)	A02B-0323-K124	40 mm square, 1 unit 60 mm square, 1 unit (for 1 slot)
		For basic unit (2 slots)	A02B-0323-K125	40 mm square, 1 unit 60 mm square, 1 unit (for 2 slots)
	Stand-alone type	For basic unit (2 slots)	A02B-0303-K120	
		For basic unit (4 slots)	A02B-0303-K122	
		For display unit (personal computer function with Windows® CE)	A02B-0323-K120	
		For PANEL <i>i</i> (40-mm square)	A08B-0084-K100	
		For PANEL <i>i</i> (60-mm square)	A08B-0084-K101	
		For PANEL <i>i</i> (for HDD unit)	A08B-0084-K102	



Item		Specification	Remark
Screw caps	With 100 pieces included	A02B-0319-K190	
	With 5 pieces included	A02B-0319-K191	
Battery	For LCD-mounted type control unit memory backup	A02B-0323-K102	
	For stand-alone type control unit memory backup	A02B-0200-K102	
	For PANEL <i>i</i>		
	For separate absolute Pulsecoder	A06B-6050-K061	
Packing	For 8.4" LCD unit, For standard MDI unit (ONG, 8.4" LCD unit)	A02B-0323-K302	
	For 10.4" LCD unit, For standard MDI unit (ONG, vertical type)	A02B-0323-K301	
	For 12.1" LCD unit	A02B-0323-K300	
	For 15" LCD unit	A02B-0323-K304	
	For display unit for automotive manufacture	A02B-0323-K306	
	For standard MDI unit (ONG, horizontal type)	A02B-0323-K310	
	For small MDI unit (ONG, 8.4" LCD unit)	A02B-0323-K313	
	For standard MDI unit (QWERTY)	A02B-0323-K314	
	For standard MDI unit (QWERTY type B)	A02B-0323-K315	
	For main panel for machine operator's panel	A02B-0323-K320	
	Protection cover	For 8.4" LCD unit	A02B-0323-K112
For 10.4" LCD unit		A02B-0323-K113	
For 12.1" LCD unit		A02B-0323-K114	
For 15" LCD unit		A02B-0323-K115	
Protection sheet for touch panel	For 10.4" LCD unit	A02B-0236-K110	
	For 12.1" LCD unit	A02B-0236-K118	
	For display unit for automotive manufacture	A08B-0082-K020	
	For 15" LCD unit		
Pen for the touch panel		A02B-0236-K111	

# C BOOT SYSTEM

Appendix C, "BOOT SYSTEM", consists of the following sections:

C.1 OVERVIEW .....	744
C.2 SCREEN CONFIGURATION AND OPERATING PROCEDURE .....	747
C.3 ERROR MESSAGES AND REQUIRED ACTIONS .....	759

## C.1 OVERVIEW

The boot system load the CNC system software (Flash ROM → DRAM), then starts it so that software can be executed.

The boot system provides the following maintenance functions for the CNC:

- (1) Registering a file in Flash ROM  
A file is read from the FAT16-formatted memory card and written to the flash memory.  
(A FAT32-formatted memory card cannot be recognized.)
- (2) Checking a file (series and edition) in Flash ROM
- (3) Checking a file (series and edition) in Memory card
- (4) Deleting a file from Flash ROM
- (5) Deleting a file from Memory card
- (6) Saving a file in Flash ROM to a Memory card
- (7) Batch saving and restoration of files of parameters and programs backed up by battery (SRAM area), to and from a Memory card
- (8) Formatting of a Memory card

This manual describes the activation of the boot system, as well as the screen displays and operation for the functions listed above.

### CAUTION

- 1 This control unit supports the use of a Memory card as an input/output device.  
The Flash ATA card is available:  
See the order list for details of the supported Memory card types.
- 2 On a Memory card, only those files that are in the root directory can be accessed for display, reading, and writing. Those in subdirectories cannot be used.
- 3 The time required to read or write each data item varies depending on the Memory card type, the status of use, and other factors.
- 4 No normal operation can be guaranteed for any memory cards other than those purchased from FANUC.
- 5 When formatting a flash ATA card, use the quick formatting method, which clears the file allocation table and the directory information on the root directory. An unformatted flash ATA card needs to be formatted in FAT16 with a PC or the like. (A FAT32-formatted ATA card cannot be recognized.)

## C.1.1 Displaying the Power ON Sequence

(1)	RAM TEST :END	
(2)	ROM TEST :END [60W1A]	
(3)	DRAM ID :xxxxxxxx	
(4)	SRAM ID :xxxxxxxx	
(5)	FROM ID :xxxxxxxx	
(7)	*** MESSAGE *** LOADING CNC DATA-1        xxxxxxxx/xxxxxxx END	
(2)	RAM TEST :END ROM TEST :ERROR	Processing is stopped in the event of an error
(6)	*** MESSAGE *** ROM PARITY ERROR:NC BASIC. HIT SELECT.  [SELECT] [ YES ] [ NO ] [ UP ] [ DOWN ]	SELECT key → SYSTEM MONITOR

Fig. C.1 (a)

### Details of display items

- (1) WORK RAM test results are displayed. In the event of an error, however, the sequence is not displayable, and LED indication is conducted without error display.
- (2) BOOT ROM parity test results are displayed. During normal operation, the series and edition are displayed. In the event of an error, processing is stopped.
- (3) The ID of the DRAM MODULE installed in the CNC is displayed.
- (4) The ID of the SRAM MODULE installed in the CNC is displayed.
- (5) The ID of the FROM MODULE installed in the CNC is displayed.
- (6) The CNC BASIC software in flash memory is checked for validity and, in the event of an error, an error is displayed. In the event of an error, clicking the [SELECT] soft key allows you to select the SYSTEM MONITOR screen.
- (7) This message indicates that the CNC BASIC software is being transferred to flash memory to DRAM.

## C.1.2 Starting the Boot System

In ordinary system activation, the boot system automatically transfers files from Flash ROM to DRAM in the background.

The user is not aware of this operation. However, the boot system must be operated manually, from menu screen, when maintenance is to be carried out or when the Flash ROM does not contain a required file.

- (1) In system maintenance, for example, to replace a file in ROM Operation : Turn the power on by simultaneously pressing the two soft keys at the right end. If no soft keys are provided as with a touch panel, use MDI numeric keys 6 and 7.

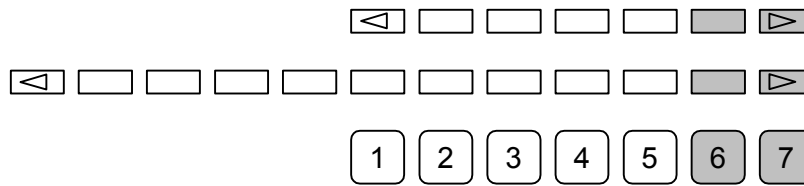

Fig. C.1 (b)

After an FROM ID and other items are displayed on the CNC screen, releasing the key brings you to the SYSTEM MONITOR screen.

- (2) When the flash memory does not contain a file required to start the CNC  
Immediately after the CNC is turned on, the boot system starts transferring files from Flash ROM to DRAM. If, for some reason, a file required to start the CNC (NC BASIC) is not in Flash ROM or has been destroyed, the boot system is automatically started.

### C.1.3 System Files and User Files

The boot system organizes files in Flash ROM into two main groups : system files and user files. These two file types have the following characteristics :

#### System files

CNC and servo control software provided by FANUC

#### User files

PMC sequence program (ladder), P-CODE macro program, and other user-created files

#### Naming convention for user files

Each of the files in flash ROM has a specific name based on its type. These file names are used by the following items described later.

- SYSTEM DATA CHECK
- SYSTEM DATA DELETE
- SYSTEM DATA SAVE

The correspondence between the file names and their types is shown below.

Table C.1 (a)

File name	Type
PMC□	Ladder
PMCS	Ladder (for dual check safety)
M□PMCMMSG	PMC message multi-language data
CEX □.□M	C Language Executor user application
CEX□○○○○	C Language Executor user data
PD□□ □□□	Macro executor user application

□: One numeric

○: One alphanumeric

## C.2 SCREEN CONFIGURATION AND OPERATING PROCEDURE

When the boot system is first started, the MAIN MENU screen is displayed. This screen is described below :

### MAIN MENU screen

<p>(1) SYSTEM MONITOR MAIN MENU 60W1 - 01</p> <p>(2) 1.END</p> <p>(3) 2.USER DATA LOADING</p> <p>(4) 3.SYSTEM DATA LOADING</p> <p>(5) 4.SYSTEM DATA CHECK</p> <p>(6) 5.SYSTEM DATA DELETE</p> <p>(7) 6.SYSTEM DATA SAVE</p> <p>(8) 7.SRAM DATA BACKUP</p> <p>(9) 8.MEMORY CARD FORMAT</p> <p>*** MESSAGE ***</p> <p>(10) SELECT MENU AND HIT SELECT KEY.</p> <p>[SELECT][ YES ][ NO ][ UP ][ DOWN ]</p>	<p>(1) Screen title. The series and edition of the BOOT SYSTEM are displayed at the right end.</p> <p>(2) Function for terminating the boot system and starting the CNC.</p> <p>(3) Function for writing data to Flash ROM.</p> <p>(4) Function for writing data to Flash ROM.</p> <p>(5) Function for checking the edition of a file in ROM.</p> <p>(6) Function for deleting a file from Flash ROM or Memory card.</p> <p>(7) Function for making a backup copy of the data stored on the Memory card.</p> <p>(8) Function for backing up and restoring the SRAM area</p> <p>(9) Function for formatting a Memory card.</p> <p>(10) Simple operating instructions and error messages are displayed.</p>
---	---

Fig. C.2 (a)

### Operating procedure

Press the [UP] or [DOWN] soft key to select the desired function. After positioning the cursor to the desired function, press the [SELECT] soft key. Before executing a function, for a confirmation, it maybe need to press the [YES] or [NO] soft key.

### Basic operation

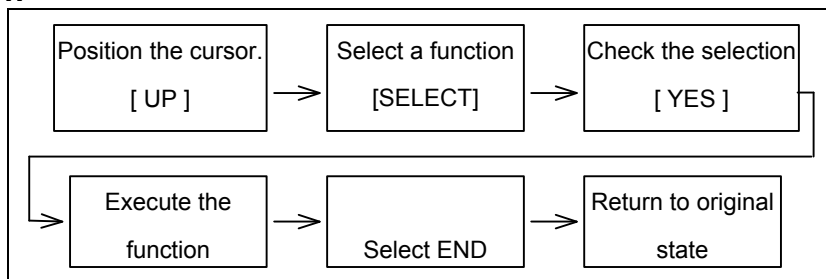

Fig. C.2 (b)

## C.2.1 USER DATA LOADING/SYSTEM DATA LOADING Screen

### Description

This screen is used to read a system or user file from a Memory card into Flash ROM.

The USER DATA LOADING screen is used to load ROM data from a Memory card to flash memory.

The SYSTEM DATA LOADING screen is used to check the contents of the ROM card installed in a Memory card and then load ROM data from the Memory card to flash memory.

### Screen configuration

<p>(1) SYSTEM DATA LOADING  (2) MEMORY CARD DIRECTORY (FREE[KB]: 5123)  (3) 1 G001A_B1.MEM 1048704 2003-01-01 12:00  2 G001A_B2.MEM 1048704 2003-01-01 12:00  (4) 3 END    *** MESSAGE ***  (5) SELECT MENU AND HIT SELECT KEY.    [SELECT] [ YES ] [ NO ] [ UP ] [ DOWN ]</p>	<p>(1) Screen title.  (2) The size of the free space of the Memory card is displayed.  (3) A list of files in the Memory card is displayed.  (4) Returning to the MAIN MENU.  (5) Message</p>
--	---

Fig. C.2 (c)

### Operating procedure

(1) Position the cursor to the file to be read from the Memory card and written to Flash ROM. Then, press the [SELECT] soft key.

- A single page can list up to ten file names.
- If the Memory card contains ten or more files, the remaining files are displayed on another page.

To display the next page, press the  soft key.

To display the previous page, press the  soft key. The END option is displayed on the last page.

(2) When you select a file from the USER DATA LOADING screen, you are prompted for confirmation.

```

SYSTEM DATA LOADING
MEMORY CARD DIRECTORY (FREE[KB]: 5123)
 1 G001A_B1.MEM 1048704 2003-01-01 12:00
 2 G001A_B2.MEM 1048704 2003-01-01 12:00
 3 END

*** MESSAGE ***
LOADING OK ? HIT YES OR NO.

[SELECT] [ YES ] [ NO ] [ UP ] [ DOWN ]

```

Fig. C.2 (d)

- (3) When you select a file from the SYSTEM DATA LOADING screen, a ROM data confirmation screen is displayed for confirmation.

```

SYSTEM DATA CHECK & DATA LOADING
G001A_B1.MEM
 1 G001 001A
 2 G001 021A
 3 G001 041A
 4 G001 061A
 5 G001 081A
 6 G001 0A1A
 7 G001 0C1A
 8 G001 0E1A

*** MESSAGE ***
LOADING OK ? HIT YES OR NO.

[SELECT] [ YES ] [ NO ] [ UP ] [ DOWN ]

```

**Fig. C.2 (e)**

- (4) To start loading, press the [YES] soft key. To cancel, press the [NO] key.

```

*** MESSAGE ***
LOADING FROM MEMORY CARD xxxxxx/xxxxxx

[SELECT] [ YES ] [ NO ] [ UP ] [ DOWN ]

```

**Fig. C.2 (f)**

- (5) When loading terminates normally, the system displays the following message. Press the [SELECT] soft key. If an error occurs, see C.3

```

*** MESSAGE ***
LOADING COMPLETE.
HIT SELECT KEY.
[SELECT] [ YES ] [ NO ] [ UP ] [ DOWN ]

```

**Fig. C.2 (g)**

#### **NOTE**

The CNC option parameters corresponding to the “FANUC Remote Option System” are held in an option information file (named “OPRM INF”) in FROM. Rewriting this file amounts to re-setting option parameters and therefore requires authenticating them by FANUC. Please ask FANUC to authenticate the option parameters.

## C.2.2 SYSTEM DATA CHECK Screen

### Description

This screen is used to list files in Flash ROM or Memory card, together with the corresponding numbers of management units in each file and the series and edition of the software.

### Screen configuration

(1)	SYSTEM DATA CHECK	(1) Screen title.
(2)	1.FROM SYSTEM	(2) Select the FROM SYSTEM screen.
(3)	2.MEMORY CARD SYSTEM	(3) Select the MEMORY CARD SYSTEM screen.
(4)	3.END	(4) Returning to the MAIN MENU.
(5)	*** MESSAGE *** SELECT MENU AND HIT SELECT KEY.  [SELECT][ YES ][ NO ][ UP ][ DOWN ]	(5) Message

Fig. C.2 (h)

### Screen configuration (FROM SYSTEM screen)

(1)	SYSTEM DATA CHECK	(1) Screen title.
(2)	FROM DIRECTORY	(2) Names of files in Flash ROM The number of management units constituting each file appears in parentheses to the right of the filename.
(3)	1 NC BAS-1(0008) 2 NC BAS-2(0008) 3 NC BAS-3(0008) 4 NC BAS-4(0008) 5 DGDOSRVO(0003) 6 PS0B (0006) 7 END	(3) Returning to the MAIN MENU.
(4)	*** MESSAGE *** SELECT FILE AND HIT SELECT KEY.  [SELECT][ YES ][ NO ][ UP ][ DOWN ]	(4) Message

Fig. C.2 (i)



### Screen configuration (MEMORY CARD SYSTEM screen)

(1)	SYSTEM DATA CHECK	(1) Screen title.
(2)	MEMORY CARD DIRECTORY (FREE [KB]: 5123)	(2) The size of the free space of the Memory card is displayed.
(3)	1 G001A_B1.MEM 1048704 2003-01-01 12:00	(3) A list of files in the Memory card is displayed.
(4)	2 G001A_B2.MEM 1048704 2003-01-01 12:00 3 END	(4) Returning to the MAIN MENU.
(5)	*** MESSAGE *** SELECT FILE AND HIT SELECT KEY.  [SELECT] [ YES ] [ NO ] [ UP ] [ DOWN ]	(5) Message

Fig. C.2 (j)

### Operating procedure

- (1) Select either the FROM SYSTEM or MEMORY CARD SYSTEM screen.
- (2) Select the file that you want to confirm (for example, "NC BAS-1 (0008)").
- (3) For the selected file, the management unit numbers are listed, together with the series and editions of the management units. After checking the listed data, select the [SELECT] soft key to return to the file selection screen.

(1)	SYSTEM DATA CHECK	(1) Screen title.
(2)	NC BAS-1 (0008) 1 G001 001A 0000 2 G001 021A 0001 3 G001 041A 0002 4 G001 061A 0003 5 G001 081A 0004 6 G001 0A1A 0005 7 G001 0C1A 0006 8 G001 0E1A 0007  *** MESSAGE ***  HIT SELECT KEY. [SELECT] [ YES ] [ NO ] [ UP ] [ DOWN ]	(2) The following items are displayed for each management unit: - Series - ROM number and edition - Internal management-unit number If a check result cannot be displayed, a "@" is displayed.

Fig. C.2 (k)

### Others (Parity information for the system file and user file)

The NC BAS-1, DGD0SRVO, and other system files in Flash ROM contain parity information in each management unit. If the file name field or parity field on the check screen contains a non-ASC II character or an "@", the Flash ROM may have been destroyed or a damaged file may have been read. Re-read the data from the Memory card.

The PMC1, and other user files do not contain parity information in each management unit. A non-ASCII character or an "@" may appear in the series/edition information. In this case, it does not indicate that the file has been damaged.

## C.2.3 SYSTEM DATA DELETE Screen

### Description

This screen is used to delete a user file from Flash ROM or Memory card.

### Screen configuration

<p>(1) SYSTEM DATA DELETE</p> <p>(2) 1.FROM SYSTEM</p> <p>(3) 2.MEMORY CARD SYSTEM</p> <p>(4) 3.END</p> <p>*** MESSAGE ***</p> <p>(5) SELECT MENU AND HIT SELECT KEY.</p> <p>[SELECT] [ YES ] [ NO ] [ UP ] [ DOWN ]</p>	<p>(1) Screen title.</p> <p>(2) Select the FROM SYSTEM screen.</p> <p>(3) Select the MEMORY CARD SYSTEM screen.</p> <p>(4) Returning to the MAIN MENU.</p> <p>(5) Message</p>
--	---

Fig. C.2 (l)

### Screen configuration (FROM SYSTEM screen)

<p>(1) SYSTEM DATA DELETE</p> <p>FROM DIRECTORY</p> <p>(2) 1 NC BAS-1(0008)</p> <p>2 NC BAS-2(0008)</p> <p>3 NC BAS-3(0008)</p> <p>4 NC BAS-4(0008)</p> <p>5 DGD0SRVO(0003)</p> <p>6 PS0B (0006)</p> <p>7 PMC1 (0001)</p> <p>(3) 8 END</p> <p>*** MESSAGE ***</p> <p>(4) SELECT FILE AND HIT SELECT KEY.</p> <p>[SELECT] [ YES ] [ NO ] [ UP ] [ DOWN ]</p>	<p>(1) Screen title.</p> <p>(2) Names of files in Flash ROM The number of management units constituting each file appears in parentheses to the right of the filename.</p> <p>(3) Returning to the MAIN MENU.</p> <p>(4) Message</p>
---	--

Fig. C.2 (m)

### Screen configuration (MEMORY CARD SYSTEM screen)

<p>(1) SYSTEM DATA DELETE</p> <p>(2) MEMORY CARD DIRECTORY (FREE [KB]: 5123)</p> <p>(3) 1 G001A_B1.MEM 1048704 2003-01-01 12:00</p> <p>2 G001A_B2.MEM 1048704 2003-01-01 12:00</p> <p>(4) 3 END</p> <p>*** MESSAGE ***</p> <p>(5) SELECT FILE AND HIT SELECT KEY.</p> <p>[SELECT] [ YES ] [ NO ] [ UP ] [ DOWN ]</p>	<p>(1) Screen title.</p> <p>(2) The size of the free space of the Memory card is displayed.</p> <p>(3) A list of files in the Memory card is displayed.</p> <p>(4) Returning to the MAIN MENU.</p> <p>(5) Message</p>
--	---

Fig. C.2 (n)

### Operating procedure

- (1) Select either the FROM SYSTEM or MEMORY CARD SYSTEM screen.
- (2) Select the file you want to delete.
- (3) The following message is displayed for confirmation.

```
*** MESSAGE ***
DELETE OK ? HIT YES OR NO.

[SELECT] [ YES ] [ NO ] [ UP ] [ DOWN ]
```

**Fig. C.2 (o)**

- (4) To start deleting, press the [YES] soft key. To cancel, press the [NO] key.

```
*** MESSAGE ***
EXECUTING
ADDRESS xxxx:
[SELECT] [ YES ] [ NO ] [ UP ] [ DOWN ]
```

**Fig. C.2 (p)**

- (5) When deleting terminates normally, the system displays the following message. Press the [SELECT] soft key. If an error occurs, see C.3

```
*** MESSAGE ***
DELETE COMPLETE. HIT SELECT KEY.

[SELECT] [ YES ] [ NO ] [ UP ] [ DOWN ]
```

**Fig. C.2 (q)**

### Others (System files and user files on SYSTEM DATA DELETE screen)

The system files are protected from accidental deletion. User files, however, are not protected. Protected system files can be overwritten from the USER DATA LOADING / SYSTEM DATA LOADING screen.

## C.2.4 SYSTEM DATA SAVE Screen

### Description

This screen is used to write a user file in Flash ROM to a Memory card. Only user files can be saved from Flash ROM to a Memory card. System files cannot be saved.

### Screen configuration

<p>(1) SYSTEM DATA SAVE FROM DIRECTORY</p> <p>(2) 1 NC BAS-1(0008) 2 NC BAS-2(0008) 3 NC BAS-3(0008) 4 NC BAS-4(0008) 5 DGD0SRVO(0003) 6 PS0B (0006) 7 PMC1 (0001) 8 END</p> <p>(3) *** MESSAGE ***</p> <p>(4) SELECT FILE AND HIT SELECT KEY.  [SELECT] [ YES ] [ NO ] [ UP ] [ DOWN ]</p>	<p>(1) Screen title.</p> <p>(2) Names of files in Flash ROM The number of management units constituting each file appears in parentheses to the right of the filename.</p> <p>(3) Returning to the MAIN MENU.</p> <p>(4) Message</p>
---	--

Fig. C.2 (r)

### Operating procedure

- (1) Select the file you want to save.
- (2) The system displays the following confirmation message :

```
*** MESSAGE ***
SYSTEM DATA SAVE OK ? HIT YES OR NO.

[SELECT] [ YES ] [ NO ] [ UP ] [ DOWN ]
```

Fig. C.2 (s)

- (3) To start saving, press the [YES] key. To cancel, press [NO].

```
*** MESSAGE ***
STORE TO MEMORY CARD

[SELECT] [ YES ] [ NO ] [ UP ] [ DOWN ]
```

Fig. C.2 (t)

- (4) When saving terminates normally, the system displays the following message. Press the [SELECT] key. The names of files written to the Memory card are listed. Check the file names by, for example, making a note of the list.

```
*** MESSAGE ***
FILE SAVE COMPLETE. HIT SELECT KEY.
SAVE FILE NAME : PMC1.000
[SELECT] [ YES ] [ NO ] [ UP ] [ DOWN ]
```

Fig. C.2 (u)

**Saving ATA PROG**

A file whose file name is ATA PROG contains an NC program. Even if you want to save this file, if the boot software is of the 60W1/07 edition or later, you cannot save it on this SYSTEM DATA SAVE screen, because it is saved together with SRAM data on the SRAM DATA UTILITY screen.

**Others (System files and user files on SYSTEM DATA SAVE screen)**

The SYSTEM DATA SAVE function provides a safeguard against free copying of the system files.

User files, however, are not protected.

Files saved from Flash ROM to a Memory card have the following names :

**Table C.2 (b)**

Header ID in Flash ROM		File name in Memory card
PMC1	→	PMC1.xxx
PD010.5M	→	PD0105M.xxx
PD011.0M	→	PD0110M.xxx

"xxx" is replaced by one of 32 numbers "000", "001", ..., and "031".

For example, if you attempt to save the file "PMC1 " from Flash ROM to a Memory card, it will be saved with a name of "PMC1.000" if no file with a name of "PMC1.000" is found on the Memory card. If, however, that file is saved to a Memory card that already contains a file named PMC1.000, the saved file is named PMC1.001. As files are added, the extension is incremented up to a maximum of PMC1.031. Any no-longer used numbers in the sequence of the extension numbers are used in as sending order. If two or more files having identical names but different extension numbers are normally saved to the Memory card, check the file names displayed subsequently.

**C.2.5 SRAM DATA UTILITY Screen**

**Description**

This screen is used to collectively save and restore parameters, programs, and other data, retained after the CNC power in SRAM is turned off, to and from a Memory card.

**Screen configuration**

<p>(1) SRAM DATA UTILITY</p> <p>(2) 1.SRAM BACKUP ( CNC -&gt; MEMORY CARD ) 2.RESTORE SRAM ( MEMORY CARD -&gt; CNC )</p> <p>(3) 3.END</p> <p>(4) SRAM + ATA PROG FILE : (4MB)</p> <p>(5) SRAM_BAK.001</p> <p>*** MESSAGE *** SET MEMORY CARD NO.001 ARE YOU SURE ? HIT YES OR NO. [SELECT][ YES ][ NO ][ UP ][ DOWN ]</p>	<p>(1) Screen title.</p> <p>(2) Menu</p> <p>(3) Returning to the MAIN MENU.</p> <p>(4) The SRAM file size is displayed. (Displayed after a processing option is selected.)</p> <p>(5) The name of the file currently being saved or loaded is displayed. (Displayed after a processing option is selected.)</p>
---	---

**Fig. C.2 (v)**

**Operating procedure (Backing up data)**

(1) Select "1.SRAM BACKUP" The following confirmation message is displayed. To start backup, press the [YES] soft key.

- (2) If the data cannot be saved entirely onto a single Memory card, a message such as that shown below is displayed. With the power still on, insert the second Memory card and press the [YES] key. Press the [NO] key to cancel saving.

```
*** MESSAGE ***
SET MEMORY CARD NO.002
ARE YOU SURE ? HIT YES OR NO.
[SELECT] [ YES ] [ NO ] [ UP ] [ DOWN ]
```

**Fig. C.2 (w)**

- (3) In this way, you can divide SRAM data onto a maximum of 999 Memory card for backup.
- (4) Upon the termination of backup, the system displays the following message. Press the [SELECT] soft key.

```
*** MESSAGE ***
SRAM BACKUP COMPLETE. HIT SELECT KEY.

[SELECT] [ YES ] [ NO ] [ UP ] [ DOWN ]
```

**Fig. C.2 (x)**

### Operating procedure (Restoring the data)

- (1) Select "2.RESTORE SRAM" The following confirmation message is displayed. To start restoration, press the [YES] soft key.
- (2) A message such as that shown below is displayed. Insert the first Memory card containing SRAMBACK.001 and press the [YES] key. Press the [NO] key to cancel restoration.

```
*** MESSAGE ***
SET MEMORY CARD INCLUDING SRAMBAK.001
ARE YOU SURE ? HIT YES OR NO.
[SELECT] [ YES ] [ NO ] [ UP ] [ DOWN ]
```

**Fig. C.2 (y)**

- (3) If another Memory card is required, a message such as that shown below is displayed. With the power still on, insert the second Memory card and press the [YES] key. Press the [NO] key to cancel restoration.

```
*** MESSAGE ***
SET MEMORY CARD INCLUDING SRAMBAK.002
ARE YOU SURE ? HIT YES OR NO.
[SELECT] [ YES ] [ NO ] [ UP ] [ DOWN ]
```

**Fig. C.2 (z)**

- (4) Replace the second card with another, if required. Repeat this step until backing up all data.
- (5) Upon the termination of restoration, the system displays the following message. Press the [SELECT] soft key.

```
*** MESSAGE ***
SRAM RESTORE COMPLETE. HIT SELECT KEY.

[SELECT] [ YES ] [ NO ] [ UP ] [ DOWN ]
```

**Fig. C.2 (aa)**

### CAUTION

- 1 Backup files will be created with a file name of SRAM\_BAK.xxx, where xxx is replaced with a number between 001 and 999 sequentially.  
On the first Memory card, a backup file is created with a name of SRAM\_BAK.001. If all data is not contained on the single card, a backup file containing the excess data is created with a name of SRAM\_BAK.002 on the second Memory card.  
In this way, you can divide data onto a maximum of 999 Memory cards for saving.
- 2 Check that the Memory card used for backup does not contain a file with a name of SRAM\_BAK.xxx before performing a BACKUP operation. You can check a list of file names on a Memory card by using the SYSTEM DATA LOADING function.
- 3 The Memory card used for backup needs to be formatted in FAT16.
- 4 The contents and name of a file to be backed up vary depending on the version of the boot software used.
  - 60W1/06 and earlier versions
    - Contents of file : SRAM data
    - File name : SRAMBAK.xxx
  - 60W1/07 and later versions
    - Contents of file : SRAM data, NC programs (ATA PROG to be saved in flash ROM)
    - File name : SRAM\_BAK.xxx

It is also possible to restore data by using software of a version later than one used to back it up.

## C.2.6 MEMORY CARD FORMAT Screen

### Description

This function is used to format a Memory card. Memory cards must be formatted before they can be used for the first time or before they can be re-used after their data has been destroyed or lost because of, for example, battery failure.

### Operating procedure

- (1) From the SYSTEM MONITOR MAIN MENU screen, select "8.MEMORY CARD FORMAT."
- (2) The system displays the following confirmation message. Press the [YES] key.

```
*** MESSAGE ***
MEMORY CARD FORMAT OK ? HIT YES OR NO.

[SELECT] [ YES ] [ NO ] [ UP ] [ DOWN ]
```

Fig. C.2 (bb)

- (3) The system displays the following message asking whether to delete all data on the Memory card. To format the Memory card, press the [YES] key.

```
*** MESSAGE ***
MEMORY CARD FORMAT OK ? HIT YES OR NO.
ALL DATA IN THE MEMORY CARD IS LOST.
[SELECT] [ YES ] [ NO ] [ UP ] [ DOWN ]
```

Fig. C.2 (cc)

- (4) The system displays the following message during formatting :

```
*** MESSAGE ***
FORMATTING MEMORY CARD.

[SELECT][ YES  ][ NO  ][ UP  ][ DOWN ]
```

Fig. C.2 (dd)

- (5) When a card has been formatted normally, the system display the following message. Press the [SELECT] soft key.

```
*** MESSAGE ***
FORMAT COMPLETE. HIT SELECT KEY.

[SELECT][ YES  ][ NO  ][ UP  ][ DOWN ]
```

Fig. C.2 (ee)

## C.2.7 LOAD BASIC SYSTEM

### Description

The function is used to terminate the boot system and activate the CNC.

### Operating procedure

From the MAIN MENU screen, select "1. END." The system displays the "ARE YOU SURE? HIT YES OR NO" message. To terminate the boot system and activate the CNC, press the [YES] soft key. Press the [NO] soft key, and you will be brought back to the MAIN MENU.

```
*** MESSAGE ***

ARE YOU SURE ? HIT YES OR NO.

[SELECT][ YES  ][ NO  ][ UP  ][ DOWN ]
```

Fig. C.2 (ff)

## C.2.8 Cautions

### ⚠ CAUTION

Bear the following cautions in mind if using boot software of the 60W1/06 edition or later:

When restoring the following data in this system, be sure to restore a pair of SRAM data and ATA PROG data which were backed up at the same time. (ATA PROG data is in flash ROM.)

- Restoring SRAM data
- Restoring ATA PROG data

SRAM data and ATA PROG data are related to each other. Storing either data would impair data consistency. (This may result in events such as destruction of program files.)

If, for some reason, you need to restore either SRAM or ATA PROG data only, be sure to initialize program files (perform a clear operation) before restoration.



## C.3 ERROR MESSAGES AND REQUIRED ACTIONS

The following table lists and explains error messages in alphabetical order.

Table C.3 (a)

	Message	Description and required action
D	DEVICE ERROR (xxxx)	An attempt to write data to Flash ROM was unsuccessful. Turn the power off and back on again. If the second attempt also fails, the Flash ROM module may have been damaged or destroyed. It is necessary to replace the Flash ROM module.
F	FILE CLOSE ERROR. HIT SELECT KEY.	Access to a Memory card failed. The Memory card's battery may have gone dead, the Memory card may have been damaged electrically, or the Memory card may not be inserted in the slot securely.
	FILE DELETE ERROR. HIT SELECT KEY.	Access to a Memory card failed. The Memory card's battery may have gone dead, the Memory card may have been damaged electrically, or the Memory card may not be inserted in the slot securely.
	FILE OPEN ERROR. HIT SELECT KEY.	Access to a Memory card failed. The Memory card's battery may have gone dead, the Memory card may have been damaged electrically, or the Memory card may not be inserted in the slot securely.
	FILE READ ERROR. HIT SELECT KEY.	Access to a Memory card failed. The Memory card's battery may have gone dead, the Memory card may have been damaged electrically, or the Memory card may not be inserted in the slot securely.
	FILE SAVE ERROR. HIT SELECT KEY.	Access to a Memory card failed. The Memory card's battery may have gone dead, the Memory card may have been damaged electrically, or the Memory card may not be inserted in the slot securely.
	FLASH MEMORY NO SPACE. HIT SELECT KEY.	There is insufficient free Flash ROM module to store the selected file. Delete any unnecessary files from Flash ROM. Alternatively, it is necessary to replace the Flash ROM module with another with a larger size.
I	ILLEGAL FORMAT FILE. HIT SELECT KEY.	The selected file cannot be read into Flash ROM. The selected file or the header information for Flash ROM may have been damaged or destroyed.
	ILLEGAL SRAM MODULE. HIT SELECT KEY.	The SRAM module ID is illegal. Check the drawing No. of the SRAM module.
M	MAX EXTENSION OVER. HIT SELECT KEY.	The extension number added to a file name exceeds 031. Either replace the Memory card or delete any unnecessary backup files.
	MEMORY CARD BATTERY ALARM. HIT SELECT KEY.	The Memory card's battery is exhausted. Replace the battery.
	MEMORY CARD DISMOUNT ERROR. HIT SELECT KEY.	Access to a Memory card failed. The Memory card's battery may have gone dead, the Memory card may have been damaged electrically, or the Memory card may not be inserted in the slot securely.
	MEMORY CARD FORMAT ERROR	Access to a Memory card failed. The Memory card's battery may have gone dead, the Memory card may have been damaged electrically, or the Memory card may not be inserted in the slot securely.
	MEMORY CARD FULL. HIT SELECT KEY.	The Memory card is full. Delete any unnecessary files from the Memory card. Alternatively, replace the Memory card with another card having sufficient free space.

	Message	Description and required action
M	MEMORY CARD MOUNT ERROR. HIT SELECT KEY.	The Memory card could not be accessed. Check that the Memory card has been FAT-formatted.
	MEMORY CARD NOT EXIST. HIT SELECT KEY.	The Memory card is not inserted into its slot. Check that the Memory card is pushed fully home.
	MEMORY CARD PROTECTED. HIT SELECT KEY.	Although writing to the Memory card was selected, the write inhibit switch is set. Disable the write inhibit switch.
	MEMORY CARD RESET ERROR. HIT SELECT KEY.	Access to a Memory card failed. The Memory card's battery may have gone dead, the Memory card may have been damaged electrically, or the Memory card may not be inserted in the slot securely.
R	ROM PARITY ERROR:NC BASIC. HIT SELECT.	NC BASIC data is not correct. Use SYSTEM DATA CHECK to check that CNC system software is installed.
S	SRAM TEST ERROR (ECC)	An error was detected in the SRAM module. You can start up the system because data has been automatically restored. It is necessary to replace the SRAM module, however, just in case that the data may be disarranged in the future.

# D MEMORY CARD SLOT

Appendix D, "MEMORY CARD SLOT", consists of the following sections:

D.1 OVERVIEW .....	761
D.2 MEMORY CARD TYPES (FUNCTIONS).....	761
D.3 HARDWARE CONFIGURATION .....	763

## D.1 OVERVIEW

Whether a memory card slot is provided or not depends on the hardware configuration. See the Table D.1 (a):

Table D.1 (a)

Hardware configuration	Card slot on LCD unit	Card slot on control unit
Type 1	Provided	No card slot
Type 2	Provided	Provided (This slot, however, cannot be used.)
Type 3	Provided (when PANEL <i>i</i> is used) (See NOTE given below.)	Provided

(Supplementary)

- Types 1 to 3 indicate hardware configuration. See Section D.3.

### NOTE

When the hardware configuration is type 3, software write operation and other operations are implemented by Personal Computer functions.

## D.2 MEMORY CARD TYPES (FUNCTIONS)

### NOTE

No normal operation can be guaranteed for any memory cards other than those purchased from FANUC.

### Use of the compact flash card adapter in the card slot on the display unit side

When a compact flash card is inserted into a compact flash card adapter (A02B-0303-K150) (referred to below as the CF adapter) purchased from FANUC, and then the CF adapter is inserted into the card slot on the display unit side, the compact flash card lock function is available, the memory card interface cover can be closed with the CF adapter inserted.

#### 1. Insertion

- Set a compact flash card in the CF adapter (A02B-0303-K150).
- Check that lock lever A is lifted, then insert the CF adapter into the memory card interface.
- Lower lock lever A.
- Close the memory card interface cover.

### NOTE

- 1 For continuous operation with a CF adapter inserted, be sure to lower lock lever A and close the memory card interface cover.

**NOTE**

- 2 The lock function is enabled only when a CF adapter (A02B-0303-K150) is used.
- 3 Insert a CF adapter so that the plane bearing the label faces the screen.

## 2. Extraction

- Open the cover of the memory card interface.
- Push up lock lever A.
- Push eject button B once. The button protrudes.
- Push eject button B again. The CF adapter is ejected.
- Hold the CF adapter with fingers and pull it out.
- Close the memory card interface cover.

**NOTE**

When the lock lever is lowered (locked), the eject button cannot be pushed.

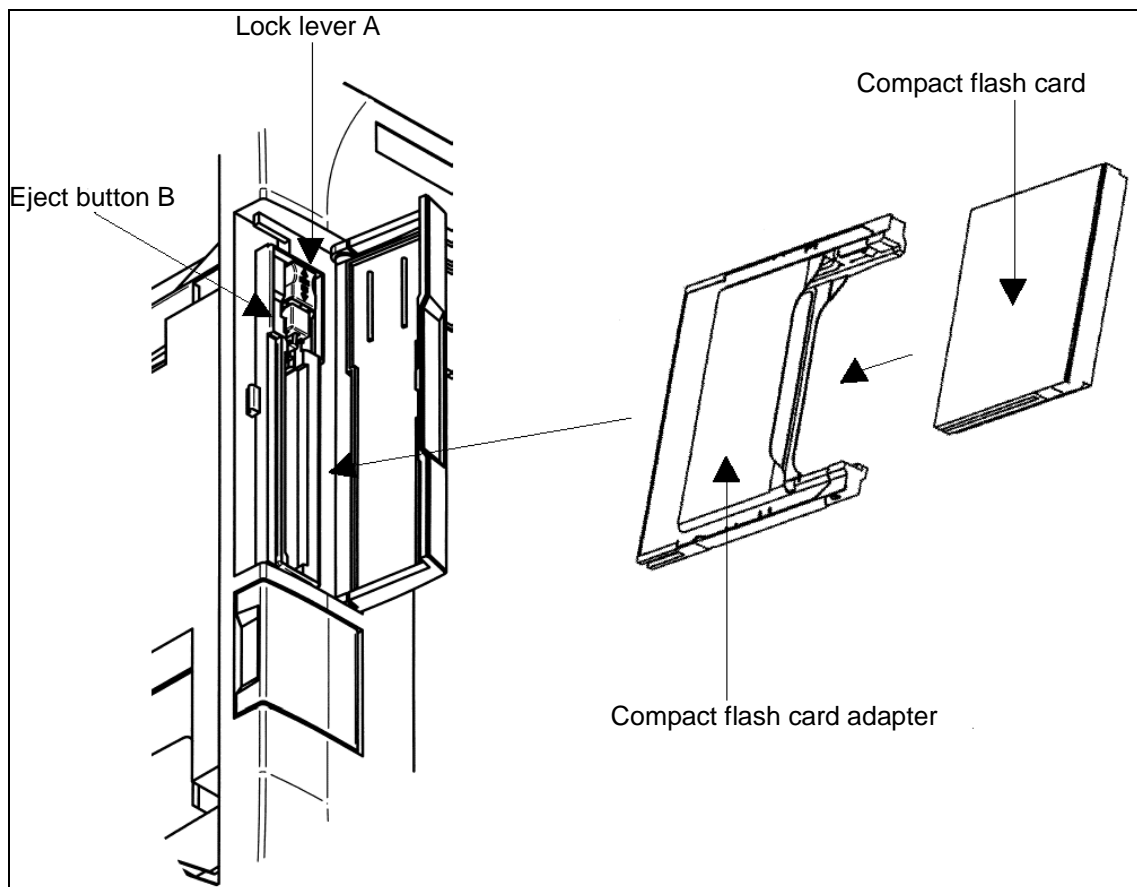

Fig. D.2 (a)

## D.3 HARDWARE CONFIGURATION

### Type 1

LCD-mounted type

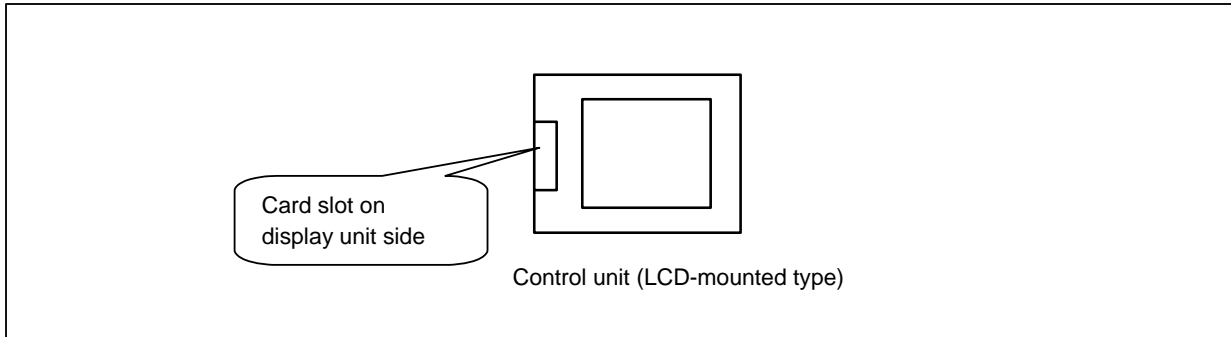

Fig. D.3 (a)

### Type 2

Stand-alone type (with an LCD unit)

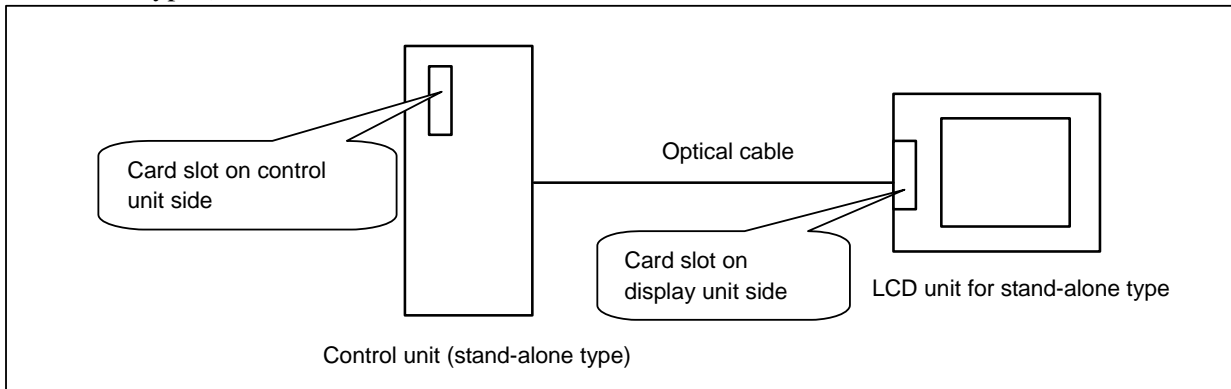

Fig. D.3 (b)

### Type 3

When the HSSB interface is used to connect the personal computer or PANEL *i*

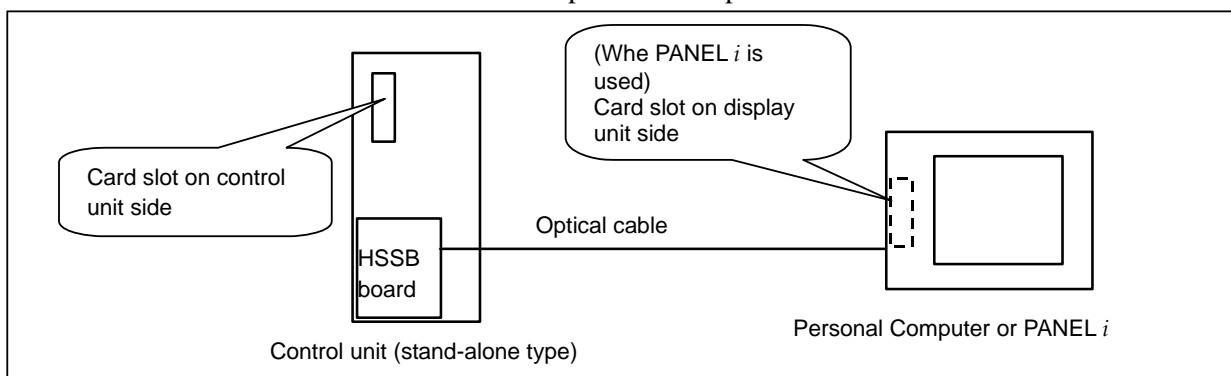

Fig. D.3 (c)

# E LED DISPLAY

Appendix E, "LED DISPLAY", consists of the following sections:

E.1 OVERVIEW .....764  
 E.2 7-SEGMENT LED INDICATIONS (TURNED ON).....764  
 E.3 7-SEGMENT LED INDICATIONS (BLINKING) .....766











## E.1 OVERVIEW

On the CNC, a 7-segment LED is installed.  
 The 7-segment LED indication changes according to the operating status of the CNC.  
 The 7-segment LED indications provided after the power is turned on until the CNC is ready for operation and when system errors occur are described below.

## E.2 7-SEGMENT LED INDICATIONS (TURNED ON)











Table E.2 (a) Meanings of LED Indications

LED Display	Meaning
	Power not turned on (power-off state)
	Initialization completed and ready for operation
	CPU started up (BOOT system)
	Initialization of G/A (BOOT system)
	Initialization of various functions
	Task initialization
	System configuration parameter check Additional board waiting 2
	Installation of various drivers All files cleared
	Title display System ROM test
	State where the CPU is not started after the power is turned on (BOOT system)
	BOOT system ended, NC system started (BOOT system)
	FROM initialization
	Loading of embedded software
	Loading of software for optional boards
	IPL monitoring in progress

LED Display	Meaning
	DRAM test error (BOOT system, NC system)
	BOOT system error (BOOT system)
	File cleared Optional board waiting 1
	Loading of basic system software (BOOT system)
	Fan motor check under way (BOOT system)
	Optional board waiting 3 Optional board waiting 4
	Final system operation check
	Fan motor faulty (BOOT system)
	Indicator initialization (BOOT system)
	FROM initialization (BOOT system) OPEN CNC BOOT (NCBOOT32) being executed
	BOOT monitoring in progress (BOOT system)

If processing stops during startup due to a CNC error, and the system alarm screen is not displayed, take corrective action referring to Table E.2 (b).

**Table E.2 (b) Faulty Regions and Check Items If Processing Stops during Startup**

LED display	Faulty region and check item
	The power supply (24V), backpanel (with power supply) (if the CNC is a LED-mounted type control unit), or power supply unit (if the CNC is a stand-alone type control unit) may be defective.
	Check that the HSSB cable is attached correctly (if the CNC is a stand-alone type control unit).
	The main board or the stand-alone type display may be faulty.
	Check the alarm LED "CCPUALM" (Note) on the main board. If "CCPUALM" is lit : The CPU card may be fault. If "CCPUALM" is not lit : The main board may be faulty.
	The main board may be faulty.
	The CPU card may be faulty.
	The FROM/SRAM module or the main board may be faulty.
	The main board or the stand-alone type display may be faulty.
	The CPU card may be faulty.
	The fan motor in the CNC control section may be faulty.

**NOTE**

See Chapter 2 for descriptions of the location of the alarm LED “CCPUALM”.

## E.3 7-SEGMENT LED INDICATIONS (BLINKING)

Table E.3 (a)

LED Display	Meaning
	Action
	ROM PARITY error The FROM/SRAM module may be faulty.
	An FROM file for program memory cannot be created. The state of the file for program memory on the FROM is checked with the BOOT system. Rearrange the FROM. Check the FROM size.
	Software-detected system alarm If it is generated during startup: Use BOOT to check the state of the built-in software in FROM, and check the size of DRAM. In other cases: Check the error on the alarm screen and take corrective action.
	The DRAM/SRAM/FROM ID is invalid. (BOOT system, NC system) The CPU card or the FROM/SRAM module may be faulty.
	A servo CPU timeout occurred. Check the state of servo software on the FROM with the BOOT system. The servo card or the additional axis board may be faulty.
	An error occurred when embedded software is incorporated. Check the state of embedded software on the FROM with the BOOT system.
	The indicator cannot be recognized. The display may be faulty.
	Hardware-detected system alarm Check the error on the alarm screen and take corrective action.
	Software for optional boards could not be loaded. Check the state of software for optional boards on the FROM with the BOOT system.
	An error occurred in waiting for an optional board. The option board or the PMC module may be faulty.
	The BOOT FROM was updated. (BOOT system) Turn on the power again.
	DRAM test error The CPU card may be faulty.
	The ID of the indicator is invalid. Check the indicator.
	The ID of the BASIC system software does not match that of the hardware. Check the combination of the BASIC system software and the hardware



# F MAINTENANCE OF PERSONAL COMPUTER FUNCTIONS (BOOT-UP AND IPL)

Appendix F, "MAINTENANCE OF PERSONAL COMPUTER FUNCTIONS (BOOT-UP AND IPL)", consists of the following sections:

F.1 OVERVIEW .....	767
F.2 CHANGING START SEQUENCES .....	769
F.3 EXPLANATION OF SCREENS .....	770
F.3.1 BOOT Screen .....	770
F.3.2 IPL Screen .....	773
F.4 OTHER SCREENS .....	774
F.4.1 CNC Alarm Screen.....	774
F.4.2 Status Screen (Personal Computer Functions with WindowsXP only).....	775
F.4.3 Option Setting Screen.....	775

## F.1 OVERVIEW

If the CNC is connected with a PC via HSSB using the PC functions in the CNC, Ncboot32.exe can be used for the maintenance of the CNC.

### NOTE

When the CNC is connected to the PC over Ethernet, use the standard LCD/MDI or Ethernet display function (see Appendix H) for the maintenance of the CNC.

Unless otherwise specified, the following examples assume the use of Ncboot32.exe of the Personal Computer Functions with WindowsXP.

Ncboot32.exe provides the following functions:

- BOOT screen (for CNC user data maintenance, SRAM backup, and so forth)
- IPL screen (for clearing SRAM, and so forth)
- Display of the CNC power-on screen
- Display of CNC alarm screen
- Re-connection in case of the occurrence of a communication error
- Start of a registered application program
- Automatic display of the BOOT/IPL screen during the next startup of the CNC (Personal Computer Functions with WindowsXP only)
- Saving and restoration of auto backup data (Personal Computer Functions with WindowsCE only)

For Personal Computer Functions with WindowsXP, Ncboot32.exe is copied to the System 32 folder of Windows during driver installation.

In addition, for Personal Computer Functions with WindowsCE, it has been installed in the Storage Card\FANUC folder.

At the start of Windows, Ncboot32.exe starts automatically, and resides in the system tray.

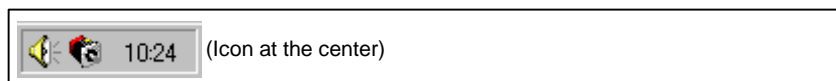

Fig. F.1 (a)

Supplementary 1: Multi-connection (Personal Computer Functions with WindowsXP only)

Ncboot32.exe supports HSSB multi-connection. The CNCs connected by HSSB are managed as nodes. The boot, IPL, and system alarm screens are displayed in windows that are opened independently for each node.

Supplementary 2: Termination method

Normally, Ncboot32.exe need not be terminated. If you need to terminate it, however, see the "System tray" explanation, below: Display the popup menu and select "End".

When the Ncboot32.exe window is open, End cannot be selected.

**System tray (Personal Computer Functions with WindowsXP)**

Right-click the icon in the system tray, and the popup menu, shown below, appears at the lower left corner of the screen.

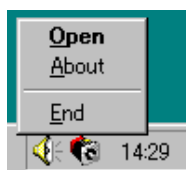

Fig. F.1 (b)

Selecting [Open] causes the status screen to open.

Selecting [About] causes the version information dialog box to appear.

Selecting [End] causes Ncboot32.exe to terminate.

Double-clicking the icon in the system tray causes Open in the menu to be automatically selected.

**System tray (Personal Computer Functions with WindowsCE)**

Keep tapping the icon in the system tray for one second or longer, and the popup menu, shown below, appears at the lower left corner of the screen.

For equipment without a touch panel, the popup menu can be displayed by restarting "\Storage Card\FANUC\Ncboot32.exe" with the icon having been registered in the system tray.

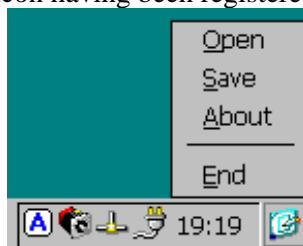

Fig. F.1 (c)

Selecting [Open] causes the option setting screen to open.

Selecting [Save] causes the contents of the Registry to be stored and causes the registered files to be saved in the "\Storage Card\Backup" folder. If auto backup fails, the files in this folder are used for recovery.

Selecting [About] causes the version information dialog box to appear.

Selecting [End] causes Ncboot32.exe to terminate.

Double-clicking the icon in the system tray causes Open in the menu to be automatically selected.

**NOTE**

Depending on when to tap, the popup menu may not be displayed normally. If this occurs, repeat tapping until it is displayed normally.

## F.2 CHANGING START SEQUENCES

By pressing the MDI keys 6 and 7 and turning the power ON or by setting the rotary switch provided on the main board of the CNC main unit (for the stand-alone type CNC or LCD-mounted type CNC) to the F position, you can perform maintenance work using the BOOT and IPL screens.

During normal operation

1. The CNC starts without waiting for communication to be established.
2. The PC waits to be connected to the CNC for communication.
3. Initialize a work area for the FOCAS2 library.
4. Start a registered application program.
5. Perform monitoring for communication errors and CNC system alarms.

During maintenance

1. Wait until communication with the CNC is established.
2. Display the boot screen.
3. Display the IPL screen.
4. Display the CNC power-on screen.
5. Initialize a work area for the FOCAS2 library.
6. Start a registered application program.
7. Perform monitoring for communication errors and CNC system alarms.

- **Location of rotary switch**

- LCD-mounted type CNC

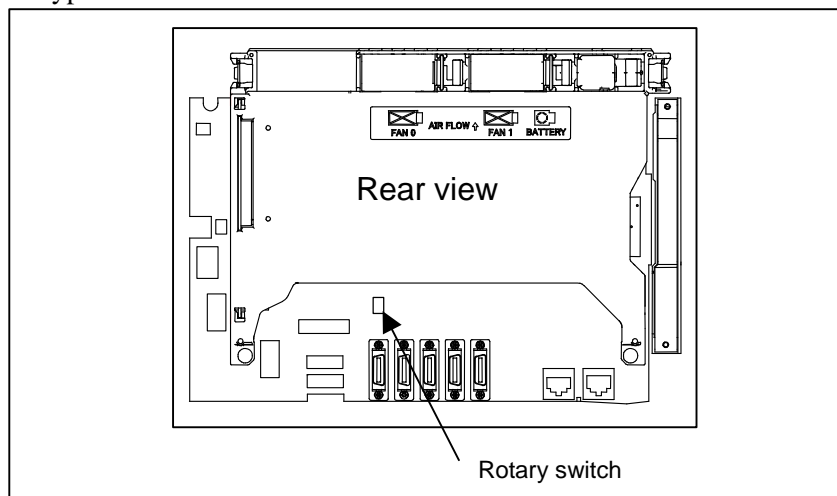

Fig. F.2 (a)

- Stand-alone type CNC

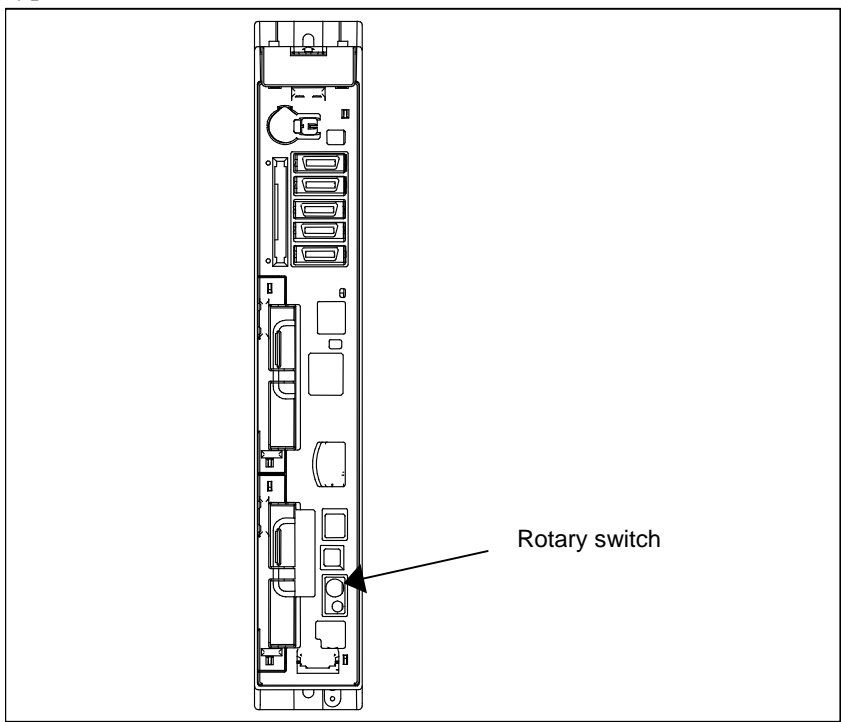

Fig. F.2 (b)

## F.3 EXPLANATION OF SCREENS

**NOTE**

To open each screen of Ncboot32.exe, you are recommended to use either the mouse or touch panel.

### F.3.1 BOOT Screen

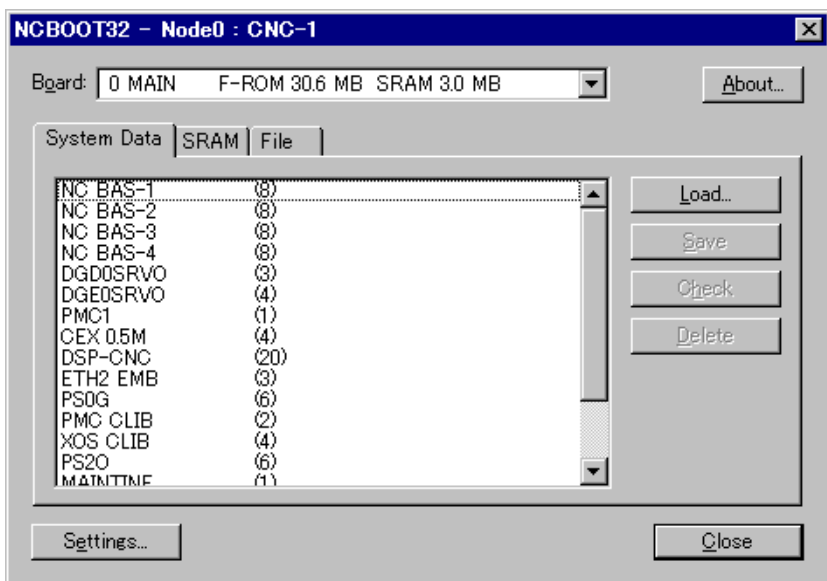

Fig. F.3 (a)

The area where the file is to be placed can be changed by using the [Setting...] button.

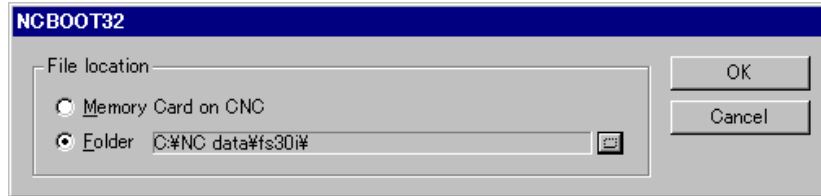

Fig. F.3 (b)

Select the memory card on the CNC or the folder on a personal computer. The file location may be changed at any time.

**"Memory Card on CNC":** Specify the memory card slot of the CNC.

1. LCD-mounted type CNC : Beside the display unit
  2. Stand-alone type CNC (without a display unit) : Control unit
  3. Stand-alone type CNC (with a display unit) : Beside the display unit
- (The display unit represents a LCD unit with no PC functions.)

**"Folder":** Specify a folder on the PC.

To use the memory card slot beside PANEL i, select "Folder" and specify the drive name given to the memory card by Windows.

### F.3.1.1 User data manipulation

The following screen is used for manipulating user data (including ladder programs and macro programs) on the NC.

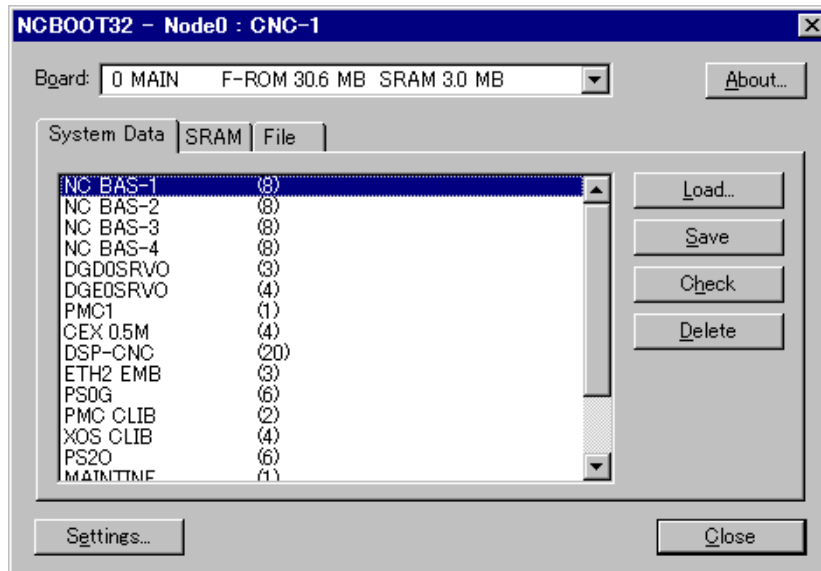

Fig. F.3 (c)

[Load...] opens the file selection screen. Specify a file to be loaded.

[Save] saves the selected NC user data in a file.

[Check] checks the contents of the selected NC system data or user data.

[Delete] deletes the selected NC user data.

#### NOTE

It is impossible to load, save, or delete system data.

### F.3.1.2 SRAM operation

This screen is used to store and restore NC SRAM data.

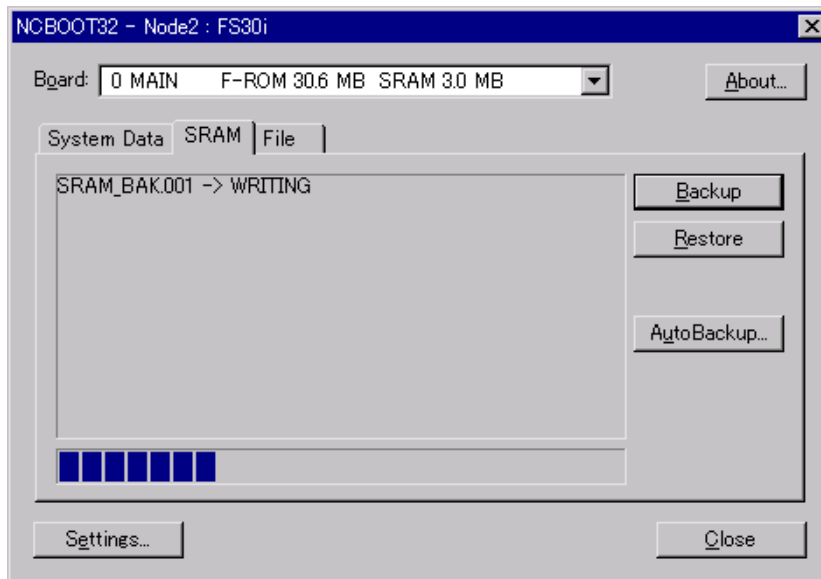

Fig. F.3 (d)

**[Backup]:** Saves SRAM data to a file.

**[Restore]:** Restore SRAM data from a file.

The progress of the operation is indicated in the lower part of the screen. The name of the backup file is automatically determined according to the SRAM size and cannot be changed.

The CNC has the function of automatically saving the data of SRAM in FROM. The personal computer can restore the data that was saved automatically to SRAM. Press the **[AutoBackup...]** button to display the following screen.

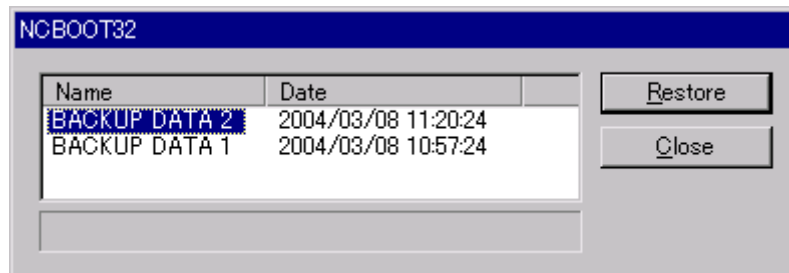

Fig. F.3 (e)

Select a saved image under "Name" and press the **[Restore]** button to restore the SRAM data of the CNC.

### F.3.1.3 File operation

The following screen is used for operating files on a memory card in the CNC or in a folder of the personal computer.

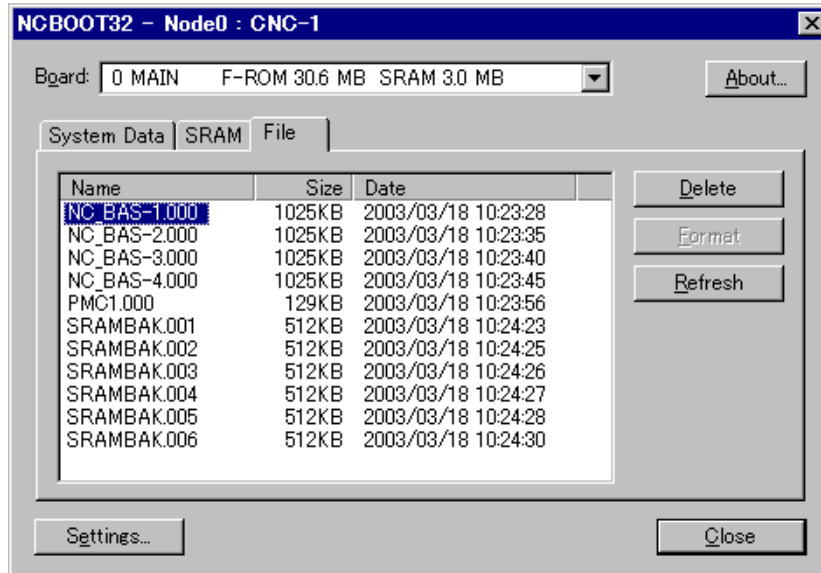

Fig. F.3 (f)

[Delete] deletes a selected file.

[Format] formats the memory card. This button is valid when the memory card is selected by [Setting...]

[Refresh] updates the file list to the latest state. After changing memory cards or floppy disks, click this button.

### F.3.2 IPL Screen

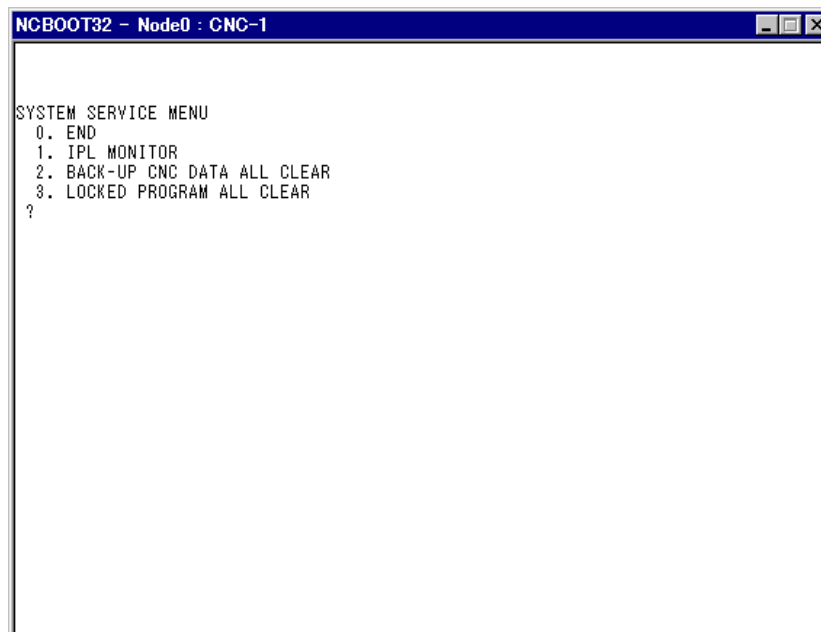

Fig. F.3 (g)

**NOTE**

The contents of the IPL screen vary depending on the CNC model. Follow the instructions displayed in the menu.

**F.3.2.1 Functions on the IPL screen**

The CNC allows functions to be performed according to the key status set at power-on. No power-on time key operation can be performed with the personal computer function with Windows XP or the personal computer function with Windows CE. Instead, the equivalent function on the IPL screen can be executed. For details of the menu on the IPL screen and supported functions, see the table given in Section F.3.2.1.

Table F.3 (a)

Title on IPL screen	Corresponding MDI key operation at power-on (Operation with a standard CNC)
0. EXIT	
1. IPL MONITOR	<-> + <. >
2. BACK-UP CNC DATA ALL CLEAR	<DELETE> + <RESET>
3. LOCKED PROGRAM ALL CLEAR	<M> + <O>

**F.4 OTHER SCREENS**

**F.4.1 CNC Alarm Screen**

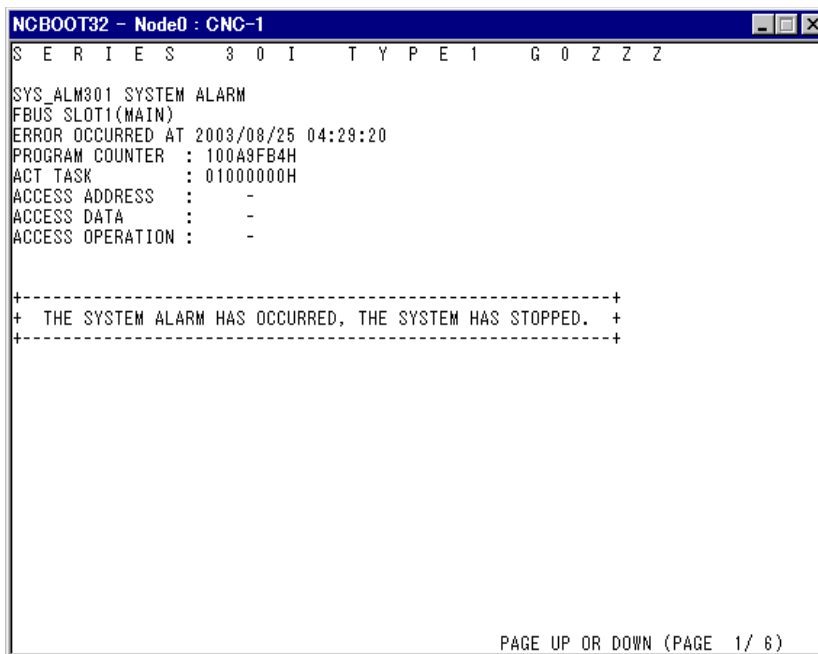

Fig. F.4 (a)

This screen appears when a system alarm is issued in the CNC. (The above screen is an example. The displayed information varies depending on the system alarm issued in the CNC.)



## F.4.2 Status Screen (Personal Computer Functions with WindowsXP only)

To open the status screen, double-click the icon in the system tray. Alternatively, in the menu popped up by right-clicking, click "Open".

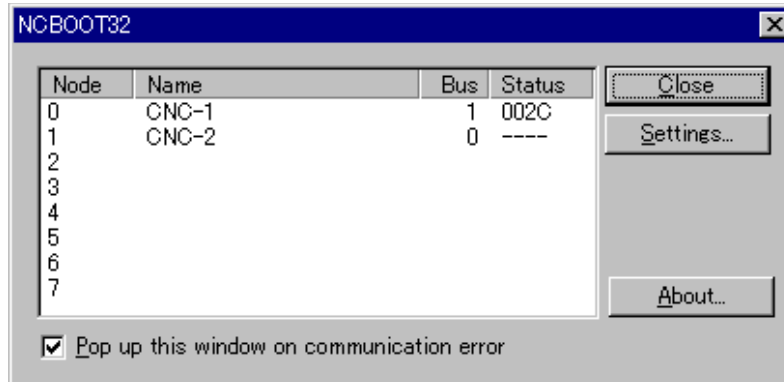

Fig. F.4 (b)

- Node: Node number  
 Name: Node name. (Define the node name in advance by using the HSSB applet on the control panel.)  
 Bus: Hardware communication status (0: Communication error, 1: Communication established)  
 Status: Status (in hexadecimal)
- Bit 2: End of boot processing
  - Bit 3: End of IPL processing
  - Bit 4: Rotary switch position 0
  - Bit 5: Display of 30 lines on IPL/system alarm screen
  - Bit 7: Internal flag
  - Bit 8: CNC system alarm
  - Bit 9: Internal flag
  - Bit 10: Internal flag

Pop up this window on communication error: By checking this item, this screen is opened automatically when a communication error occurs.

Clicking the [Close] button closes the screen.

Clicking the [Setting...] button opens the option setting screen.

Clicking the [About...] button opens the version information screen.

### NOTE

The Personal Computer Functions with WindowsCE does not provide a status screen.

## F.4.3 Option Setting Screen

On the option setting screen, application programs can be registered.

Any programs for use with FOCAS2 will not run unless they are started after communication establishment with CNC. By registering these programs in Ncboot32.exe, they can be executed in synchronization with the start of FOCAS2.

For the Personal Computer Functions with WindowsCE, it is possible to perform auto backup and configure MDI keys.

### F.4.3.1 Option setting screen (Personal Computer Functions with WindowsXP)

Clicking the [Settings...] button on the status screen causes the option setting screen to open. On the option setting screen, an application must be registered with each node that requires it. In addition, it is possible to set the display of the BOOT/IPL screen during the next startup of the CNC.

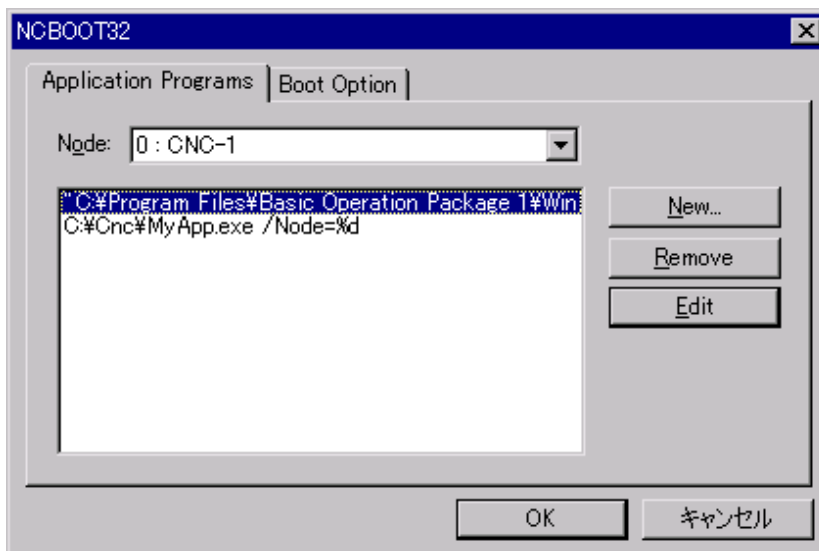

Fig. F.4 (c)

[Node] selects a node. In the list box in the center of the screen, the programs registered for the selected node are displayed.

[New...] registers a new program. When a blank character is included in the path, it is enclosed with double quotation marks.

[Remove] deletes a selected line.

[Edit] allows editing of a selected line. This button is used to edit arguments. The character string %d in the command line is replaced by a node number. To represent % itself, describe %%.

Example: To start the CNC screen display function after FOCAS2 starts at that node, code the following:  
 "C:\Program Files\CNCScreen\CNCScr.exe" /Node=%d

To set the display of the BOOT/IPL screen during the next startup of the CNC, select the "**Boot Option**" tab on the option setting screen.

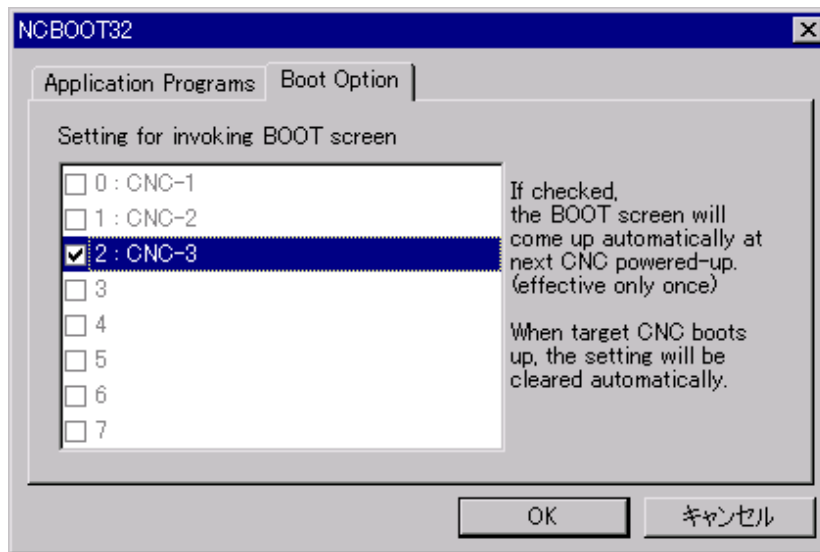

Fig. F.4 (d)

If a CNC that is not grayed out is checked, the BOOT/IPL screen appears during the next startup of the CNC, regardless of the setting of the rotary switch on the CNC side. This display setting is enabled only once and automatically cleared by Ncboot32.exe.

### F.4.3.2 Option setting screen (Personal Computer Functions with WindowsCE)

To open the option setting screen, double-tap the icon in the system tray. Alternatively, select [Open] from the popup menu of the system tray.

#### NOTE

For any changes made on the option setting screen of the Personal Computer Functions with WindowsCE to take effect, you must turn the power off and back on.

### CNC setting screen

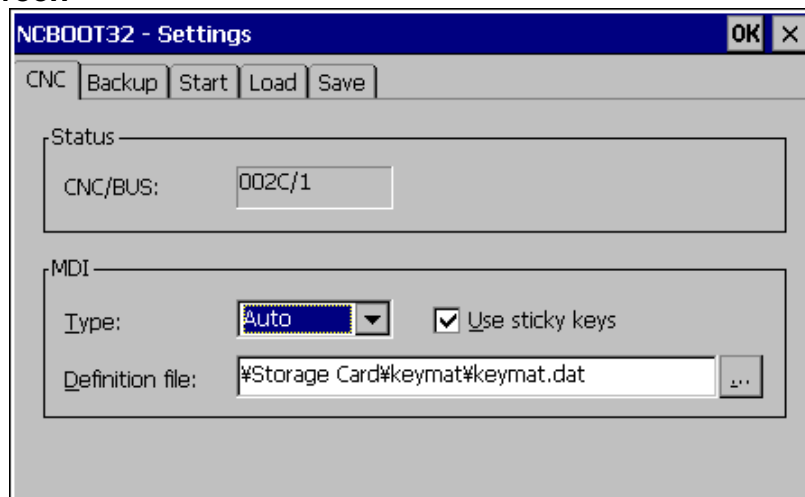

Fig. F.4 (e)

- [Status]-[CNC] : Status (in hexadecimal)
  - Bit2 : End of boot processing
  - Bit3 : End of IPL processing
  - Bit4 : Rotary switch position 0
  - Bit5 : Display of 30 lines on IPL/system alarm screen
  - Bit7 : Internal flag
  - Bit8 : CNC system alarm
  - Bit 9: Internal flag
  - Bit 10: Internal flag
- [Status]-[Bus] : Hardware communication status (0: Communication error, 1: Communication established)

[MDI]-[Type] allows you to select an MDI key type.

- Auto: QWERTY MDI key type, M and T series standard MDI key type
- M series : MDI keyboard for M series
- T series : MDI keyboard for T series

Selecting [MDI]-[Use sticky keys] allows you to use the functions of the Shift, Ctrl, and Alt keys without pressing these keys in combination with other keys. For example, you can press Alt first and then 'F' instead of pressing Alt and 'F' at the same time. If you remove the check mark, you must press Alt and 'F' at the same time.

[MDI]-[Definition file] allows you to specify a customized MDI key definition file.

### Device setting screen

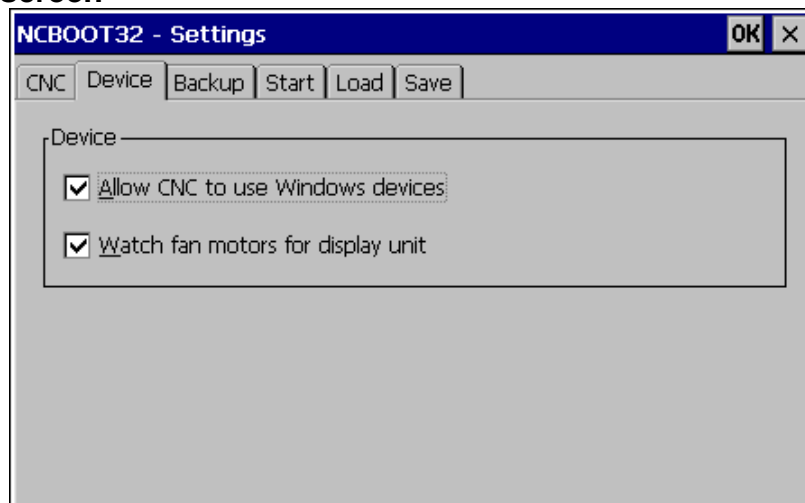

Fig. F.4 (f)

Place a check mark next to [Allow CNC to use Windows devices] to make the devices on Windows (Ethernet, serial, and PCMCIA devices) usable by the CNC.

Place a check mark next to [Watch fan motors for display unit] to check the operation of the display unit of the stand-alone type CNC; if an error is detected, an error message is displayed.

## Backup setting screen

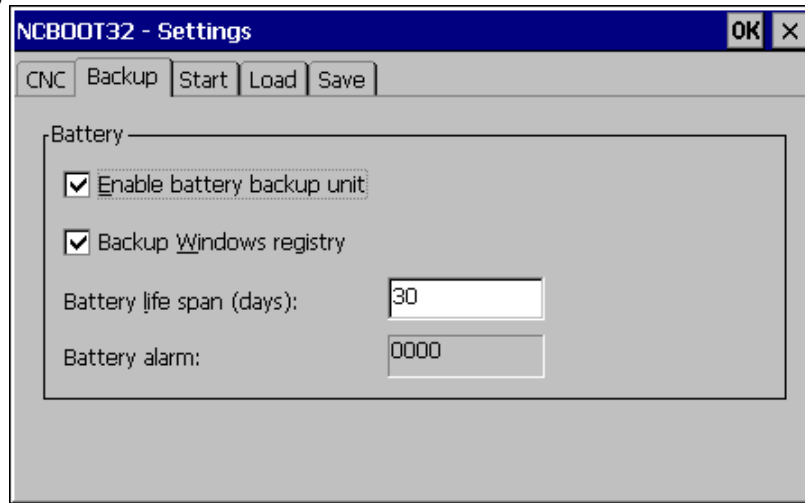

Fig. F.4 (g)

Place a check mark next to [Enable battery backup unit] to automatically save the contents of the Registry and files when the power is turned off. A dedicated battery is used to supply power during a saving operation after the power is turned off.

Place a check mark next to [Backup Windows registry] to automatically save the contents of the Registry when the power is turned off.

### NOTE

Usually, the contents of the Registry are not changed and, therefore, no problems will arise if they are not automatically saved. You are recommended to remove the check mark next to Auto saving of Registry just in case.

[Battery life span] allows you to set the number of days after which a message prompting you to save manually is to be displayed during long-period operation.

[Battery alarm] indicates the state of the battery dedicated for backup (in hexadecimal notation).

- 0000 : Normal
- 0001 : The previous auto saving not completed
- Other : Battery hardware error value

## Start/Load/Save setting screen

This screen allows you to edit save, restore, and start files and to check execution results. Start allows you to select the file to be started when the power is turned on. Save allows you to select the file to be saved when the power is turned off. Load allows you to select the file to be restored when the power is turned on.

The following shows the Save screen as an example. The screen layout and the main operating instructions are common to the Start, Load, and Save screens.

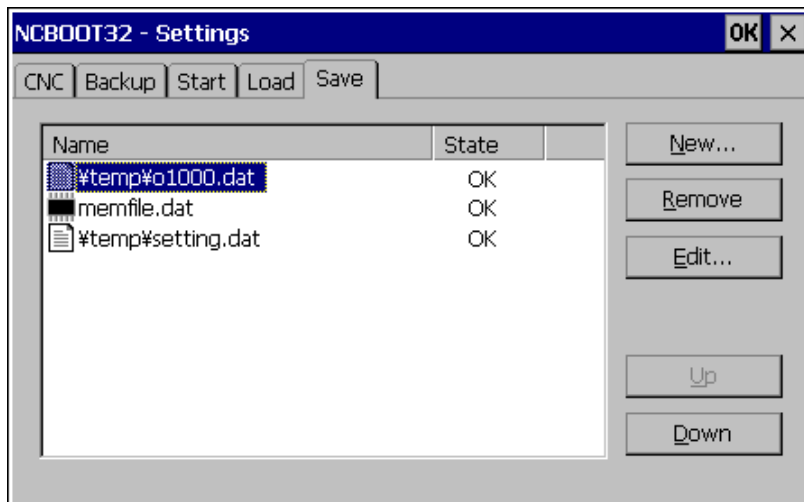

Fig. F.4 (h)

The [New...] button is used to register a new file.  
 The [Remove] button allows you to cancel the registration of the selected line.  
 The [Edit...] button allows you to change the changes made with the [New...] button.  
 The [Up] button is used to move a selected line up in the registration sequence.  
 The [Down] button is used to move a selected line down in the registration sequencer.

Pressing the [New...] button causes the following dialog box to appear, allowing you to specify a file.

- Start screen

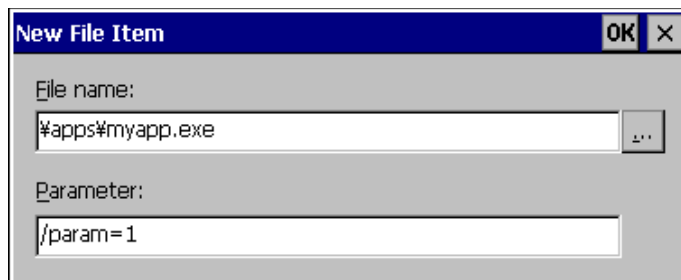

Fig. F.4 (i)

In the [File name] field, specify a full path name of the file to be executed.  
 In the [Parameter] field, specify the program argument.

- Load/Save screen

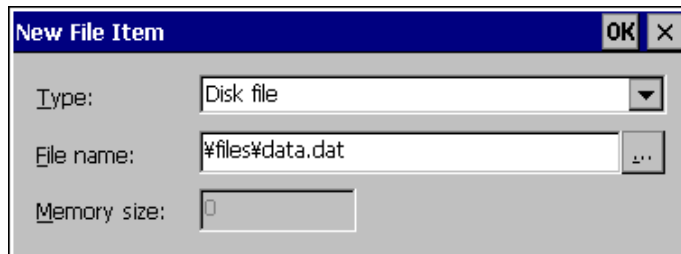

Fig. F.4 (j)

[Type] is used to specify whether the file is on the Disk (object store) or it is a memory mapped file.  
 In the [File name] field, specify the full path name if the file is on the Disk; specify the name of the file mapping object if it is a memory mapped file.

**NOTE**

The name of a file mapping object is used as a temporary file for use during saving and restoration. You must, therefore, specify a string characters effective as a file name.

In the [Memory size] field, specify the size of the memory mapped file. For a file on the Disk, you need not specify the size because it is calculated from the actual file name.

# G MAINTENANCE OF STAND-ALONE TYPE UNIT

Appendix G, "MAINTENANCE OF STAND-ALONE TYPE UNIT", consists of the following sections:

G.1 OVERVIEW .....	782
G.2 OPERATION .....	782
G.3 OPERATION OF EACH FUNCTION .....	783

## G.1 OVERVIEW

### Overview

The FANUC Series 30i/31i/32i of stand-alone type has a 7-segment LED, rotary switch, and push switch. When there is no MDI or MDI cannot be used due to a malfunction, battery backed-up data can be saved or restored if the rotary switch and push switch are operated.

#### NOTE

When MDI is available, use maintenance operation of the BOOT function.

### Layout of the 7-segment LED and switches

The 7-segment LED, the rotary switch, and the push switch are located as shown in the Fig. G.1 (a):

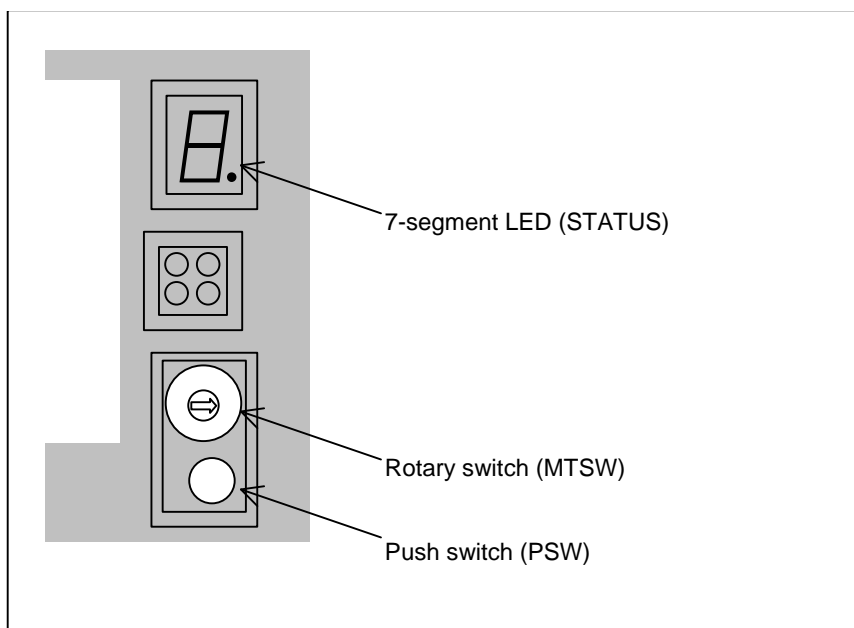

Fig. G.1 (a)

## G.2 OPERATION

### Operation before power-on

Before turning on the power, select a function number by using the rotary switch. When the power is turned on after the selection with the rotary switch, the number corresponding to the selected function number is indicated on the LED. The indication blinks at intervals of about one second.



### Function number

Each function is assigned a number. This number is called a function number hereinafter in this manual. The function numbers that can be selected with the rotary switch are listed below (Table G.2 (a)). Do not set the reserved function numbers.

Table G.2 (a)

Function number	Explanation
0	Normal state.
1	Set a display unit number in the Ethernet Display function.
2	Set a node number in the Ethernet Display function.
3	Reserved
4	Checks settings in the Ethernet Display function.
5	Clears all data in memory.
6	Reserved
7	Reserved
8	Saves battery backed-up main board data in a memory card at a time.
9	Reserved
A	Restores battery backed-up main board data from a memory card at a time.
B	Reserved
C	Reserved
D	Reserved
E	Does not wait for the display unit.
F	Performs maintenance work.

## G.3 OPERATION OF EACH FUNCTION

### Function number 1

This function sets a display unit number in the Ethernet Display function.

- (1) Check that number 1 blinks on the LED, and press the push switch.
- (2) If the push switch is pressed, the 16 numbers from 0 to F are displayed on the LED in sequence at one second intervals. When the display unit number to be set is displayed on the LED, press the push switch.
  - 0 : Not used.
  - 1 : The HSSB connection display unit or CNC-specific display unit is set.
  - 2 to 4 : Not used.
  - 5 : The Ethernet connection display unit is set.
  - 6 to F : Not used.
- (3) The selected display unit number blinks on the LED. Press the push switch again.
- (4) The selected display unit number is displayed on the LED and saved in the CNC.

### Function number 2

This function sets a node number in the Ethernet Display function.

- (1) Check that number 2 blinks on the LED, and press the push switch.
- (2) If the push switch is pressed, the 16 numbers from 0 to F are displayed on the LED in sequence at one second intervals. When the node number to be set is displayed on the LED, press the push switch.
 

The node number ranges from 0 to 7.
- (3) The selected node number blinks on the LED. Press the push switch again.
- (4) The node number is displayed on the LED and the display unit number is saved in the CNC.

### Function number 4

This function checks settings in the Ethernet Display function.

- (1) Check that number 4 blinks on the LED, and press the push switch.

- (2) When the push switch is pressed, 0 and 1 are displayed on the LED alternately at one second intervals. When 0 is displayed, press the push switch.
- (3) The selected number 0 blinks on the LED. Press the push switch to stop blinking.
- (4) The three numbers from 0 to 2 are displayed in sequence at one second intervals again. When the number to be checked is displayed on the LED, press the push switch.  
0 : Not used.  
1 : A display unit number is checked.  
2 : A node number is checked.
- (5) The selected number blinks. Press the push switch to stop blinking.

### Function number 5

This function clears all the battery backed-up SRAM data.

The settings of the Ethernet Display function are also cleared and the display unit number and node number are set to 1 and 0, respectively.

- (1) Check that number 5 blinks on the LED, and press the push switch.
- (2) Number 5 is displayed on the LED. Press the push switch.
- (3) Display of the LED changes in the order: "-", "F", and "0".
- (4) After all-clear operation terminates normally, the LED display stops changing at number 0.
- (5) Turn off the power, return the rotary switch to the original position, and turn on the power again.

#### WARNING

- 1 This operation enables the CNC system to start up solely (initial state). Accordingly, to recover various functional operations, the cleared data needs to be set again.
- 2 This operation can be performed by those personnel who received the training of maintenance and safety.

### Function number 8

This function saves battery backed-up main board data in a memory card at a time. The data saved using this function can be restored at a time by performing the operation for function number A or by using the SRAM DATA UTILITY function of the boot function.

- (1) Insert a memory card with enough free space into the memory card slot (MEMORY CARD CNM1B) of the main body.
- (2) Check that number 8 blinks on the LED, and press the push switch.
- (3) Number 8 is displayed on the LED. Press the push switch.
- (4) While data is saved in the memory card, display of the LED is rotating clockwise.
- (5) If the data cannot fit in one memory card, number 3 blinks. Replace the memory card with another one, and press the push switch.
- (6) If the data cannot be written to the memory card, number 2 blinks on the LED. Replace the memory card with another one and press the push switch.
- (7) When the data has been saved normally, number 0 is displayed on the LED. If the data cannot be saved normally, number 1 is displayed on the LED.
- (8) If the data cannot be backed up because it is illegal, number 1 blinks on the LED. In this case, it is impossible to save the data at a time. Back up individual data items one by one, then perform all-clear operation.

### Function number A

This function restores battery backed-up main board data from a memory card at a time.

- (1) Insert the memory card in the memory card slot (MEMORY CARD CNM1B) of the control unit.
- (2) Check that A blinks on the LED, and press the push switch.
- (3) When letter A is displayed on the LED, press the push switch.
- (4) While data is being restored from the memory card, the LED indication turns counterclockwise.

- (5) If the entire data cannot be restored from the single memory card, number 3 blinks. Replace the memory card with the next memory card, and press the push switch.
- (6) If the memory card cannot be recognized correctly, number 2 blinks on the LED. Check the memory card status, and press the push switch.
- (7) When the data has been restored normally, number 0 is displayed on the LED. If the data cannot be restored normally, number 1 is displayed on the LED.

**Function number E**

This setting does not wait for the display unit. Use this setting for a configuration without a display unit.

# H ETHERNET DISPLAY FUNCTION

Appendix H, "ETHERNET DISPLAY FUNCTION", consists of the following sections:

H.1 OVERVIEW .....	786
H.2 EXAMPLE OF NETWORK CONFIGURATION .....	787
H.3 DISPLAY UNIT NUMBER SETTING AND CONFIRMATION.....	790
H.3.1 Display Unit Number Setting .....	790
H.3.2 Display Unit Number Confirmation .....	791
H.4 NODE NUMBER SETTING AND CONFIRMATION .....	792
H.4.1 Method of Node Number Setting .....	792
H.4.2 Method of Node Number Confirmation .....	792
H.5 CHANGING START SEQUENCES .....	793
H.6 NCBOOT32E.exe .....	794
H.6.1 Boot Screen.....	795
H.6.2 File Storage Location Selection.....	796
H.6.3 User Data Operation .....	796
H.6.4 S-RAM Operation.....	797
H.6.5 File Operation .....	798
H.6.6 IPL Screen .....	799
H.6.7 CNC Alarm Screen.....	800
H.6.8 Status Screen.....	800
H.6.9 Option Setting Screen .....	801
H.6.10 Changer Screen.....	802
H.7 STARTING OF THE CNC SCREEN DISPLAY FUNCTION.....	803

## H.1 OVERVIEW

Up to eight CNCs of stand-alone type and one PANEL *i* unit (which may be hereinafter referred to as a personal computer) can be connected with each other via Ethernet to use the personal computer as a display unit for the CNCs.

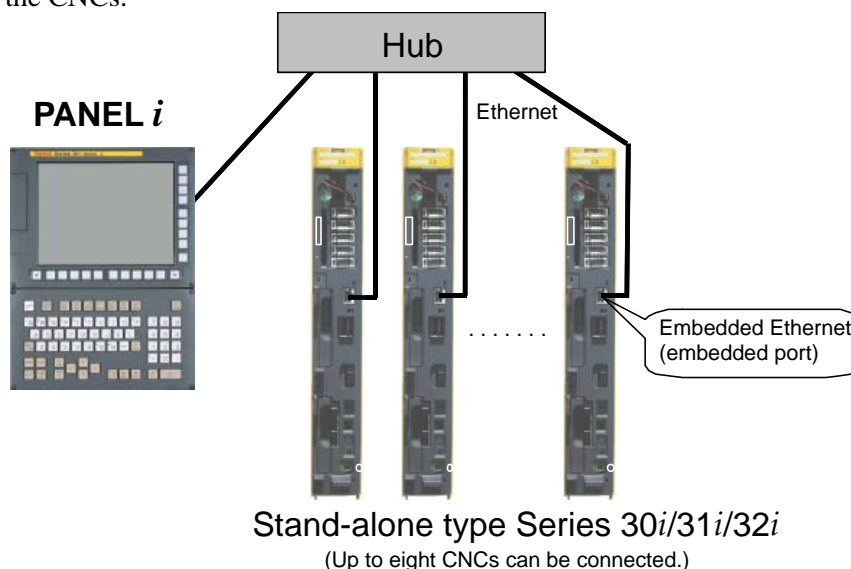

Fig. H.1 (a)

- CNC screens that can be displayed and operated by Ethernet Display function
  - CNC screen for maintenance (NCBOOT32E.exe)
    - Display and operation of the boot screen
    - Display and operation of the IPL screen
    - Display of the CNC power-on screen
    - Display of the CNC alarm screen
  - CNC screen for normal operation (CNCScrnE.exe)
    - Display and operation of the general CNC screen
- Number of connectable CNCs
  - Up to eight CNCs can be connected to one personal computer.
- Ethernet address setting
  - The IP address of a CNC is the half-fixed address 192.168.1.(10+N) [from 192.168.1.10 to 192.168.1.17]. The value of N at the end is set using a rotary switch. The IP address of the personal computer needs to be fixed at 192.168.1.200.  
The TCP port numbers 8193 and 8198 are used for the CNCs, and the UDP port number 8197 is used for the personal computer. (No port number needs to be set.)
  - When Ethernet Display function option is not selected, the IP address of a CNC connectable to the personal computer is 192.168.1.10 only.

**NOTE**

- 1 When using Ethernet Display function, note the following:
  - The screen update interval of Ethernet Display function is longer than that of a CNC-dedicated display unit. Even when a higher-performance personal computer is used, the screen update interval cannot be made shorter than that of a CNC-dedicated display unit.
  - When high-load machining such as high-speed and high-precision machining is performed, Ethernet Display function is more affected than a CNC-dedicated display unit, so a longer screen update interval may result.
  - As described in Appendix H.2, "EXAMPLE OF NETWORK CONFIGURATION", Ethernet Display function is designed for a system where multiple machines share a display unit or a system that does not need a display unit usually. For example, when using a machine that the machine operator operates by displaying and operating the CNC screen at all times as in the case of using MANUAL GUIDE *i*, use a CNC-dedicated display unit.
- 2 Only CNCs of stand-alone type can be used.
- 3 When Ethernet Display function is used, the PCMCIA Ethernet card cannot be used. When using FANUC LADDER-III and SERVO GUIDE, use the embedded port (Ethernet connector (CD38A) on the control unit).
- 4 Ethernet Display function cannot be operated with Fast Ethernet board.
- 5 When Ethernet Display function is used, the HSSB connection needs to be cleared or the CNC-dedicated display unit needs to be disconnected.
- 6 For a personal computer (or PANEL *i*), select a CPU and memory size that can sufficiently handle the connected CNCs and application software used. When multiple CNCs are used, it is recommended to select Pentium III (866 MHz or higher) for the CPU and a memory of 256 MB or more.
- 7 When PANEL *i* is used, the USB interface QWERTY MDI, FA full keyboard, or general full keyboard is required. Refer to "FANUC PANEL *i* CONNECTION AND MAINTENANCE MANUAL (B-64223EN)".

**NOTE**

- 8 When Ethernet Display function is used, the DHCP client function is automatically disabled.
- 9 In a personal computer environment based on Windows XP Service Pack 2 or later, a security warning screen as shown Fig. H.1 (b) is displayed when Ethernet Display function is used for the first time. Select "Unblock".



Fig. H.1 (b)

## H.2 EXAMPLE OF NETWORK CONFIGURATION

### Example 1: When multiple CNCs share a display unit

PANEL *i* is shared as a display unit by five CNCs.

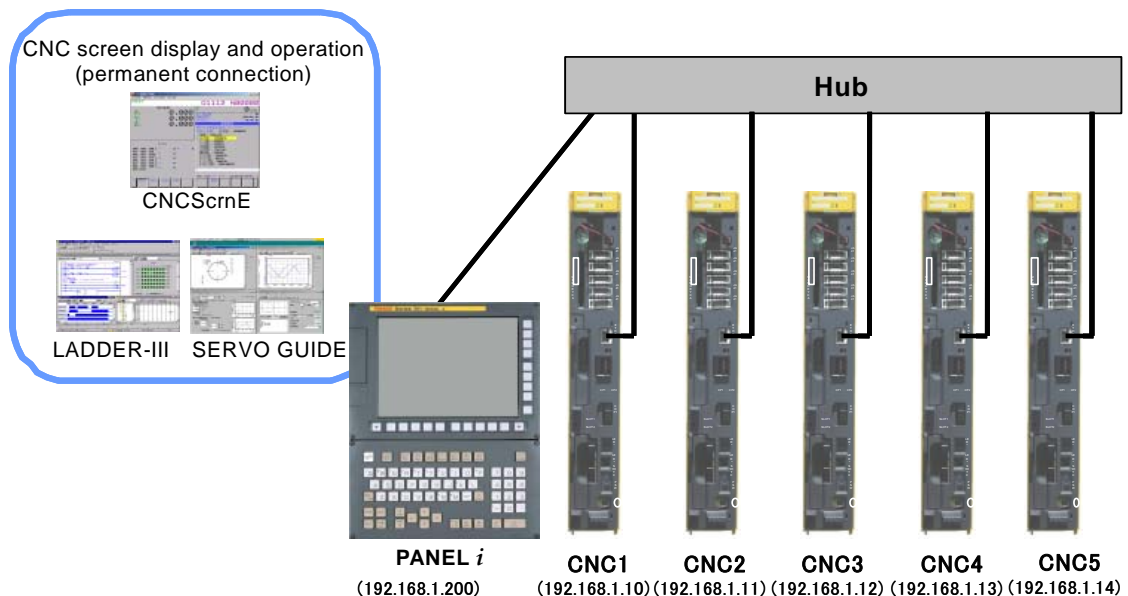

Fig. H.2 (a)

The software option required for this configuration is indicated below.

- 1 Ethernet Display function (-R950)
- 2 CNC Screen Display function (A02B-0207-J858)

### Example 2: When no display unit is required

No display unit is required usually. However, a notebook personal computer is connected as a display unit to a CNC for maintenance.

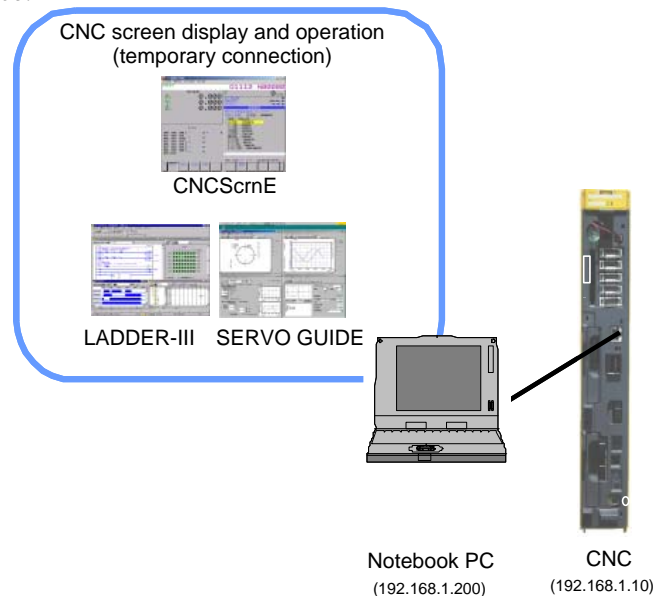

Fig. H.2 (b)

The software option required for this configuration is indicated below.

- 1 Ethernet Display function (-R950)
- 2 CNC Screen Display function (A02B-0207-J858)

#### NOTE

When a personal computer and CNC are connected with each other on a one-to-one basis, the optional Ethernet Display function may not be selected. In this case, the node number is fixed at "0" (IP address: 192.168.1.10).

### Example 3: When a connection is made with a factory network

Personal computer 1 is connected to hub 1 as a display unit for CNC1, CNC2, and CNC3. Personal computer 2 is connected to hub 2 as a display unit for CNC4, CNC5, and CNC6. To communicate with personal computer 3 on the factory network, a Fast Ethernet board is added to each CNC, and personal computer 3 and all CNCs are connected to hub 3.

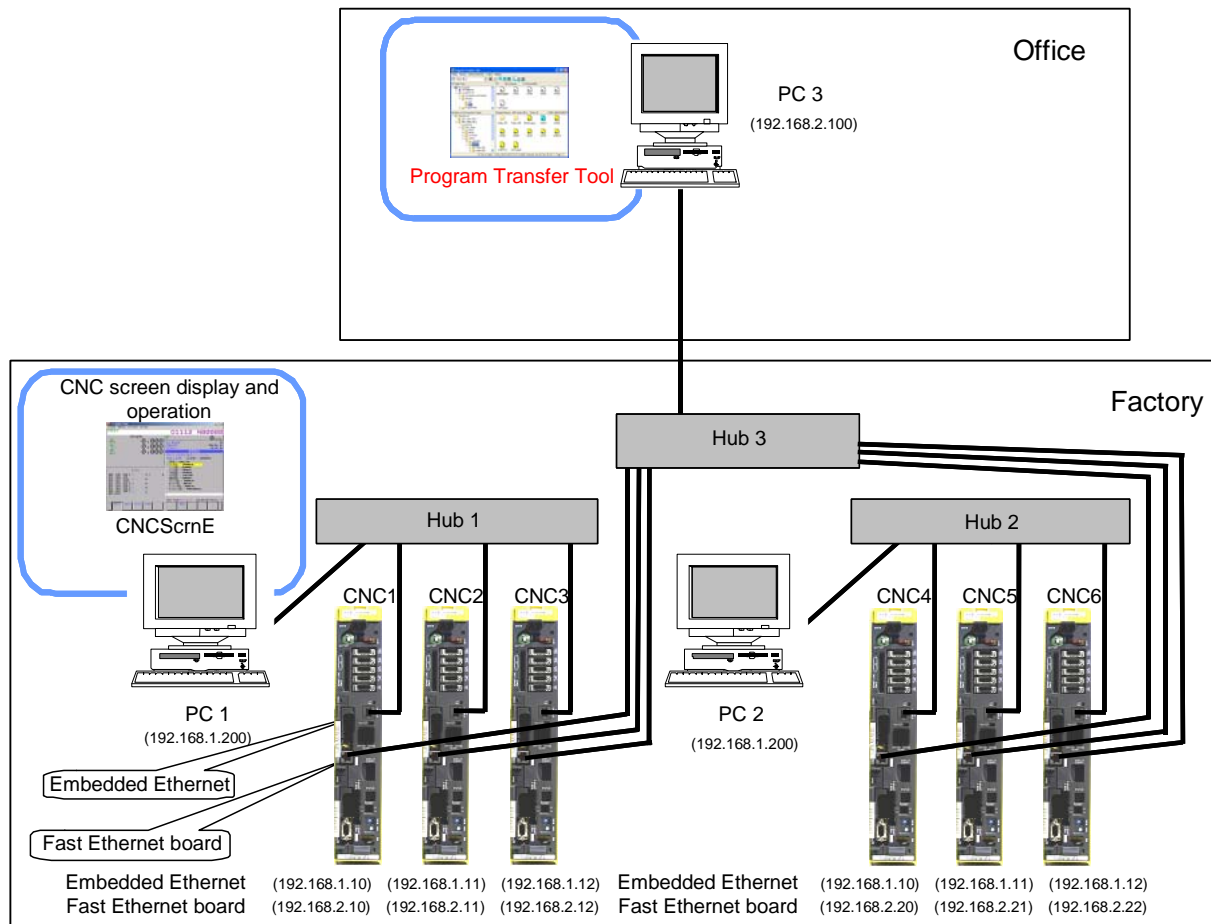

Fig. H.2 (c)

**NOTE**

The basic network configuration based on Ethernet Display function consists of only CNCs and a personal computer for display. If the network has a personal computer to which CNCs do not communicate, CNC communication processing load increases, and the display speed can slow down. So, avoid connecting with the network at the whole factory. However, when a personal computer is to be connected temporarily for a purpose other than display, the personal computer can be connected to the network by satisfying the IP address system above.

## H.3 DISPLAY UNIT NUMBER SETTING AND CONFIRMATION

To use Ethernet Display function, set the display unit number to "5" (Sets the display unit for Ethernet connection) with the rotary switch.

### H.3.1 Display Unit Number Setting

Set the rotary switch to **"1" (Function number 1)** then turn on the power to the CNC. Next, perform the operation below to set the display unit number.

**Function number 1**

- (1) Check that "1" is blinking on the 7-segment LED then press the push switch.



- (2) Each of the sixteen numbers "0" to "F" is displayed on the 7-segment LED at intervals of about one second. When "5" is displayed, press the push switch.
- (3) On the 7-segment LED, "5" blinks.  
The display unit numbers are defined as follows:
 

0	: Not used
1	: Sets the display unit as a display unit connected to HSSB or a CNC-dedicated display unit.
2 to 4	: Not used
5	: Sets the display unit for Ethernet connection.
6 to F	: Not used
- (4) Press the push switch again. The blinking stops and the display unit number "5" is saved to the CNC.
- (5) Set the rotary switch to a proper position according to Appendix H.5, "START SEQUENCE SWITCHING". Next, turn off the CNC then turn on the CNC again.

**CAUTION**

Never turn off the power to the CNC until steps (1) through (4) above for display unit number setting are completed.

## H.3.2 Display Unit Number Confirmation

Two methods of confirming the currently set display unit number are available as described below.

### Confirming the display unit number at power-on

Set the rotary switch to "4" (**Function number 4**) then turn on the power to the CNC. Next, perform the operation below to confirm the display unit number.

#### Function number 4

- (1) Check that "4" is blinking on the 7-segment LED then press the push switch.
- (2) Each of the two numbers "0" and "1" is displayed on the 7-segment LED at intervals of about one second. When "0" is displayed, press the push switch.
- (3) On the 7-segment LED, "0" blinks.
- (4) Press the push switch again. Each of the three numbers "0" through "2" is displayed on the 7-segment LED at intervals of about one second. When "1" is displayed on the 7-segment LED, press the push switch.
- (5) On the 7-segment LED, "1" blinks.
- (6) Press the push switch once more. The blinking stops and the display unit number saved to the CNC is displayed. Check that the display unit number "5" is set.
- (7) Set the rotary switch to a proper position according to Appendix H.5, "START SEQUENCE SWITCHING". Next, turn off the CNC then turn on the CNC again.

### Confirming the display unit number in normal operation

When the CNC is performing normal operation, the display unit number blinks on the 7-segment LED while the push switch is held down with the rotary switch set to "2".

**NOTE**

Upon completion of display unit number confirmation, be sure to return the rotary switch to the previous position.

## H.4 NODE NUMBER SETTING AND CONFIRMATION

With Ethernet Display function, a node number needs to be set to determine the value of N at the end of IP address 192.168.1.(10+N) of a CNC.

### H.4.1 Method of Node Number Setting

Set the rotary switch to **"2" (Function number 2)** then turn on the power to the CNC. Next, perform the operation below to set a node number.

#### Function number 2

- (1) Check that "2" is blinking on the 7-segment LED then press the push switch.
- (2) Each of the sixteen numbers "0" through "F" is displayed on the 7-segment LED at intervals of about one second. When a node number to be set is displayed on the 7-segment LED, press the push switch.

#### NOTE

The numbers "0" through "F" are displayed. Note, however, that a number within the range 0 to 7 needs to be selected.

- (3) The node number to be set blinks on the 7-segment LED.
- (4) Press the push switch again. The blinking stops and the node number is saved to the CNC.
- (5) Set the rotary switch to a proper position according to Appendix H.5, "START SEQUENCE SWITCHING". Next, turn off the CNC then turn on the CNC again.



#### CAUTION

Never turn off the power to the CNC until steps (1) through (4) above for node number setting are completed.

#### NOTE

Set a node number that does not duplicate the node number of another CNC.

### H.4.2 Method of Node Number Confirmation

Two methods of confirming the currently set node number are available as described below.

#### Confirming the node number at power-on

Set the rotary switch to **"4" (Function number 4)** then turn on the power to the CNC. Next, perform the operation below to confirm the node number.

#### Function number 4

- (1) Check that "4" is blinking on the 7-segment LED then press the push switch.
- (2) Each of the two numbers "0" and "1" is displayed on the 7-segment LED at intervals of about one second. When "0" is displayed, press the push switch.
- (3) On the 7-segment LED, "0" blinks.
- (4) Press the push switch again. Each of the three numbers "0" through "2" is displayed on the 7-segment LED at intervals of about one second. When "2" is displayed on the 7-segment LED, press the push switch.
- (5) On the 7-segment LED, "2" blinks.
- (6) Press the push switch once more. The blinking stops and the node number saved to the CNC is displayed.

- (7) Set the rotary switch to a proper position according to Appendix H.5, "START SEQUENCE SWITCHING". Next, turn off the CNC then turn on the CNC again.

### Confirming the node number in normal operation

When the CNC is performing normal operation, the node number blinks on the 7-segment LED while the push switch is held down with the rotary switch set to "3".

#### NOTE

Upon completion of node number confirmation, be sure to return the rotary switch to the previous position.

## H.5 CHANGING START SEQUENCES

The start procedure can be changed by using the rotary switch on a CNC.

### In normal operation: "0" (Function number 0)

When a CNC is started, the CNC waits for establishment of communication with the personal computer. The personal computer displays the CNC screen used in normal operation.

### When no display unit is connected: "E" (Function number E)

When a CNC is started, the CNC does not wait for establishment of communication with the personal computer. This means that the CNC is started even when no personal computer is connected as a display unit.

When the CNC is connected with the personal computer, the personal computer displays the CNC screen used in normal operation.

### In maintenance operation: "F" (Function number F)

When a CNC is started, the CNC waits for establishment of communication with the personal computer. The personal computer displays the boot screen.

#### NOTE

When the rotary switch is set to "0" or "F", the CNC is not started until communication with the personal computer is established.

**Tip: Hardware locations related to Ethernet Display function**

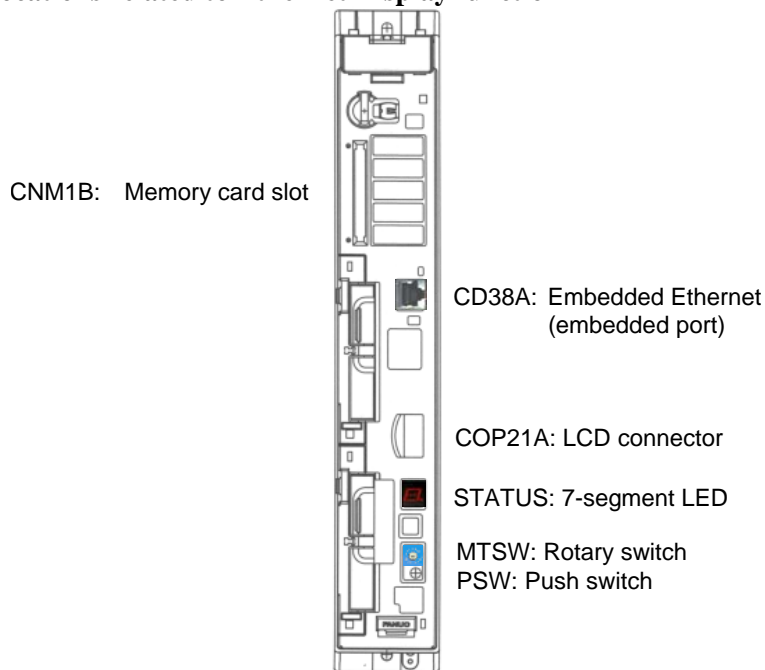

Fig. H.5 (a) Hardware locations related to the Ethernet display function

## H.6 NCBOOT32E.exe

NCBOOT32E.exe is software that monitors communication between the personal computer and CNCs and displays a maintenance screen as needed.

**NOTE**

NCBOOT32E.exe is held on the Disk for CNC Screen Display function.

Set the rotary switch to **"F" (Function number F)** then start the CNC. The boot screen and the IPL screen are displayed in this order.

With NCBOOT32E.exe, application software to be started after the IPL screen is displayed can also be registered. Usually, CNC Screen Display function (CNCSrnE.exe) is registered.

NCBOOT32E.exe resides on the system tray after the start-up.

By right-clicking the icon (circled on the screen below) on the system tray, the pop-up menu shown Fig. H.6 (a) is displayed.

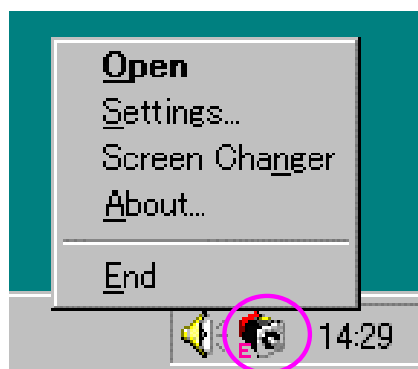

Fig. H.6 (a)

When [Open] is selected, the status screen is displayed.

When [Settings...] is selected, the option setting screen is displayed.

When [Screen Changer] is selected, the changer screen is displayed.

When [About...] is selected, the version information dialog box is displayed.  
 When [End] is selected, NCBOOT32E.exe ends.

Double-clicking the icon on the system tray displays the status screen.

By left-clicking the icon on the system tray, the pop-up menu shown Fig. H.6 (b) is displayed. Those CNCs that are not currently connected are dimmed.

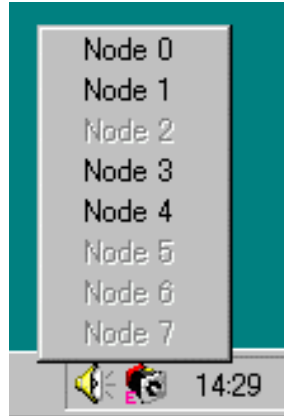

Fig. H.6 (b)

When a node number is selected from the pop-up menu, the current screen (boot screen, IPL screen, CNC alarm screen, or screen of an automatically started application) of the currently connected CNC can be displayed in the forefront.

**NOTE**  
 To operate NCBOOT32E.exe, the use of a mouse or a touch panel is recommended.

## H.6.1 Boot Screen

If the rotary switch on a CNC is set to "F" (Function number F), the boot screen is displayed when communication between NCBOOT32E.exe and the CNC is established.  
 When multiple CNCs are connected, multiple boot screens are displayed.

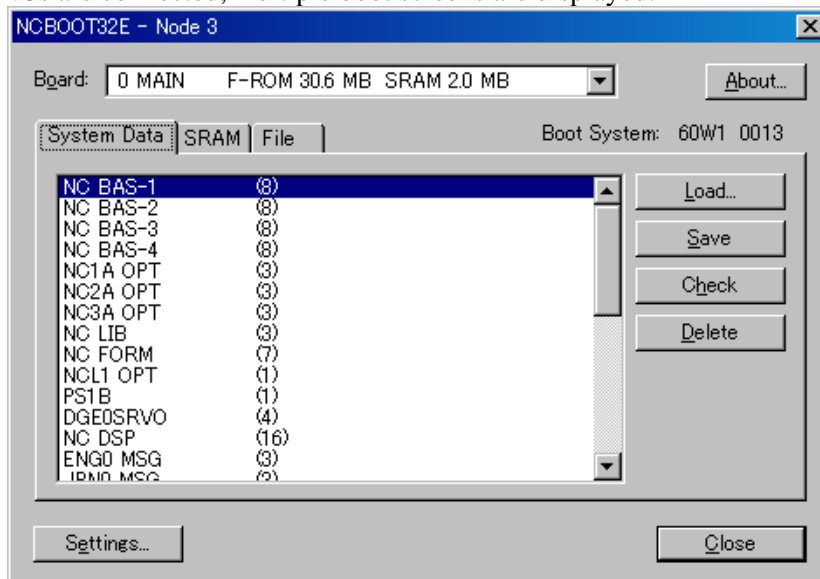

Fig. H.6.1 (a)

The following operations can be performed on the boot screen:

- Selection of a location to which an F-ROM/S-RAM file is to be saved (the memory card of the CNC or a folder on the hard disk of the personal computer)
- Writing files of user data (such as macro programs and ladder programs) to the F-ROM of the CNC
- Saving user data held on the F-ROM to a file
- Checking system data or user data held on the F-ROM
- Deleting user data from the F-ROM
- Backing up the data held on the S-RAM of the CNC to a file
- Restoring the S-RAM data backed up to a file to the CNC
- Restoring the S-RAM data automatically backed up to the F-ROM
- Formatting the memory card of the CNC

## H.6.2 File Storage Location Selection

Clicking the [Settings...] button displays the screen shown Fig. H.6.2 (a). Specify a location for storing an user data file or S-RAM data file.

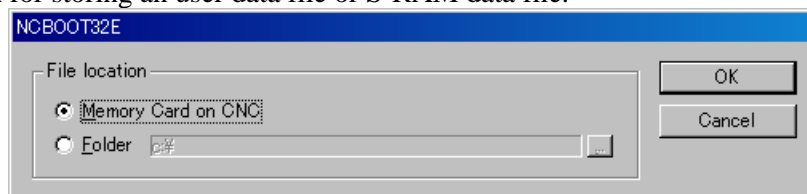

Fig. H.6.2 (a)

Select the memory card of the CNC or a folder on the hard disk of the personal computer. The selection can be changed at any time.

## H.6.3 User Data Operation

Clicking the [System Data] tab displays a screen as shown Fig. H.6.3 (a). The screen is used to operate user data written in the F-ROM of the CNC.

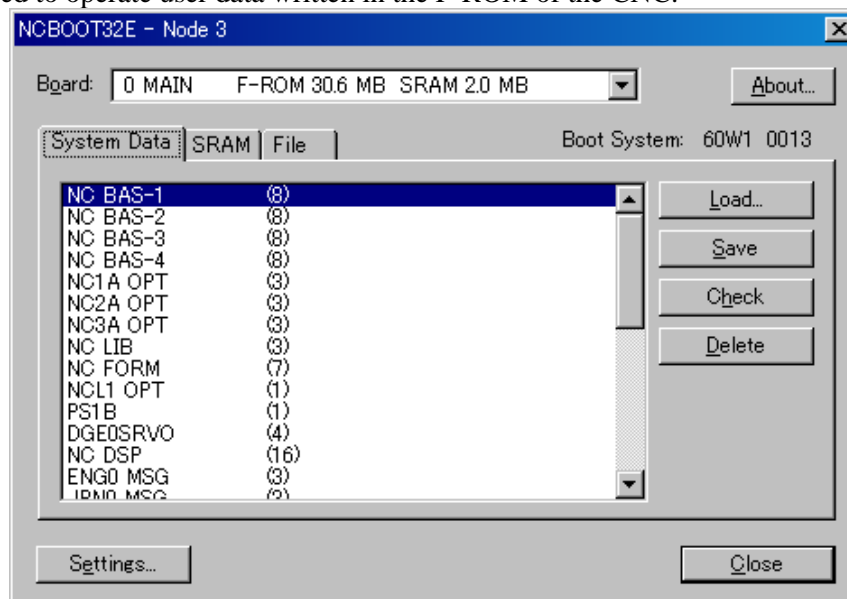

Fig. H.6.3 (a)

Clicking the [Load...] button displays the file selection screen.

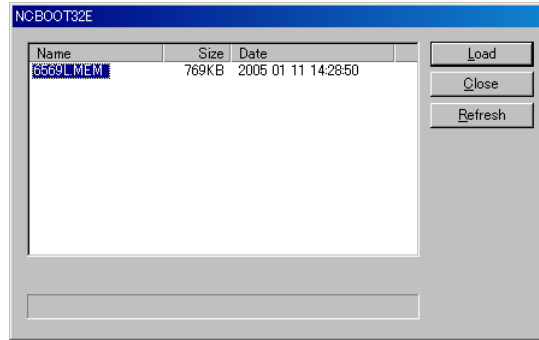

Fig. H.6.3 (b)

Select user data to be stored in the F-ROM of the CNC then click the [Load] button. The selected file or files are written into the F-ROM of the CNC.

Clicking the [Save] button saves user data selected from the F-ROM of the CNC to a file.

Clicking the [Check] button checks selected system data or user data and displays check information.

Clicking the [Delete] button deletes selected user data from the F-ROM of the CNC.

**NOTE**

Only user data holding ladder programs and so forth can be operated as system data with the [Load] button, [Save] button, and [Delete] button.

## H.6.4 S-RAM Operation

Clicking the [SRAM] tab displays a screen as shown Fig. H.6.4 (a).

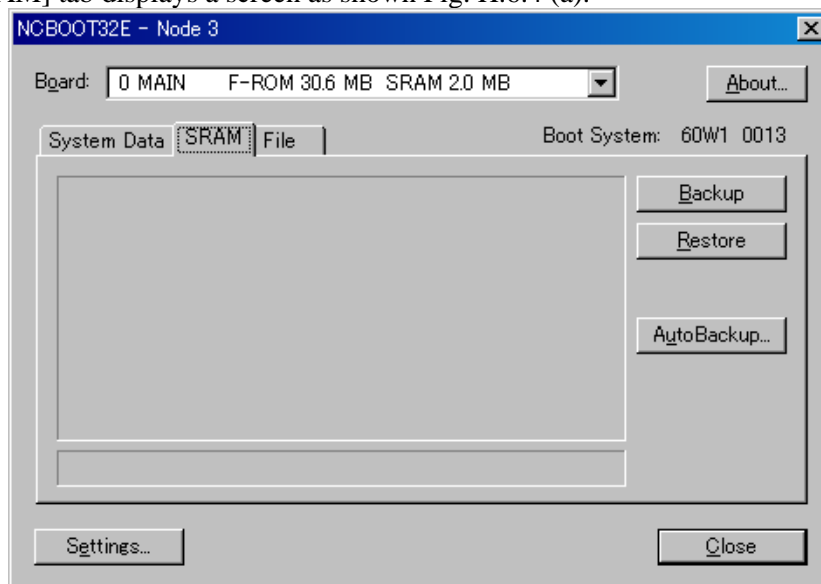

Fig. H.6.4 (a)

This screen is used to operate data stored in the S-RAM of the CNC.

Clicking the [Backup] button backs up S-RAM data to a file.

Clicking the [Restore] button restores S-RAM data backed up to a file to the CNC.

Clicking the [AutoBackup...] button displays the file selection screen.

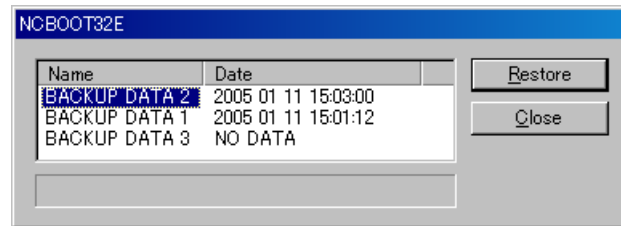

Fig. H.6.4 (b)

The screen displays S-RAM data automatically backed up by the CNC to the F-ROM.

To restore data, select the data then click the [Restore] button. The name of a backup file is automatically determined and cannot be modified.

## H.6.5 File Operation

Clicking the [File] tab displays a screen as shown Fig. H.6.5 (a).

This screen is used to operate files on the memory card of the CNC or on the hard disk of the personal computer.

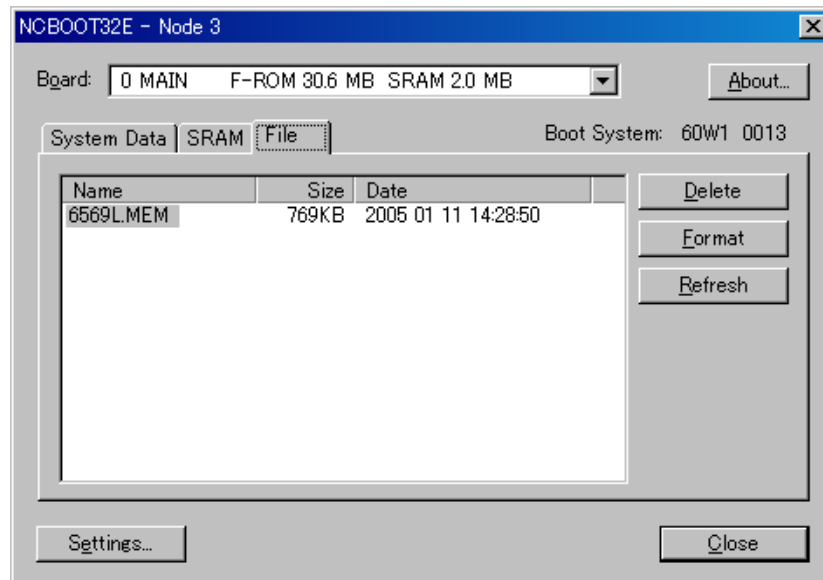

Fig. H.6.5 (a)

Clicking the [Delete] button deletes a selected file.

Clicking the [Format] button formats the memory card of the CNC. This button is enabled only when the memory card is selected with [Settings...].

Clicking the [Refresh] button updates the list of files. Click this button when the memory card is replaced.

### NOTE

When the memory card is formatted, all data on the memory card is erased.



## H.6.6 IPL Screen

By clicking the [Close] button on the boot screen, the boot screen disappears and the IPL screen is displayed.

When multiple CNCs are connected, multiple IPL screens are displayed.

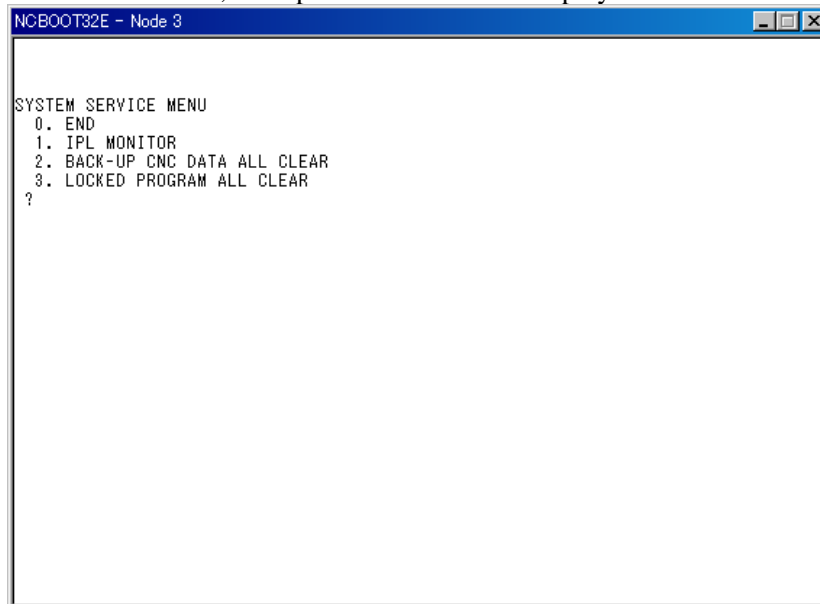

Fig. H.6.6 (a)

On the IPL screen, the following functions can be selected:

- Starting of the IPL monitor
- Clearing of data stored in the S-RAM of the CNC
- Clearing of CNC parameters

Supplement)

If a CNC-dedicated display unit is connected, a function of SYSTEM SERVICE MENU of the IPL screen can be operated according to the corresponding MDI key operation performed at CNC power-on time. If Ethernet Display function is used, however, such MDI key operation is disabled. In this case, select a desired function from SYSTEM SERVICE MENU on the IPL screen.

Table H.6.6 (a)

SYSTEM SERVICE MENU items corresponding to the operations listed in right-hand column	(Tip) MDI key operations on CNC-dedicated display unit at power-on time
0. END	None
1. IPL MONITOR	<←> + <. >
2. BACK-UP CNC DATA ALL CLEAR	<DELETE> + <RESET>
3. LOCKED PROGRAM ALL CLEAR	<M> + <O>

## H.6.7 CNC Alarm Screen

The CNC alarm screen is displayed when a system alarm occurs from a CNC.  
 If a system alarm occurs from multiple CNCs, multiple CNC alarm screens are displayed.

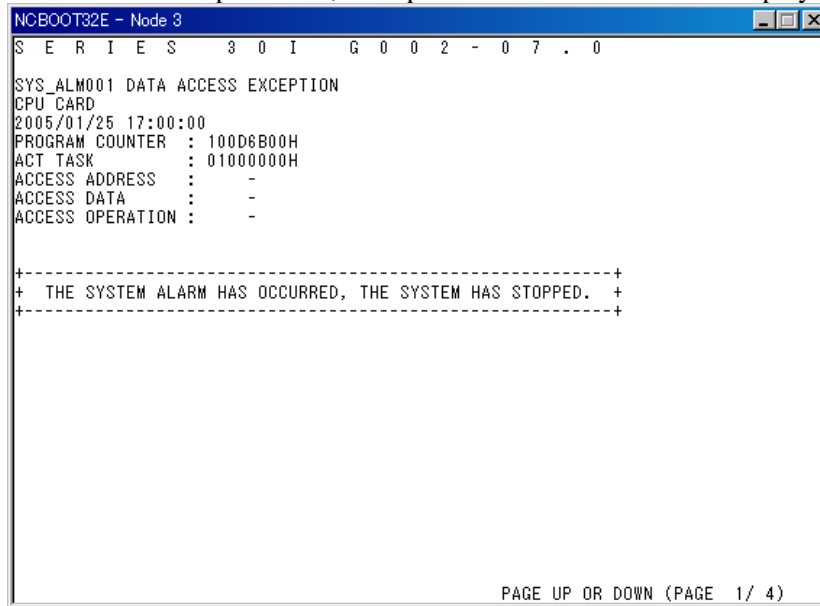

Fig. H.6.7 (a)

(The screen above is just an example. Display information varies according to a system alarm issued from a CNC.)

**⚠ CAUTION**  
 If a system alarm occurs due to a very serious fault related to the memory, main CPU, or Embedded Ethernet, the CNC system alarm screen might not be displayed.

For details of CNC alarm screen operation and display, see Section 11.25, "SYSTEM ALARMS", and Section 11.26, "SYSTEM ALARMS RELATED TO THE PMC AND I/O LINK".

## H.6.8 Status Screen

When any of the following operations is performed, a screen as shown Fig. H.6.8 (a) is displayed:

- Double-click the icon on the system tray
- Right-click the icon on the system tray then click [Open] on the pop-up menu

By checking [Pop up this window on communication error] beforehand, the screen is displayed immediately when a communication error occurs.

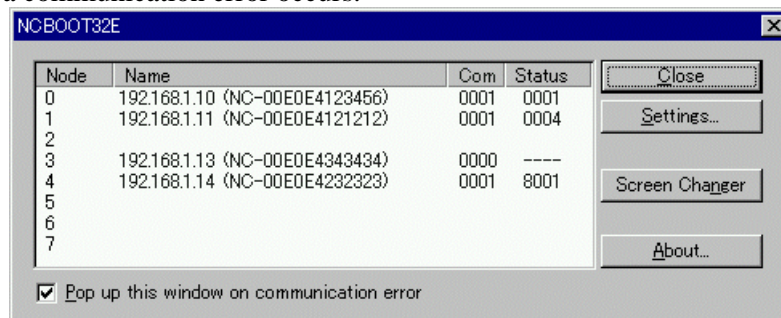

Fig. H.6.8 (a)

On the status screen, the IP address and MAC address, current communication status, and other statuses of each CNC currently connected can be checked.

- Node : CNC node number (0 to 7)  
 When a duplicate IP address or MAC address is specified for a CNC, the node number is followed by "X". In this case, normal communication is disabled.
- Name : Name of a CNC based on the IP address and MAC address  
 Blank : Not connected  
 ---- : Duplicate IP address or MAC address
- Com : Communication status  
 Blank : Disconnected  
 0000 : Status that the communication was established once but it is being disconnected now  
 0001 : Connecting  
 8000 : Communication error in progress  
 ---- : Duplicate IP address or MAC address
- Status : CNC status  
 Blank : Disconnected  
 0001 : Boot processing in progress  
 0002 : Boot processing completed  
 0003 : IPL processing in progress  
 0004 : IPL processing completed  
 0010 : Steady state  
 0011 : The node number is not 0 though CNC does not have the option of Ethernet Display function  
 8??? : System alarm issued  
 ---- : Communication stopped, communication error, duplicate IP address or MAC address

## H.6.9 Option Setting Screen

When any of the operation is performed, a screen as shown Fig. H.6.9 (a) is displayed:

- Right-click the icon on the system tray then click [Settings...] on the pop-up menu
- Click [Settings...] on the status screen

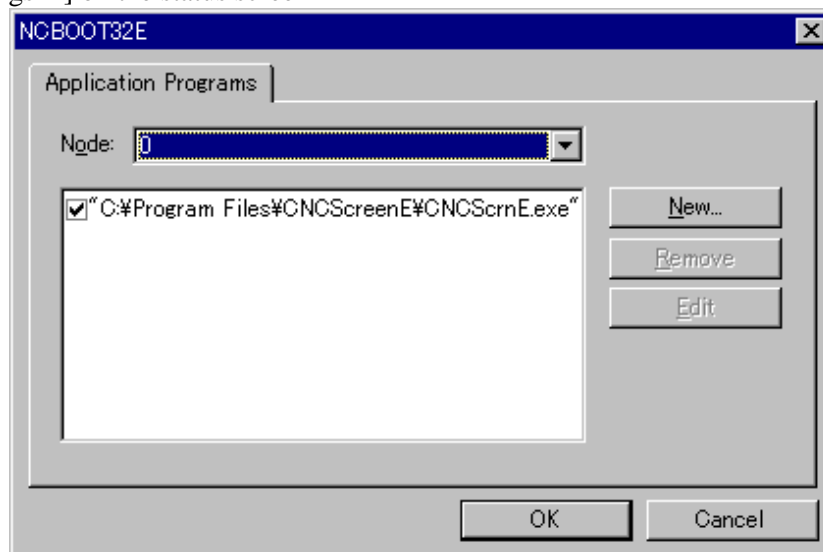

Fig. H.6.9 (a)

On the option setting screen, application software for display to be started after IPL processing can be registered.

In addition, turning on the check box causes the application software of interest to run in association with the changer screen, thus enabling the following operations.

(For details, see H.6.10, “Changer Screen”).

- When a node number is selected on the changer screen, the checked application software is displayed at the forefront and thus becomes operable.
- When the checked application software is exited, a prompt is displayed to ask whether to restart it. If you want to keep any application software running, you are recommended to turn on the check box for it.

When a node is selected from the [Node] list box, the name of the application software registered for the node is displayed at the center of the screen.

Clicking the [New...] button can register an application name. If the path includes a blank character, enclose the path in double quotation marks.

Clicking the [Remove] button deletes a selected application name.

Clicking the [Edit] button enables a selected application name to be edited. When an argument is specified, the character string "%s" in the command line is replaced with an IP address. To represent "%" itself, code "%%".

Example)

To operate CNC Screen Display function, code an application name as follows:

```
"C:\Program Files\CNCScreenE\CNCScrnE.exe" /H=%s:8193
```

For each node (CNC), multiple applications can be registered on the option setting screen. All registered applications are started simultaneously.

If a register application software cannot be started normally, the dialog box "Node [xxx]:Couldn't execute the Application Program.[yyy]" is displayed. ([xxx] represents a node number, and [yyy] represents a command line character string.)

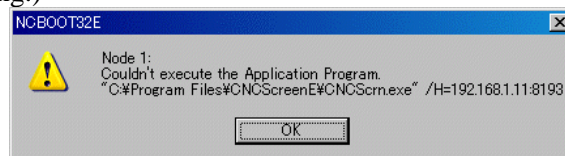

Fig. H.6.9 (b)

## H.6.10 Changer Screen

When any of the following operations is performed, a screen as shown Fig. H.6.10 (a) is displayed:

- Right-click the icon on the system tray then click [Screen Changer] on the pop-up menu
- Click [Screen Changer] on the status screen
- Press the hotkey (Ctrl-Alt-N)



Fig. H.6.10 (a)

The changer screen is displayed in the forefront with other screens hidden behind.

The changer screen is always laid on the other screens.

In addition, any application software registered with its check box turned on the option setting screen, the BOOT screen, IPL screen, and the CNC alarm screen (hereafter generically referred to as the changer-target application) operate in association with the changer screen.

A depressed node number on the changer screen means that the corresponding changer-target application is displayed at the forefront.

If the changer target application that should have been automatically started is terminated, the dialog box "Node [xxx]:The registered Application Program has terminated. Restart? [yyy]" is displayed. Clicking the [Yes] button starts the application again. ([xxx] represents a node number, and [yyy] represents a command line character string.)

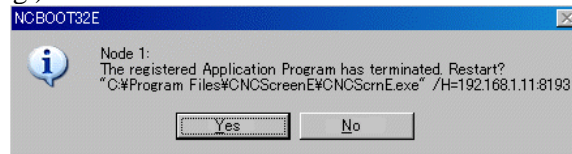

Fig. H.6.10 (b)

**NOTE**

When you click the [No] button, the changer target application is not started again. Even if the changer target application is manually started later, interaction with the changer screen is disabled.

Clicking a non-depressed node number causes the changer-target application corresponding to the non-depressed node number to be displayed at the forefront.

Alternatively, pressing the Shift+Fx keys causes the changer-target application corresponding to the node number related to Shift+Fx to be displayed at the forefront.

Shift+F1: Node0, Shift+F2: Node1, Shift+F3: Node2, Shift+F4: Node3、

Shift+F5: Node4, Shift+F6: Node5, Shift+F7: Node6, Shift+F8: Node7

If no changer-target application is found, the "Node [xxx]:No Application Program exists for this node." dialog box appears (where [xxx] is a node number).

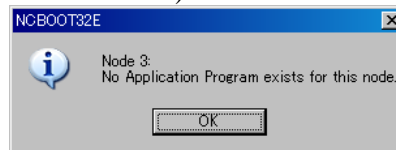

Fig. H.6.10 (c)

## H.7 STARTING OF THE CNC SCREEN DISPLAY FUNCTION

**NOTE**

To use CNC Screen Display function (A02B-0207-J858), its option is required.

To operate CNCScrnE.exe (CNC Screen Display function) after CNC initialization, the application name of CNC Screen Display function needs to be registered on the option setting screen of NCBOOT32E.exe. At this time, add an argument (/H=%s:8193) for specification of the IP address and port number of the CNC to the application name.

If CNC Screen Display function is operated when no argument is added to the application name, the screen shown Fig. H.7 (a) is displayed, and the IP address and port number must be set.

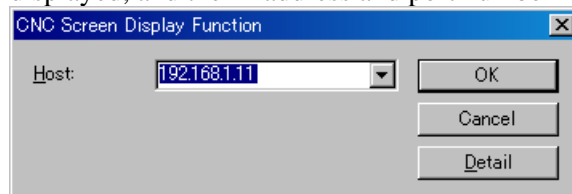

Fig. H.7 (a)

When a connection is made with a CNC, a CNC screen as shown Fig. H.7 (b) is displayed. The title bar indicates the IP address and port number of the CNC.

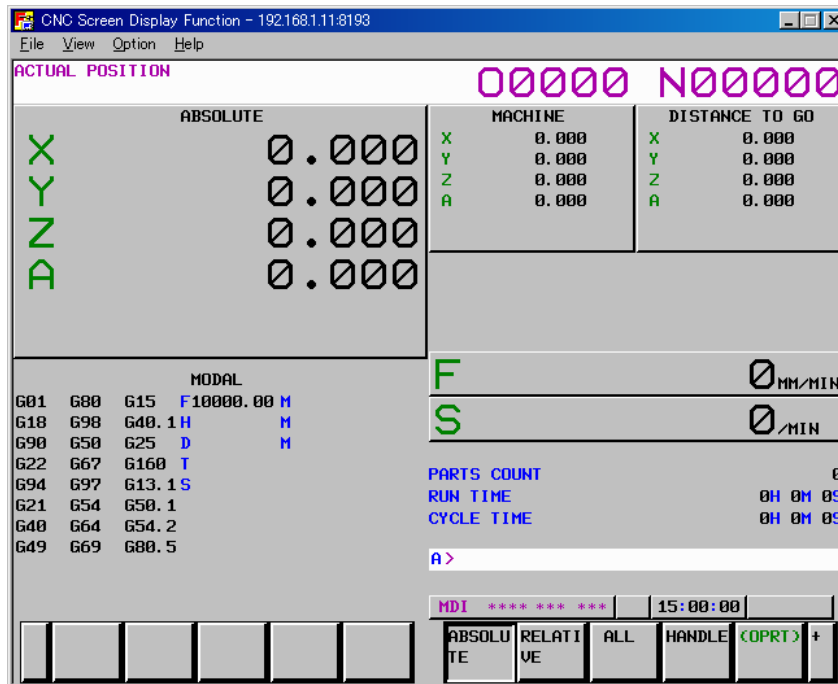

Fig. H.7 (b)

**Related NC parameters**

	#7	#6	#5	#4	#3	#2	#1	#0
13114								P15

[Data type] Bit

- #0 P15** When the screen is displayed using the CNC screen display function:
  - 0: The 10.4" mode is used.
  - 1: The 15" mode is used.

**NOTE**  
 This parameter is effective when CNC Screen Display function is used with the stand-alone type Series30i/31i/32i.

# IPL MONITOR

Appendix I, "IPL MONITOR", consists of the following sections:

I.1 OVERVIEW .....	805
I.2 STARTING OF THE IPL MONITOR.....	805
I.3 IPL MENU .....	806

## I.1 OVERVIEW

With the IPL monitor, the following operations can be performed:

- 1) Clearing of individual files  
CNC parameters, tool compensation data, and so forth can be cleared.
- 2) Output of system alarm information  
System alarm information stored as history information can be output to the memory card.

### WARNING

- 1 From the IPL monitor menu, do not select an item other than the items listed below.  
The other items represent functions for FANUC service.
  0. END IPL
  3. CLEAR FILE
  5. SYSTEM ALARM UTILITY
- 2 When an individual file is cleared, all data stored in the file is cleared and initialized. So, before clearing an individual file, back up the data of the file as needed.
- 3 If a system label error has occurred, perform a clear operation according to Appendix J, "MEMORY CLEAR OPERATION", instead of clearing of an individual file.

## I.2 STARTING OF THE IPL MONITOR

The IPL monitor can be started according to the procedure below.

### Other than Personal Computer functions

- <1> Turn on the power by pressing the MDI keys [.] and [-] simultaneously.
- <2> The IPL monitor screen is displayed.

### Personal Computer functions

- <1> Start NCBOOT32.
- <2> Select "1. IPL MONITOR" on the IPL screen.
- <3> The IPL monitor screen is displayed.

For details, see Appendix F, "MAINTENANCE OF PERSONAL COMPUTER FUNCTIONS (BOOT-UP AND IPL)".

## I.3 IPL MENU

When the IPL monitor is started, the following screen (Fig. I.3 (a)) is displayed.

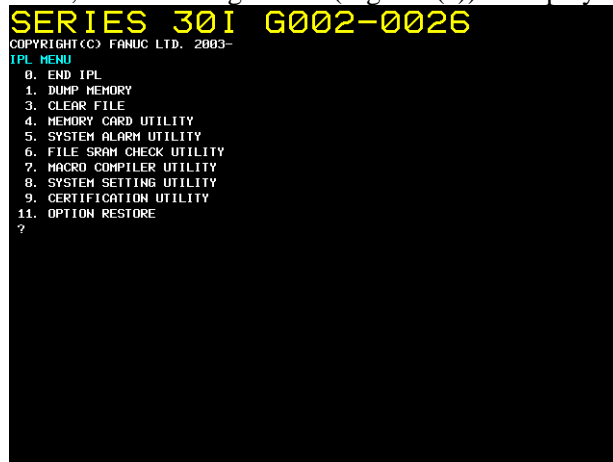

Fig. I.3 (a)

Enter a menu item number by using the corresponding MDI key.

One of the following menu items can be selected:

- 0 : END IPL
- 3 : CLEAR FILE
- 5 : SYSTEM ALARM UTILITY

### END IPL

This menu item ends the IPL monitor and starts the CNC.

### CLEAR FILE

This menu item clears and initializes displayed individual files.

- 1 : All files except option parameter files
- 2 : CNC parameter files
- 3 : Tool compensation data  
Tool compensation memory A, B, and C, tool nose radius compensation data (including virtual tool tip direction),  
Y-axis offset data, second geometric offset, and so forth
- 4 : Program storage files  
A default folder definition file is included.
- 5 : PMC parameter files
- 7 : Custom macro files  
Macro variables, macro variable names
- 8 : Macro executor files  
P code variables
- 9 : Touch panel data files

#### NOTE

The displayed individual file items vary, depending on the system configuration.



```
SERIES 30I G002-0026
COPYRIGHT (C) FANUC LTD. 2003-
CHECK SYSTEM LABEL : END

FILE CLEAR MENU
0. END
1. ALL FILE
2. PARAMETER FILE
3. OFFSET FILE
4. PROGRAM/DIRECTORY FILE
5. PMC PARAMETER FILE
CLEAR FILE NUMBER ?
```

Fig. I.3 (b)

A file can be cleared according to the following procedure:

- <1> Enter the number of a file to be cleared.
- <2> The IPL monitor displays "CLEAR FILE OK ? (NO=0,YES=1)". Enter "1" to clear the file. To cancel the clearing of the file, enter "0".
- <3> When "1" is entered, the specified file is cleared then the menu above is displayed again.
- <4> To clear an additional file, repeat steps <1> through <3>. To quit, enter "0".

### SYSTEM ALARM UTILITY

System alarm information can be output to the memory card.

For details, see Section 11.25, "SYSTEM ALARMS" in Chapter 11, "TROUBLESHOOTING PROCEDURE".

# J MEMORY CLEAR

Appendix J, "MEMORY CLEAR", consists of the following sections:

G.1 OVERVIEW .....808  
 G.2 OPERATION METHOD .....808  
 G.3 DATA TYPES TO BE CLEARED.....809



## J.1 OVERVIEW

If an unexpected error occurs, such as the "SYSTEM LABEL CHECK ERROR" at system startup or the "SYSTEM ALARM", which may be generated suddenly, this function can start up the CNC system in its initial state to return the system to the state in which restoration work can be performed, by clearing all data stored in CNC memory.

## J.2 OPERATION METHOD

1. Starting method

<1> For FS30i-B

When turning the power ON to the CNC, turn the power ON while pressing the MID keys  and  at the same time and holding them down. Keep holding them down until the memory all clear approval screen is displayed.

<2> For Personal Computer functions with Windows® CE or Personal Computer functions with Windows® XP

Use the NC BOOT32 function to display the IPL menu.

From the IPL menu, select "2. BACK-UP CNC DATA ALL CLEAR".

For details, see the chapter on "MAINTENANCE OPERATIONS (BOOT AND IPL) FOR PERSONAL COMPUTER FUNCTIONS".

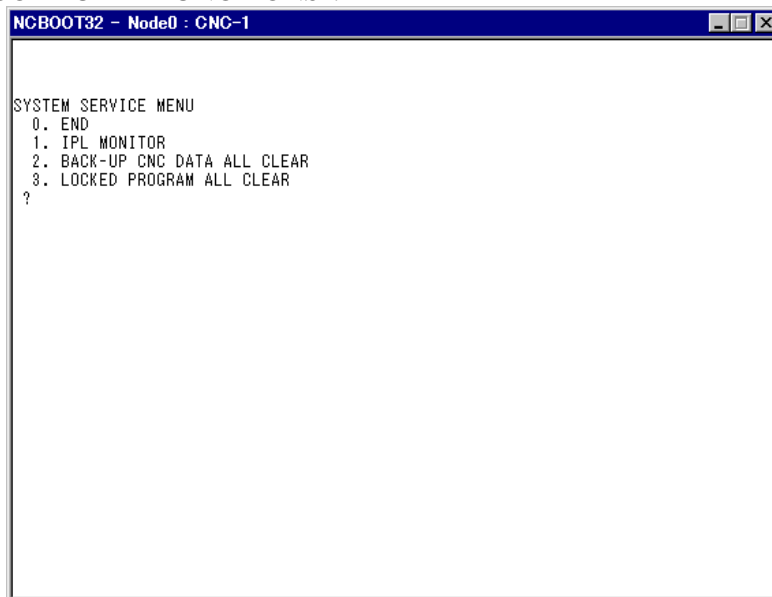

Fig. J.2 (a)

2. Memory all clear approval screen

Performing the operation in 1. causes the following screen to be displayed, asking you whether to execute all clear.



Fig. J.2 (b) Memory All Clear Approval Screen

From the screen shown above, select between the following operation and execute it:

- If you do not want to execute memory all clear, press the numeric key "0". All clear will be canceled.
- To execute memory all clear, press the numeric key "1". All clear will be executed.

#### **WARNING**

- 1 When this operation is performed, the CNC system enters a state (initial state) in which it can start up by itself. To restore various function operations, therefore, you must reconfigure cleared data.
- 2 This operation can be performed only by personnel who have been trained in maintenance and safety.

## J.3 DATA TYPES TO BE CLEARED

The various data types to be cleared by this operation are as follows:

Table J.3 (a)

Data type	Data area
System label	SRAM
Option parameters	SRAM
Data related to C Language Executor (such as SRAM disk data)	SRAM
Data related to macro executor (such as P code variables, extended P code variables, user file data)	SRAM
NC parameters	SRAM
Pitch error compensation data	SRAM
Custom macro variables, variable name	SRAM
Data related to PMC (such as parameters, KEEP relay value)	SRAM
Data related to part program (such as program main body, folder data)	SRAM/ FROM
Tool offset data	SRAM

Data type	Data area
Default folder data	SRAM
Workpiece coordinate system addition data	SRAM
Tool life management data	SRAM
Rotary table dynamic fixture offset data	SRAM
System alarm history data	SRAM
Software operator's panel data	SRAM
Three-dimensional error compensation data	SRAM
Periodic maintenance data	SRAM
Extended keep memory data	SRAM
Interpolation type straightness compensation data	SRAM
M code group data	SRAM
Data related to Fast Data Server / Fast Ethernet (such as parameters)	SRAM
Operation history data	SRAM
Bi-directional pitch error compensation data	SRAM
Extended bi-directional pitch error compensation data	SRAM
Touch panel data	SRAM
Profibus master/slave function data	SRAM
Data related to customer's board (such as parameters)	SRAM
DeviceNet master function data	SRAM
FL-net function data	SRAM
Rigid tapping retraction data	SRAM
Y-axis offset data	SRAM
Tool nose radius compensation value data	SRAM
Cutter compensation value data	SRAM
Second tool geometry offset data	SRAM
Data of interference check for each path	SRAM
Workpiece shift value data	SRAM
Embedded Ethernet data	SRAM
Data of protection of Data at Eight Levels	SRAM
Various data of tool management function	SRAM
Real time custom macro data	SRAM
FSSB data	SRAM
MANUAL GUIDE <i>i</i> data	SRAM
Dual check safety data	SRAM
Data related to C language board function	SRAM

**CAUTION**

The types of data stored in SRAM/FROM differ depending on the system configuration.

# K USB FUNCTION MAINTENANCE

Appendix K "USB FUNCTION MAINTENANCE", consists of the following sections:

K.1 USB FUNCTION MAINTENANCE SCREEN .....811  
 K.2 USB FUNCTION LOG SCREEN .....813

## K.1 USB FUNCTION MAINTENANCE SCREEN

The USB function has maintenance screens.

On the maintenance screens, the USB memory status can be displayed and a USB memory can be formatted.

### Displaying the maintenance screen

#### Procedure

- 1 Press the function key .
- 2 Press soft key [USB]. The USB screen appears. (If soft key [USB] is not displayed, press the continuous menu key.)

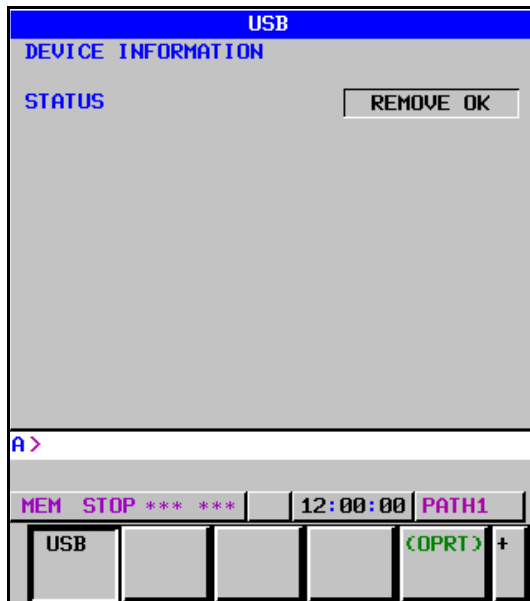

Fig. K.1 (a) USB maintenance screen

### Display items

#### Status

For [STATUS], the USB memory status is displayed as listed below.

State	Description
-----	No USB memory is inserted.
REMOVE OK	A USB memory is inserted, but no data is input or output. The USB memory can be removed and data can be input and output.
ACCESSING	The USB memory is being accessed and cannot be removed.
FORMATTING	The USB memory is being formatted and cannot be removed.
FORMAT OK	Formatting the USB memory terminated normally. The USB memory can be removed and data can be input and output.
FORMAT NG	Formatting the USB memory terminated abnormally. Replace the USB memory.
ERROR	An unrecoverable error occurred. The USB function cannot be used.

**⚠ CAUTION**

While a USB memory is being formatted or is being accessed, do not turn the power to the CNC off or remove the USB memory, or the USB memory may be damaged.

**NOTE**

If [ERROR] is displayed for [STATUS], check the cause on the USB function log screen, remove the cause, and turn the power to the CNC off, then on again.

**Formatting the USB memory****Procedure**

- 1 Press soft key [(OPRT)]. Soft key [FORMAT] is displayed.



- 2 Press soft keys [FORMAT], then [EXECUTE]. Formatting starts.

**⚠ CAUTION**

While a USB memory is being formatted, do not turn the power to the CNC off or remove the USB memory, or the USB memory may be damaged.

**NOTE**

- 1 Formatting may take time depending on the capacity of the USB memory and manufacturer type. Formatting on the CNC once started cannot be canceled.
- 2 Formatting a USB memory deletes all files in the USB memory.
- 3 Any USB memory that is not physically formatted cannot be formatted on the CNC. Format a USB memory to be used for the first time with FAT or FAT32 without specifying the Quick Format option on the personal computer.

## K.2 USB FUNCTION LOG SCREEN

The USB function log screen displays the log related to the USB functions.

### Displaying the USB function log screen

#### Procedure

- 1 Press the function key .
- 2 Press soft key [USB LOG]. The USB LOG screen is displayed. (If soft key [USB LOG] is not displayed, press the continuous menu key.)

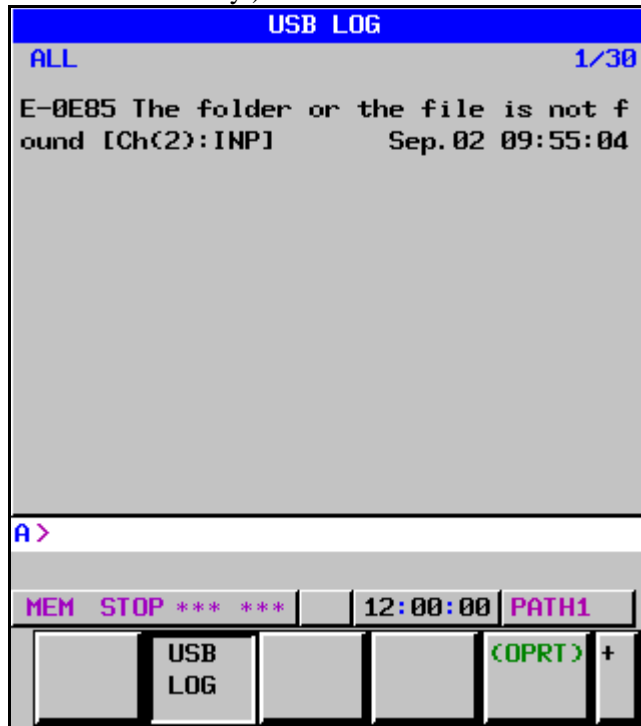

Fig. K.2 (a) Log screen

The latest error log message is displayed at the top of the screen. At the end of the error log message, the date and time when the error occurred are displayed. They are displayed in the following format: “MMM.DD hh:mm:ss” (month (MMM), day (DD), hours (hh), minutes (mm), and seconds (ss)).

In the above example Fig. K.2(a), the date and time are 09:55:04 on September 2.

To clear the log, press soft keys [(OPRT)], then [CLEAR]. (Fig. K.2 (b))



Fig. K.2 (b)

**Errors and log messages**

**NOTE**  
 For a log message, detail log message "[Ch(n):XXX]" may be output simultaneously. If you still have trouble, contact FANUC with the relevant log message and detail log message.

Error number	Log message	Meaning and corrective action
E-0E02	The number of the opening files is over	Up to 60 files can be opened simultaneously.
E-0E03	The finding file is being executed	More than one file cannot be searched for simultaneously. Before a file search terminates, an attempt may be made to start another file search.
E-0E04	The searched file is not found	The file or folder specified for a search is not found in the folder with the specified full path name.
E-0E05	The drive name is wrong	Only drive A can be specified.
E-0E06	FORFANUC cannot be used	No full path can contain "FORFANUC" as the first 8 characters after the route folder like: "A:\FORFANUC (optional characters)\..."
E-0E07	The number of the folder layers is over	Up to six folder layers can be recognized. Possible causes are: <ul style="list-style-type: none"> <li>✓ To create or delete a folder, or obtain a list of files, a folder in the 7th layer is specified with its full path name. For example, The following full path name cannot be specified: "A:\DIR1\DIR2\DIR3\DIR4\DIR5\DIR6\DIR7"</li> <li>✓ To delete a file, rename a folder/ file, open a file, search for a file, or input/output a file, a file in the 7th layer is specified with its full path name. For example, The following full path specification is not allowed: "A:\DIR1\DIR2\DIR3\DIR4\DIR5\DIR6\DIR7\ABC"</li> </ul>
E-0E08 E-0E09 E-0E0A	USB device is being accessed	Formatting cannot be executed. Possible causes are: <ul style="list-style-type: none"> <li>✓ A file in the USB memory is open. [E-0E08]</li> <li>✓ A file search is in progress. [E-0E09]</li> <li>✓ The USB device is being accessed for a purpose other than above. [E-0E0A]</li> </ul>
E-0E0E E-0E0F E-0E13 E-0E14	USB device was removed when accessing	Possible causes are: <ul style="list-style-type: none"> <li>✓ The USB device was removed while a file was open. Then, it was inserted again and file operation (such as write or close) was performed. In this case, the reliability of the file cannot be guaranteed. [E-0E0E, E-0E13]</li> <li>✓ The USB device was removed while a file search was in progress. Then, it was inserted again, the file search was continued or terminated. [E-0E0F, E-0E14]</li> </ul>



Error number	Log message	Meaning and corrective action
E-0E12	(No message)	Sorting failed during file list acquisition. While a list of files was being acquired, a file or folder was possibly added or deleted using another application (such as the C Language Executor). Display the file list screen again.
E-0E40	USB device is not inserted	The USB device cannot be recognized. Possible causes are: <ul style="list-style-type: none"> <li>✓ No USB device is inserted or an attempt was made to access the USB device before recognized.</li> <li>✓ The USB device was removed while it was being accessed.</li> </ul>
E-0E41	USB device is being formatted	An attempt was made to operate the USB device being formatted. Operate the USB device after formatted.
E-0E80	The specified folder or file is wrong	Possible causes are: <ul style="list-style-type: none"> <li>✓ The specified full path name begins with a "(blank)".</li> <li>✓ The specified full path contains a nonexistent folder.</li> <li>✓ The specified full path name contains a non-ASCII code character.</li> <li>✓ The full path name specified for file open or input/output indicates an existing folder.</li> <li>✓ The full path name specified for deleting a file indicates an existing folder.</li> </ul>
E-0E81	The file exists in the specified folder	The specified folder to be deleted contains a file.
E-0E82	The root folder cannot be deleted	The root folder cannot be deleted.
E-0E83		
E-0E84	The folder or the file already exists	Possible causes are: <ul style="list-style-type: none"> <li>✓ To rename a folder/file, the name of an existing folder/file was specified.</li> <li>✓ To open a file for writing data, the name of an existing file was specified and the file is read-only.</li> </ul>
E-0E85	The folder or the file is not found	Possible causes are: <ul style="list-style-type: none"> <li>✓ To delete a file or rename a folder/file, a folder/file with the specified full path name is not found.</li> <li>✓ To open a file for reading data or input a file, a file with the specified full path name is not found.</li> </ul>
E-0E86	USB device has no space	Processing cannot be continued because the capacity of the USB device is insufficient.
E-0E87	USB device is broken	The USB device cannot be recognized normally. Format the USB device with FAT or FAT32 without specifying the Quick Format option on the personal computer again before using it. If this error still occurs, replace the USB device.

Error number	Log message	Meaning and corrective action
E-0E88	Access is denied	Possible causes are: <ul style="list-style-type: none"> <li>✓ The specified folder or file to be deleted is read-only.</li> <li>✓ The specified file to be deleted is open.</li> <li>✓ The specified file to be opened is already open. (An attempt was made to open an open file.)</li> <li>✓ A file opened for writing data was read.</li> <li>✓ A file opened for reading data was written.</li> </ul>
E-0E8D	Access exceeded the file size	An attempt was made to access an invalid position for file pointer setting.
E-0F40	Overcurrent occurred	The USB device may be damaged. If this error occurs, turn the power to the CNC off, then on again. If this error frequently occurs, replace the USB device.
E-0F41	Parity Error occurred	The main board may be damaged. If this error occurs, then the power to the CNC off, then on again. If this error frequently occurs, replace the main board.
E-XXXX	(No message)	Internal error. Contact FANUC with the error number.

# INDEX

## <Number>

- 7-SEGMENT LED INDICATIONS (BLINKING)..... 766
- 7-SEGMENT LED INDICATIONS (TURNED ON) .. 764

## <A>

- AC SPINDLE.....514
- Additional axis board .....228
- Addresses .....350
- ADJUSTING REFERENCE POSITION (DOG METHOD).....502
- ALARM DS0300 (REQUEST FOR REFERENCE POSITION RETURN).....560
- Alarm history .....136
- ALARM LIST.....617
- ALARM LIST (CNC).....617
- ALARM LIST (PMC).....681
- ALARM LIST (SERIAL SPINDLE) .....715
- ALARM OH0700 (OVERHEAT: CONTROL UNIT).....564
- ALARM OH0701 (OVERHEAT: FAN MOTOR) .....565
- ALARM PS0090 (REFERENCE POSITION RETURN IS ABNORMAL) .....559
- ALARM SR0085 TO SR0087 (READER/PUNCHER INTERFACE ALARM) .....555
- ALARM SV0401 (V READY OFF).....561
- ALARM SV0404 (V READY ON).....563
- ALARM SV0417 (DIGITAL SERVO SYSTEM IS ABNORMAL).....564
- ALARM SV0462 (SEND CNC DATA FAILED) .....563
- ALARM SV0463 (SEND SLAVE DATA FAILED).....563
- ALARM SV5134 (FSSB: OPEN READY TIME OUT).....565
- ALARM SV5137 (FSSB: CONFIGURATION ERROR) .....565
- ALARM SV5197 (FSSB: OPEN TIME OUT) .....565
- ALARM SV5136 (FSSB: NUMBER OF AMPS IS SMALL).....566
- Alarms for built-in detectors ( $\alpha_i$  and  $\beta_i$  Pulsecoders) and troubleshooting actions.....603
- Alarms for separate detectors and troubleshooting actions .....604
- Analog Input Separate Detector Interface Unit .....311
- Appearance inspection of the linear motor (magnet plate).....602
- ATTACHING A COMPACT FLASH CARD ONTO, AND DETACHING IT FROM, A PRINTED CIRCUIT BOARD .....262
- Attaching and Detaching Units .....250
- AUTOMATIC DATA BACKUP.....327
- AUTOMATIC OPERATION CANNOT BE DONE...544
- Automatic Setting of Standard Parameters.....524
- Automatic start of trace setting .....380

## <B>

- Backing Up and Restoring Communication Parameters.....464
- Basic Configuration of PMC.....332

- Basic Specifications .....346
- Bode graph .....120
- BOOT Screen.....770,795
- BOOT SYSTEM.....744

## <C>

- Cable Clamp and Shield Processing.....245
- Cautions .....758
- CAUTIONS COMMON TO THE OTHER UNITS ....285
- CAUTIONS FOR REPLACEMENT .....249
- CAUTIONS RELATED TO GROUNDING AND NOISE .....242
- CC-Link Board.....239
- Changer Screen .....802
- CHANGING START SEQUENCES .....769,793
- Checking PMC Alarms ([PMC ALARM] Screen).....356
- Circle graph.....105
- CNC Alarm Screen .....774,800
- CNC STATE DISPLAY .....44
- Collective Monitor Function.....394,395
- COLOR SETTING SCREEN .....65
- Communication Method for External I/O Device .....335
- Confirming the Parameters Required for Data Output.321
- Connection Diagram of a Display Unit for the Stand-Alone Type Control Unit .....167
- Connection of I/O Module for Operator's Panel and I/O Module for Power Magnetics Cabinet [Supporting I/O Link *i*] .....290
- Consumables .....742
- Contents Displayed .....13
- Control Unit Connection Diagram .....163
- CONTROL UNIT HARDWARE .....159
- CORRECTIVE ACTION FOR FAILURES .....532
- Correspondence between operation mode and parameters on spindle tuning screen.....522
- CYCLE START LED SIGNAL HAS TURNED OFF.549

## <D>

- Data Input/Output ([I/O] Screen) .....367
- DATA TYPES TO BE CLEARED.....809
- DEFINITION OF WARNING, CAUTION, AND NOTE .....s-1
- Detailed troubleshooting methods.....604
- DeviceNet Board.....233
- DIAGNOSIS FUNCTION .....13
- DIGITAL SERVO .....479
- DISPLAY AND OPERATION.....1
- Display Method.....9,46,517
- Display of the servo amplifier operation status.....611
- Display Unit (10.4" LCD unit A).....203,268
- Display unit (10.4" LCD unit B and 15" LCD unit) .....206,268
- Display Unit for Automotive .....276
- Display unit for automotive manufacture.....211,269
- Display Unit for Stand-alone Type Control Unit ..203,268

- Display Unit for Stand-alone Type Control Unit (10.4" LCD Unit) .....258
  - Display Unit for Stand-alone Type Control Unit (Personal Computer Function with Windows® CE) .277
  - Display Unit for Stand-Alone Type Control Unit (with Personal Computer Function with Windows®CE)....219
  - Display Unit Number Confirmation.....791
  - Display Unit Number Setting.....790
  - DISPLAY UNIT NUMBER SETTING AND CONFIRMATION .....790
  - Displaying a Program List ([LIST] Screen) .....385
  - Displaying and operating the file list .....469
  - Displaying Diagnosis Screen ..... 13
  - Displaying i/o devices connection status ([I/O DEVICE] screen) .....370
  - Displaying Servo Tuning Screen.....501
  - Displaying the Maintenance Information Screen ..... 131
  - Displaying the Power ON Sequence .....745
  - DOGLESS REFERENCE POSITION SETTING.....505
- <E>**
- Editing Ladder Programs .....389
  - EMBEDDED ETHERNET FUNCTION .....435
  - EMBEDDED ETHERNET OPERATIONS.....466
  - EMBEDDED ETHERNET PORT AND PCMCIA ETHERNET CARD .....435
  - Environmental Conditions outside the Cabinet.....241
  - ENVIRONMENTAL REQUIREMENTS OUTSIDE THE CABINET .....241
  - ERROR CODES (SERIAL SPINDLE).....727
  - ERROR MESSAGES AND REQUIRED ACTIONS ..759
  - ETHERNET DISPLAY FUNCTION .....786
  - EXAMPLE OF HARDWARE CONFIGURATION....159
  - EXAMPLE OF NETWORK CONFIGURATION.....788
  - Example of setting the FOCAS2/Ethernet function ....440
  - Example of setting the FTP file transfer function .....443
  - Example of the Hardware Configuration of the LCD-mounted Type Control Unit .....159
  - Example of the Hardware Configuration of the Stand-alone Type Control Unit.....160
  - Execution methods .....457
  - Execution of Trace .....376
  - Execution Order and Execution Time Percentage.....337
  - EXPLANATION OF SCREENS .....770
  - External operator message history .....138
- <F>**
- Fast Ethernet Board.....226
  - File operation .....773,798
  - File Storage Location Selection .....796
  - Fourier graph.....114
  - FSSB SETTING SCREEN.....489
  - FTP File Transfer Function.....466
  - Function Keys .....2
  - FUNCTION KEYS AND SOFT KEYS.....1
  - Functions on the IPL screen .....774
- <G>**
- General Screen Operations.....1
- <H>**
- Half-Size Kana Input on the Maintenance Information Screen.....133
  - HANDLE OPERATION CANNOT BE DONE .....540
  - HARDWARE CONFIGURATION .....763
  - Hardware Configuration Screen.....10
  - HARDWARE OF LCD-MOUNTED TYPE CONTROL UNIT.....171
  - HARDWARE OF OPTIONAL BOARDS .....226
  - HARDWARE OF STAND-ALONE TYPE CONTROL UNIT .....198
  - HARDWARE OVERVIEW .....161
  - HSSB interface board.....229
- <I>**
- $\alpha$ i SERVO INFORMATION SCREEN .....509
  - $\alpha$ i SERVO WARNING INTERFACE .....506
  - I/O Communication Error Messages .....710
  - I/O Link Connection Unit [Supporting I/O Link *i*] .....298
  - I/O Link-AS-i Converter .....302
  - I/O Module for Connector Panel [Supporting I/O Link *i*] .....286
  - I/O Module for Operator's Panel (Supporting Matrix Input) [Supporting I/O Link *i*].....289
  - I/O Module Type-2 for Connector Panel [Supporting I/O Link *i*] .....291
  - I/O Signals of PMC.....332
  - IN A CONNECTOR PANEL I/O UNIT, DATA IS INPUT TO AN UNEXPECTED ADDRESS .....553
  - IN A CONNECTOR PANEL I/O UNIT, NO DATA IS OUTPUT TO AN EXPANSION UNIT .....554
  - INITIAL SETTING SERVO PARAMETERS .....479
  - INPUT AND OUTPUT OF DATA.....319
  - INPUT FROM AND OUTPUT TO I/O DEVICES CANNOT BE PERFORMED, INPUT/OUTPUT CANNOT BE PERFORMED PROPERLY .....551
  - Inputting and Outputting Parameters .....73
  - Inputting CNC Parameters .....324
  - Inputting Custom Macro Variable Values.....326
  - Inputting Part Programs .....326
  - Inputting Pitch Error Compensation Amount.....325
  - Inputting Tool Compensation Amount.....326
  - INPUTTING/ OUTPUTTING DATA .....320
  - INSERTING AND EXTRACTING OPTIONAL BOARDS.....263
  - Installation Conditions of the Control Unit.....241
  - INTERFACE BETWEEN CNC AND PMC.....332,339
  - Investigating the Conditions under which Failure Occurred .....533
  - IPL MENU .....806
  - IPL MONITOR .....805
  - IPL Screen.....773,799
  - Items Common to Units Supporting I/O Link *i* .....285

**<J>**

JOG OPERATION CANNOT BE DONE .....537

**<L>**

LADDER DIAGRAM MONITOR AND EDITOR  
 SCREENS ([PMC LADDER]).....384  
 Lathe system .....516  
 LCD-mounted Type Control Unit ..... 253,266,274  
 LCD-mounted Type Control Unit (10.4" LCD Unit B  
 and 15" LCD Unit) ..... 180  
 LCD-mounted Type Control Unit (8.4" LCD Unit and  
 10.4" LCD Unit A) ..... 171  
 LCD-mounted Type Control Unit (8.4" LCD Unit and  
 10.4" LCD Unit).....257  
 LCD-mounted Type Control Unit (Personal Computer  
 Function with Windows® CE).....267  
 LCD-mounted Type Control Unit (with Personal  
 Computer Function with Windows®@CE) Hardware. 188  
 LCD-mounted Type Control Unit Overview..... 161  
 LED DISPLAY ..... 764  
 LEDS ON UNITS SUPPORTING I/O LINK *i* .....584  
 Lightning Surge Absorber .....247  
 LIST OF ADDRESSES .....398  
 LIST OF MANUALS RELATED TO MOTORS AND  
 AMPLIFIERS .....594  
 LISTS OF UNITS, PRINTED CIRCUIT BOARDS,  
 AND CONSUMABLES ..... 730  
 LOAD BASIC SYSTEM ..... 758  
 LOG SCREEN OF THE EMBEDDED ETHERNET  
 FUNCTION .....474

**<M>**

Main inspection items .....597  
 MAINTENANCE INFORMATION SCREEN ..... 131  
 Maintenance of βiS motor Pulsecoders .....606  
 Maintenance of a Detector .....603  
 Maintenance of a Servo Amplifier .....611  
 MAINTENANCE OF PERSONAL COMPUTER  
 FUNCTIONS (BOOT-UP AND IPL) .....767  
 MAINTENANCE OF STAND-ALONE TYPE UNIT 782  
 Maintenance of the FANUC-NSK spindle unit.....601  
 MAINTENANCE OF THE OTHER UNITS .....285  
 MAINTENANCE SCREEN FOR EMBEDDED  
 ETHERNET FUNCTION .....471  
 MDI UNIT ..... 740  
 Meanings of LEDs on units supporting I/O Link *i* .....584  
 MEMORY CARD FORMAT Screen.....757  
 MEMORY CARD SLOT .....761  
 MEMORY CARD TYPES (FUNCTIONS) .....761  
 MEMORY CLEAR .....808  
 Messages That May Be Displayed on the PMC Alarm  
 Screen .....681  
 Method A of gear change for machining center system  
 (bit 2 (SGB) of Parameter No.3705 = 0) .....516  
 Method B of gear change for machining center system  
 (bit 2 (SGB) of Parameter No.3705 = 1) .....516  
 Method of Node Number Confirmation .....792  
 Method of Node Number Setting .....792

Mode selection .....452  
 MONITORING I/O DIAGNOSIS ([I/O DGN]  
 SCREEN) .....380  
 Monitoring Ladder Diagrams ([LADDER] Screen).....386  
 Monitoring PMC Signal Status ([STATUS] Screen) ...355  
 MOTOR/DETECTOR/AMPLIFIER PREVENTIVE  
 MAINTENANCE.....593  
 MOUNTING AND DEMOUNTING CARD PCBS ....259  
 MOUNTING AND DEMOUNTING FROM/SRAM  
 MODULE.....261  
 Multi-Path PMC Interface .....340  
 MULTI-PMC FUNCTION .....336

**<N>**

NCBOOT32E.exe .....794  
 NET EDITOR screen .....391  
 NO MANUAL OPERATION NOR AUTOMATIC  
 OPERATION CAN BE EXECUTED .....534  
 NODE NUMBER SETTING AND CONFIRMATION792  
 Noise Suppressor.....244  
 Notes .....68,76  
 Notes on motor cleaning .....600  
 Notes on the cutting fluid (informational).....600  
 NOTHING IS DISPLAYED ON THE LCD WHEN  
 THE POWER IS TURNED ON .....550

**<O>**

OPERATING MONITOR.....46  
 Operating the Maintenance Information Screen.....132  
 OPERATING THE PMC SCREEN .....352  
 OPERATION .....782  
 Operation after execution of trace .....377  
 Operation Errors.....695  
 Operation history .....142  
 Operation history signal selection .....148  
 OPERATION METHOD .....808  
 OPERATION OF EACH FUNCTION .....783  
 Operation on the FOCAS2/Ethernet setting screen.....438  
 Operation on the FTP file transfer setting screen.....441  
 Operations for Color Setting .....65  
 Operations on the System Alarm Screen.....568  
 Option Setting Screen .....775,801  
 Option setting screen (Personal Computer Functions  
 with WindowsCE) .....777  
 Option setting screen (Personal Computer Functions  
 with WindowsXP) .....776  
 Optional Information File .....250  
 OTHER SCREENS .....774  
 OTHER UNITS.....740  
 Outline of Spindle Control .....515  
 Outputting all history data.....153  
 Outputting CNC Parameters .....322  
 Outputting Custom Macro Variable Values .....323  
 Outputting Data .....59  
 Outputting Part Program .....323  
 Outputting Pitch Error Compensation Amount .....323  
 Outputting System Alarm History .....158  
 Outputting System Configuration Data .....13

- Outputting Tool Compensation Amount .....323  
 OVERVIEW ..... 764  
 Overview ..... 316,448,566,744,761,767,782,786,805,808  
 Overview of the History Function..... 135
- <P>**  
 Packing.....251  
 PANEL *i*.....312  
 Parameter ..... 66,134,158  
 Parameter Setting .....501  
 Parameters.....47,74,129  
 Periodic cleaning of a motor .....599  
 Personal computer function with Windows® CE for  
 LCD-mounted type Control Unit.....736  
 Personal computer function with Windows® CE for  
 Stand-alone type Control Unit.....737  
 PMC DIAGNOSIS AND MAINTENANCE SCREENS  
 ([PMC MAINT]).....355  
 PMC Signal Addresses.....333  
 PMC SPECIFICATIONS.....346  
 PMC System Alarm Messages .....690  
 POWER MATE CNC MANAGER FUNCTION .....68  
 PREFACE ..... p-1  
 Preventive Maintenance of a Built-in Spindle Motor and  
 Spindle Unit.....600  
 Preventive Maintenance of a Linear Motor.....602  
 Preventive Maintenance of a Motor (Common to All  
 Models).....597  
 Preventive Maintenance of a Servo Amplifier .....610  
 PREVENTIVE MAINTENANCE OF MOTORS AND  
 DETECTORS .....595  
 PREVENTIVE MAINTENANCE OF SERVO  
 AMPLIFIERS.....607  
 PRINTED CIRCUIT BOARDS AND UNITS UNIQUE  
 TO PERSONAL COMPUTER FUNCTION WITH  
 Windows® CE.....736  
 PRINTED CIRCUIT BOARDS COMMON TO  
 LCD-MOUNTED AND STAND-ALONE TYPE  
 CONTROL UNITS .....735  
 PROFIBUS-DP Board.....230  
 PROGRAM LIST EDITOR Screen .....393
- <R>**  
 Related NC parameters .....443,447,463  
 Replacement of a fan motor .....613  
 Replacing a Commercial D-size Alkaline Dry Cells....273  
 REPLACING A FAN.....274  
 Replacing a Lithium Battery .....270  
 Replacing Batteries .....316  
 REPLACING BATTERY FOR ABSOLUTE  
 PULSECODERS .....316  
 REPLACING CONTROL UNIT MAINTENANCE  
 PARTS .....249  
 REPLACING FUSES .....265  
 REPLACING LCD UNITS.....257  
 REPLACING THE BACKUP UNIT .....284  
 Replacing the Batteries in a Separate Battery Case.....317  
 Replacing the Battery.....312  
 Replacing the Battery Built into the Servo Amplifier ..317  
 REPLACING THE DISPLAY CONTROL BOARD  
 FOR THE DISPLAY UNIT .....256  
 Replacing the Fan .....314  
 Replacing the fan for the HDD .....315  
 Replacing the fan in the PANEL *i*.....314  
 Replacing the Fuse on the Display Unit for the  
 Stand-Alone Type Control Unit (with PC Functions  
 Supporting Windows® CE).....269  
 REPLACING THE MAIN BOARD .....253  
 REPLACING THE MEMORY BACKUP BATTERY  
 IN THE CONTROL UNIT.....270  
 REPLACING THE PROTECTION COVER.....278  
 REPLACING THE TOUCH PANEL PROTECTION  
 SHEET .....279,315  
 RESTART OF THE EMBEDDED ETHERNET.....470  
 Routine inspection of the FANUC-NSK spindle unit ..601
- <S>**  
 SAFETY PRECAUTIONS ..... s-1  
 SCREEN CONFIGURATION AND OPERATING  
 PROCEDURE .....747  
 Screen Display .....65,69  
 SEPARATE DETECTOR INTERFACE UNIT.....310  
 Separating Cables.....242  
 SERIAL INTERFACE AC SPINDLE .....515  
 SERVO ALARMS .....566  
 SERVO GUIDE MATE.....77  
 SERVO TUNING SCREEN .....501  
 Setting and Displaying Counter Values ([COUNTR]  
 Screen) .....359  
 Setting and Displaying Data Tables ([DATA] Screen) 361  
 Setting and Displaying Keep Relays ([KEEP RELAY]  
 Screen) .....360  
 Setting and Displaying Variable Timers ([TIMER]  
 Screen) .....357  
 Setting I/O Address for I/O Link *i* and I/O Link .....338  
 Setting of the FOCAS2/Ethernet Function.....437,449  
 Setting of the FTP File Transfer Function.....440  
 Setting of the Unsolicited Messaging Function.....448  
 Setting of Trace Parameter ([TRACE SETING] Screen)  
 .....373  
 Setting on the CNC screen .....454  
 Setting on the personal computer .....457  
 SETTING PARAMETERS FOR INPUT/OUTPUT ....319  
 Setting up DHCP.....445  
 Setting up DNS .....444  
 Setting Up the DNS/DHCP Function.....444  
 SETTING UP THE EMBEDDED ETHERNET  
 FUNCTION.....437  
 Signal Trace Function ([TRACE] Screen) .....372  
 Soft Key Structure.....1  
 Soft Keys.....3  
 Software Configuration Screen .....11  
 SPINDLE ALARMS.....566  
 Spindle Information Screen.....527  
 Spindle monitor screen.....520  
 Spindle Setting and Tuning Screen .....517











# **ADDITIONAL INFORMATION**

Addition and correction of FANUC Series 30i/31i/32i-MODEL B  
MAINTENANCE MANUAL

1. Type of applied technical documents

Name	FANUC Series 30i/31i/32i-MODEL B MAINTENANCE MANUAL
Spec.No. /Version	B-64485EN/01

2. Summary of change

Group	Name / Outline	New, Add, Correct, Delete	Applicable Date
Basic Function			
Optional Function			
Unit			
Maintenance parts			
Notice			
Correction	-Specifications of each case in Section B.1 and Subsection B.4.2 are corrected. -Note of LCD unit in Section B.1 is corrected. -Item of GUI card in Subsection B.4.2 is corrected.		
Another	-Subsection 4.2.9 "Operator's Panel Connection Unit [Supporting I/O Link <i>i</i> ]" is added. -Operator's panel connection unit is added to Table 6.5.8 (b) in Subsection 6.5.8, and Section B.6.		

				TITLE Addition and correction of FANUC Series 30i/31i/32i-MODEL B MAINTENANCE MANUAL	
01	10.08.23	Miyashita	New issue	DRAW. NO. B-64485EN/01-01	CUST.
Edit.	DATE	Design	Description	<b>FANUC LTD</b>	SHEET 1 / 9

## 4.2.9 Operator's Panel Connection Unit [Supporting I/O Link *i*]

### - Specifications

Item	Ordering specifications	Specification
Operator's panel connection unit (source DO)	A16B-2204-0260	DI : 96 points DO : 64 points
Operator's panel connection unit (source DO)	A16B-2204-0261	DI : 64 points DO : 32 points
Fuse (spare parts)	A02B-0163-K111	3.2A

### - Connector, LED, and fuse locations

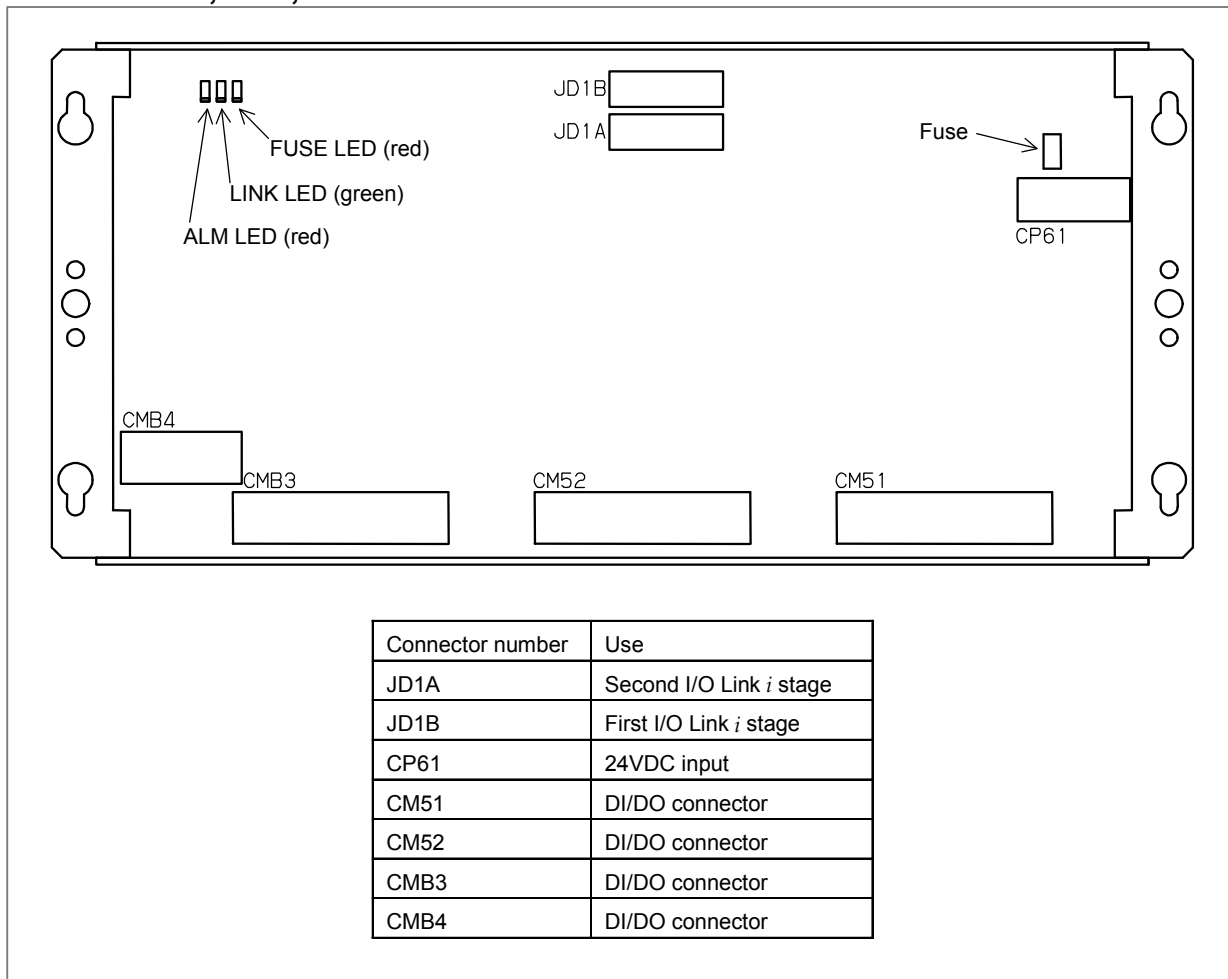

### - LED

This printed circuit board incorporates a green LED, "LINK", and two red LEDs, "ALM" and "FUSE" in above figure.

See Subsection 4.2.1 for descriptions of the correspondence between the on/off state of each LED and the status of the operator's panel connection unit.

				TITLE Addition and correction of FANUC Series 30i/31i/32i-MODEL B MAINTENANCE MANUAL
				DRAW. NO. B-64485EN/01-01
				CUST.
Edit.	DATE	Design	Description	<b>FANUC LTD</b>
				SHEET 2 / 9

**- Correspondence between slot numbers and intra-slot byte addresses**

The table below lists the slot number and intra-slot byte address for this unit.

For A16B-2204-0260

Slot number	Alarm information number	Address of the DO driver which detects an error
1	0	Yn <sub>1</sub>
1	1	Yn <sub>1</sub> +1
1	2	Yn <sub>1</sub> +2
1	3	Yn <sub>1</sub> +3
1	4	Yn <sub>1</sub> +4
1	5	Yn <sub>1</sub> +5
1	6	Yn <sub>1</sub> +6
1	7	Yn <sub>1</sub> +7

For A16B-2204-0261

Slot number	Alarm information number	Address of the DO driver which detects an error
1	0	Yn <sub>1</sub>
1	1	Yn <sub>1</sub> +1
1	2	Yn <sub>1</sub> +2
1	3	Yn <sub>1</sub> +3

Operator's panel connection unit is added to Table 6.5.8(b) in Subsection 6.5.8.

**6.5.8 Displaying i/o devices connection status ([I/O DEVICE] screen)**

**Table 6.5.8 (b) Displayed type of I/O Units (for I/O Link i)**

ID	Displayed I/O Unit
82	OP. PANEL CONNECTION UNIT

				TITLE Addition and correction of FANUC Series 30i/31i/32i-MODEL B MAINTENANCE MANUAL	
				DRAW. NO. B-64485EN/01-01	CUST.
Edit.	DATE	Design	Description	<b>FANUC LTD</b>	
				SHEET	3 / 9

# B.1 UNITS AND PRINTED CIRCUIT BOARDS FOR LCD-MOUNTED TYPE CONTROL UNIT

## NOTE

Read Section B.4 first for information on units with personal computer functions with Windows<sup>®</sup>CE, because some of the printed circuit boards and units used with them are unique.

## Case

Item	Specification	Remark
Case unit: no slot	A02B-0323-C510	*1
Case unit: 1 slot	A02B-0323-C511	*1
Case unit: 2 slots	A02B-0323-C512	*1
Case for no-slot basic unit	A02B-0323-K090	
Case for 1-slot basic unit	A02B-0323-K091	
Case for 2-slot basic unit	A02B-0323-K092	

\*1 The case unit includes the case, fan motor, and battery.

## LCD unit

Item	Specification	ID	Remark
8.4"LCD unit	A02B-0323-D503	–	
8.4"LCD unit (with protection cover)	A02B-0323-D575	–	
10.4"LCD unit A	A02B-0323-D500	–	
10.4"LCD unit A (with protection cover)	A02B-0323-D574	–	
10.4"LCD unit A (with touch panel)	A02B-0323-D570	–	*2
10.4"LCD unit A (with touch panel and protection cover)	A02B-0323-D572	–	*2
10.4"LCD unit B	A02B-0323-D505	0111	
10.4"LCD unit B (with touch panel)	A02B-0323-D507	0111	
10.4"LCD unit B (with protection cover)	A02B-0323-D525	0111	
10.4"LCD unit B (with touch panel and protection cover)	A02B-0323-D527	0111	
15"LCD unit	A02B-0323-D515	0101	
15"LCD unit (with touch panel)	A02B-0323-D517	0101	
15"LCD unit (with protection cover)	A02B-0323-D535	0101	
15"LCD unit (with touch panel and protection cover)	A02B-0323-D537	0101	

\*2 Used in combination with the touch panel control board A20B-8002-0312.

## Printed circuit boards

Item	Specification	ID	Remark
Main board A1	A20B-8200-0720	00338	
Main board A2	A20B-8200-0721	00339	
Main board A4	A20B-8200-0723	0033B	
Main board A5	A20B-8200-0724	0033C	
Main board B5	A20B-8200-0718	0034E	
Main board B7	A20B-8200-0708	0034C	
Main board B5	A20B-8200-0718	0034E	
Main board B7	A20B-8200-0708	0034C	
Main board B6	A20B-8200-0719	0034F	
Main board B8	A20B-8200-0709	0034D	
Main board B6	A20B-8200-0719	0034F	

				TITLE Addition and correction of FANUC Series 30i/31i/32i-MODEL B MAINTENANCE MANUAL
				DRAW. NO. B-64485EN/01-01
				CUST.
Edit.	DATE	Design	Description	<b>FANUC LTD</b>
				SHEET 4 / 9

Item	Specification	ID	Remark
Main board B8	A20B-8200-0709	0034D	
Main board B1	A20B-8200-0712	00352	
Main board B3	A20B-8200-0702	00342	
Main board B1	A20B-8200-0712	00352	
Main board B3	A20B-8200-0702	00342	
Main board B2	A20B-8200-0716	00356	
Main board B4	A20B-8200-0706	00346	
Main board B2	A20B-8200-0716	00356	
Main board B4	A20B-8200-0706	00346	
Back panel (no slot, with power supply)	A20B-8200-0650	01	
Back panel (1 slot, with power supply)	A20B-8200-0670	00	
Back panel (2 slots, with power supply)	A20B-8200-0680	10	
Inverter board (for 8.4" LCD unit)	A20B-8200-0663	1011	
Inverter board (for 10.4" LCD unit)	A20B-8200-0662	1010	
Inverter board (for 15" LCD unit)	A14L-0168-0001	-	
Touch panel control board	A20B-8002-0312	-	
Fan adapter board (for 15" LCD unit)	A20B-8200-0669	-	

### Others

Item	Specification	Remark
Compact flash card	A02B-0323-C990#A	
Connection cable between main board and inverter board	A660-4042-T076#L75R00	For 15" LCD unit

## B.4.2 Personal computer function with Windows® CE for Stand-alone type Control Unit

### Display unit

#### - Display unit with 10.4" LCD unit

Item	Name	Specification	Remark
Display unit A13B-0201-B001	Display control board	A20B-8200-0740	
	Power supply unit	A20B-8101-0011	
	Inverter board	A20B-8200-0662	
	10.4"LCD unit	A02B-0323-D540	ID=1111
	Case	A02B-0323-K090	
Display unit (with touch panel) A13B-0201-B003	Display control board	A20B-8200-0740	
	Power supply unit	A20B-8101-0011	
	Inverter board	A20B-8200-0662	
	10.4"LCD unit (with touch panel)	A02B-0323-D542	ID=1111
	Case	A02B-0323-K090	
Display unit (with protection cover) A13B-0201-B004	Display control board	A20B-8200-0740	
	Power supply unit	A20B-8101-0011	
	Inverter board	A20B-8200-0662	
	10.4"LCD unit (with protection cover)	A02B-0323-D550	ID=1111
	Case	A02B-0323-K090	

				TITLE Addition and correction of FANUC Series 30i/31i/32i-MODEL B MAINTENANCE MANUAL
				DRAW. NO. B-64485EN/01-01
				CUST.
Edit.	DATE	Design	Description	<b>FANUC LTD</b> SHEET 5 / 9



Item	Name	Specification	Remark
Display unit (with touch panel and protection cover) A13B-0201-B006	Display control board	A20B-8200-0740	
	Power supply unit	A20B-8101-0011	
	Inverter board	A20B-8200-0662	
	10.4"LCD unit (with touch panel and protection cover)	A02B-0323-D552	ID=1111
	Case	A02B-0323-K090	

- Display unit with 12.1" LCD unit

Item	Name	Specification	Remark
Display unit A13B-0201-B011	Display control board	A20B-8200-0743	
	Power supply unit	A20B-8101-0011	
	Inverter board	A14L-0143-0003	
	Connection cable between display control board and inverter board	A660-4042-T075#L90R00	
	Fan adapter board	A20B-8200-0669	
	12.1"LCD unit	A02B-0323-D543	ID=1110
	Case	A02B-0323-K090	
Display unit (with touch panel) A13B-0201-B013	Display control board	A20B-8200-0743	
	Power supply unit	A20B-8101-0011	
	Inverter board	A14L-0143-0003	
	Connection cable between display control board and inverter board	A660-4042-T075#L90R00	
	Fan adapter board	A20B-8200-0669	
	12.1"LCD unit (with touch panel)	A02B-0323-D545	ID=1110
	Case	A02B-0323-K090	
Display unit (with protection cover) A13B-0201-B014	Display control board	A20B-8200-0743	
	Power supply unit	A20B-8101-0011	
	Inverter board	A14L-0143-0003	
	Connection cable between display control board and inverter board	A660-4042-T075#L90R00	
	Fan adapter board	A20B-8200-0669	
	12.1"LCD unit (with protection cover)	A02B-0323-D553	ID=1110
	Case	A02B-0323-K090	
Display unit (with touch panel and protection cover) A13B-0201-B016	Display control board	A20B-8200-0743	
	Power supply unit	A20B-8101-0011	
	Inverter board	A14L-0143-0003	
	Connection cable between display control board and inverter board	A660-4042-T075#L90R00	
	Fan adapter board	A20B-8200-0669	
	12.1"LCD unit (with touch panel and protection cover)	A02B-0323-D555	ID=1110
	Case	A02B-0323-K090	

				TITLE Addition and correction of FANUC Series 30i/31i/32i-MODEL B MAINTENANCE MANUAL
				DRAW. NO. B-64485EN/01-01
				CUST.
Edit.	DATE	Design	Description	<b>FANUC LTD</b> SHEET 6 / 9

**- Display unit with 15" LCD unit**

Item	Name	Specification	Remark
Display unit A13B-0201-B021	Display control board	A20B-8200-0741	
	Power supply unit	A20B-8101-0011	
	Inverter board	A14L-0168-0001	
	Connection cable between display control board and inverter board	A660-4042-T076#L75R00	
	Fan adapter board	A20B-8200-0669	
	15"LCD unit	A02B-0323-D546	ID=1101
	Case	A02B-0323-K090	
Display unit (with touch panel) A13B-0201-B023	Display control board	A20B-8200-0741	
	Power supply unit	A20B-8101-0011	
	Inverter board	A14L-0168-0001	
	Connection cable between display control board and inverter board	A660-4042-T076#L75R00	
	Fan adapter board	A20B-8200-0669	
	15"LCD unit (with touch panel)	A02B-0323-D548	ID=1101
	Case	A02B-0323-K090	
Display unit (with protection cover) A13B-0201-B024	Display control board	A20B-8200-0741	
	Power supply unit	A20B-8101-0011	
	Inverter board	A14L-0168-0001	
	Connection cable between display control board and inverter board	A660-4042-T076#L75R00	
	Fan adapter board	A20B-8200-0669	
	15"LCD unit (with protection cover)	A02B-0323-D556	ID=1101
	Case	A02B-0323-K090	
Display unit (with touch panel and protection cover) A13B-0201-B026	Display control board	A20B-8200-0741	
	Power supply unit	A20B-8101-0011	
	Inverter board	A14L-0168-0001	
	Connection cable between display control board and inverter board	A660-4042-T076#L75R00	
	Fan adapter board	A20B-8200-0669	
	15"LCD unit (with touch panel and protection cover)	A02B-0323-D558	ID=1101
	Case	A02B-0323-K090	

**GUI card**

Item	Specification	Remark
GUI card (DDR SDRAM 256MB)	A20B-3300-0671	ID=1111

\* See Section B.3 for descriptions of the GUI card (DDR SDRAM 128MB).

**Compact flash cards on printed circuit boards**

Item	Specification	Remark
Compact flash card	A87L-0001-0173#128MBD	Total capacity: 128MB
	A87L-0001-0173#256MBD	Total capacity: 256MB
	A87L-0001-0173#512MBD	Total capacity: 512MB
	A87L-0001-0173#001GBD	Total capacity: 1GB
	A87L-0001-0173#002GBD	Total capacity: 2GB

				TITLE Addition and correction of FANUC Series 30i/31i/32i-MODEL B MAINTENANCE MANUAL
				DRAW. NO. B-64485EN/01-01
				CUST.
Edit.	DATE	Design	Description	<b>FANUC LTD</b> SHEET 7 / 9

## Backup unit

Item	Specification	Remark
Backup unit	A02B-0303-H160	For installation on the rear of the MDI unit
	A02B-0303-C161	For installation inside a cabinet.
	A02B-0303-H164	For installation on the rear of the MDI unit (QWRTY TYPE B)
Cable for backup unit	A02B-0323-K801	

## B.6 OTHER UNITS

Item	Specification	Remark
I/O module for connector panel (basic module)	A03B-0824-C001	DI/DO : 24/16
I/O module for connector panel (extension module A)	A03B-0824-C002	DI/DO : 24/16 With manual pulse generator interface
I/O module for connector panel (extension module B)	A03B-0824-C003	DI/DO : 24/16 Without manual pulse generator interface
I/O module for connector panel (extension module C)	A03B-0824-C004	DO : 16 2A output module
I/O module for connector panel (extension module D)	A03B-0824-C005	Analog input module
Flat cable between modules for I/O module for connector panel	A03B-0815-K100	Cable length: 20mm Applicable to an inter-module distance of 32 mm
I/O module for operator's panel	A03B-0824-K200	
I/O module for operator's panel (with MPG interface)	A03B-0824-K202	DI/DO : 48/32 With manual pulse generator interface
I/O module for power magnetics cabinet (without MPG interface)	A03B-0824-K203	DI/DO : 48/32 Without manual pulse generator interface
I/O module type-2 for connector panel (basic module B1)	A03B-0824-C040	DI/DO : 48/32 With manual pulse generator interface
I/O module type-2 for connector panel (basic module B2)	A03B-0824-C041	DI/DO : 48/32 Without manual pulse generator interface
I/O module type-2 for connector panel (extension module E1)	A03B-0824-C042	DI/DO : 48/32
Flat cable between modules for I/O module type-2 for connector panel	A03B-0815-K102	Cable length: 35mm Inter-module distance: 5mm
Terminal type I/O module Basic module	A03B-0823-C011	DI/DO : 24/16
Terminal type I/O module Extension module A	A03B-0823-C012	DI/DO : 24/16 With manual pulse generator interface
Terminal type I/O module Extension module B	A03B-0823-C013	DI/DO : 24/16 Without manual pulse generator interface
Terminal type I/O module Extension module C	A03B-0823-C014	DO : 16 2A output module
Terminal type I/O module Extension module D	A03B-0823-C015	Analog input module
Terminal type I/O module Extension module E	A03B-0823-C016	Analog output module
Spare terminals set (for basic and extension module A/B)	A03B-0823-K020	Terminal block for cable side (With one piece of each of T1 to T4 included)

				TITLE Addition and correction of FANUC Series 30i/31i/32i-MODEL B MAINTENANCE MANUAL
				DRAW. NO. B-64485EN/01-01
				CUST.
Edit.	DATE	Design	Description	<b>FANUC LTD</b> SHEET 8 / 9

Item	Specification	Remark
Spare terminals set (for extension module C)	A03B-0823-K011	Terminal block for cable side for extension module C (With one piece of each of T1 and T2 included)
Spare terminals set (for extension module D)	A03B-0823-K012	Terminal block for cable side for extension module D (With one piece of each of T1 and T2 included)
Spare terminals set (for extension module E)	A03B-0823-K013	Terminal block for cable side for extension module E (With one piece of each of T1 and T2 included)
Flat cable A between modules for terminal type I/O module	A03B-0823-K100	Cable length: 100mm, 52 pins Used to connect an extension module
I/O Link connection unit	A02B-0333-C250	
Machine operator's panel: Main panel	A02B-0323-C231	
Machine operator's panel: Sub panel A	A02B-0236-C232	
Machine operator's panel: Sub panel D	A02B-0236-C244	
Operator's panel connection unit (source DO)	A16B-2204-0260	DI/DO : 96/64
Operator's panel connection unit (source DO)	A16B-2204-0261	DI/DO : 64/32
FANUC I/O Link-AS-i converter (for AS-i Ver.2.0)	A03B-0817-C001	
FANUC I/O Link-AS-i converter (for AS-i Ver.2.1)	A03B-0817-C002	
I/O Link signal divider (2ch)	A20B-1007-0680	
I/O Link signal divider (3ch)	A20B-1008-0360	
Separate detector interface unit (basic 4 axes)	A02B-0323-C205	
Separate detector interface unit (additional 4 axes)	A02B-0323-C204	
Analog input separate detector interface unit (basic 4 axes)	A06B-6061-C202	
Optical I/O Link adapter	A13B-0154-B001	
Optical I/O Link adapter (high-speed type)	A13B-0154-B004	
Optical junction adapter for I/O Link	A63L-0020-0002	
Low-loss optical junction adapter	A63L-0020-0004	
Battery case installed outside for control (for LCD-mounted type control unit)	A02B-0236-C282	
Cable for battery case installed outside for control (for LCD-mounted type control unit)	A02B-0323-K103	
Battery case installed outside for control (for stand-alone type control unit)	A02B-0236-C281	With cable for battery
Compact flash card (128MB)	A02B-0281-K601	For data backup For Date Server
Compact flash card (256MB)	A02B-0213-K211	For data backup For Date Server
Compact flash card (1GB)	A02B-0213-K212	For data backup For Date Server
Compact flash card (2GB)	A02B-0213-K213	For data backup For Date Server
Compact flash card (4GB)	A02B-0213-K214	For Date Server
Compact flash card adapter A	A02B-0303-K150	
Compact flash card adapter B	A02B-0236-K150	Adapter which converts the compact flash card to the ATA card.
PC-side HSSB interface board (2CH.) Compatible with the PCI bus	A20B-8101-0162	
PC-side HSSB interface board (1CH.) Compatible with the PCI bus	A20B-8101-0163	

				TITLE Addition and correction of FANUC Series 30i/31i/32i-MODEL B MAINTENANCE MANUAL
				DRAW. NO. B-64485EN/01-01
				CUST.
Edit.	DATE	Design	Description	<b>FANUC LTD</b>
				SHEET 9 / 9

Series30i/31i/32i-MODEL B  
The correction of maintenance manual

1. Type of applied technical documents

Name	Series30i/31i/32i-MODEL B MAINTENANCE MANUAL
Spec No./Version	B-64485EN/01

2. Summary of change

Group	Name / Outline	New, Add, Correct, Delete	Applicable Date
Basic Function			
Optional Function			
Unit			
Maintenance parts			
Notice			
Correction	FROM/SRAM module/ The specification is corrected.	Correct	Immediately
Another	Connector for buzzer interface/ The connector number is changed.	Correct	Immediately
	Compact flash card/ The detaching method is changed.		

3. List of modifications

Page	Description	Remark
164, 170	Section 2.3.1, 2.3.2 Correction of connection diagram	Connector for buzzer interface
182	Section 2.4.2 Correction of table in "FROM/SRAM module and compact flash card mounting location"	FROM/SRAM module
189, 190 220, 221	Section 2.4.3, 2.5.3 Correction of "Connector mounting location"	Connector for buzzer interface
262, 263	Correction of section 3.7	Compact flash card

※ The page shows a pertinent page of B-64485EN/01.

				Title Series30i/31i/32i-MODEL B The correction of maintenance manual	
01	11.04.08	Terashima	First issue.	DRAW. NO. B-64485EN/01-02	CUST
EDIT	DATE	DESIG.	DESCRIPTION	<b>FANUC CORPORATION</b> SHEET 1 / 9	

Section 2.3.1 The name of connector for buzzer was corrected.

## 2.3.1 Control Unit Connection Diagram

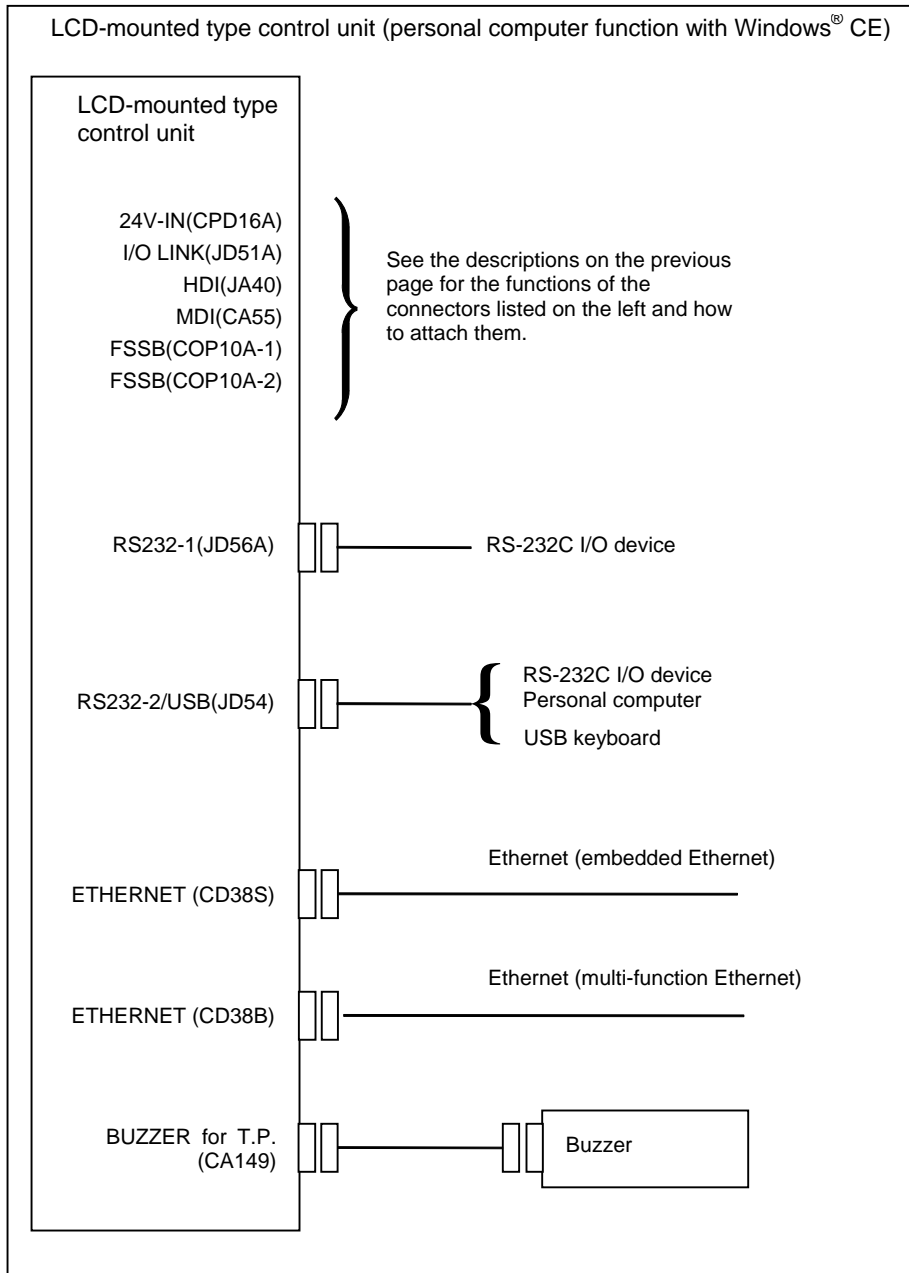

				Title Series30i/31i/32i-MODEL B The correction of maintenance manual
				DRAW. NO. B-64485EN/01-02 CUST
EDIT	DATE	DESIG.	DESCRIPTION	<b>FANUC CORPORATION</b> SHEET 2 / 9

Section 2.3.2 The name of connector for buzzer was corrected.

## 2.3.2 Connection Diagram of a Display Unit for the Stand-Alone Type Control Unit

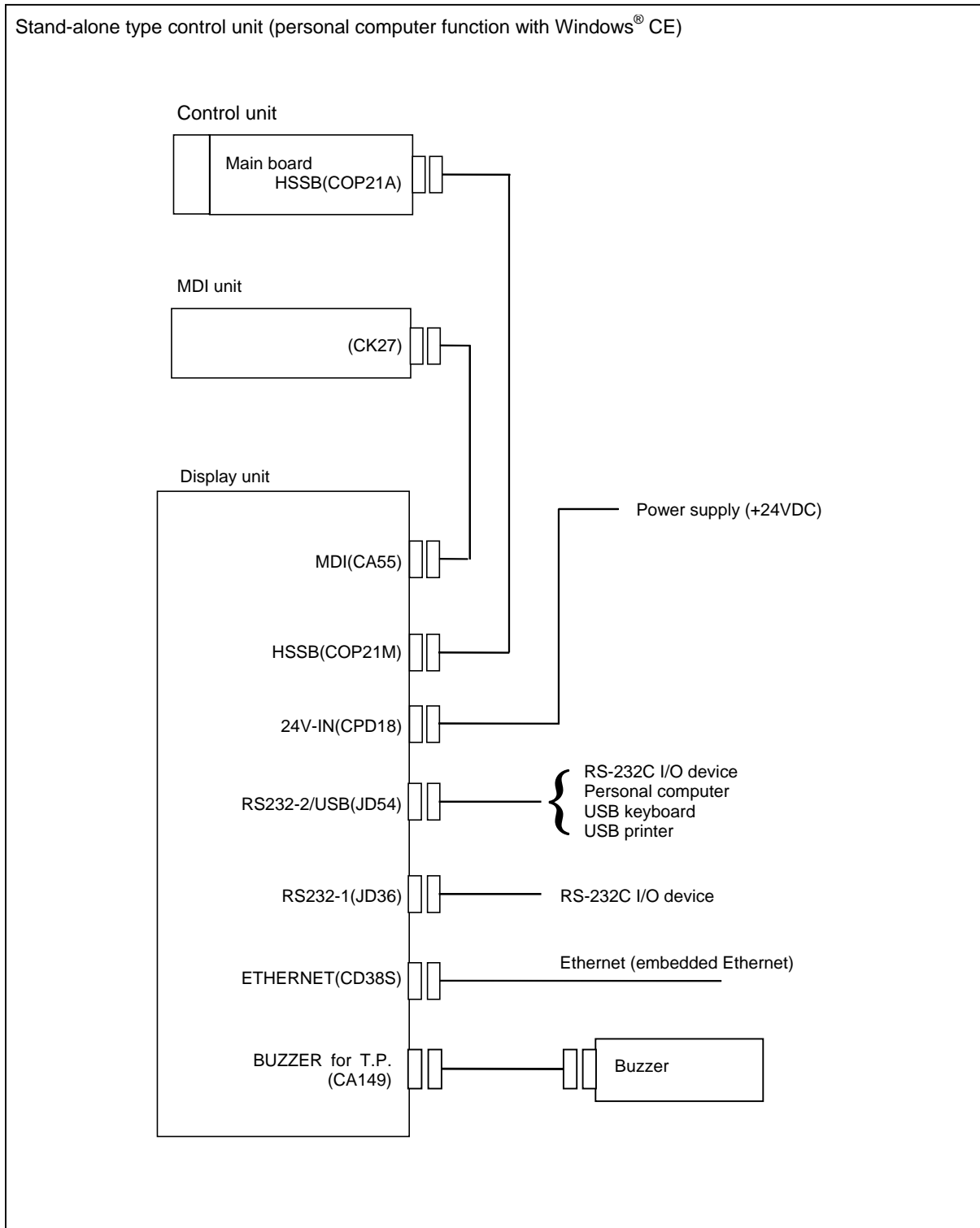

				Title Series30i/31i/32i-MODEL B The correction of maintenance manual
				DRAW. NO. B-64485EN/01-02 CUST
EDIT	DATE	DESIG.	DESCRIPTION	<b>FANUC CORPORATION</b> SHEET 3 / 9

Section 2.4.2 The specification of FROM/SRAM module was corrected.

## 2.4.2 LCD-mounted Type Control Unit (10.4" LCD Unit B and 15" LCD Unit)

- FROM/SRAM module and compact flash card mounting location

No.	Name	Specification	Remark
(1)	FROM/SRAM module	A20B-3900-0250	The FROM stores various control software programs, user software programs, and so forth.
		A20B-3900-0251	
		A20B-3900-0252	The SRAM is a battery-backed memory module.
(2)	Compact flash card	A02B-0323-C990#A	Including software

				Title Series30i/31i/32i-MODEL B The correction of maintenance manual
				DRAW. NO. B-64485EN/01-02 CUST
EDIT	DATE	DESIG.	DESCRIPTION	<b>FANUC CORPORATION</b> SHEET 4 / 9



Section 2.4.3 The name of connector for buzzer was corrected.

## 2.4.3 LCD-mounted Type Control Unit (with Personal Computer Function with Windows®CE) Hardware

### • Connector mounting location

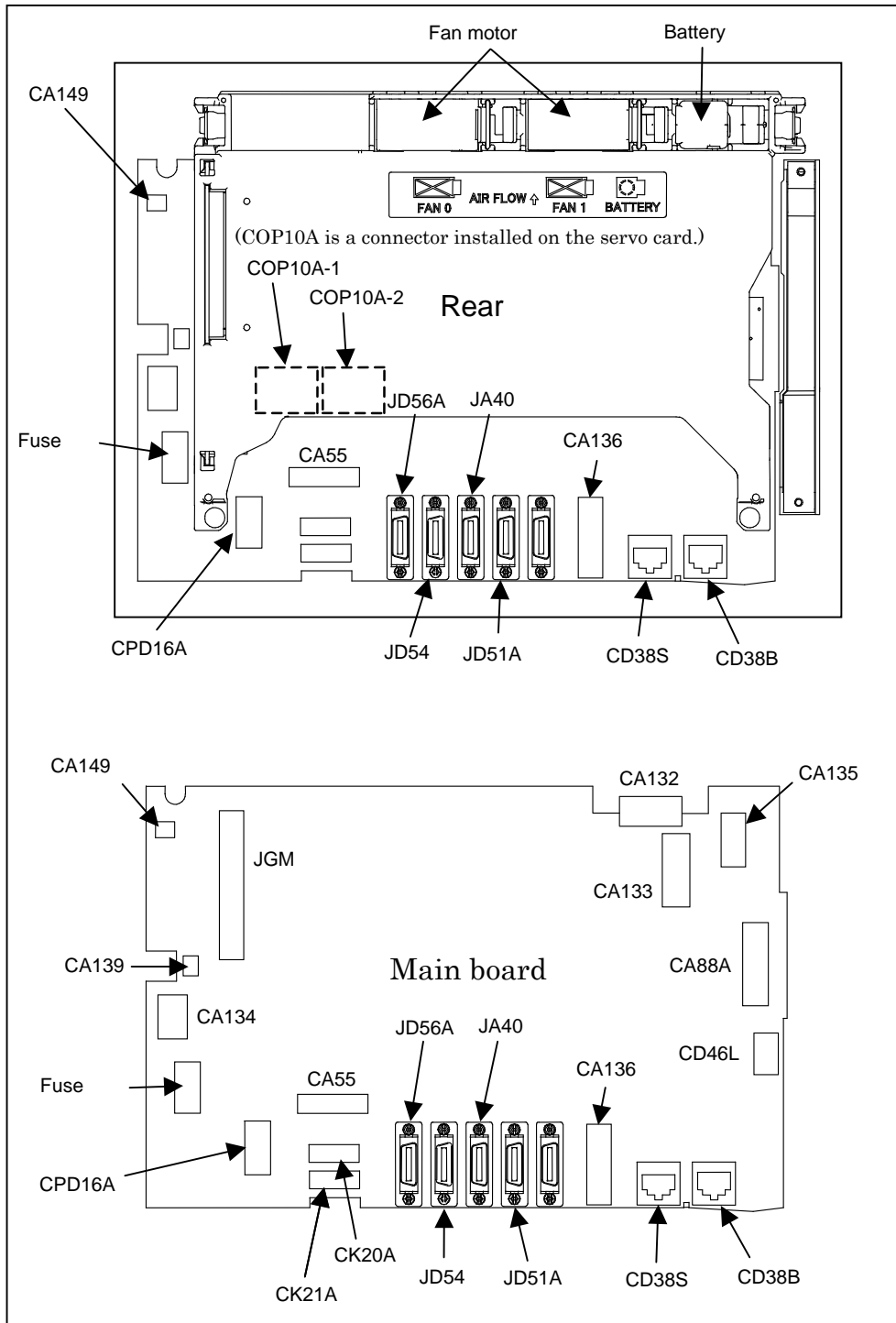

				Title Series30i/31i/32i-MODEL B The correction of maintenance manual
				DRAW. NO. B-64485EN/01-02 CUST
EDIT	DATE	DESIG.	DESCRIPTION	<b>FANUC CORPORATION</b> SHEET 5 / 9

Connector number	Application
COP10A-1, COP10A-2	For FSSB interface
CA55	For MDI
JD56A	For I/O device interface (RS-232C)
JD54	For I/O device interface (RS-232C) or USB device
JA40	For high-speed skip
JD51A	For I/O Link i and I/O Link
CPD16A	For power supply
JGM	For back panel
CA133	For video signal interface (for 10.4"/12.1"LCD)
CA135	For video signal interface (for 15"LCD)
CA88A	For memory card interface
CD46L	For USB port
CK20A	For horizontal soft key
CK21A	For vertical soft key
CA132	For inverter board (for 10.4"LCD) For fan adapter board (for 12.1"/15" LCD)
CD38S	For Ethernet (Windows CE control or Embedded Ethernet)
CD38B	Ethernet (Multi-function Ethernet)
CA139	For touch panel interface
CA134	For inverter board (for 12.1"/15" LCD)
CA149	For buzzer interface
CA136	For backup unit

				Title Series30i/31i/32i-MODEL B The correction of maintenance manual
				DRAW. NO. B-64485EN/01-02 CUST
EDIT	DATE	DESIG.	DESCRIPTION	<b>FANUC CORPORATION</b> SHEET 6 / 9

Section 2.5.3 The name of connector for buzzer was corrected.

## 2.5.3 Display Unit for Stand-Alone Type Control Unit (with Personal Computer Function with Windows<sup>®</sup> CE)

- Connector mounting location

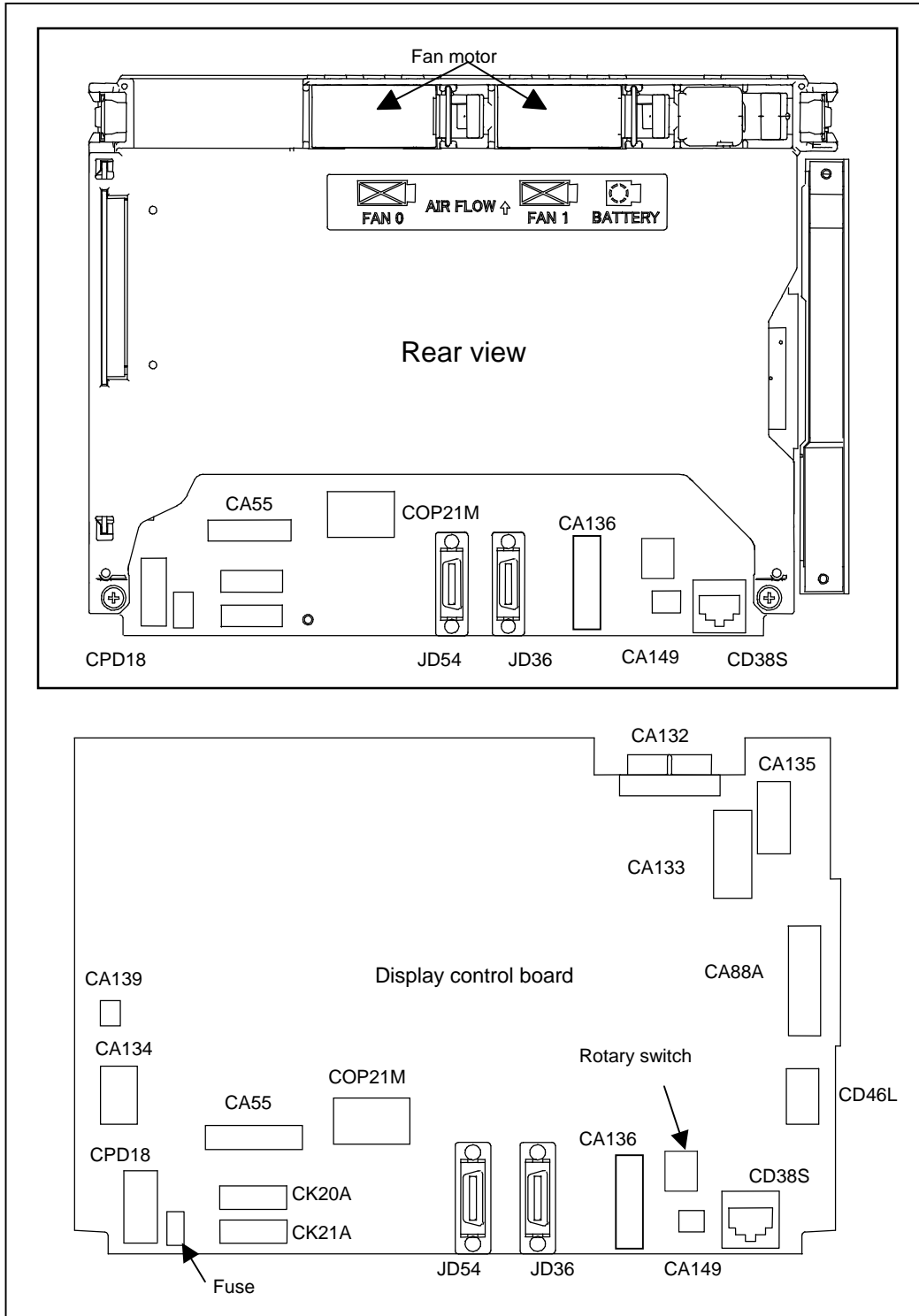

				Title Series30i/31i/32i-MODEL B The correction of maintenance manual
				DRAW. NO. B-64485EN/01-02 CUST
EDIT	DATE	DESIG.	DESCRIPTION	<b>FANUC CORPORATION</b> SHEET 7 / 9

Connector number	Application
CA55	For MDI
JD36	For I/O device interface (RS-232C)
JD54	For I/O device interface (RS-232C) or USB device
CPD18	For power supply
CA133	For video signal interface (for 10.4"/12.1" display unit)
CA135	For video signal interface (for 15" display unit)
CA88A	For memory card interface
CD46L	For USB port
CK20A	For horizontal soft key
CK21A	For vertical soft key
CA132	For inverter board (for 10.4" display unit) For fan adapter board (for 12.1"/15" display unit)
COP21M	For HSSB interface
CD38S	For Ethernet (Windows CE control)
CA139	For touch panel interface
CA134	For inverter board (for 12.1"/15" display unit)
CA149	For buzzer interface
CA136	For backup unit

				Title Series30i/31i/32i-MODEL B The correction of maintenance manual
				DRAW. NO. B-64485EN/01-02 CUST
EDIT	DATE	DESIG.	DESCRIPTION	<b>FANUC CORPORATION</b> SHEET 8 / 9

### 3.7 ATTACHING A COMPACT FLASH CARD ONTO, AND DETACHING IT FROM, A PRINTED CIRCUIT BOARD

**⚠ CAUTION**  
 Before starting to replace the compact flash card, make a backup copy of the contents (parameters, programs, etc.) of SRAM in the CNC. The SRAM contents may be lost during replacement. See Chapter 5, "INPUT AND OUTPUT OF DATA", and Appendix C, "BOOT SYSTEM" for explanations about how to make backup copies. Also see Subsection 3.1.1, "Optional Information File".

Some types of printed circuit boards incorporate a compact flash card. When replacing these printed circuit boards, stick to the following procedures.

#### Dismounting procedure

Pull out the stopper up. Turn the latch inward and pull out the card.

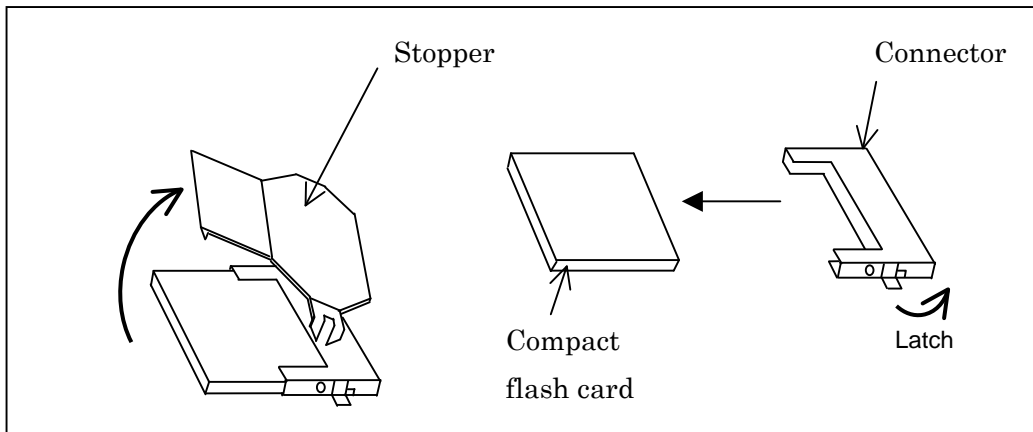

#### Mounting procedure

Insert the card in the connector, and put up the stopper.

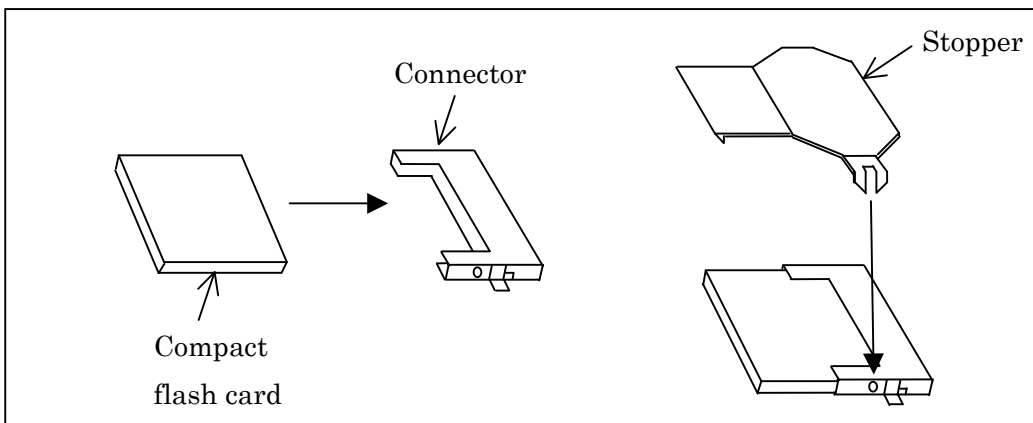

				Title Series30i/31i/32i-MODEL B The correction of maintenance manual
				DRAW. NO. B-64485EN/01-02 CUST
EDIT	DATE	DESIG.	DESCRIPTION	<b>FANUC CORPORATION</b> SHEET 9 / 9

Addition in FANUC Series 30i-B / 31i-B / 32i-B MAINTENANCE MANUAL

1. Type of applied technical documents

Name	FANUC Series 30i-MODEL B FANUC Series 31i-MODEL B FANUC Series 32i-MODEL B MAINTENANCE MANUAL
Spec.No. / Version	B-64485EN/01

2. Summary of change

Group	Name / Outline	New, Add, Correct, Delete	Applicable Date
Basic Function	Explanation of the alarms PS5523 and PS5524 has been added.	Add	Immediately
Optional Function			
Unit			
Maintenance parts			
Notice	Notes for FROM/SRAM module replacement have also been added.	Add	Immediately
Correction			
Another			

				Addition in FANUC Series 30i-B / 31i-B / 32i-B MAINTENANCE MANUAL	
01	11.11.18	Kobayashi	New issue	DRAW. NO. B-64485EN/01-03	CUST.
Edit.	DATE	Design	Description	<b>FANUC CORPORATION</b>	SHEET 1 / 5

We add the specification of FROM/SRAM module in the P.C.B. list at the following paragraph.

- 2.4.1 LCD-mounted Type Control Unit (8.4" LCD Unit and 10.4" LCD Unit A)
- 2.4.2 LCD-mounted Type Control Unit (10.4" LCD Unit B and 15" LCD Unit)
- 2.4.3 LCD-mounted Type Control Unit (with Personal Computer Function with Windows®CE) Hardware
- 2.5.1 Stand-alone Type Control Unit
- 3.1 CAUTIONS FOR REPLACEMENT
- 3.6 MOUNTING AND DEMOUNTING FROM/SRAM MODULE
- B.3 PRINTED CIRCUIT BOARDS COMMON TO LCD-MOUNTED AND STAND-ALONE TYPE CONTROL UNITS

## 2.4.1 LCD-mounted Type Control Unit (8.4" LCD Unit and 10.4" LCD Unit A)

(P.173)

No.	Name	Specification	Remark
(4)	FROM/SRAM module	A20B-3900-0250	The FROM stores various control software programs, user software programs, and so forth. The SRAM is a battery-backed memory module.
		A20B-3900-0251	
		A20B-3900-0252	When a FROM/SRAM module is replaced, the FANUC service division installs system software.

## 2.4.2 LCD-mounted Type Control Unit (10.4" LCD Unit B and 15" LCD Unit)

(P.182)

No.	Name	Specification	Remark
(1)	FROM/SRAM module	A20B-3900-0260	The FROM stores various control software programs, user software programs, and so forth. The SRAM is a battery-backed memory module. When a FROM/SRAM module is replaced, the FANUC service division installs system software.

				Addition in FANUC Series 30i-B / 31i-B / 32i-B MAINTENANCE MANUAL	
				DRAW. NO. B-64485EN/01-03	CUST.
Edit.	DATE	Design	Description	<b>FANUC CORPORATION</b>	SHEET 2 / 5

## 2.4.3 LCD-mounted Type Control Unit (with Personal Computer Function with Windows®CE) Hardware

(P.191)

No.	Name	Specification	Remark
(1)	FROM/SRAM module	A20B-3900-0260	The FROM stores various control software programs, user software programs, and so forth. The SRAM is a battery-backed memory module. When a FROM/SRAM module is replaced, the FANUC service division installs system software.

## 2.5.1 Stand-alone Type Control Unit

(P.200)

No.	Name	Specification	Remark
(3)	FROM/SRAM module	A20B-3900-0250	FROM stores various control software products.
		A20B-3900-0251	The SRAM is a battery-backed memory module.
		A20B-3900-0252	When a FROM/SRAM module is replaced, the
		A20B-3900-0260	FANUC service division installs system software.

## 3.1 CAUTIONS FOR REPLACEMENT

(P.250)

### NOTE

- 1 When a FROM/SRAM module is replaced, the FANUC service division installs system software.
- 2 The LCD (liquid-crystal display) has been fabricated using an extreme precision technology. However, some of their pixels may fail to light or stay constantly lighting because of their characteristics. Please be forewarned that these phenomena are not faults.

				Addition in FANUC Series 30i-B / 31i-B / 32i-B MAINTENANCE MANUAL	
				DRAW. NO. B-64485EN/01-03	CUST.
Edit.	DATE	Design	Description	<b>FANUC CORPORATION</b>	SHEET 3 / 5



### 3.6 MOUNTING AND DEMOUNTING FROM/SRAM MODULE

(P.261)

**NOTE**

When a FROM/SRAM module is replaced, the FANUC service division installs system software.

### B.3 PRINTED CIRCUIT BOARDS COMMON TO LCD-MOUNTED AND STAND-ALONE TYPE CONTROL UNITS

(P.735,736)

Item	Specification	ID	Remark
FROM/SRAM module O	A02B-3900-0250	FROM: D4, SRAM: 03	*
FROM/SRAM module P	A02B-3900-0251	FROM: D4, SRAM: 04	*
FROM/SRAM module M	A02B-3900-0252	FROM: D3, SRAM: 03	*
FROM/SRAM module R	A20B-3900-0260	FROM: D4, SRAM: 06	* For personal computer function with Windows® CE

\* When a FROM/SRAM module is replaced, the FANUC service division installs system software.

				Addition in FANUC Series 30i-B / 31i-B / 32i-B MAINTENANCE MANUAL	
				DRAW. NO. B-64485EN/01-03	CUST.
Edit.	DATE	Design	Description	<b>FANUC CORPORATION</b>	SHEET 4 / 5

Add the following description to the table of the PS/BG/SR alarm in the appendix A.1 ALARM LIST (CNC)

## A.1 ALARM LIST(CNC)

(P.663)

Number	Message	Description
5523	WAITING THE OPTION CERTIFICATION	<p>CNC is under the option certification waiting state.</p> <ul style="list-style-type: none"> <li>• This alarm can be cleared by the reset operation before the expiration date (30 days after generating the alarm).</li> <li>• As for the certification operation to clear this alarm permanently, please contact the FANUC service division by the above date.</li> <li>• When the certification operation is not executed by the expiration date, the alarm PS5524 occurs. This alarm cannot be cleared by the reset operation.</li> </ul>
5524	OPTION CERTIFICATION (EXPIRE)	<p>The option certification waiting state was expired.</p> <ul style="list-style-type: none"> <li>• This alarm cannot be cleared by the reset operation.</li> <li>• As for the certification operation to clear this alarm permanently, please contact the FANUC service division.</li> </ul>

				Addition in FANUC Series 30i-B / 31i-B / 32i-B MAINTENANCE MANUAL	
				DRAW. NO. B-64485EN/01-03	CUST.
Edit.	DATE	Design	Description	<b>FANUC CORPORATION</b>	SHEET 5 / 5